

2004 - 2013



SERVICE MANUAL

**CRF80F**

**CRF100F**

## A Few Words About Safety

### Service Information

The service and repair information contained in this manual is intended for use by qualified, professional technicians. Attempting service or repairs without the proper training, tools, and equipment could cause injury to you or others. It could also damage the vehicle or create an unsafe condition.

This manual describes the proper methods and procedures for performing service, maintenance, and repairs. Some procedures require the use of specially designed tools and dedicated equipment. Any person who intends to use a replacement part, service procedure or a tool that is not recommended by Honda, must determine the risks to their personal safety and the safe operation of the vehicle.

If you need to replace a part, use genuine Honda parts with the correct part number or an equivalent part. We strongly recommend that you do not use replacement parts of inferior quality.

### For Your Customer's Safety

Proper service and maintenance are essential to the customer's safety and the reliability of the vehicle. Any error or oversight while servicing a vehicle can result in faulty operation, damage to the vehicle, or injury to others.

### For Your Safety

Because this manual is intended for the professional service technician, we do not provide warnings about many basic shop safety practices (e.g., Hot parts—wear gloves). If you have not received shop safety training or do not feel confident about your knowledge of safe servicing practice, we recommend that you do not attempt to perform the procedures described in this manual.

Some of the most important general service safety precautions are given below. However, we cannot warn you of every conceivable hazard that can arise in performing service and repair procedures. Only you can decide whether or not you should perform a given task.

### Important Safety Precautions

Make sure you have a clear understanding of all basic shop safety practices and that you are wearing appropriate clothing and using safety equipment. When performing any service task, be especially careful of the following:

- Read all of the instructions before you begin, and make sure you have the tools, the replacement or repair parts, and the skills required to perform the tasks safely and completely.
- Protect your eyes by using proper safety glasses, goggles or face shields any time you hammer, drill, grind, pry or work around pressurized air or liquids, and springs or other stored-energy components. If there is any doubt, put on eye protection.
- Use other protective wear when necessary, for example gloves or safety shoes. Handling hot or sharp parts can cause severe burns or cuts. Before you grab something that looks like it can hurt you, stop and put on gloves.
- Protect yourself and others whenever you have the vehicle up in the air. Any time you lift the vehicle, either with a hoist or a jack, make sure that it is always securely supported. Use jack stands.

Make sure the engine is off before you begin any servicing procedures, unless the instruction tells you to do otherwise. This will help eliminate several potential hazards:

- Carbon monoxide poisoning from engine exhaust. Be sure there is adequate ventilation whenever you run the engine.
- Burns from hot parts or coolant. Let the engine and exhaust system cool before working in those areas.
- Injury from moving parts. If the instruction tells you to run the engine, be sure your hands, fingers and clothing are out of the way.

Gasoline vapors and hydrogen gases from batteries are explosive. To reduce the possibility of a fire or explosion, be careful when working around gasoline or batteries.

- Use only a nonflammable solvent, not gasoline, to clean parts.
- Never drain or store gasoline in an open container.
- Keep all cigarettes, sparks and flames away from the battery and all fuel-related parts.

#### ⚠ WARNING

Improper service or repairs can create an unsafe condition that can cause your customer or others to be seriously hurt or killed.

Follow the procedures and precautions in this manual and other service materials carefully.

#### ⚠ WARNING

Failure to properly follow instructions and precautions can cause you to be seriously hurt or killed.

Follow the procedures and precautions in this manual carefully.



# HOW TO USE THIS MANUAL

This service manual describes the service procedures for the CRF80F and CRF100F.

Follow the Maintenance Schedule (Section 3) recommendations to ensure that the vehicle is in peak operating condition and the emission levels are within the standard set by the U.S. Environmental Protection Agency (EPA) and California Air Resources Board (CARB).

Performing the first scheduled maintenance is very important. It compensates for the initial wear that occurs during the break-in period.

Sections 1 and 3 apply to the whole motorcycle. Section 2 illustrates procedures for removal/installation of components that may be required to perform service described in the following sections.

Section 4 through 14 describe parts of the motorcycle, grouped according to location.

Find the section you want on this page, then turn to the table of contents on the first page of the section.

Most sections start with an assembly or system illustration, service information and troubleshooting for the section. The subsequent pages give detailed procedures.

If you don't know the source of the trouble, go to Section 16 Troubleshooting.

Your safety, and the safety of others, is very important. To help you make informed decisions we have provided safety messages and other information throughout this manual. Of course, it is not practical or possible to warn you about all the hazards associated with servicing this vehicle.

You must use your own good judgement.

You will find important safety information in a variety of forms including:

- Safety Labels – on the vehicle
- Safety Messages – preceded by a safety alert symbol  and one of three signal words, DANGER, WARNING, or CAUTION. These signal words mean:

**▲ DANGER** You WILL be KILLED or SERIOUSLY HURT if you don't follow instructions.

**▲ WARNING** You CAN be KILLED or SERIOUSLY HURT if you don't follow instructions.

**▲ CAUTION** You CAN be HURT if you don't follow instructions.

- Instructions – how to service this vehicle correctly and safely.











As you read this manual, you will find information that is preceded by a **NOTICE** symbol. The purpose of this message is to help prevent damage to your vehicle, other property, or the environment.

# CONTENTS

	<b>GENERAL INFORMATION</b>	<b>1</b>
	<b>FRAME/BODY PANELS/EXHAUST SYSTEM</b>	<b>2</b>
	<b>MAINTENANCE</b>	<b>3</b>
<b>ENGINE AND DRIVE TRAIN</b>	<b>LUBRICATION SYSTEM</b>	<b>4</b>
	<b>FUEL SYSTEM</b>	<b>5</b>
	<b>ENGINE REMOVAL/INSTALLATION</b>	<b>6</b>
	<b>CYLINDER HEAD/VALVES</b>	<b>7</b>
	<b>CYLINDER/PISTON</b>	<b>8</b>
	<b>CLUTCH/GEARSHIFT LINKAGE</b>	<b>9</b>
	<b>ALTERNATOR</b>	<b>10</b>
	<b>CRANKSHAFT/TRANSMISSION/KICKSTARTER</b>	<b>11</b>
	<b>CHASSIS</b>	<b>FRONT WHEEL/BRAKE/SUSPENSION/STEERING</b>
<b>REAR WHEEL/BRAKE/SUSPENSION</b>		<b>13</b>
<b>ELECTRICAL</b>	<b>ELECTRICAL SYSTEM</b>	<b>14</b>
	<b>WIRING DIAGRAM</b>	<b>15</b>
	<b>TROUBLESHOOTING</b>	<b>16</b>
	<b>INDEX</b>	<b>17</b>

# SYMBOLS

The symbols used throughout this manual show specific service procedures. If supplementary information is required pertaining to these symbols, it will be explained specifically in the text without the use of the symbols.

	<p>Replace the part(s) with new one(s) before assembly.</p>
	<p>Use recommended engine oil, unless otherwise specified.</p>
	<p>Use molybdenum oil solution (mixture of the engine oil and molybdenum grease in a ratio of 1: 1).</p>
	<p>Use multi-purpose grease (Lithium based multi-purpose grease NLGI #2 or equivalent).</p>
	<p>Use molybdenum disulfide grease (containing more than 3% molybdenum disulfide, NLGI #2 or equivalent).            Example: Molykote® BR-2 plus manufactured by Dow Corning U.S.A.            Multi-purpose M-2 manufactured by Mitsubishi Oil, Japan</p>
	<p>Use molybdenum disulfide paste (containing more than 40% molybdenum disulfide, NLGI #2 or equivalent).            Example: Molykote® G-n Paste manufactured by Dow Corning U.S.A.            Honda Moly 60 (U.S.A. only)            Rocol ASP manufactured by Rocol Limited, U.K.            Rocol Paste manufactured by Sumico Lubricant, Japan</p>
	<p>Use silicone grease.</p>
	<p>Apply a locking agent. Use a middle strength locking agent unless otherwise specified.</p>
	<p>Apply sealant.</p>
	<p>Use DOT 4 brake fluid. Use the recommended brake fluid unless otherwise specified.</p>
	<p>Use Fork or Suspension Fluid.</p>



# 1. GENERAL INFORMATION

---

SERVICE RULES .....	1-2	CRANKSHAFT/TRANSMISSION/ KICKSTARTER SPECIFICATIONS (CRF100F).....	1-10
MODEL IDENTIFICATION.....	1-2	CRANKSHAFT/TRANSMISSION/ KICKSTARTER SPECIFICATIONS (CRF80F).....	1-11
GENERAL SPECIFICATIONS.....	1-5	FRONT WHEEL/BRAKE/SUSPENSION/ STEERING SPECIFICATIONS .....	1-11
LUBRICATION SYSTEM SPECIFICATIONS.....	1-7	REAR WHEEL/BRAKE/SUSPENSION SPECIFICATIONS .....	1-12
FUEL SYSTEM SPECIFICATIONS (CRF100F).....	1-7	ELECTRICAL SYSTEM SPECIFICATIONS .....	1-12
FUEL SYSTEM SPECIFICATIONS (CRF80F).....	1-7	STANDARD TORQUE VALUES.....	1-13
CYLINDER HEAD/VALVES SPECIFICATIONS.....	1-8	ENGINE & FRAME TORQUE VALUES....	1-13
CYLINDER/PISTON SPECIFICATIONS (CRF100F).....	1-9	LUBRICATION & SEAL POINTS .....	1-15
CYLINDER/PISTON SPECIFICATIONS (CRF80F).....	1-9	CABLE & HARNESS ROUTING .....	1-17
CLUTCH/GEARSHIFT LINKAGE SPECIFICATIONS.....	1-10	EMISSION CONTROL SYSTEMS.....	1-21

## GENERAL INFORMATION

---

### SERVICE RULES

1. Use genuine Honda or Honda-recommended parts and lubricants or their equivalents. Parts that don't meet Honda's design specifications may cause damage to the motorcycle.
2. Use the special tools designed for this product to avoid damage and incorrect assembly.
3. Use only metric tools when servicing the motorcycle. Metric bolts, nuts and screws are not interchangeable with English fasteners.
4. Install new gaskets, O-rings, cotter pins, and lock plates when reassembling.
5. When tightening bolts or nuts, begin with the larger diameter or inner bolt first. Then tighten to the specified torque diagonally in incremental steps unless a particular sequence is specified.
6. Clean parts in cleaning solvent upon disassembly. Lubricate any sliding surfaces before reassembly.
7. After reassembly, check all parts for proper installation and operation.
8. Route all electrical wires as shown in the Cable and Harness Routing (page 1-17).

### MODEL IDENTIFICATION

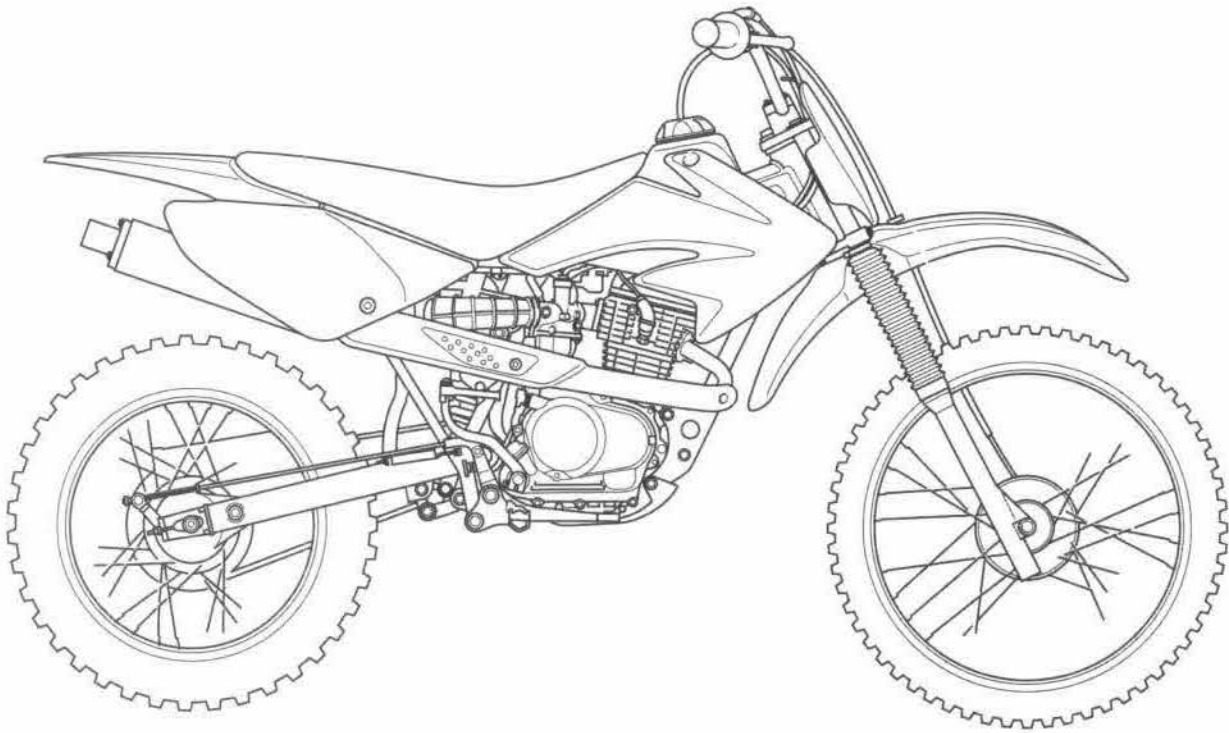

## GENERAL INFORMATION

The Vehicle Identification Number is stamped on the left side of the steering head.



The engine serial number is stamped on the lower left side of the lower crankcase.



The Model Identification Label (U.S.A.) or Safety Certification Label (Canada) is located on right side of the steering head.

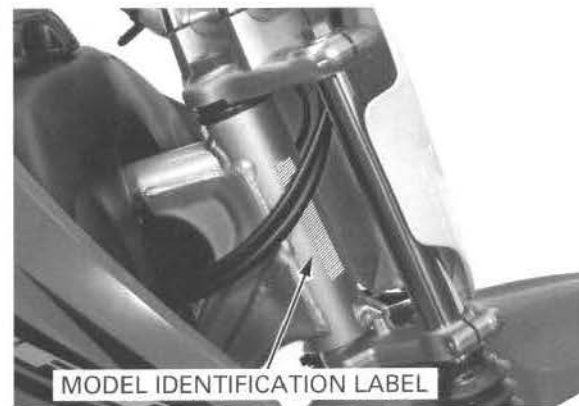

The carburetor identification number is stamped on the right side of the carburetor body as shown.





## GENERAL INFORMATION

The Emission Control Information Label is attached as shown.

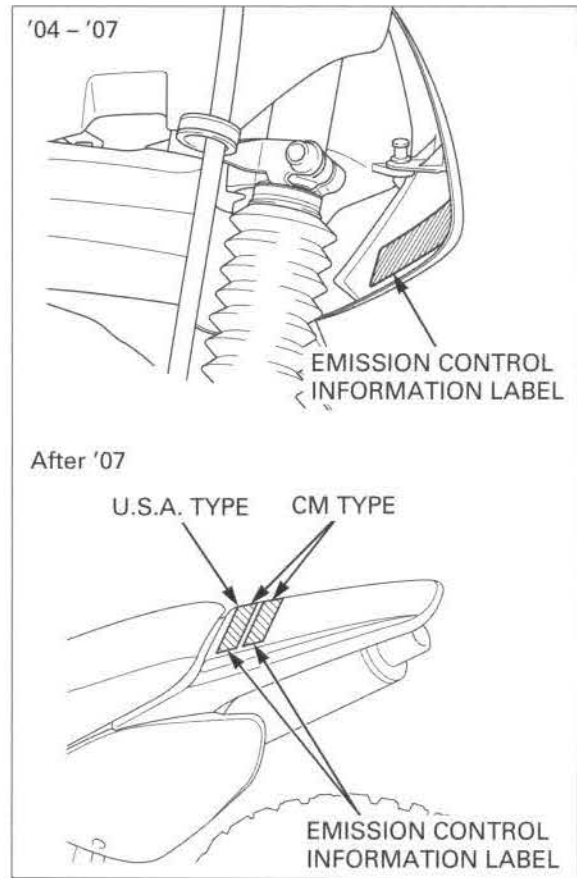

The color label is attached as shown. When ordering color-coded parts, always specify the designated color code.



## GENERAL SPECIFICATIONS

## CRF80F

ITEM		SPECIFICATION
DIMENSIONS	Overall length	1,749 mm (68.9 in)
	Overall width	727 mm (28.6 in)
	Overall height	995 mm (39.2 in)
	Wheelbase	1,209 mm (47.6 in)
	Seat height	734 mm (28.9 in)
	Footpeg height	271 mm (10.7 in)
	Ground clearance	218 mm (8.6 in)
	Curb weight	75 kg (165 lbs)
FRAME	Frame type	Back bone
	Front suspension	Telescopic fork
	Front wheel travel	123 mm (5.02 in)
	Rear suspension	Swingarm
	Rear wheel travel	110.0 mm (4.33 in)
	Rear damper	Conventional type oil damper
	Front tire size	2.50-16 4PR
	Rear tire size	3.60-14 4PR
	Tire brand	IRC
	Front brake	Internal expanding shoe
	Rear brake	Internal expanding shoe
	Caster angle	28°02'
	Trail length	74 mm (2.9 in)
	Fuel tank capacity	5.5 liter (1.45 US gal, 1.21 Imp gal)
	(After '07)	5.0 liter (1.32 US gal, 1.10 Imp gal)
	Fuel tank reserve capacity	1.1 liter (0.29 US gal, 0.24 Imp gal)
	(After '07)	0.7 liter (0.18 US gal, 0.15 Imp gal)
ENGINE	Bore and stroke	47.5 x 45.0 mm (1.87 x 1.77 in)
	Displacement	79.7 cm <sup>3</sup> (4.86 cu-in)
	Compression ratio	9.7 : 1
	Valve train	Chain drive and OHC with rocker arm
	Intake valve	opens at 1 mm (0.04 in) lift
		closes at 1 mm (0.04 in) lift
	Exhaust valve	opens at 1 mm (0.04 in) lift
		closes at 1 mm (0.04 in) lift
	Lubrication system	Forced pressure and wet sump
	Oil pump type	Trochoid
	Cooling system	Air cooled
	Air filtration	Oiled polyurethane foam
Crankshaft type	Assembled type	
Engine dry weight	18.9 kg (41.7 lbs)	
Cylinder arrangement	Single cylinder inclined 15° from vertical	
CARBURETOR	Carburetor type	Piston valve type
	Throttle bore	18 mm (0.71 in)
DRIVE TRAIN	Clutch system	Multi-plate, wet
	Clutch operation system	Mechanical type
	Transmission	5 speeds
	Primary reduction	4.437 (71/16)
	Final reduction	3.285 (46/14)
	Gear ratio	1st 2.692 (35/13)
		2nd 1.823 (31/17)
		3rd 1.400 (28/20)
	4th 1.130 (26/23)	
	5th 0.960 (24/25)	
	Gearshift pattern	Left foot operated return system, 1 - N - 2 - 3 - 4 - 5
ELECTRICAL	Ignition system	Capacitive Discharged Ignition
	Starting system	Kickstarter

## GENERAL INFORMATION

### CRF100F

	ITEM	SPECIFICATION	
DIMENSIONS	Overall length	1,853 mm (73.0 in)	
	Overall width	786 mm (30.9 in)	
	Overall height	1,046 mm (4.12 in)	
	Wheelbase	1,249 mm (49.2 in)	
	Seat height	786 mm (30.9 in)	
	Footpeg height	319 mm (12.6 in)	
	Ground clearance	252 mm (9.9 in)	
	Curb weight	('04 - '07) (After '07)	79 kg (174 lbs) 77 kg (170 lbs)
FRAME	Frame type	Back bone	
	Front suspension	Telescopic fork	
	Front wheel travel	132 mm (5.2 in)	
	Rear suspension	Swingarm	
	Rear wheel travel	148.0 mm (5.83 in)	
	Rear damper	Conventional type oil damper	
	Front tire size	70/100-19 M/C 42M	
	Rear tire size	90/100-16 M/C 51M	
	Tire brand	Cheng shin	
	Front brake	Internal expanding shoe	
	Rear brake	Internal expanding shoe	
	Caster angle	28°50'	
	Trail length	99 mm (3.9 in)	
	Fuel tank capacity	('04 - '07) (After '07)	5.5 liter (1.45 US gal, 1.21 Imp gal) 5.0 liter (1.32 US gal, 1.10 Imp gal)
Fuel tank reserve capacity	('04 - '07) (After '07)	1.1 liter (0.29 US gal, 0.24 Imp gal) 0.7 liter (0.18 US gal, 0.15 Imp gal)	
ENGINE	Bore and stroke	53.0 x 45.0 mm (2.09 x 1.77 in)	
	Displacement	99.2 cm <sup>3</sup> (6.1 cu-in)	
	Compression ratio	9.4 : 1	
	Valve train	Silent, multi-link chain drive and OHC with rocker arm	
	Intake valve	opens at 1 mm (0.04 in) lift closes at 1 mm (0.04 in) lift	10° BTDC 35° ABDC
	Exhaust valve	opens at 1 mm (0.04 in) lift closes at 1 mm (0.04 in) lift	40° BBDC 5° ATDC
	Lubrication system	Forced pressure and wet sump	
	Oil pump type	Trochoid	
	Cooling system	Air cooled	
	Air filtration	Oiled polyurethane foam	
Crankshaft type	Assembled type		
Engine dry weight	21.4 kg (47.18 lbs)		
Cylinder arrangement	Single cylinder inclined 15° from vertical		
CARBURETOR	Carburetor type	Piston valve type	
	Throttle bore	20 mm (0.8 in)	
DRIVE TRAIN	Clutch system	Multi-plate, wet	
	Clutch operation system	Mechanical type	
	Transmission	5 speeds	
	Primary reduction	4.437 (71/16)	
	Final reduction	3.571 (50/14)	
	Gear ratio	1st 2nd 3rd 4th 5th	3.083 (37/12) 1.882 (32/17) 1.400 (28/20) 1.130 (26/23) 0.923 (24/26)
	Gearshift pattern	Left foot operated return system, 1 - N - 2 - 3 - 4 - 5	
ELECTRICAL	Ignition system	Condenser Discharged Ignition	
	Starting system	Kickstarter	



## LUBRICATION SYSTEM SPECIFICATIONS

Unit: mm (in)

ITEM		STANDARD	SERVICE LIMIT
Engine oil capacity	CRF100F	At draining	0.9 liter (1.0 US qt, 0.8 Imp qt)
		At disassembly	1.1 liter (1.2 US qt, 1.0 Imp qt)
	CRF80F	At draining	0.9 liter (1.0 US qt, 0.8 Imp qt)
		At disassembly	1.1 liter (1.2 US qt, 1.0 Imp qt)
Recommended engine oil		Pro Honda GN4 4-stroke oil (U.S.A and Canada) or equivalent motor oil API service classification: SG or higher JASO T 903 standard: MA Viscosity: SAE 10W-30	-
Oil pump rotor	Tip clearance	0.15 (0.006)	0.20 (0.008)
	Body clearance	0.15 - 0.21 (0.006 - 0.008)	0.40 (0.016)
	Side clearance	0.02 - 0.07 (0.001 - 0.003)	0.25 (0.010)

## FUEL SYSTEM SPECIFICATIONS (CRF100F)

ITEM	SPECIFICATIONS
Carburetor identification number ('04 and '05)	PDC3L
Carburetor identification number ('06 and '07)	PDCBF
Carburetor identification number (After '07)	PDCBL
Carburetor type	Piston valve
Main jet	#98
Main jet (High altitude setting)	#92
Slow jet	#35 x #35
Jet needle clip position ('04 and '05)	3rd groove from top
Pilot screw opening	See page 5-18
Float level	12.5 mm (0.49 in)
Engine idle speed	1,400 ± 100 rpm
Throttle grip free play	2 - 6 mm (1/12 - 1/4 in)

## FUEL SYSTEM SPECIFICATIONS (CRF80F)

ITEM	SPECIFICATIONS
Carburetor identification number ('04 and '05)	PC20M
Carburetor identification number ('06 and '07)	PC20P
Carburetor identification number (After '07)	PC20Q
Carburetor type	Piston valve
Main jet	#95
Main jet (High altitude setting)	#90
Slow jet	#35
Jet needle clip position ('04 and '05)	3rd groove from top
Air screw opening	See page 5-19
Float level	21.5 mm (0.85 in)
Engine idle speed	1,500 ± 100 rpm
Throttle grip free play	2 - 6 mm (1/12 - 1/4 in)

**GENERAL INFORMATION**

**CYLINDER HEAD/VALVES SPECIFICATIONS**

Unit: mm (in)

ITEM			STANDARD	SERVICE LIMIT	
Cylinder compression	CRF100F		1,176 kPa (12.0 kgf/cm <sup>2</sup> , 171 psi) at 1,000 rpm	-	
	CRF80F		1,176 kPa (12.0 kgf/cm <sup>2</sup> , 171 psi) at 1,000 rpm	-	
Cylinder head warpage			-	0.10 (0.004)	
Valve and valve guide	Valve clearance	IN	0.05(0.002)	-	
		EX	0.05(0.002)	-	
	Valve stem O.D.	IN	5.450 - 5.465 (0.2145 - 0.2151)	5.420 (0.2134)	
		EX	5.430 - 5.445 (0.2137 - 0.2143)	5.400 (0.2126)	
	Valve guide I.D.	IN	5.475 - 5.485 (0.2155 - 0.2159)	5.50 (0.217)	
		EX	5.475 - 5.485 (0.2155 - 0.2159)	5.50 (0.217)	
	Stem to guide clearance	IN	0.010 - 0.035 (0.0004 - 0.0013)	0.08 (0.003)	
		EX	0.030 - 0.055 (0.0012 - 0.0022)	0.10 (0.004)	
Valve seat width	IN/EX	1.70(0.06)	2.1 (0.08)		
Valve spring free length	Inner	IN/EX	28.05 (1.104)	27.6 (1.09)	
	Outer	IN/EX	34.80 (1.370)	33.7 (1.33)	
Rocker arm/shaft	Rocker arm I.D.	IN/EX	10.000 - 10.015 (0.3937 - 0.3943)	10.1 (0.40)	
	Rocker arm shaft O.D.	IN/EX	9.978 - 9.987 (0.3928 - 0.3932)	9.91 (0.390)	
	Rocker arm to shaft clearance	IN/EX	0.013 - 0.037 (0.0005 - 0.0014)	0.08 (0.003)	
Camshaft	Cam lobe height	CRF100F	IN	27.860 - 28.040 (1.0968 - 1.1039)	27.80 (1.094)
			EX	27.776 - 27.950 (1.0935 - 1.1004)	27.70 (1.091)
		CRF80F	IN	28.007 - 28.207 (1.1026 - 1.1105)	27.95 (1.100)
			EX	27.825 - 28.025 (1.0955 - 1.1033)	27.75 (1.093)
	Journal O.D.	CRF100F	IN	19.950 - 19.968 (0.7854 - 0.7861)	19.90(0.783)
			EX	19.950 - 19.968 (0.7854 - 0.7861)	19.90(0.783)
		CRF80F	IN	19.950 - 19.968 (0.7854 - 0.7861)	19.90(0.783)
			EX	19.950 - 19.968 (0.7854 - 0.7861)	19.90(0.783)
Runout		-	0.03 (0.001)		
Camshaft holder I.D.	CRF100F		20.008 - 20.063 (0.7877 - 0.7899)	20.15(0.793)	
	CRF80F		20.008 - 20.063 (0.7877 - 0.7899)	20.15(0.793)	
Oil clearance	CRF100F		0.040 - 0.113 (0.0016 - 0.0044)	0.20(0.008)	
	CRF80F		0.040 - 0.113 (0.0016 - 0.0044)	0.20(0.008)	

## CYLINDER/PISTON SPECIFICATIONS (CRF100F)

Unit: mm (in)

ITEM		STANDARD	SERVICE LIMIT	
Cylinder	I.D.	53.000 – 53.010 (2.0866 – 2.0870)	53.1 (2.09)	
	Taper	–	0.10 (0.004)	
	Out of round	–	0.10 (0.004)	
	Warpage	–	0.10 (0.004)	
Piston, piston ring	Piston mark direction	"IN" mark facing toward the intake side	–	
	Piston O.D.	52.960 – 52.990 (2.0850 – 2.0862)	52.90 (2.083)	
	Piston O.D. measurement point	10 mm(0.4 in) from the bottom of skirt	–	
	Piston pin bore I.D.	14.002 – 14.008 (0.5513 – 0.5515)	14.04 (0.553)	
	Piston pin O.D.	13.994 – 14.000 (0.5509 – 0.5512)	13.96 (0.550)	
	Piston-to-piston pin clearance	0.002 – 0.014 (0.0001 – 0.0006)	0.020 (0.0008)	
	Piston ring to ring groove clearance	Top	0.015 – 0.045 (0.0006 – 0.0018)	0.10 (0.004)
		Second	0.015 – 0.045 (0.0006 – 0.0018)	0.10 (0.004)
	Piston ring end gap	Top ring	0.05 – 0.20 (0.002 – 0.008)	0.4 (0.02)
		Second ring	0.05 – 0.20 (0.002 – 0.008)	0.4 (0.02)
Oil ring (side rail)		0.20 – 0.70 (0.01 – 0.03)	0.9 (0.04)	
Cylinder-to-piston clearance		0.010 – 0.050 (0.0004 – 0.0020)	0.10 (0.004)	
Connecting rod small end I.D.		14.012 – 14.030 (0.5517 – 0.5523)	14.05 (0.553)	
Connecting rod-to-piston pin clearance		0.016 – 0.040 (0.0006 – 0.0016)	0.09 (0.003)	

## CYLINDER/PISTON SPECIFICATIONS (CRF80F)

Unit: mm (in)

ITEM		STANDARD	SERVICE LIMIT	
Cylinder	I.D.	47.500 – 47.510 (1.8701 – 1.8705)	47.6 (1.87)	
	Taper	–	0.10 (0.004)	
	Out of round	–	0.10 (0.004)	
	Warpage	–	0.10 (0.004)	
Piston, piston ring	Piston mark direction	"EX" mark facing toward the exhaust side	–	
	Piston O.D.	47.465 – 47.490 (1.8686 – 1.8697)	47.40 (1.866)	
	Piston O.D. measurement point	7 mm(0.3 in) from the bottom of skirt	–	
	Piston pin bore I.D.	13.002 – 13.008 (0.5119 – 0.5121)	13.04 (0.513)	
	Piston pin O.D.	12.994 – 13.000 (0.5116 – 0.5118)	12.96 (0.510)	
	Piston-to-piston pin clearance	0.002 – 0.014 (0.0001 – 0.0006)	0.020 (0.0008)	
	Piston ring to ring groove clearance	Top	0.015 – 0.045 (0.0006 – 0.0018)	0.10 (0.004)
		Second	0.015 – 0.045 (0.0006 – 0.0018)	0.10 (0.004)
	Piston ring end gap	Top ring	0.10 – 0.25 (0.004 – 0.010)	0.4 (0.02)
		Second ring	0.10 – 0.25 (0.004 – 0.010)	0.4 (0.02)
Oil ring (side rail)		0.20 – 0.70 (0.01 – 0.03)	0.9 (0.04)	
Cylinder-to-piston clearance		0.010 – 0.045 (0.0004 – 0.0018)	0.10 (0.004)	
Connecting rod small end I.D.		13.016 – 13.034 (0.5124 – 0.5131)	13.04 (0.513)	
Connecting rod-to-piston pin clearance		0.016 – 0.040 (0.0006 – 0.0016)	0.09 (0.003)	



## GENERAL INFORMATION

# CLUTCH/GEARSHIFT LINKAGE SPECIFICATIONS

Unit: mm (in)

ITEM		STANDARD	SERVICE LIMIT
Clutch lever free play		10 – 20 (3/8 – 3/4)	–
Clutch spring free length	CRF100F	31.9 (1.25)	29.5 (1.16)
	CRF80F	27.6 (1.09)	25.5 (1.00)
Clutch disc thickness	CRF100F	2.92 – 3.08 (0.115 – 0.121)	2.7 (0.11)
	CRF80F	2.90 – 3.00 (0.114 – 0.118)	2.5 (0.10)
Clutch plate warpage		–	0.20 (0.008)

# CRANKSHAFT/TRANSMISSION/KICKSTARTER SPECIFICATIONS (CRF100F)

Unit: mm (in)

ITEM			STANDARD	SERVICE LIMIT
Crankshaft	Runout	Right	0.035 (0.0014)	0.085 (0.0033)
		Left	0.020 (0.0008)	0.070 (0.0028)
	Connecting rod big end radial clearance		0 – 0.008 (0 – 0.0003)	0.010 (0.0004)
	Connecting rod big end side clearance		0.10 – 0.35 (0.0039 – 0.0138)	0.60 (0.024)
Transmission	Gear I.D.	M4, M5	17.016 – 17.034 (0.6699 – 0.6706)	17.05 (0.671)
		C1	20.662 – 20.643 (0.8135 – 0.8127)	20.66 (0.813)
		C2	19.520 – 19.541 (0.7685 – 0.7693)	19.56 (0.770)
		C3	18.016 – 18.034 (0.7093 – 0.7100)	18.05 (0.711)
	Bushing O.D.	C1	20.559 – 20.580 (0.8094 – 0.8102)	20.54 (0.809)
	Gear to bushing clearance (C1)		0.042 – 0.084 (0.0017 – 0.0033)	0.12 (0.005)
	Mainshaft O.D.	M4, M5	16.966 – 16.984 (0.6680 – 0.6687)	16.95 (0.667)
	Countershaft O.D.	C2	19.459 – 19.480 (0.7661 – 0.7669)	19.44 (0.765)
		C3	17.966 – 17.984 (0.7073 – 0.7080)	17.95 (0.707)
		Gear to shaft clearance	M4	0.032 – 0.068 (0.0013 – 0.0027)
C2	0.040 – 0.082 (0.0016 – 0.0032)		0.12 (0.005)	
C3	0.032 – 0.068 (0.0013 – 0.0027)		0.10 (0.004)	
Shift fork, shift fork shaft	Shift fork shaft O.D.		11.976 – 11.994 (0.4715 – 0.4722)	11.96 (0.471)
	Shift fork I.D.		12.000 – 12.018 (0.4724 – 0.4731)	12.05 (0.474)
	Shift fork claw thickness		4.93 – 5.00 (0.194 – 0.197)	4.70 (0.19)
Kickstarter	Spindle O.D.		17.959 – 17.980 (0.7070 – 0.7079)	17.88 (0.704)
	Pinion I.D.		18.020 – 18.041 (0.7094 – 0.7103)	18.06 (0.711)

## CRANKSHAFT/TRANSMISSION/KICKSTARTER SPECIFICATIONS (CRF80F)

Unit: mm (in)

ITEM		STANDARD	SERVICE LIMIT
Crankshaft	Runout	Right	0.035 (0.0014)
		Left	0.020 (0.0008)
	Connecting rod big end radial clearance		0 – 0.008 (0 – 0.0003)
	Connecting rod big end side clearance		0.10 – 0.35 (0.0039 – 0.0138)
Transmission	Gear I.D.	M4, M5	17.016 – 17.034 (0.6699 – 0.6706)
		C1	17.022 – 17.043 (0.6702 – 0.6710)
		C2	19.520 – 19.541 (0.7685 – 0.7693)
		C3	17.016 – 17.034 (0.6699 – 0.6706)
	Bushing O.D.	C1	20.559 – 20.580 (0.8094 – 0.8102)
	Gear to bushing clearance (C1)		0.042 – 0.084 (0.0017 – 0.0033)
	Mainshaft O.D.	M4, M5	16.966 – 16.984 (0.6680 – 0.6687)
	Countershaft O.D.	C2	19.459 – 19.480 (0.7661 – 0.7669)
		C3	16.966 – 16.984 (0.6680 – 0.6687)
	Gear to shaft clearance	M4	0.032 – 0.068 (0.0013 – 0.0027)
C2		0.040 – 0.082 (0.0016 – 0.0032)	
C3		0.032 – 0.068 (0.0013 – 0.0027)	
Shift fork, shift fork shaft	Shift fork shaft O.D.		11.976 – 11.994 (0.4715 – 0.4722)
	Shift fork I.D.		12.000 – 12.018 (0.4724 – 0.4731)
	Shift fork claw thickness		4.93 – 5.00 (0.194 – 0.197)
Kickstarter	Spindle O.D.		17.959 – 17.980 (0.7070 – 0.7079)
	Pinion I.D.		18.020 – 18.041 (0.7094 – 0.7103)

## FRONT WHEEL/BRAKE/SUSPENSION/STEERING SPECIFICATIONS

Unit: mm (in)

ITEM		STANDARD	SERVICE LIMIT
Front wheel	Cold tire pressure		100 kPa (1.00 kgf/cm <sup>2</sup> , 14 psi)
	Front wheel rim runout	Radial	–
		Axial	–
	Wheel hub-to-rim distance		12.0 ± 1.0
	Front axle runout		–
Brake	Lining thickness		4.0 (0.16)
	Drum I.D.		95.0 (3.74)
Fork	Spring free length	CRF100F	546.0 (21.50)
		CRF80F	531.2 (20.91)
	Fork pipe runout		–
	Recommended fork fluid		Pro Honda suspension Fluid SS-8 (10W)
	Fluid level	CRF100F	207.0 (8.15)
		CRF80F	177.0 (6.97)
Fluid capacity	CRF100F	84 ± 2.5 cm <sup>3</sup> (2.8 ± 0.08 US oz, 3.0 ± 0.09 Imp oz)	
	CRF80F	85 ± 2.5 cm <sup>3</sup> (2.9 ± 0.08 US oz, 3.0 ± 0.09 Imp oz)	

## GENERAL INFORMATION

# REAR WHEEL/BRAKE/SUSPENSION SPECIFICATIONS

Unit: mm (in)

ITEM			STANDARD	SERVICE LIMIT
Rear wheel	Cold tire pressure		100 kPa (1.00 kgf/cm <sup>2</sup> , 14 psi)	-
	Rear wheel rim runout	Radial	-	2.0 (0.08)
		Axial	-	2.0 (0.08)
	Wheel hub-to-rim distance		11.0 ± 1.0	-
Rear axle runout		-	0.20 (0.008)	
Drive chain	Slack		25 - 35 (1.0 - 1.4)	0.2 (0.01)
	Size/link	CRF100F    RK	RK428FDZ-118RJ	-
		CRF80F    RK	RK420MSZ1-110RJ	-
		DID	DID420MBK1-110RB	-
Brake	Lining thickness		4.0 (0.16)	2.0 (0.08)
	Drum I.D.		95.0 (3.74)	96.0 (3.78)
Shock absorber	Spring free length	CRF100F	123.5 (4.86)	121.0 (4.76)
		CRF80F	137.0 (5.39)	134.3 (5.29)
Shock linkage	Bushing I.D.		18.000 - 18.052 (0.7087 - 0.7107)	18.25 (0.719)
	Collar O.D.		17.941 - 17.968 (0.7063 - 0.7074)	17.91 (0.705)
Swingarm	Bushing I.D.		14.990 - 15.030 (0.5902 - 0.5917)	15.20 (0.598)
	Collar O.D.		14.966 - 14.984 (0.5892 - 0.5899)	14.94 (0.588)
Brake pedal	Pedal hole I.D.		17.300 - 17.327 (0.6811 - 0.6822)	15.20 (0.598)
	Collar O.D.		17.294 - 17.298 (0.6809 - 0.6810)	17.27 (0.680)

## ELECTRICAL SYSTEM SPECIFICATIONS

ITEM			SPECIFICATION
Spark plug	Standard	NGK	CR7HSA
		DENSO	U22FSR-U
	For cold climate/below (5°C/41°F)	NGK	CR6HSA
		DENSO	U20FSR-U
	For extended high speed riding	NGK	CR8HSA
		DENSO	U24FSR-U
Spark plug gap		0.6 - 0.7 (0.024 - 0.028)	
Ignition coil primary peak voltage			100 V minimum
Alternator exciter coil peak voltage			100 V minimum
Ignition pulse generator peak voltage			0.7 V minimum
Ignition timing ("F" mark)			15.5° BTDC / at 1,400 rpm

## STANDARD TORQUE VALUES

FASTENER TYPE	TORQUE N·m (kgf·m, lbf·ft)	FASTENER TYPE	TORQUE N·m (kgf·m, lbf·ft)
5 mm hex bolt and nut	5 (0.5, 3.6)	5 mm screw	4 (0.4, 2.9)
6 mm hex bolt and nut	10 (1.0, 7)	6 mm screw	9 (0.9, 6.5)
8 mm hex bolt and nut	22 (2.2, 16)	6 mm flange bolt (8 mm head)	9 (0.9, 6.5)
10 mm hex bolt and nut	34 (3.5, 25)	6 mm flange bolt (10 mm head) and nut	12 (1.2, 9)
12 mm hex bolt and nut	54 (5.5, 40)	8 mm flange bolt and nut	26 (2.7, 20)
		10 mm flange bolt and nut	39 (4.0, 29)

## ENGINE & FRAME TORQUE VALUES

- Torque specifications listed below are for specified fasteners.
- Others should be tightened to standard torque values listed above.

### NOTE:

1. U-nut
2. Apply a locking agent to the threads.
3. Apply grease to the sliding surface
4. Apply oil to the threads and seating surface.
5. Loosen the bolt 1/8 to 1/4 turns after tightening it to the specified torque, then tighten the pivot nut.

## ENGINE

### MAINTENANCE

ITEM	Q'TY	THREAD DIA. (mm)	TORQUE N·m (kgf·m, lbf·ft)	REMARKS
Spark plug	1	10	14 (1.4, 10)	
Oil drain bolt	1	12	24 (2.5, 18)	
Side stand pivot bolt	1	10	10 (1.0, 7)	NOTE 5
Side stand pivot nut	1	10	39 (4.0, 29)	
Valve adjusting screw lock nut	2	5	10 (1.0, 7)	NOTE 4
Cam chain tensioner adjusting bolt lock nut	1	8	12 (1.2, 9)	
Spoke	36	—	3 (0.3, 2)	
Rim rock	1	8	12 (1.2, 9)	

### LUBRICATION

ITEM	Q'TY	THREAD DIA. (mm)	TORQUE N·m (kgf·m, lbf·ft)	REMARKS
Oil pump plate screw	2	4	3 (0.3, 2)	

### FUEL SYSTEM

ITEM	Q'TY	THREAD DIA. (mm)	TORQUE N·m (kgf·m, lbf·ft)	REMARKS
Float chamber screw	3	4	2.1 (0.2, 1.4)	
Carburetor drain screw (CRF100F)	1	6	1.5 (0.15, 1.1)	
Carburetor drain screw (CRF80F)	1	6	2.5 (0.25, 1.8)	
Choke lever set plate screw (CRF100F only)	1	5	3.4 (0.35, 2.5)	

### CYLINDER HEAD/VALVES

ITEM	Q'TY	THREAD DIA. (mm)	TORQUE N·m (kgf·m, lbf·ft)	REMARKS
Cylinder head cover bolt	2	6	12 (1.2, 9)	
Camshaft holder nut	4	8	20 (2.0, 14)	
Cam sprocket bolt	2	6	12 (1.2, 9)	
Camchain tensioner adjusting bolt lock nut	1	8	12 (1.2, 9)	

### CLUTCH/GEARSHIFT LINKAGE

ITEM	Q'TY	THREAD DIA. (mm)	TORQUE N·m (kgf·m, lbf·ft)	REMARKS
Primary drive gear lock nut	1	14	39 (4.0, 29)	NOTE 4
Stopper arm pivot bolt	1	6	13 (1.3, 9)	
Shift return spring pin	1	8	30 (3.0, 22)	

## GENERAL INFORMATION

### ALTERNATOR

ITEM	Q'TY	THREAD DIA. (mm)	TORQUE N·m (kgf·m, lbf·ft)	REMARKS
Flywheel nut	1	10	64 (6.5, 47)	NOTE 1
Pulse generator mounting bolt	2	5	6 (0.6, 4.3)	NOTE 2

### FRAME

#### FRAME/BODY PANELS/EXHAUST SYSTEM

ITEM	Q'TY	THREAD DIA. (mm)	TORQUE N·m (kgf·m, lbf·ft)	REMARKS
Exhaust pipe/muffler mounting bolt	3	8	26 (2.7, 20)	
Exhaust pipe joint nut	2	6	12 (1.2, 9)	
Exhaust pipe protector bolt	2	6	14 (1.4, 10)	
Front fender bolt/nut	3	6	12 (1.2, 9)	
Fuel tank mounting bolt	2	6	12 (1.2, 9)	

#### ENGINE REMOVAL/INSTALLATION

ITEM	Q'TY	THREAD DIA. (mm)	TORQUE N·m (kgf·m, lbf·ft)	REMARKS
Gearshift pedal pinch bolt	1	6	10 (1.0, 7)	
Kickstarter pedal pinch bolt	1	6	12 (1.2, 9)	
Front engine hanger nut	2	8	34 (3.5, 25)	NOTE 1
Rear engine hanger nut	2	8	44 (4.5, 33)	NOTE 1
Engine hanger plate nut	2	8	34 (3.5, 25)	NOTE 1

#### FRONT WHEEL/BLAKE/SUSPENSION/STEERING

ITEM	Q'TY	THREAD DIA. (mm)	TORQUE N·m (kgf·m, lbf·ft)	REMARKS
Handlebar upper holder bolt	4	6	12 (1.2, 9)	
Front axle nut	1	12	62 (6.3, 46)	NOTE 1
Front brake arm pinch bolt	1	6	10 (1.0, 7)	NOTE 2
Steering stem lock nut	1	22	74 (7.5, 54)	See page 12-29
Steering stem bearing adjusting nut	1	22	-	See page 12-29
Fork bottom bridge pinch bolt	2	8	26 (2.7, 20)	
Fork top bridge pinch bolt	2	7	18 (1.8, 13)	
Fork socket bolt	2	8	20 (2.0, 14)	NOTE 2
Spoke	36	-	3 (0.3, 2)	
Rim lock	1	8	12 (1.2, 9)	
Fork bolt	2	22	23 (2.3, 17)	
Fender stay bolt	3	6	12 (1.2, 9)	

#### REAR WHEEL/BRAKE/SUSPENSION

ITEM	Q'TY	THREAD DIA. (mm)	TORQUE N·m (kgf·m, lbf·ft)	REMARKS
Rear axle nut	1	12	62 (6.3, 46)	NOTE 1
Driven sprocket nut	4	8	32 (3.3, 24)	NOTE 1
Swingarm pivot nut	1	12	64 (6.5, 47)	NOTE 1
Shock absorber mounting nut (upper)	1	10	44 (4.5, 33)	NOTE 1
Shock absorber mounting nut (lower)	1	8	34 (3.5, 25)	NOTE 1
Shock absorber arm nut (swingarm side)	1	10	44 (4.5, 33)	NOTE 1
Shock absorber connecting rod nut	2	10	44 (4.5, 33)	NOTE 1
Rear brake arm nut	1	6	10 (1.0, 7)	NOTE 1
Spoke	36	-	3 (0.3, 2)	
Rim lock	1	8	12 (1.2, 9)	
Foot peg mounting bolt	4	10	55 (5.6, 41)	



**LUBRICATION & SEAL POINTS****ENGINE**

LOCATION	MATERIAL	REMARKS
Crankshaft connecting rod small end Crankshaft connecting rod big end Piston ring grooves Piston outer surface Piston pin bore Cam chain whole surface Valve adjusting screw lock nut Oil pump rotor Primary drive gear teeth Flywheel nut Clutch outer sliding surface Clutch friction disk whole surface Each oil seal lip Each bearing rotating area Each O-ring Other rotating and sliding surfaces	Engine oil	
Piston pin whole surface Camshaft whole surface Rocker arm shaft whole surface Valve stem sliding surface Transmission gear rotating surface Transmission gear teeth and shift fork groove	Molybdenum disulfide oil (a mixture of 1/2 engine oil and 1/2 molybdenum disulfide grease)	
Pulse generator mounting bolt threads	Locking agent	

## GENERAL INFORMATION

### FRAME

LOCATION	MATERIAL	REMARKS
Steering stem upper/lower bearing Steering stem upper/lower dust seal lips	Urea based multi-purpose grease for extreme pressure (example: EXCELITE EP2 manufactured by KYODO YUSHI, Japan) or equivalent	Apply 3 – 5 g
Brake cam (sliding surface and shoe contacting area) Brake anchor pin Brake cam dust seal Wheel hub dust seal lips Swingarm pivot thrust bush rolling area Swingarm pivot sliding surface Swingarm pivot dust seal lips Side stand pivot Brake lever pivot bolt sliding surface Rear brake pedal pivot sliding surface Throttle grip pipe sliding surface and cable rolling area Clutch lever pivot bolt sliding surface Kickstarter pedal joint movable area	Multi-purpose grease	Apply 0.5 – 1 g Apply 0.5 – 1 g
Shock absorber arm bush rolling area  Shock absorber arm dust seal lips surface Shock absorber connecting rod bush rolling area Shock absorber connecting rod dust seal lips surface	Molybdenum disulfide paste	
Fork oil seal lips and dust seal lips Damper oil seal lips	Fork fluid	
Handlebar grip inner surface	Honda Bond A or Honda Hand Grip Cement (U.S.A. only)	
Front brake arm pinch bolt threads Fork socket bolt threads	Locking agent	

CABLE & HARNESS ROUTING

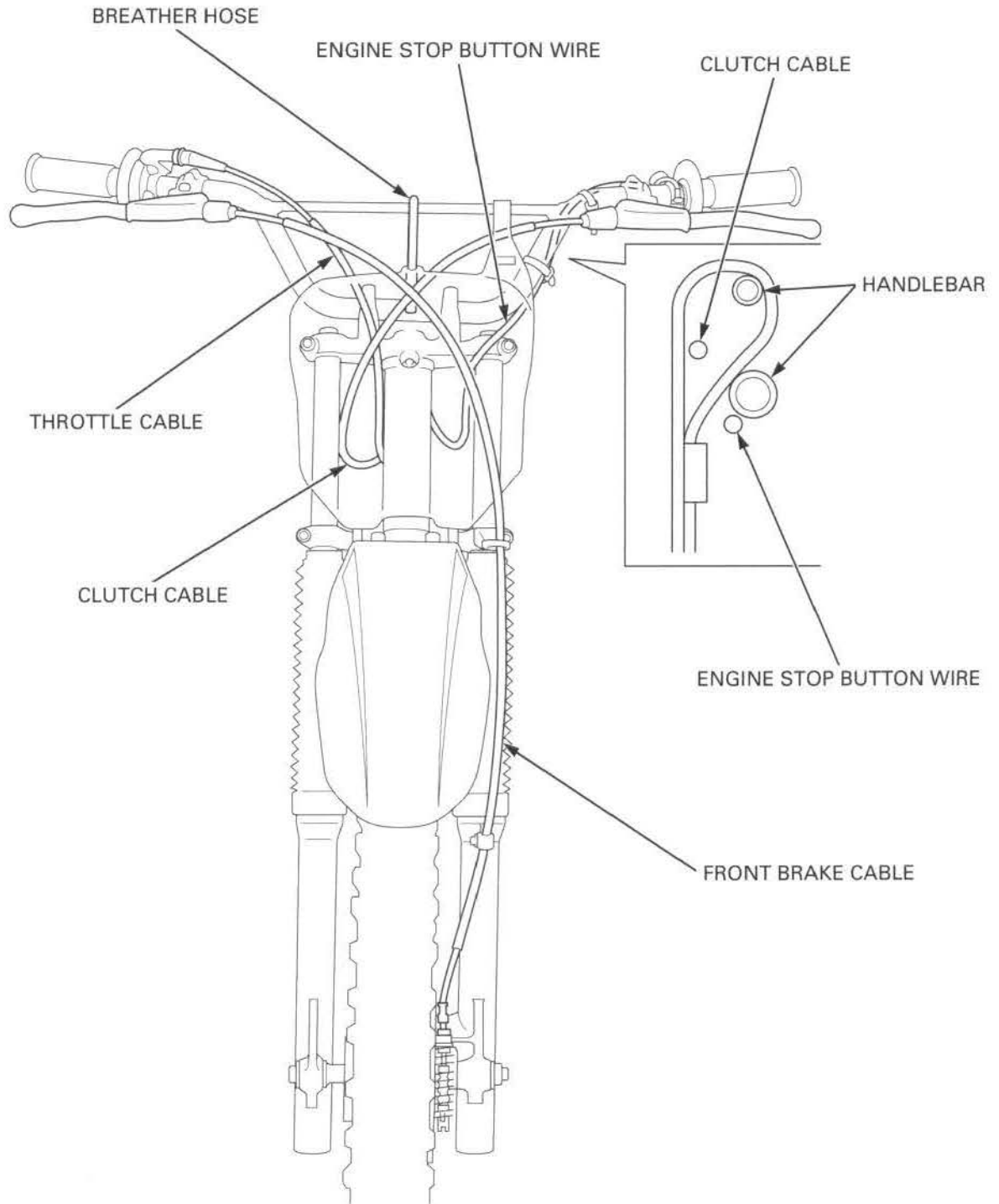

# GENERAL INFORMATION

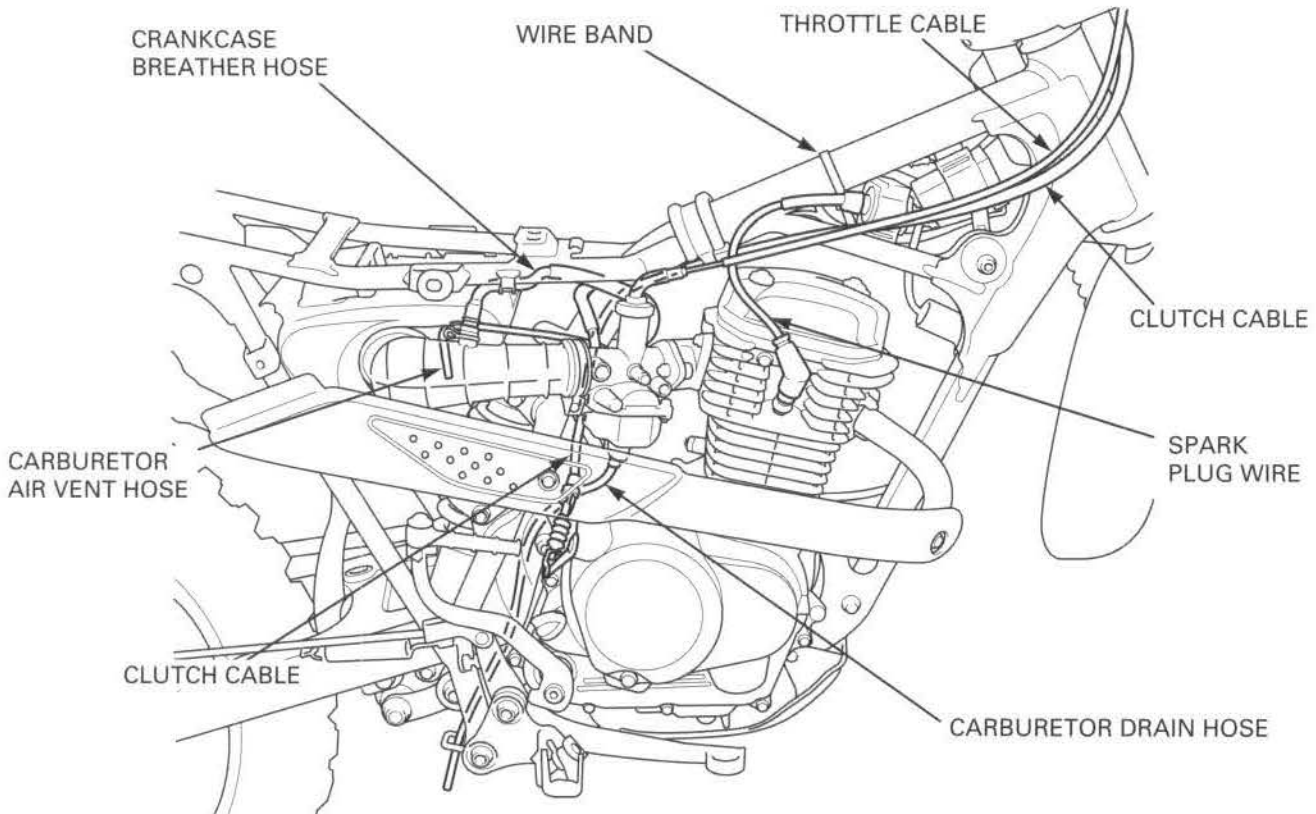
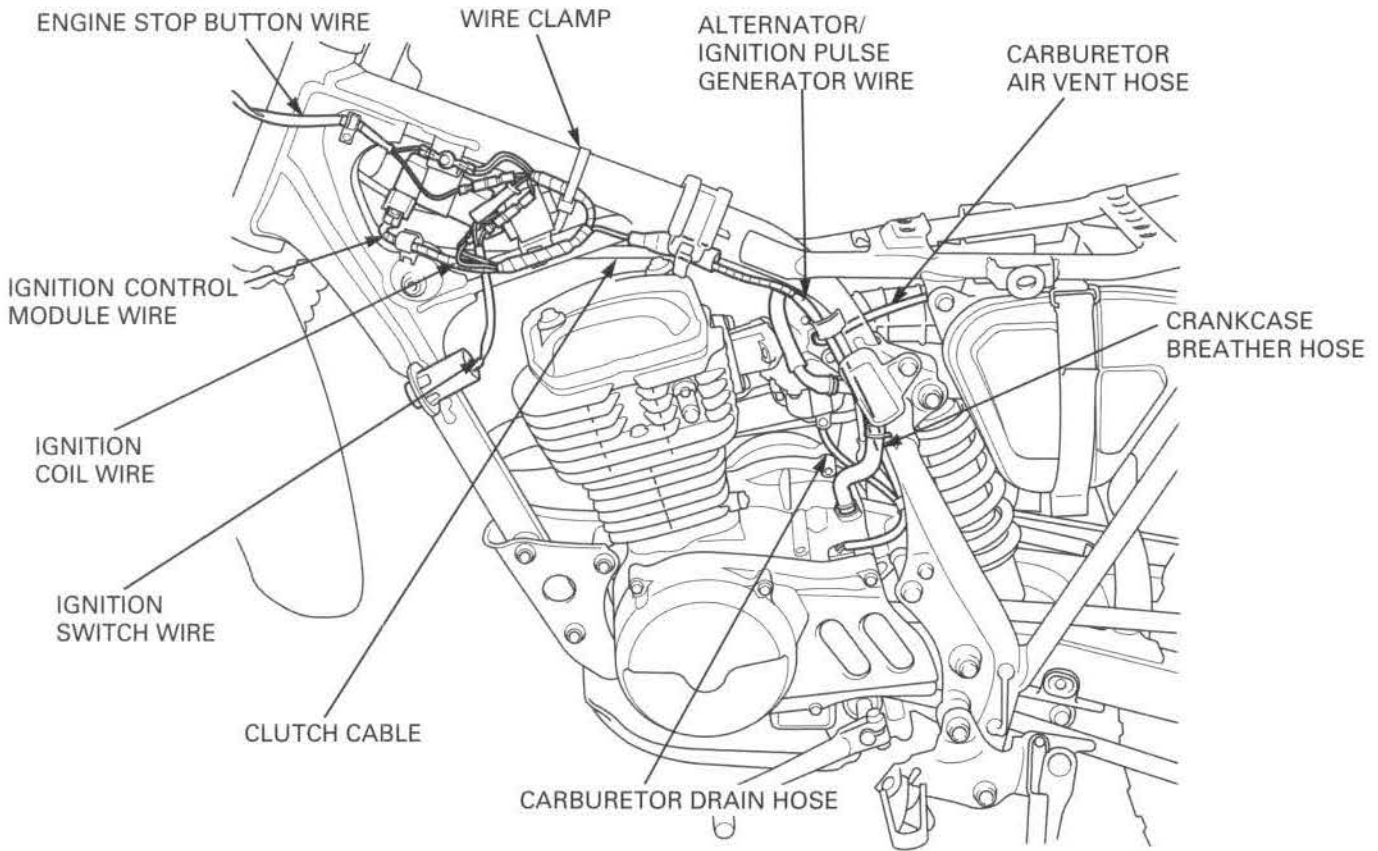

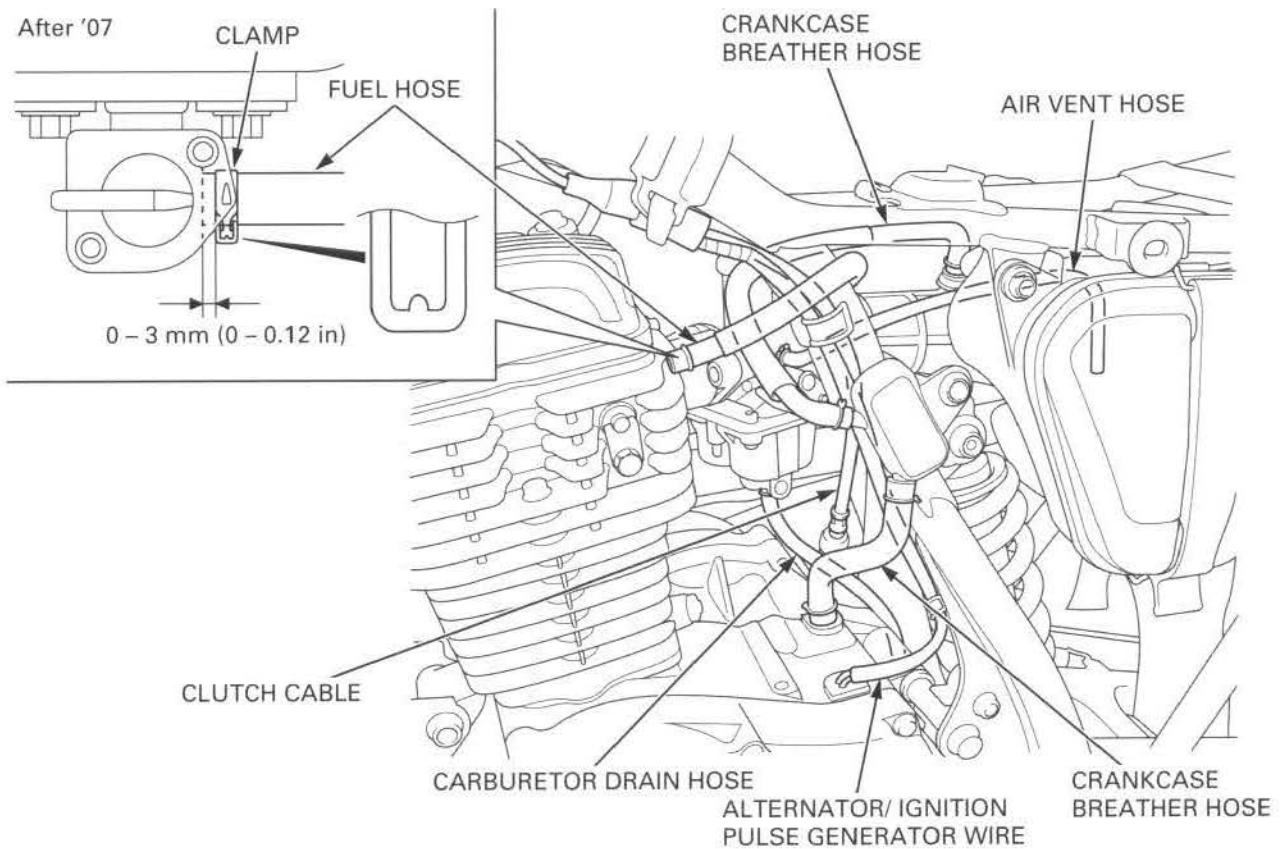
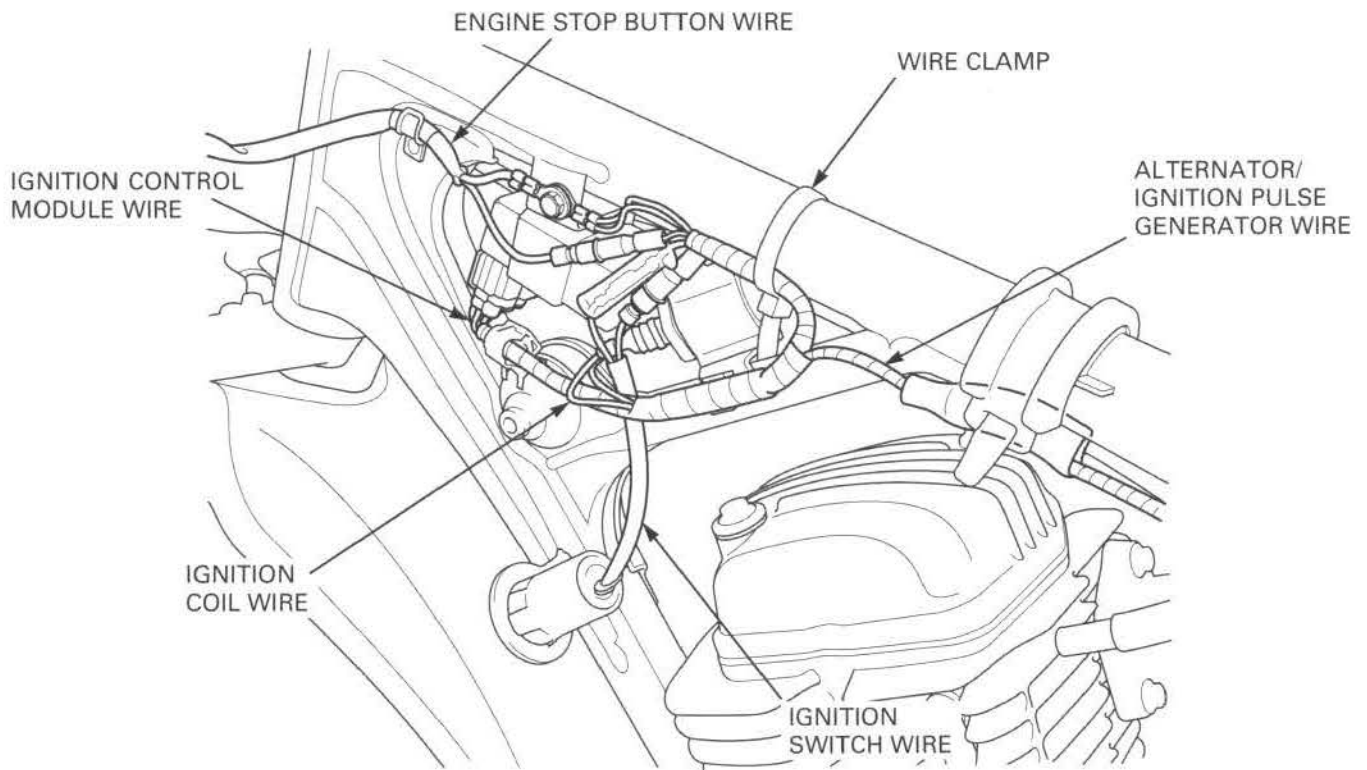



# GENERAL INFORMATION

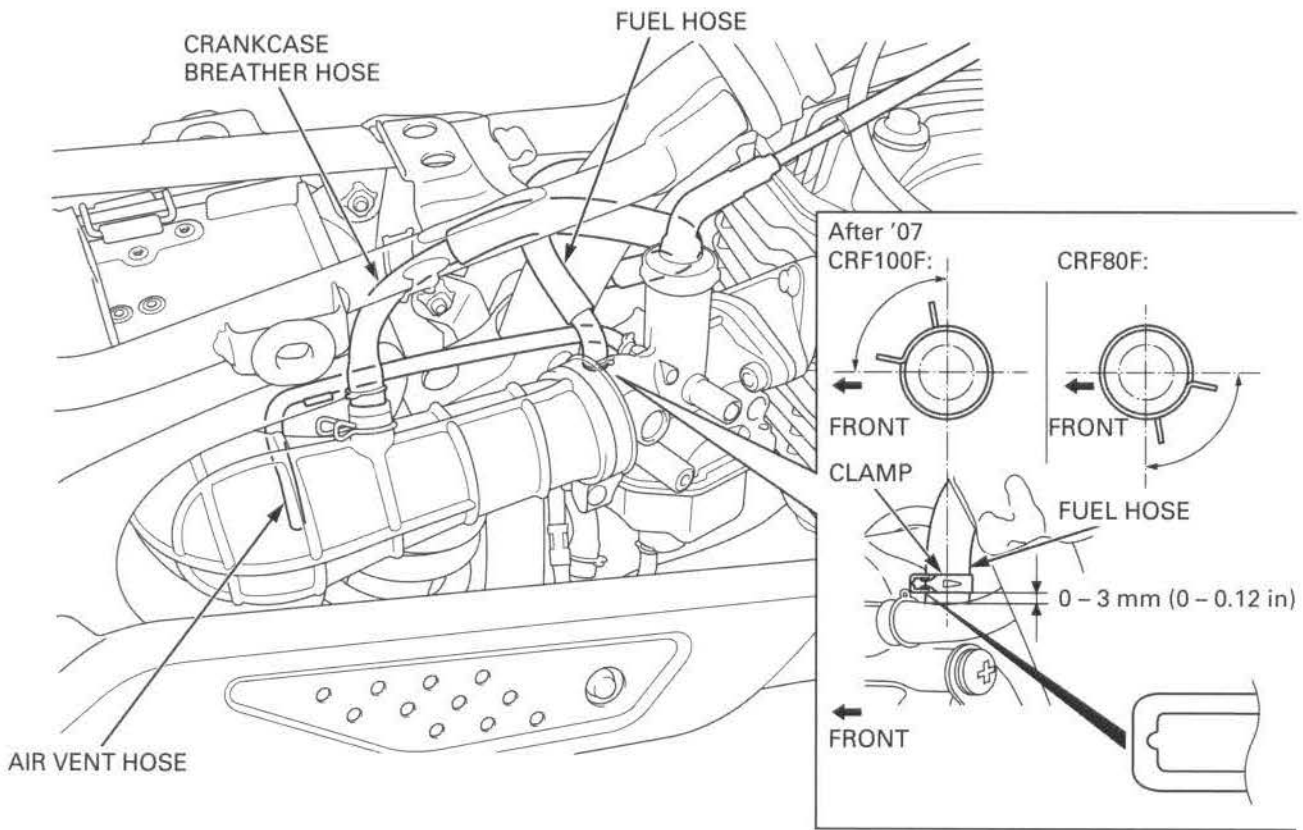

## EMISSION CONTROL SYSTEMS

The U.S. Environmental Protection Agency (EPA), and the California Air Resources Board (CARB) require that off-road motorcycles comply with applicable exhaust emissions standards during its useful life, when operated and maintained according to the instructions provided.

### SOURCE OF EMISSIONS

The combustion process produces oxides of nitrogen, carbon monoxide and hydrocarbons. Control of oxides of nitrogen and hydrocarbons is very important because, under certain conditions, they react to form photochemical smog when subjected to sunlight. Carbon monoxide does not react in the same way, but it is toxic.

Honda Motor Co., Ltd. utilizes appropriate carburetor settings as well as other systems, to reduce carbon monoxide and hydrocarbons.

### EXHAUST EMISSION CONTROL SYSTEM

The exhaust emission control system is composed of appropriate carburetor settings, no adjustment should be made except for high altitude setting and idle speed adjustment with the throttle stop screw. The exhaust emission control system is separate from the crankcase emission control system.

### CRANKCASE EMISSION CONTROL SYSTEM

The engine is equipped with a closed crankcase system to prevent discharging crankcase emissions into the atmosphere. Blow-by gas is returned to the combustion chamber through the air cleaner and carburetor.

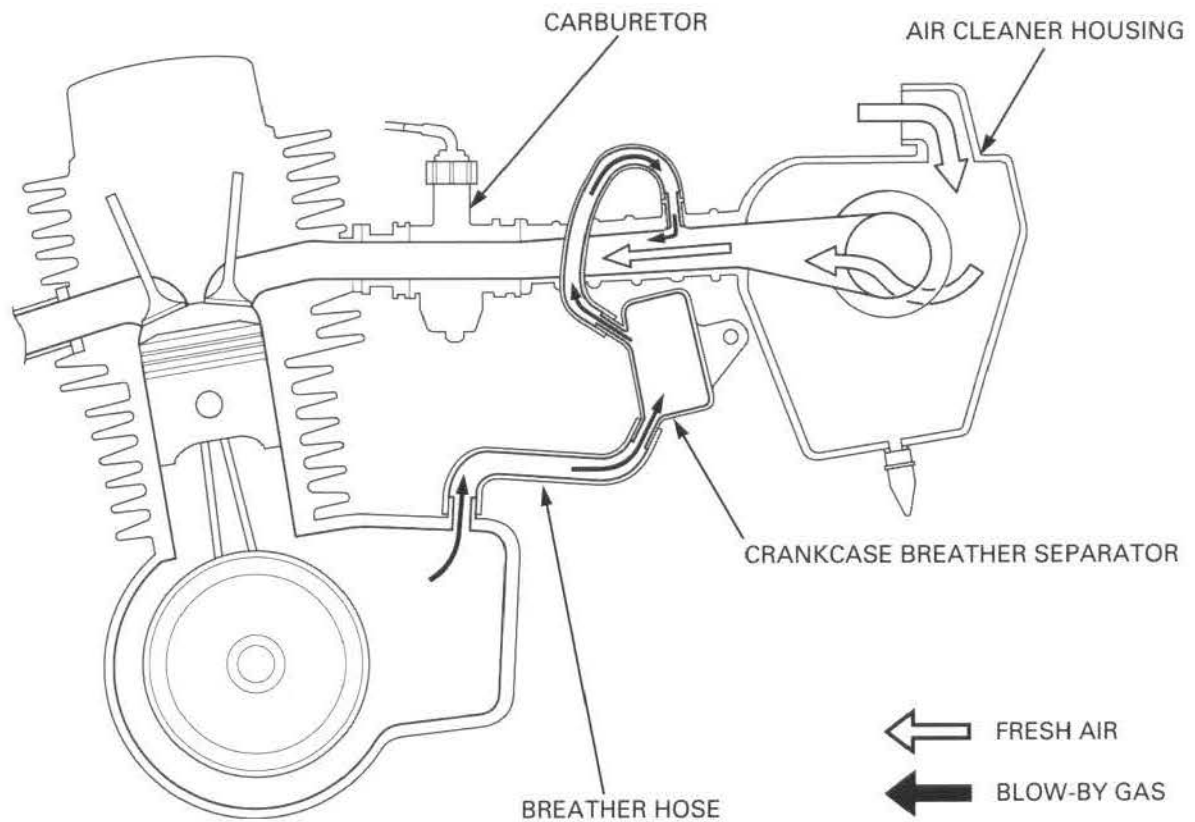

## GENERAL INFORMATION

---

### SERVICING THE HONDA

#### U.S.A. Only

Maintenance, replacement or repair of the emission control devices and systems may be performed by any motorcycle repair establishment or individual using parts that are "certified" to EPA standards.

#### PROHIBITED ACTIONS

The following prohibitions apply to everyone with respect to the engines emission control system.

You may not remove or disable any device or element of design that may affect an engine's emission levels. This restriction applies before and after the engine is placed in service.

Vehicles that are used only for competition are exempt from this prohibition.

#### NOISE EMISSION CONTROL SYSTEM

TAMPERING WITH THE NOISE CONTROL SYSTEM IS PROHIBITED: U.S. Federal law prohibits, or Canadian provincial law may prohibit the following acts or the causing thereof: (1) the removal or rendering inoperative by any person, other than for purposes of maintenance, repair or replacement, of any device or element of design incorporated into any new vehicle for purpose of noise control prior to its sale or delivery to the ultimate purchaser or while it is in use; or (2) the use of the vehicle after such device or element of design has been removed or rendered inoperative by any person.

AMONG THOSE ACTS PRESUMED TO CONSTITUTE TAMPERING ARE THE ACTS LISTED BELOW:

1. Removal of, or puncturing of the muffler, baffles, header pipes or any other component which conducts exhaust gases.
2. Removal of, or puncturing of any part of the intake system.
3. Lack of proper maintenance.
4. Replacing any moving parts of the vehicle, or parts of the exhaust or intake system, with parts other than those specified by the manufacturer.

#### FUEL PERMEATION EMISSION CONTROL SYSTEM

This motorcycle complies with the Fuel Permeation Emission Control regulations of the U.S. Environmental Protection Agency (EPA), California Air Resources Board (CARB), and Environment Canada (EC). The fuel tank, fuel hoses, and fuel vapor charge hoses used on this motorcycle incorporate fuel permeation control technologies. Tampering with the fuel tank, fuel hoses, or fuel vapor charge hoses to reduce or defeat the effectiveness of the fuel permeation technologies is prohibited by federal regulations.

#### REBUILT ENGINE

When you rebuild your engine including a major overhaul in which you replace the engine's pistons or power assemblies or make other changes that significantly increase the service life of the engine, your Honda will continue to comply with all emissions regulations if you:

- Make sure you are technically qualified to rebuild the engine and have the proper tools
- Use only Genuine Honda parts or equivalents
- Make sure to maintain all specifications as described in this Service Manual

# 2. FRAME/BODY PANELS/EXHAUST SYSTEM

---

SERVICE INFORMATION .....	2-2	NUMBER PLATE .....	2-5
TROUBLESHOOTING .....	2-2	FRONT FENDER .....	2-5
BODY PANEL LOCATIONS .....	2-2	REAR FENDER .....	2-5
SIDE COVER .....	2-3	MUD GUARD .....	2-6
SEAT .....	2-3	CRANKCASE PROTECTOR .....	2-6
TANK SHROUD .....	2-3	MUFFLER/EXHAUST PIPE .....	2-7
FUEL TANK .....	2-4		

## SERVICE INFORMATION

### GENERAL

- This section covers removal and installation of the body panels, fuel tank and exhaust system.
- Serious burns may result if the exhaust system is not allowed to cool before components are removed or serviced.
- Always replace the exhaust pipe gaskets after removing the exhaust pipe from the engine.
- When installing the exhaust system, loosely install all of the exhaust pipe fasteners first. Always tighten the exhaust clamps first, then tighten the mounting fasteners. If you tighten the mounting fasteners first, the exhaust pipe may not seat properly.
- Always inspect the exhaust system for leaks after installation.

### TORQUE VALUES

Exhaust pipe/muffler mounting bolt	26 N·m (2.7 kgf·m, 20 lbf·ft)	
Exhaust pipe joint nut	12 N·m (1.2 kgf·m, 9 lbf·ft)	
Exhaust pipe protector bolt	14 N·m (1.4 kgf·m, 10 lbf·ft)	
Front fender bolt/nut	12 N·m (1.2 kgf·m, 9 lbf·ft)	
Fuel tank mounting bolt	12 N·m (1.2 kgf·m, 9 lbf·ft)	
Front engine hanger nut	34 N·m (3.5 kgf·m, 25 lbf·ft)	U-nut

## TROUBLESHOOTING

### Excessive exhaust noise

- Broken exhaust system
- Exhaust gas leak

### Poor performance

- Deformed exhaust system
- Exhaust gas leak
- Clogged muffler

## BODY PANEL LOCATIONS

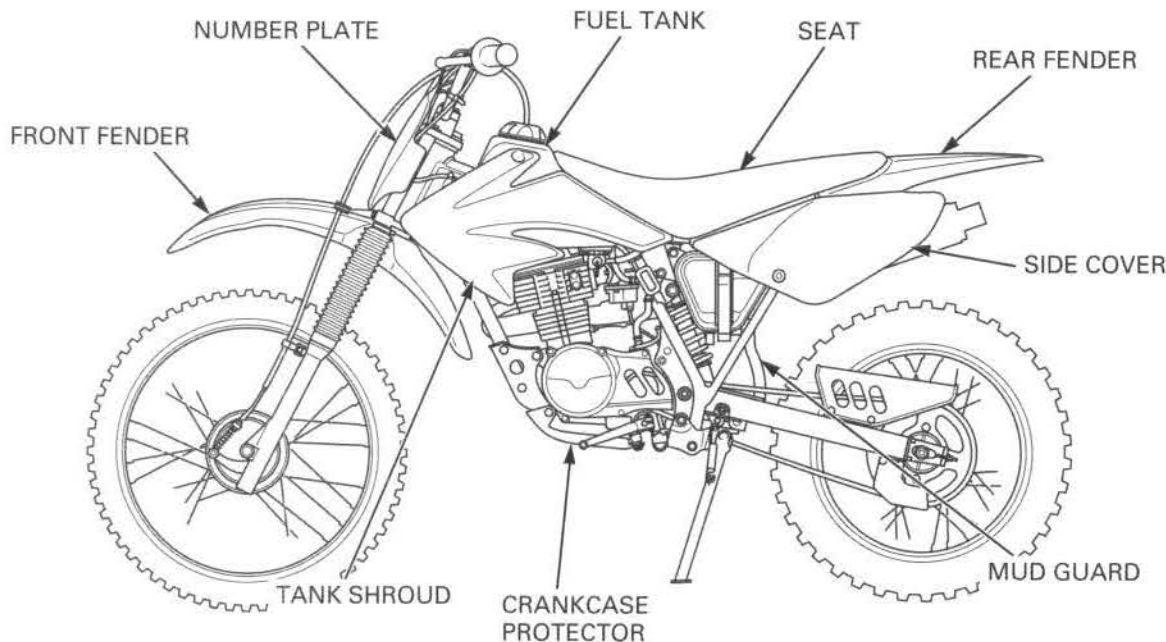



## SIDE COVER

### REMOVAL/INSTALLATION

Remove the bolt and side cover.

Installation is in the reverse order of removal.

**NOTE:**

Align the boss on the side cover with the hole.

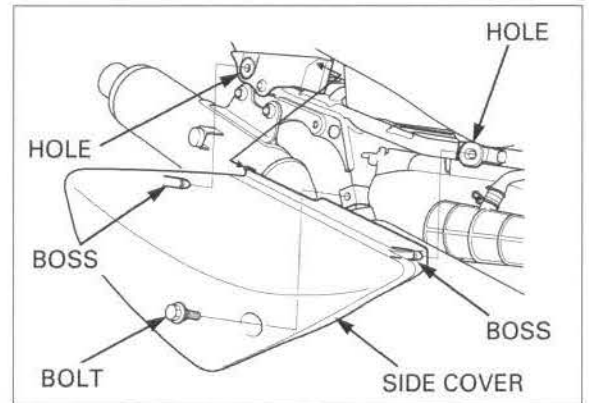

## SEAT

### REMOVAL/INSTALLATION

Remove the nuts and collars.

Remove the seat.

Installation is in the reverse order of removal.

**NOTE:**

When installing the seat, align the seat hook with the screw on the fuel tank, and also align the prong with the frame clamp.

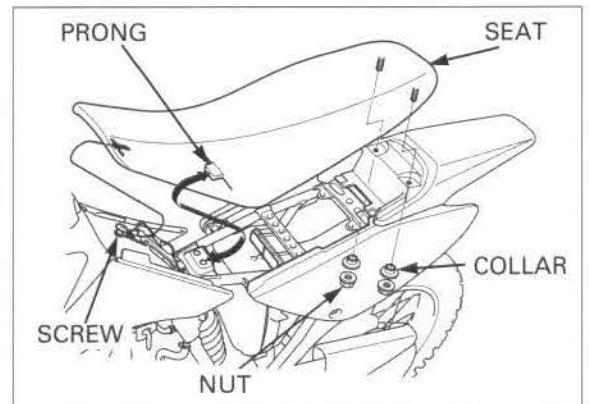

## TANK SHROUD

### REMOVAL/INSTALLATION

Remove the bolt and trim clip.

Remove the tank shroud from the fuel tank.

Installation is in the reverse order of removal.

**NOTE:**

Align the hole in the shroud with the boss on the fuel tank.

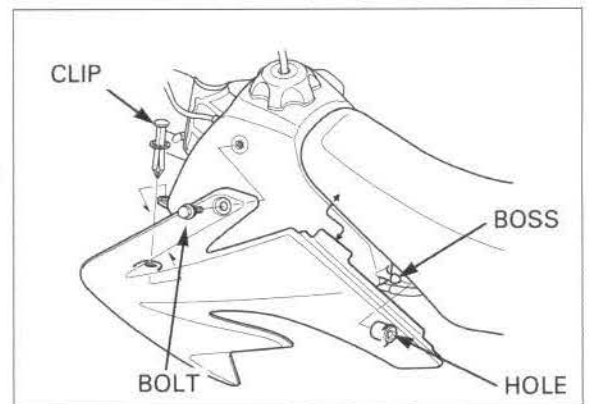

## FUEL TANK

### REMOVAL/INSTALLATION

Turn the fuel valve OFF.

Remove the seat (page 2-3).

Remove the tank shroud (page 2-3).

Disconnect the fuel hose from the fuel valve.

Disconnect the fuel tank breather hose from the number plate.

Remove the fuel tank holder band.

Remove the fuel tank mounting bolts and fuel tank.

Installation is in the reverse order of removal.

### TORQUE:

Fuel tank mounting bolt: 12 N·m (1.2 kgf·m, 9 lbf·ft)

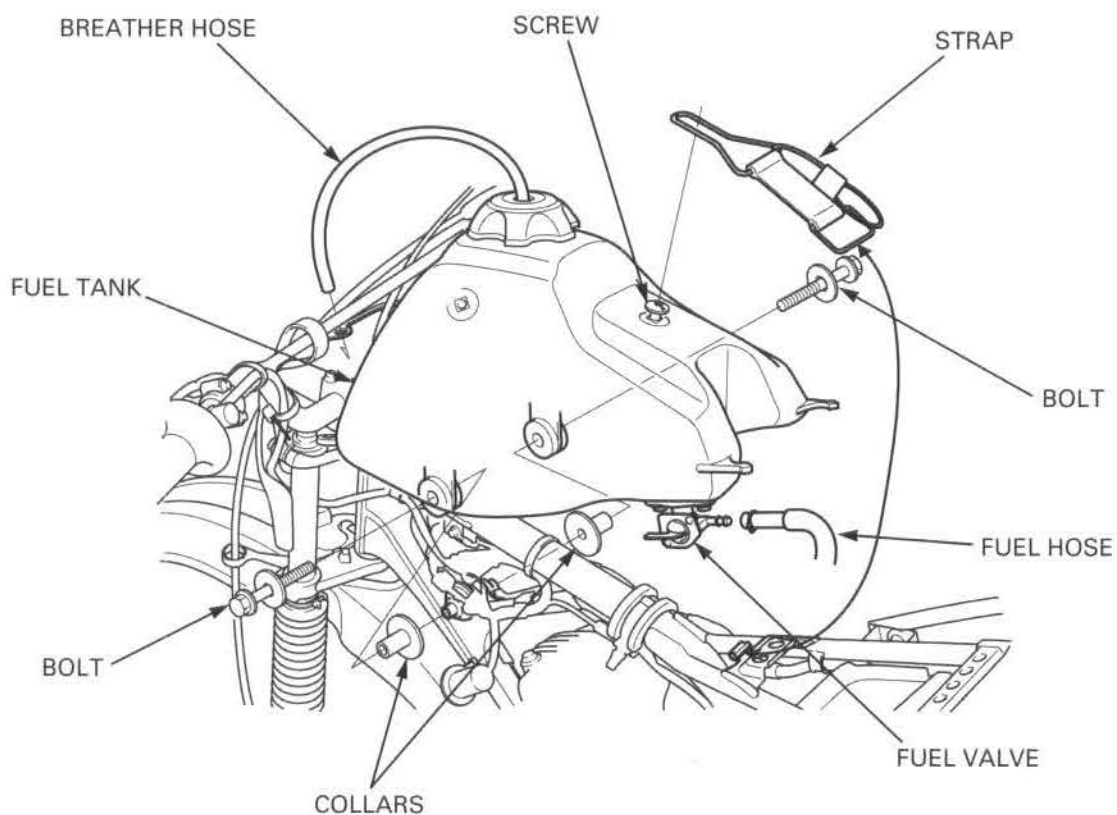

## NUMBER PLATE

### REMOVAL/INSTALLATION

Unfasten the number plate from the handlebar.

Remove the bolt and number plate.

Installation is in the reverse order of removal.

#### NOTE:

During installation, align the lower grooves with the bracket tabs on the steering stem.

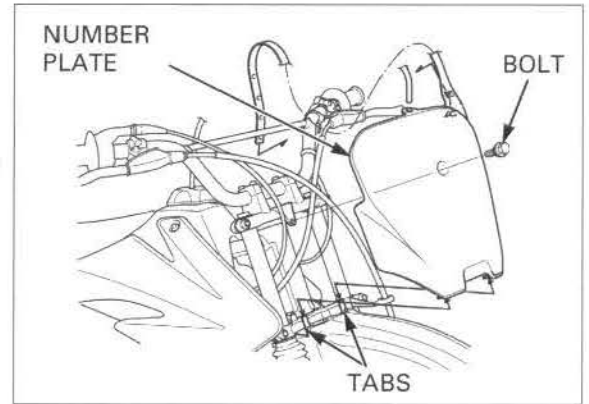

## FRONT FENDER

### REMOVAL/INSTALLATION

Remove the bolt, nuts, collars and front fender.

Installation is in the reverse order of removal.

**TORQUE:** 12 N·m (1.2 kgf·m, 9 lbf·ft)

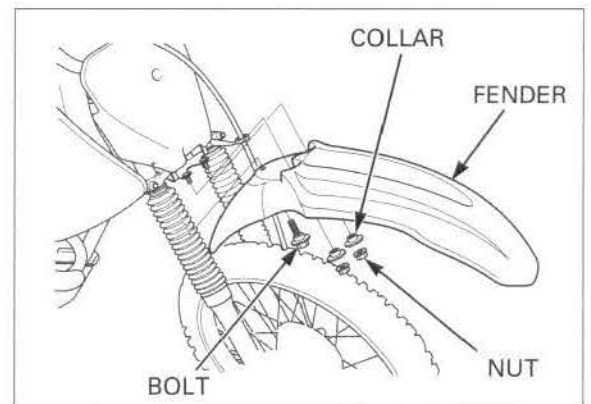

## REAR FENDER

### REMOVAL/INSTALLATION

Remove the seat and side covers (page 2-3).

Remove the bolts and rear fender.

Installation is in the reverse order of removal.

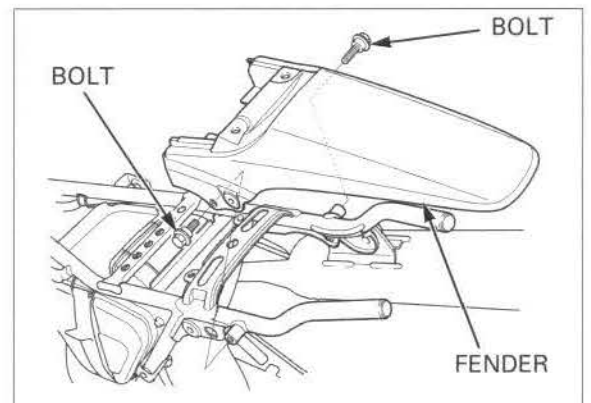

## MUD GUARD

### REMOVAL/INSTALLATION

Remove the two bolts and mud guard.  
Installation is in the reverse order of removal.

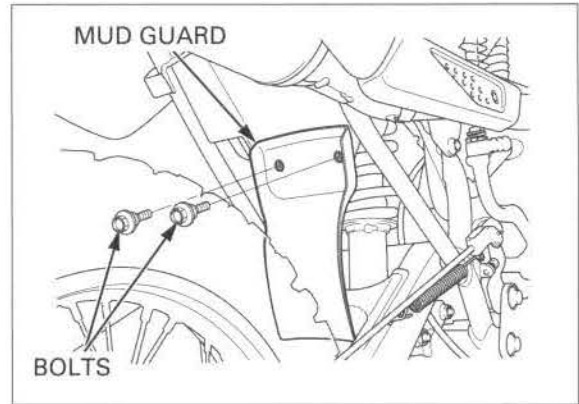

## CRANKCASE PROTECTOR

### REMOVAL

Remove the two crankcase protector bolts.



Remove the front engine hanger bolt/nut and crankcase protector.

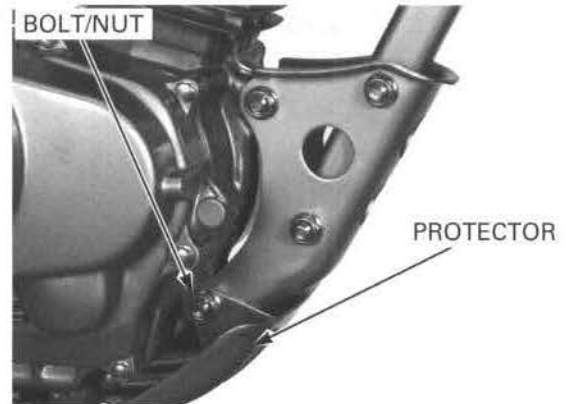

Inspect the stopper rubber for wear or damage, replace if necessary.



**INSTALLATION**

Place the crankcase protector and install the front engine hanger bolt from the left side.

Temporarily install the two crankcase protector bolts.

Tighten the front engine hanger nut to the specified torque.

**TORQUE: 34 N·m (3.5 kgf·m, 25 lbf·ft)**

Tighten the two crankcase protector bolts.

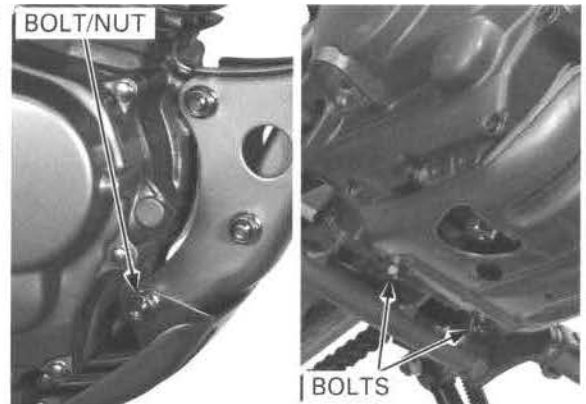

**MUFFLER/EXHAUST PIPE**

**REMOVAL**

Remove the right side cover (page 2-3).

Remove the exhaust pipe joint nuts.

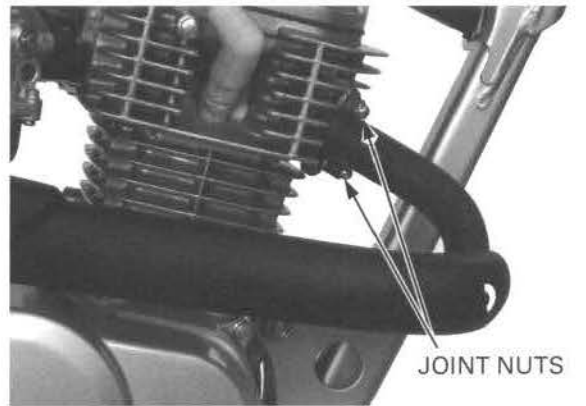

Remove the exhaust pipe/muffler mounting bolts and exhaust pipe/muffler assembly.

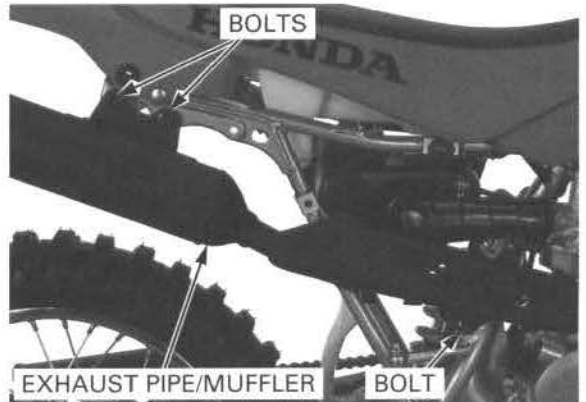



## INSTALLATION

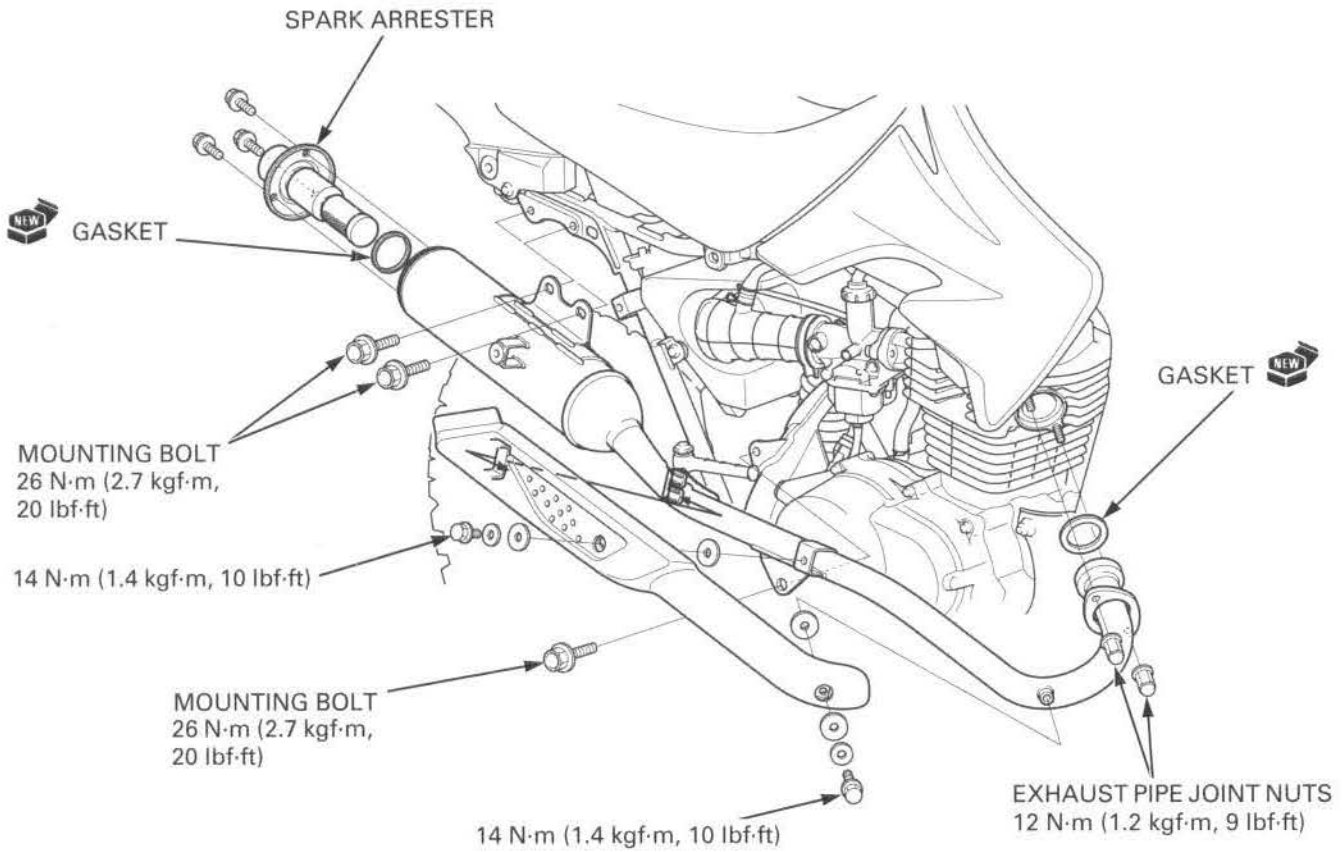

*Always replace the exhaust pipe gasket with a new one.*

Install a new exhaust pipe gasket onto the exhaust port of the cylinder head.

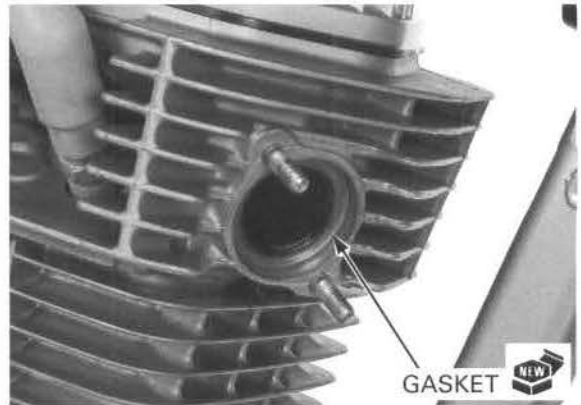

GASKET

Install the exhaust pipe, temporarily install the exhaust pipe joint nuts and mounting bolts.

First tighten the exhaust pipe joint nuts to the specified torque.

**TORQUE: 12 N·m (1.2 kgf·m, 9 lbf·ft)**

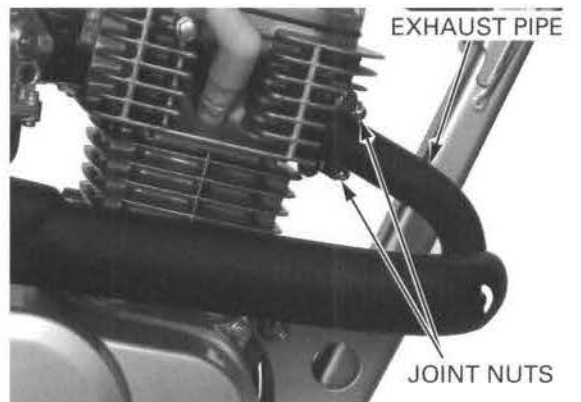

EXHAUST PIPE

JOINT NUTS

Tighten the exhaust pipe/muffler mounting bolts to the specified torque.

**TORQUE: 26 N·m (2.7 kgf·m, 20 lbf·ft)**

Install the side cover (page 2-3).

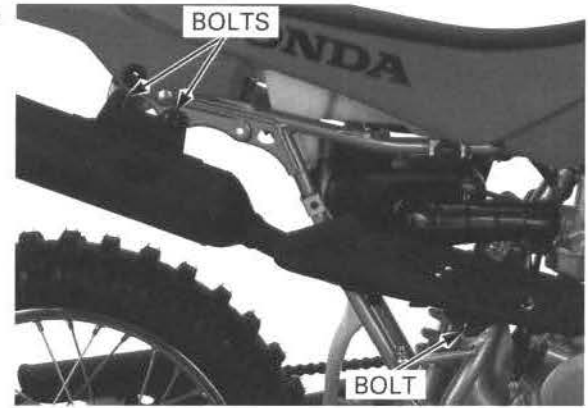

SERVICE INFORMATION .....	3-2	DRIVE CHAIN.....	3-17
MAINTENANCE SCHEDULE .....	3-5	DRIVE CHAIN SLIDER .....	3-19
FUEL LINE .....	3-9	BRAKE SHOE WEAR .....	3-20
THROTTLE OPERATION.....	3-9	BRAKE SYSTEM.....	3-20
AIR CLEANER.....	3-10	CLUTCH SYSTEM .....	3-22
SPARK PLUG .....	3-11	SIDE STAND .....	3-23
VALVE CLEARANCE.....	3-12	SUSPENSION .....	3-23
ENGINE OIL.....	3-13	SPARK ARRESTER.....	3-24
ENGINE OIL STRAINER SCREEN .....	3-15	NUTS, BOLTS, FASTENERS.....	3-25
CAM CHAIN TENSION .....	3-15	WHEELS/TIRES .....	3-25
ENGINE IDLE SPEED .....	3-16	STEERING HEAD BEARINGS .....	3-26

## MAINTENANCE

# SERVICE INFORMATION

## GENERAL

- Place the motorcycle on a level surface before starting any work.
- The exhaust contains poisonous carbon monoxide gas that may cause loss of consciousness and may lead to death. Run the engine in an open area or with an exhaust evacuation system in an enclosed area.

## SPECIFICATIONS

CRF100F:

ITEM		SPECIFICATIONS	
Throttle grip free play		2 – 6 mm (1/12 – 1/4 in)	
Spark plug		NGK	DENSO
	Standard	CR7HSA	U22FSR-U
	For cold climate (below 5°C/41°F)	CR6HSA	U20FSR-U
	For extended high speed riding	CR8HSA	U24FSR-U
Spark plug gap		0.6 – 0.7 mm (0.024 – 0.028 in)	
Valve clearance	IN	0.05 mm (0.002 in)	
	EX	0.05 mm (0.002 in)	
Engine oil capacity	At draining	0.9 liter (1.0 US qt, 0.8 Imp qt)	
	At disassembly	1.1 liter (1.2 US qt, 1.0 Imp qt)	
Recommended engine oil		Pro Honda GN4 4-stroke oil (U.S.A and Canada) or equivalent motor oil API service classification: SG or higher JASO T 903 standard: MA Viscosity: SAE 10W-30	
Engine idle speed		1,400 ± 100 rpm	
Drive chain slack		25 – 35 mm (1.0 – 1.4 in)	
Drive chain size/link		RK	RK428FDZ-118RJ
Brake lever free play		20 – 30 mm (3/4 – 1-1/4 in)	
Brake pedal free play		20 – 30 mm (3/4 – 1-1/4 in)	
Clutch lever free play		10 – 20 mm (3/8 – 3/4 in)	
Tire size	Front	70/100-19 M/C 42M	
	Rear	90/100-16 M/C 51M	
Tire brand	Front	Cheng shin	
	Rear	Cheng shin	
Cold tire pressure	Front	100 kPa (1.00 kgf/cm <sup>2</sup> , 14 psi)	
	Rear	100 kPa (1.00 kgf/cm <sup>2</sup> , 14 psi)	

CRF80F:

ITEM		SPECIFICATIONS	
Throttle grip free play		2 – 6 mm (1/12 – 1/4 in)	
Spark plug		NGK	DENSO
	Standard	CR7HSA	U22FSR-U
	For cold climate (below 5°C/41°F)	CR6HSA	U20FSR-U
	For extended high speed riding	CR8HSA	U24FSR-U
Spark plug gap		0.6 – 0.7 mm (0.024 – 0.028 in)	
Valve clearance	IN	0.05 mm (0.002 in)	
	EX	0.05 mm (0.002 in)	
Engine oil capacity	At draining	0.9 liter (1.0 US qt, 0.8 Imp qt)	
	At disassembly	1.1 liter (1.2 US qt, 1.0 Imp qt)	
Recommended engine oil		Pro Honda GN4 4-stroke oil (U.S.A and Canada) or equivalent motor oil API service classification: SG or higher JASO T 903 standard: MA Viscosity: SAE 10W-30	
Engine idle speed		1,500 ± 100 rpm	
Drive chain slack		25 – 35 mm (1.0 – 1.4 in)	
Drive chain size/link	RK	RK420MSZ1-110RJ	
	DID	DID420MBK1-110RB	
Brake lever free play		20 – 30 mm (3/4 – 1-1/4 in)	
Brake pedal free play		20 – 30 mm (3/4 – 1-1/4 in)	
Clutch lever free play		10 – 20 mm (3/8 – 3/4 in)	
Tire size	Front	2.50-16 4PR	
	Rear	3.60-14 4PR	
Tire brand	Front	IRC	
	Rear	IRC	
Cold tire pressure	Front	100 kPa (1.00 kgf/cm <sup>2</sup> , 14 psi)	
	Rear	100 kPa (1.00 kgf/cm <sup>2</sup> , 14 psi)	

### TORQUE VALUES

Spark plug	14 N·m (1.4 kgf·m, 10 lbf·ft)
Oil drain bolt	24 N·m (2.5 kgf·m, 18 lbf·ft)
Rear axle nut	62 N·m (6.3 kgf·m, 46 lbf·ft)
Side stand pivot bolt	10 N·m (1.0 kgf·m, 7 lbf·ft)
Side stand pivot nut	39 N·m (4.0 kgf·m, 29 lbf·ft)
Valve adjusting screw lock nut	10 N·m (1.0 kgf·m, 7 lbf·ft)
Cam chain tensioner adjusting bolt lock nut	12 N·m (1.2 kgf·m, 9 lbf·ft)
Spoke	3 N·m (0.3 kgf·m, 2 lbf·ft)
Rim rock	12 N·m (1.2 kgf·m, 9 lbf·ft)

#### U-nut

Loosen the bolt 1/8 to 1/4 turns after tightening it to the specified torque, then tighten the pivot nut.

Apply oil to the threads and seating surface

# MAINTENANCE

## TOOLS

Valve adjusting wrench, 8 x 9 mm  
07708-0030100



or equivalent commercially available in U.S.A.

Valve adjuster B  
07908-KE90000

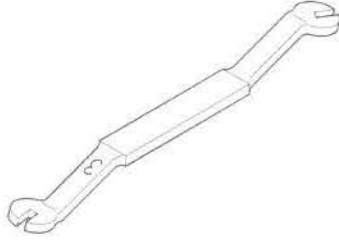

or 07908-KE90200 (U.S.A. only)

Spoke wrench, 4.5 x 5.1 mm  
07701-0020200



or equivalent commercially available in U.S.A.

# MAINTENANCE SCHEDULE

## CRF100F ('04 AND '05):

Perform the Pre-ride inspection in the Owner's Manual at each scheduled maintenance period.

I: Inspect and Clean, Adjust, Lubricate or Replace if necessary. C: Clean. R: Replace. A: Adjust. L: Lubricate.

The following items require some mechanical knowledge. Certain items (particularly those marked \* and \*\*) may require more technical information and tools. Consult an authorized Honda dealer.

ITEMS	FREQUENCY	WHICHEVER COMES FIRST	REGULAR MAINTENANCE INTERVAL					REFER TO PAGE	
			mi	100	600	1,200	1,800		2,400
				km	150	1,000	2,000		3,000
NOTE	MONTH	1	6	12	18	24			
EMMISSION RELATED ITEMS	* FUEL LINE				I		I	3-9	
	** FUEL STRAINER SCREEN				C		C	3-9	
	* THROTTLE OPERATION				I		I	3-9	
	AIR CLEANER	NOTE 1		C	C	C	C	3-11	
	SPARK PLUG			I	I	I	I	3-11	
	* VALVE CLEARANCE		I	I	I	I	I	3-12	
	ENGINE OIL		R	R	R	R	R	3-13	
	** ENGINE OIL STRAINER SCREEN				C		C	3-15	
	* CAM CHAIN TENSION		A	A	A	A	A	3-15	
	** ENGINE IDLE SPEED		I	I	I	I	I	3-16	
NON-EMMISSION RELATED ITEMS	DRIVE CHAIN	NOTE 1	I, L	I, L: Every 300 mi (500 km) or 3 month				3-17	
	DRIVE CHAIN SLIDER			I	I	I	I	3-19	
	BRAKE SHOE WEAR			I	I	I	I	3-20	
	BRAKE SYSTEM		I	I	I	I	I	3-20	
	CLUTCH SYSTEM		I	I	I	I	I	3-22	
	SIDE STAND				I		I	3-23	
	* SUSPENSION				I		I	3-23	
	* SPARK ARRESTER			C: Every 1,000 mi (1,600 km) or every 100 operating hours				3-24	
	* NUTS, BOLTS, FASTENERS		I		I		I	3-25	
	** WHEELS/TIRES		I	I	I	I	I	3-25	
** STEERING HEAD BEARINGS		I		I		I	3-26		

\* Should be serviced by an authorized Honda dealer, unless the owner has proper tools and service data and is mechanically qualified.

\*\* In the interest of safety, we recommended these items be serviced only by an authorized Honda dealer.

NOTES:

1. Service more frequently when ridden in wet or dusty conditions.



# MAINTENANCE

## CRF100F (AFTER '05):

Perform the Pre-ride inspection in the Owner's Manual at each scheduled maintenance period.

I: Inspect and Clean, Adjust, Lubricate or Replace if necessary. C: Clean. R: Replace. A: Adjust. L: Lubricate.

The following items require some mechanical knowledge. Certain items (particularly those marked \* and \*\*) may require more technical information and tools. Consult an authorized Honda dealer.

ITEMS	FREQUENCY	WHICHEVER COMES FIRST ➔	REGULAR MAINTENANCE INTERVAL					REFER TO PAGE	
			mi	100	600	1,200	1,800		2,400
			km	150	1,000	2,000	3,000		4,000
NOTE	MONTH	1	6	12	18	24			
* FUEL LINE					I		I	3-9	
** FUEL STRAINER SCREEN					C		C	3-9	
* THROTTLE OPERATION					I		I	3-9	
AIR CLEANER	NOTE 1			C	C	C	C	3-11	
SPARK PLUG				I	I	I	I	3-11	
* VALVE CLEARANCE			I	I	I	I	I	3-12	
ENGINE OIL			R	R	R	R	R	3-13	
** ENGINE OIL STRAINER SCREEN					C		C	3-15	
* CAM CHAIN TENSION			A	A	A	A	A	3-15	
** ENGINE IDLE SPEED			I	I	I	I	I	3-16	
DRIVE CHAIN	NOTE 1		I, L	I, L: Every 300 mi (500 km) or 3 month				3-17	
DRIVE CHAIN SLIDER				I	I	I	I	3-19	
BRAKE SHOE WEAR				I	I	I	I	3-20	
BRAKE SYSTEM			I	I	I	I	I	3-20	
CLUTCH SYSTEM			I	I	I	I	I	3-22	
SIDE STAND					I		I	3-23	
* SUSPENSION					I		I	3-23	
* SPARK ARRESTER			C: Every 1,000 mi (1,600 km) or every 100 operating hours					3-24	
* NUTS, BOLTS, FASTENERS			I		I		I	3-25	
** WHEELS/TIRES			I	I	I	I	I	3-25	
** STEERING HEAD BEARINGS			I		I		I	3-26	

\* Should be serviced by an authorized Honda dealer, unless the owner has proper tools and service data and is mechanically qualified.

\*\* In the interest of safety, we recommended these items be serviced only by an authorized Honda dealer.

### NOTES:

1. Service more frequently when ridden in wet or dusty conditions.

**CRF80F ('04 AND '05):**

Perform the Pre-ride inspection in the Owner's Manual at each scheduled maintenance period.

I: Inspect and Clean, Adjust, Lubricate or Replace if necessary. C: Clean. R: Replace. A: Adjust. L: Lubricate.

The following items require some mechanical knowledge. Certain items (particularly those marked \* and \*\*) may require more technical information and tools. Consult an authorized Honda dealer.

ITEMS	FREQUENCY	WHICHEVER COMES FIRST → NOTE	INITIAL MAINTENANCE		REGULAR MAINTENANCE INTERVAL					REFER TO PAGE
			mi	km	600	1,200	1,800	2,400		
			MONTH	1	6	12	18	24		
EMMISSION RELATED ITEMS	* FUEL LINE					I			I	3-9
	** FUEL STRAINER SCREEN					C			C	3-9
	* THROTTLE OPERATION					I			I	3-9
	AIR CLEANER	NOTE 1			C	C	C	C		3-11
	SPARK PLUG				I	I	I	I		3-11
	* VALVE CLEARANCE			I	I	I	I	I		3-12
	ENGINE OIL			R	R	R	R	R		3-13
	** ENGINE OIL STRAINER SCREEN					C			C	3-15
	* CAM CHAIN TENSION			A	A	A	A	A		3-15
	** ENGINE IDLE SPEED			I	I	I	I	I		3-16
	NON-EMMISSION RELATED ITEMS	DRIVE CHAIN	NOTE 1		I, L	I, L: Every 300 mi (500 km) or 3 month				
DRIVE CHAIN SLIDER					I	I	I	I		3-19
BRAKE SHOE WEAR					I	I	I	I		3-20
BRAKE SYSTEM				I	I	I	I	I		3-20
CLUTCH SYSTEM				I	I	I	I	I		3-22
SIDE STAND						I		I		3-23
* SUSPENSION						I		I		3-23
* SPARK ARRESTER					C: Every 1,000 mi (1,600 km) or every 100 operating hours					3-24
* NUTS, BOLTS, FASTENERS				I		I		I		3-25
** WHEELS/TIRES				I	I	I	I	I		3-25
** STEERING HEAD BEARINGS			I		I		I		3-26	

- \* Should be serviced by an authorized Honda dealer, unless the owner has proper tools and service data and is mechanically qualified.
- \*\* In the interest of safety, we recommended these items be serviced only by an authorized Honda dealer.

**NOTES:**

1. Service more frequently when ridden in wet or dusty conditions.

# MAINTENANCE

## CRF80F (AFTER '05):

Perform the Pre-ride inspection in the Owner's Manual at each scheduled maintenance period.

I: Inspect and Clean, Adjust, Lubricate or Replace if necessary. C: Clean. R: Replace. A: Adjust. L: Lubricate.

The following items require some mechanical knowledge. Certain items (particularly those marked \* and \*\*) may require more technical information and tools. Consult an authorized Honda dealer.

ITEMS	FREQUENCY	WHICHEVER COMES FIRST		INITIAL MAINTENANCE	REGULAR MAINTENANCE INTERVAL				REFER TO PAGE
		↔	mi	100	600	1,200	1,800	2,400	
			km	150	1,000	2,000	3,000	4,000	
		NOTE	MONTH	1	6	12	18	24	
* FUEL LINE						I		I	3-9
** FUEL STRAINER SCREEN						C		C	3-9
* THROTTLE OPERATION						I		I	3-9
AIR CLEANER		NOTE 1			C	C	C	C	3-11
SPARK PLUG					I	I	I	I	3-11
* VALVE CLEARANCE				I	I	I	I	I	3-12
ENGINE OIL				R	R	R	R	R	3-13
** ENGINE OIL STRAINER SCREEN						C		C	3-15
* CAM CHAIN TENSION				A	A	A	A	A	3-15
** ENGINE IDLE SPEED				I	I	I	I	I	3-16
DRIVE CHAIN		NOTE 1		I, L	I, L: Every 300 mi (500 km) or 3 month				3-17
DRIVE CHAIN SLIDER					I	I	I	I	3-19
BRAKE SHOE WEAR					I	I	I	I	3-20
BRAKE SYSTEM				I	I	I	I	I	3-20
CLUTCH SYSTEM				I	I	I	I	I	3-22
SIDE STAND						I		I	3-23
* SUSPENSION						I		I	3-23
* SPARK ARRESTER				C: Every 1,000 mi (1,600 km) or every 100 operating hours					3-24
* NUTS, BOLTS, FASTENERS				I		I		I	3-25
** WHEELS/TIRES				I	I	I	I	I	3-25
** STEERING HEAD BEARINGS				I		I		I	3-26

\* Should be serviced by an authorized Honda dealer, unless the owner has proper tools and service data and is mechanically qualified.

\*\* In the interest of safety, we recommended these items be serviced only by an authorized Honda dealer.

### NOTES:

1. Service more frequently when ridden in wet or dusty conditions.

## FUEL LINE

Check the fuel line for deterioration, damage or leakage.

Replace the fuel line if necessary.

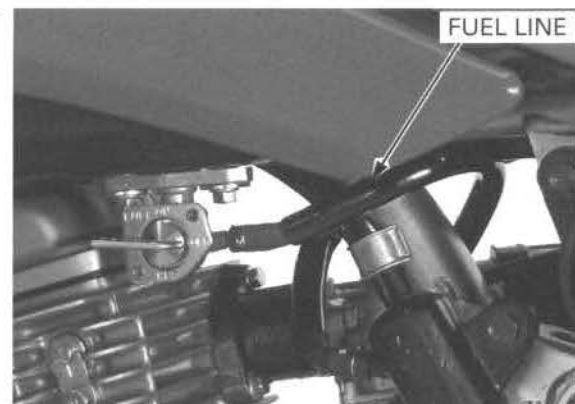

## FUEL STRAINER SCREEN

Turn the fuel valve to "OFF" position and disconnect the fuel hose from the carburetor.

Place a drain pan under the fuel hose and turn the fuel valve ON to drain the fuel tank.

After the tank has drained completely, remove the two bolts, fuel valve and fuel strainer screen.

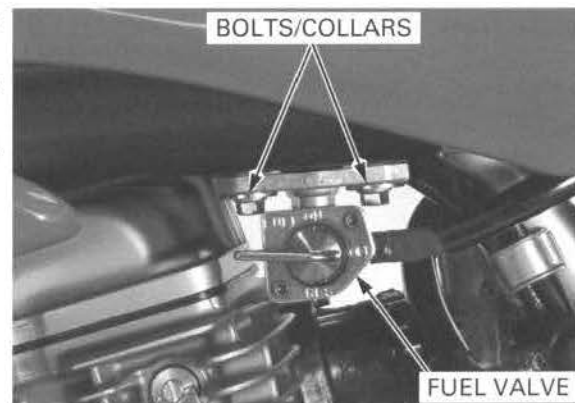

Wash the fuel strainer screen in non-flammable or high flash solvent.

Install a new O-ring to the fuel valve.

Install the fuel valve/strainer screen, collars and mounting bolts.

Tighten the fuel valve mounting bolts.

After installation, check for fuel leaks.

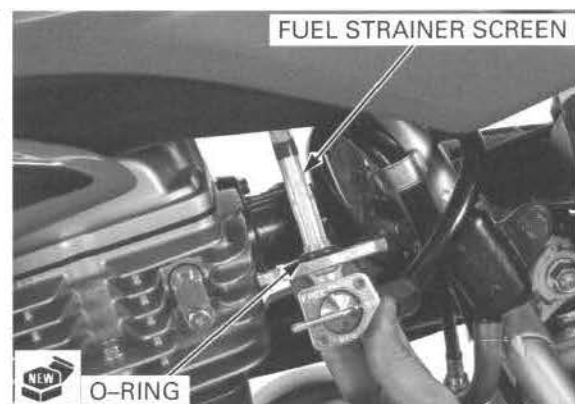

## THROTTLE OPERATION

Check for smooth throttle grip full opening and automatic full closing in all steering positions.

Check the throttle cable and replace it if deteriorated, kinked or damaged.

Lubricate the throttle cables if throttle operation is not smooth.

Measure the free play at the throttle grip flange.

**FREE PLAY: 2 – 6 mm (1/12 – 1/4 in)**

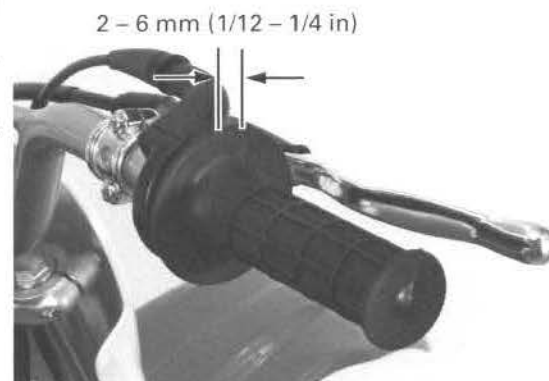

## MAINTENANCE

Throttle grip free play can be adjusted at the throttle housing adjuster.

Remove the dust cover from the adjuster.

Adjust the free play by loosening the lock nut and turning the adjuster.

Recheck the throttle operation.

Replace any damaged parts if necessary.

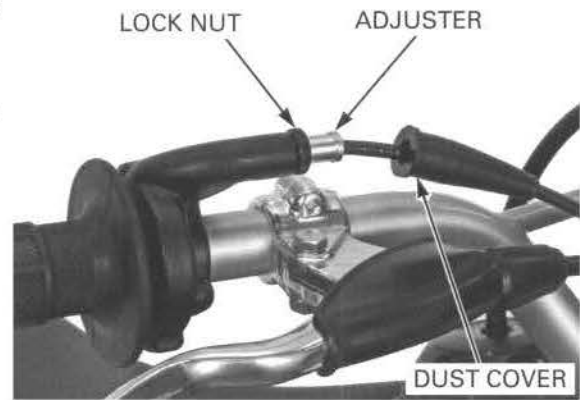

## AIR CLEANER

Remove the left side cover (page 2-3).

Remove the air cleaner housing cover band and housing cover.

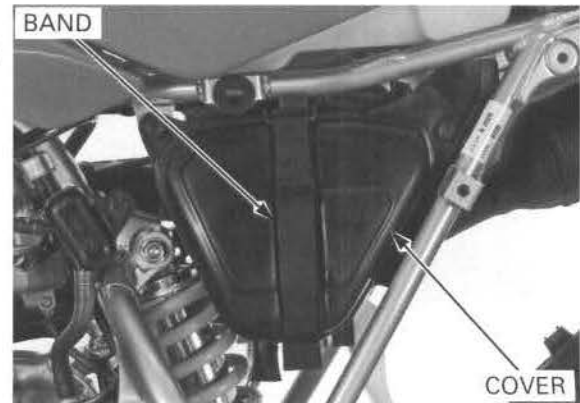

Release the air cleaner element holder band and air cleaner element from the housing.

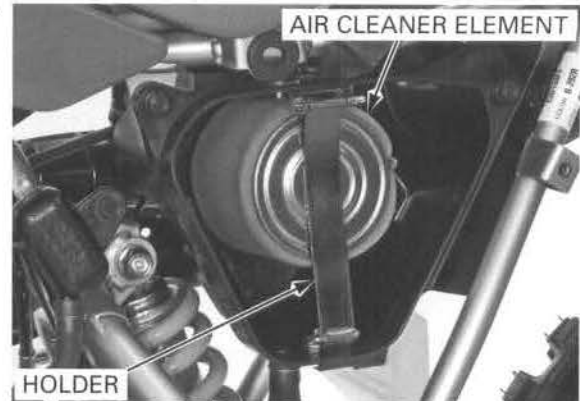

Wash the element in non-flammable or high flash point solvent and let it dry thoroughly.

Squeeze out the solvent thoroughly, and allow the element to dry.

Soak the element in Pro Honda Foam Filter Oil or equivalent and squeeze out any excess oil.

Installation is in the reverse order of removal.

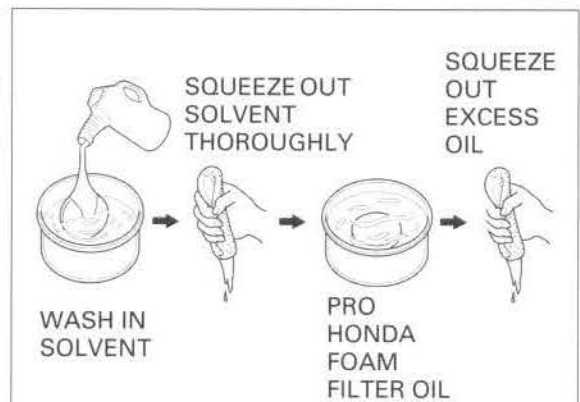

# SPARK PLUG

*Clean around the spark plug bases with compressed air before removing, and be sure that no debris is allowed to enter the combustion chamber.*

Disconnect the spark plug cap.

Remove the spark plug using a spark plug wrench or equivalent.

Inspect or replace as described in the maintenance schedule (page 3-5).

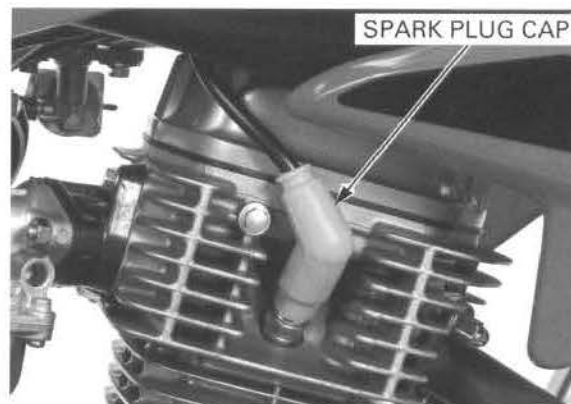

## INSPECTION

Check the following and replace if necessary (recommended spark plug: page 3-2):

- Insulator for damage
- Electrodes for wear
- Burning condition, coloration;
  - Dark to light brown indicates good condition.
  - Excessive lightness indicates malfunctioning ignition system or lean mixture.
  - Wet or black sooty deposit indicates over-rich mixture.

### SPECIFIED SPARK PLUG:

**NGK: CR7HSA**  
**DENSO: U22FSR-U**

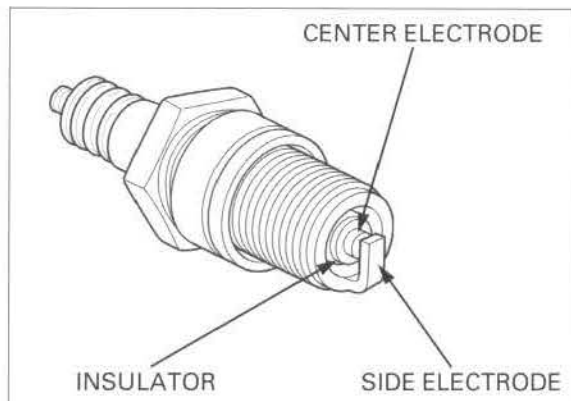

Clean the spark plug electrodes with a wire brush or special plug cleaner.

Check the gap between the center and side electrodes with a wire-type feeler gauge.

If necessary, adjust the gap by bending the side electrode carefully.

**SPARK PLUG GAP: 0.6 – 0.7 mm (0.024 – 0.028 in)**

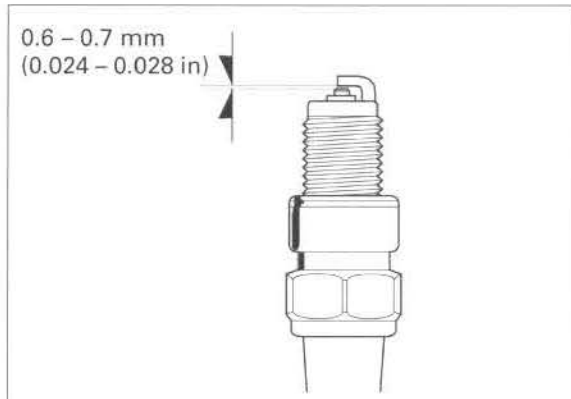

Install and hand tighten the spark plug to the cylinder head, then tighten the spark plug to the specified torque.

**TORQUE: 14 N·m (1.4 kgf·m, 10 lbf·ft)**

Install the spark plug cap.

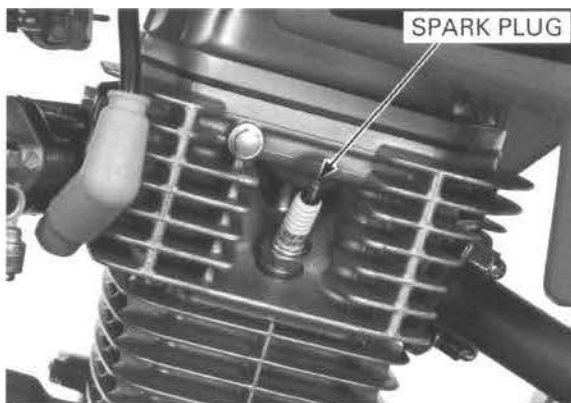

## VALVE CLEARANCE

### INSPECTION

*Inspect and adjust the valve clearance while the engine is cold (below 35°C/95°F)*

Remove the following.

- Side cover (page 2-3)
- Seat (page 2-3)
- Fuel tank (page 2-4)

Remove the two cylinder head cover bolt and cylinder head cover.

Remove the left crankcase cover (page 10-4).

Turn the crankshaft counterclockwise and align the "T" mark on the flywheel with the index notch on the left crankcase cover.

Make sure the piston is at TDC (Top Dead Center) on the compression stroke.

Check the valve clearance by inserting a feeler gauge between the valve adjusting screw and valve stem.

#### VALVE CLEARANCE:

IN/EX:0.05 mm (0.002 in)

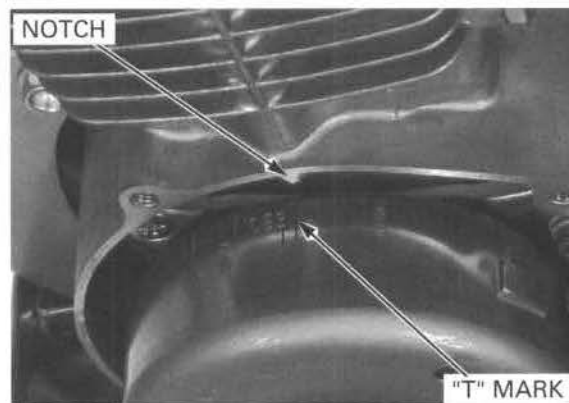
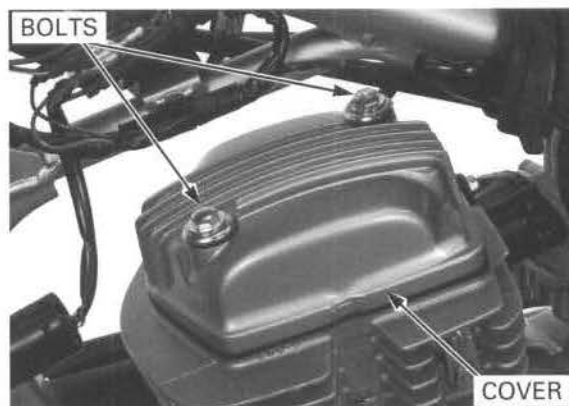



## ADJUSTMENT

Adjust by loosening the lock nut and turning the adjusting screw until there is a slight drag on the feeler gauge.

Hold the adjusting screw and tighten the lock nut to the specified torque.

### TOOLS:

Valve adjusting wrench,  
8 x 9 mm

Valve adjuster B

07708-0030100 or  
equivalent com-  
mercially avail-  
able in U.S.A.  
07908-KE90000 or  
07908-KE90200  
(U.S.A. only)

**TORQUE: 10 N-m (1.0 kgf-m, 7 lbf-ft)**

After tightening the valve adjuster lock nut, recheck the valve clearance.

Install the following:

- Cylinder head cover (page 7-20)
- Seat (page 2-3)
- Side cover (page 2-3)
- Left crankcase cover (page 10-8)

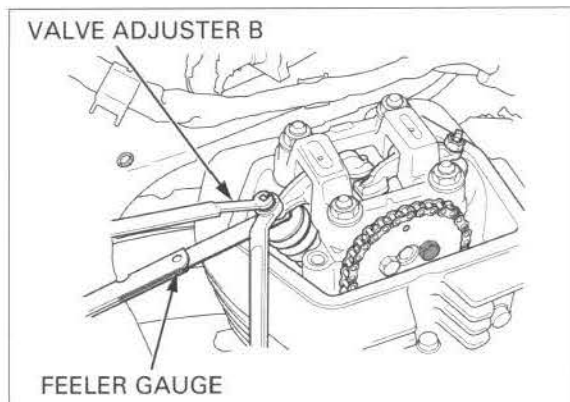

## ENGINE OIL

### ENGINE OIL LEVEL CHECK

Start the engine and let it idle for 3 – 5 minutes.

Stop the engine and wait 2 – 3 minutes.

Support the motorcycle in an upright position on level ground.

Remove the filler cap/dipstick and wipe it clean.

Reinstall the oil filler cap/dipstick, but do not screw in.

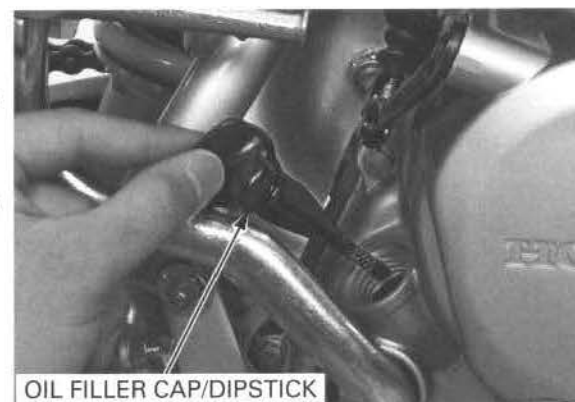

## MAINTENANCE

Remove the filler cap and check the oil level.

If the oil level is below the lower level line on the dipstick, fill the crankcase with the recommended oil.



*Other viscosities shown in the chart may be used when the average temperature in your riding area is within the indicated range.*

### RECOMMENDED ENGINE OIL:

**Pro Honda GN4 4-stroke oil (U.S.A and Canada) or equivalent motor oil**  
**API service classification: SG or higher**  
**JASO T 903 standard: MA**  
**Viscosity: SAE 10W-30**

Check that the O-ring is in good condition, replace if necessary.

Reinstall the oil filler cap/dipstick.

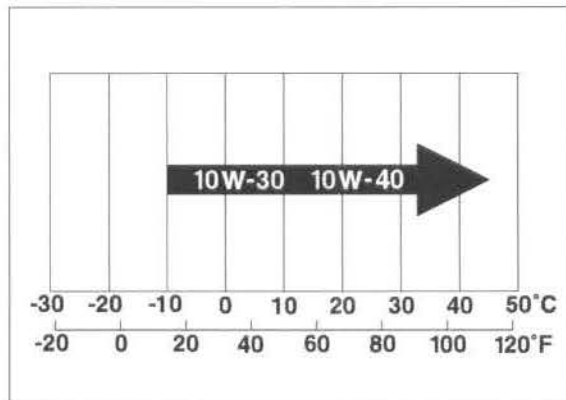

## ENGINE OIL CHANGE

*Change the engine oil with the engine warm and the motorcycle on level ground to assure complete draining.*

Warm up the engine.

Stop the engine and remove the oil filler cap/dipstick and drain bolt and sealing washer.

Drain the oil completely.

After the oil has drain completely, install the drain bolt with a new sealing washer.

Tighten the drain bolt to the specified torque.

**TORQUE: 24 N·m (2.5 kgf·m, 18 lbf·ft)**



Fill the crankcase with the recommended engine oil.

**OIL CAPACITY:**

**0.9 liter (1.0 US qt, 0.8 Imp qt) after draining**

Install the oil filler cap/dipstick.

Start the engine and let it idle for 2 to 3 minutes.

Stop the engine and recheck the oil level.

Check the engine oil level (page 3-13) and make sure there are no oil leaks.



**ENGINE OIL STRAINER SCREEN**

*Perform this maintenance before filling the engine with oil.*

Remove the right crankcase cover (page 9-5).

Remove the oil strainer screen and clean it.

Reinstall the oil strainer screen and right crankcase cover (page 9-14).

Fill the crankcase with recommended engine oil (page 3-14).



**CAM CHAIN TENSION**

Stop the engine.

Loosen the cam chain adjuster set plate bolt.

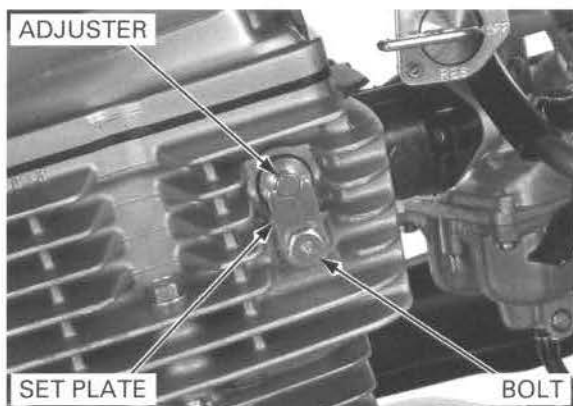

Turn the adjuster and set the punch mark at 45 degree downside (tension side) from the standard position.

Tighten the set plate bolt.

**NOTE:**

Do not turn the adjuster over 45 degree downside from the standard position to prevent the tensioner being too tensile.

Loosen the lock nut and the cam chain tensioner adjust screw.

**NOTE:**

The cam chain tension will be adjusted automatically by the tensile force of the cam chain tensioner spring when loosening the cam chain tensioner adjust screw.

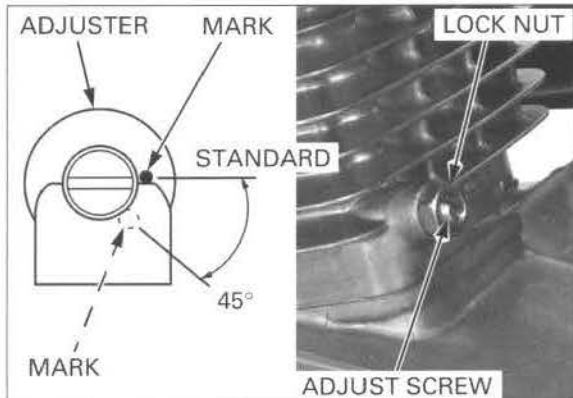

## MAINTENANCE

Tighten the cam chain tensioner adjust screw.

Tighten the lock nut to the specified torque with holding the adjust screw.

**TORQUE: 12 N·m (1.2 kgf·m, 9 lbf·ft)**

Loosen the cam chain tensioner adjuster set plate bolt and turn the adjuster and set punch mark to the standard position.

Tighten the cam chain tensioner adjuster set plate bolt.

Start the engine and check the chain noise.

If the cam chain is too tensile, turn the adjuster to the slack side and fine adjust.

After adjustment, tighten the cam chain tensioner adjuster set plate bolt.

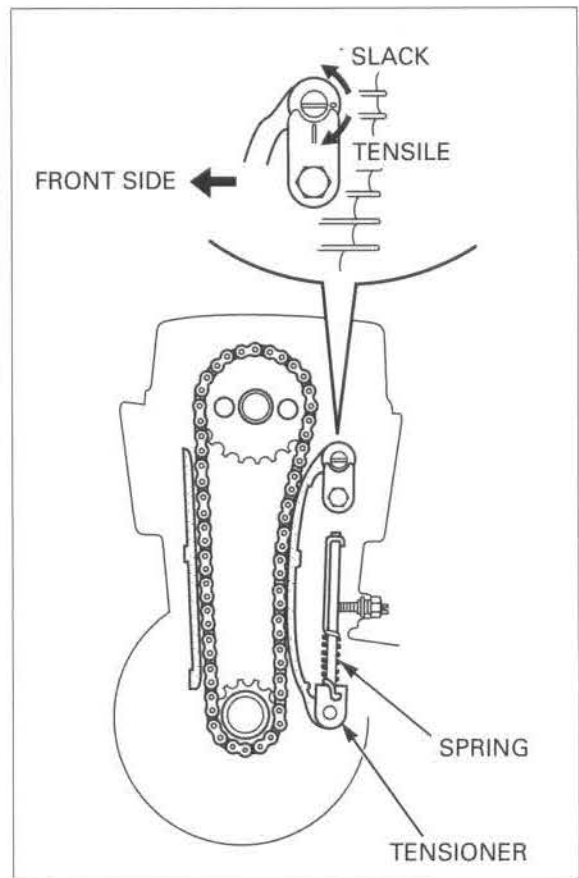

## ENGINE IDLE SPEED

- Inspect and adjust the idle speed after all other engine maintenance items have been performed and are within specifications.
- The engine must be warm for accurate idle speed inspection and adjustment.

Connect a tachometer.

Warm up the engine for about 10 minutes.

Turn the throttle stop screw as required to obtain the specified idle speed.

**IDLE SPEED:**

**CRF100F: 1,400 ± 100 rpm**

**CRF80F: 1,500 ± 100 rpm**

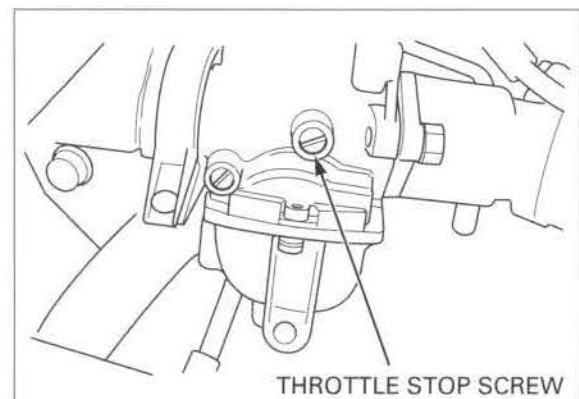
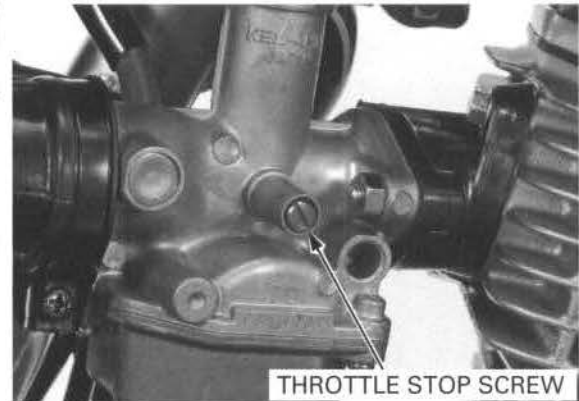

## DRIVE CHAIN

### DRIVE CHAIN SLACK INSPECTION

*Never inspect and adjust the drive chain while the engine is running.*

Turn the ignition switch OFF, place the motorcycle on its side stand and shift the transmission into neutral.

Check the slack in the drive chain lower run midway between the sprockets.

**CHAIN SLACK: 25 – 35 mm (1.0 – 1.4 in)**

#### NOTICE

*Excessive chain slack, 50 mm (2.0 in) or more, may damage the frame.*

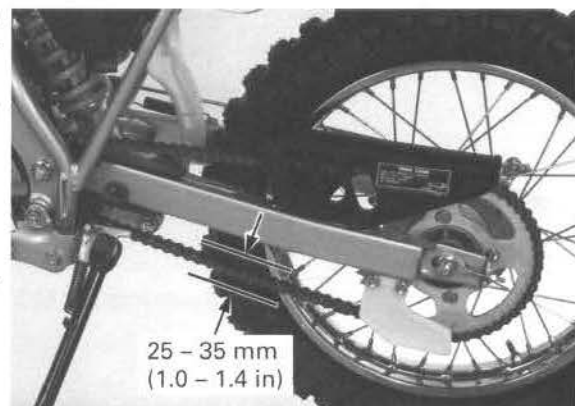

### ADJUSTMENT

Loosen the rear axle nut.

Turn both chain adjusting nuts equally until the chain slack is correct.

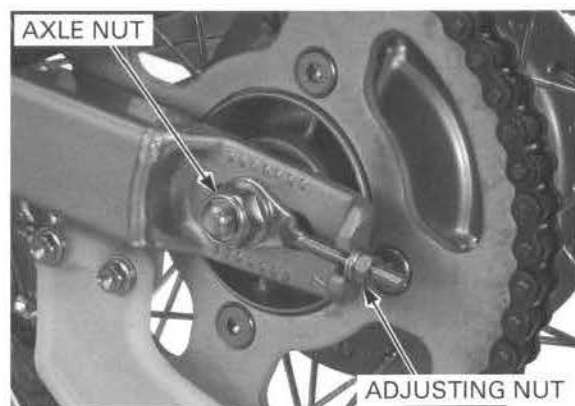

Make sure the index marks on both adjusters are aligned with the index marks on the swingarm.

Tighten the rear axle nut to the specified torque.

**TORQUE: 62 N·m (6.3 kgf·m, 46 lbf·ft)**

Tighten both adjusting nuts.

Recheck the drive chain slack and free wheel rotation.

Check the rear brake pedal free play (page 3-21), adjust if necessary.

Lubricate the drive chain with #80–90 gear oil or drive chain lubricant.

Wipe off any excess gear oil or drive chain lubricant.

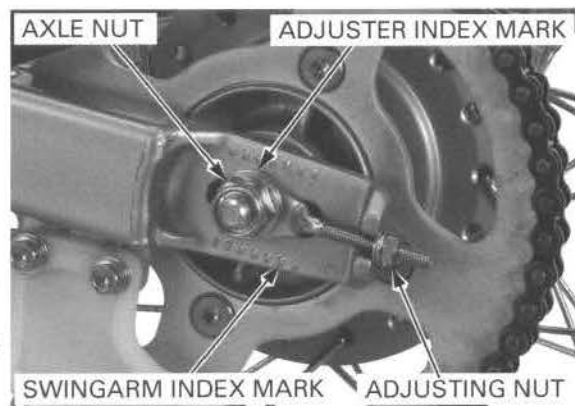

### CLEANING INSPECTION AND LUBRICATION

If the drive chain becomes extremely dirty, it should be removed and cleaned prior to lubrication.

Remove the left crankcase cover (page 10-4).

Carefully remove the retaining clip with pliers.

Remove the master link and drive chain.

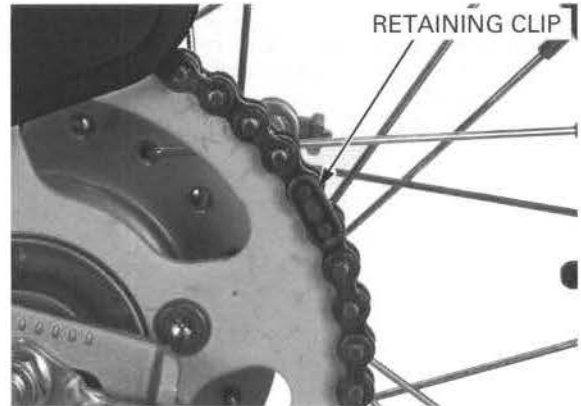

Clean the chain with non-flammable or high flash point solvent and wipe it dry.

Be sure the chain has dried completely before lubricating.

Inspect the drive chain for possible damage or wear.

Replace any chain that has damaged rollers, loose fitting links, or otherwise appears unserviceable.

Installing a new chain on badly worn sprockets will cause the new chain to wear quickly.

Inspect and replace sprocket if necessary.

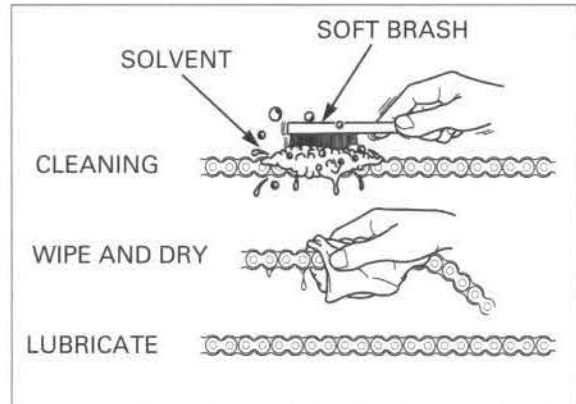

Lubricate the drive chain with #80-90 gear oil or drive chain lubricant.

Wipe off any excess gear oil or drive chain lubricant.

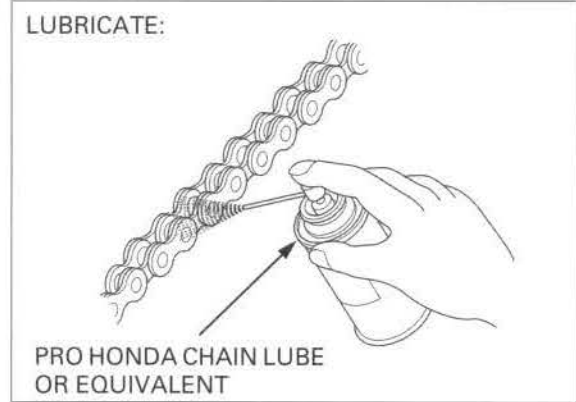

Measure the drive chain distance between a span of 41 pins from pin center to pin center with the chain held taut and any kinked joint straightened.

**SERVICE LIMIT: 511 mm (20.1 in)**

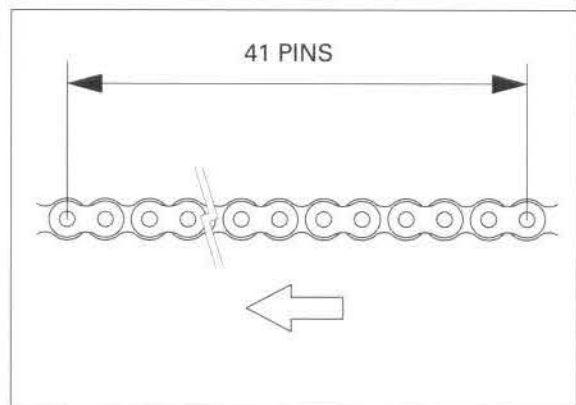

## SPROCKETS INSPECTION

Inspect the drive and driven sprocket teeth for wear or damage, replace if necessary.

Never use a new drive chain on worn sprockets.

Both chain and sprockets must be in good condition, or the new replacement chain will wear rapidly.

Check the attaching bolts and nuts on the drive and driven sprockets.

If any are loose, torque them.

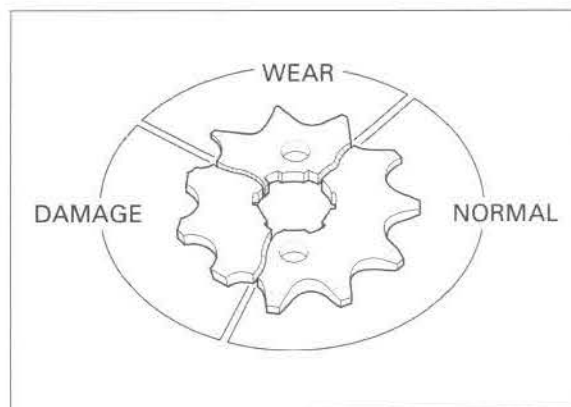

Install the drive chain onto the sprockets.

Install the master link and link plate.

Install the retaining clip with the open end opposite the direction of chain travel.

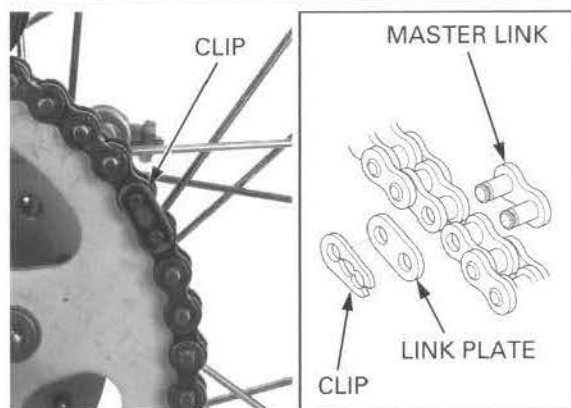

## DRIVE CHAIN SLIDER

### UPPER DRIVE CHAIN SLIDER

Check the upper drive chain slider for wear or damage.

Replace the drive chain slider if it is worn to the service limit or if it has been damaged.

**SERVICE LIMIT: 6.0 mm (0.23 in)**

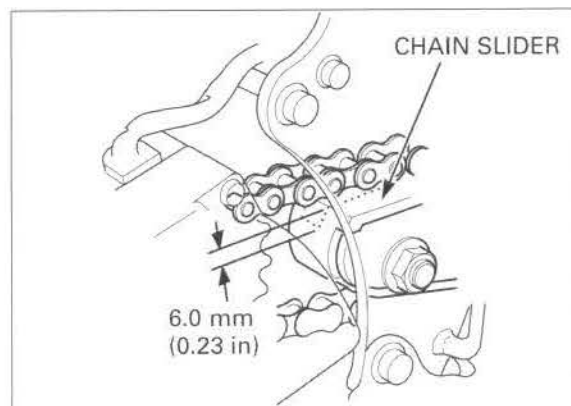

### LOWER DRIVE CHAIN SLIDER

Check the lower drive chain slider for wear or damage.

Replace the lower drive chain slider if it is worn to the wear limit or if it has been damaged.





## BRAKE SHOE WEAR

### FRONT BRAKE SHOES

Check the brake shoes and brake drum if the arrow on the indicator plate aligns with the "△" mark on the brake panel when the brake lever is applied.

Refer to page 12-15 for brake shoe replacement.

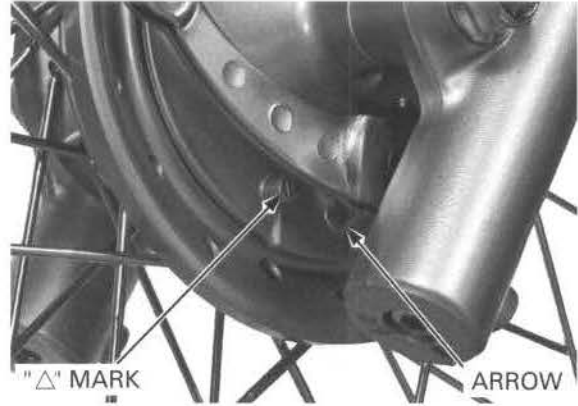

### REAR BRAKE SHOE

Check the brake shoes and brake drum if the arrow on the indicator plate aligns with the "△" mark on the brake panel when the brake pedal is applied.

Refer to page 13-12 for rear brake shoe replacement.

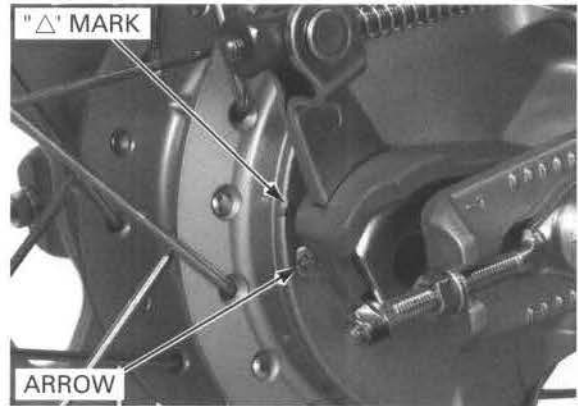

## BRAKE SYSTEM

### FRONT BRAKE

Measure the front brake lever free play at the tip of the lever.

**FREE PLAY:** 20 – 30 mm (3/4 – 1-1/4 in)

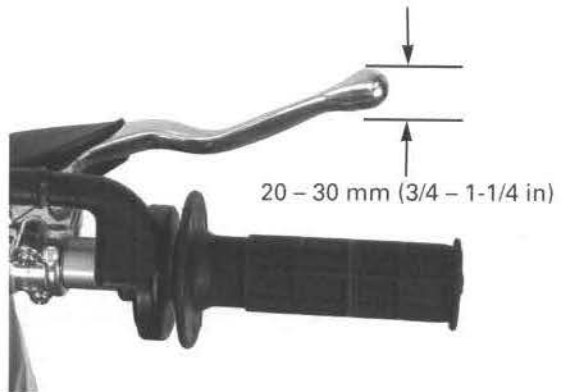

Minor adjustments can be made with the upper adjuster.

Loosen the lock nut and turn the adjuster until the free play is within specification.

After adjustment, tighten the lock nut.

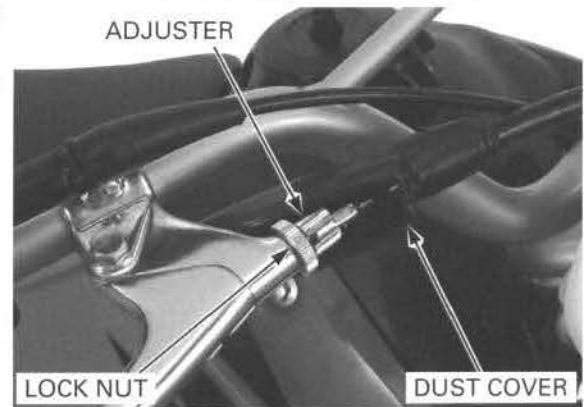

Major adjustments can be made with the lower adjuster on the brake panel.

Loosen the lock nut and turn the adjusting nut until the free play is within specification.

After adjustment, tighten the lock nut.



## REAR BRAKE

### Pedal Height

*Adjust the rear brake free play after adjusting the brake pedal height.*

Loosen the lock nut and adjust the brake pedal height by turning the adjusting bolt.

Retighten the lock nut.

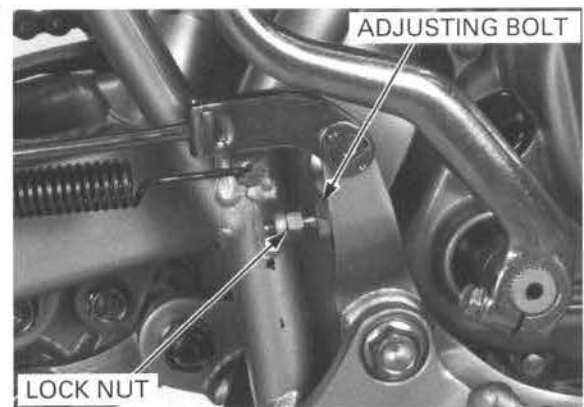

### Pedal Free Play

Check the brake pedal free play.

**FREE PLAY: 20 – 30 mm (3/4 – 1-1/4 in)**

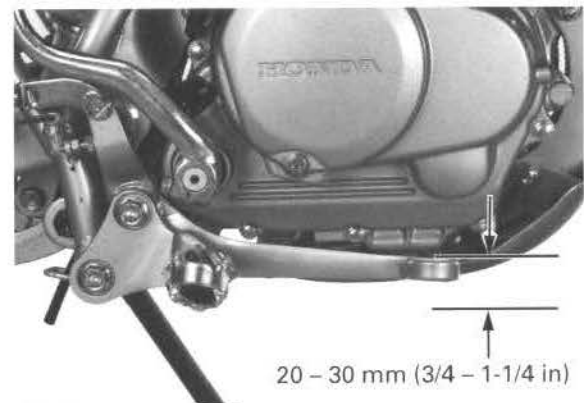

## MAINTENANCE

*Make sure the cut-out on the adjusting nut is seated on the brake arm pin after making the final free play adjustment.*

Adjust the brake pedal free play by turning the adjusting nut.

ADJUSTING NUT

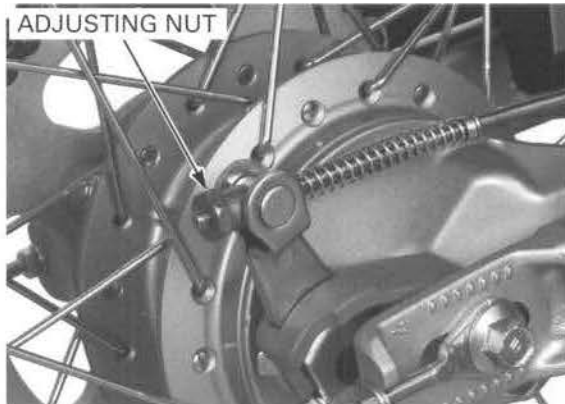

## CLUTCH SYSTEM

Measure the clutch free play at the tip of the clutch lever.

**FREE PLAY: 10 – 20 mm (3/8 – 3/4 in)**

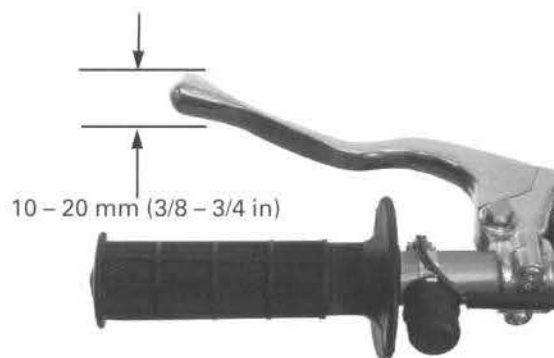

Minor adjustments can be made with the upper adjuster.

Loosen the lock nut, turn the adjuster and retighten the lock nut.

Check the clutch operation.

ADJUSTER

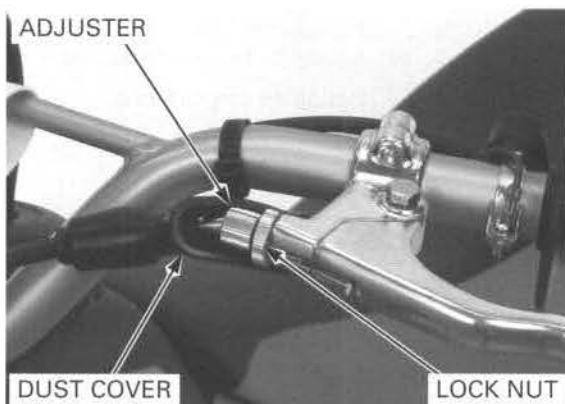

Major adjustment can be made with the lower adjuster.

Loosen the lower adjuster lock nut and turn the adjuster all the way in.

LOCK NUT

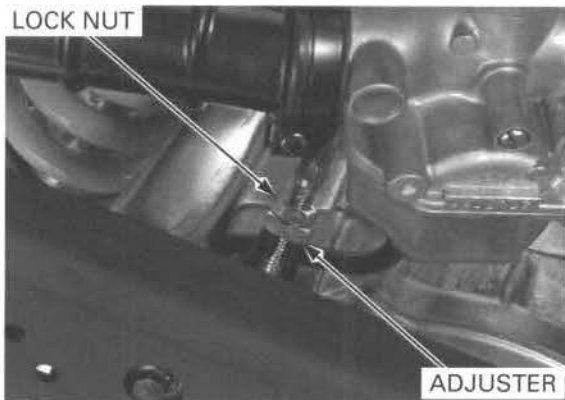

Loosen the adjusting screw lock nut on the right crankcase. Turn the adjusting screw counterclockwise until resistance is felt. Then turn the screw clockwise 1/8–1/4 of a turn. Hold the adjusting screw and tighten the lock nut.

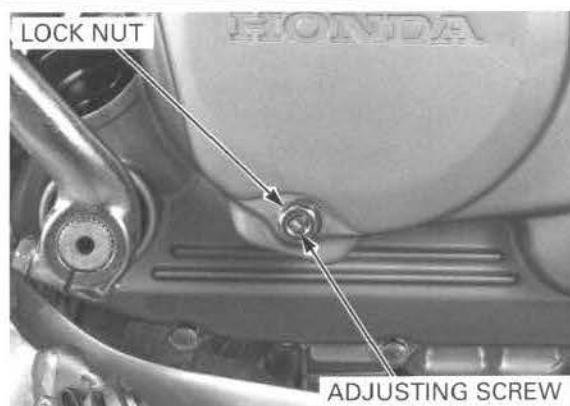

Turn the lower adjuster out until the free play at the lever end is 10 – 20 mm (3/8 – 3/4 in).

Tighten the lock nut.

Then turn the upper adjuster to obtain the specified free play (page 3-22).

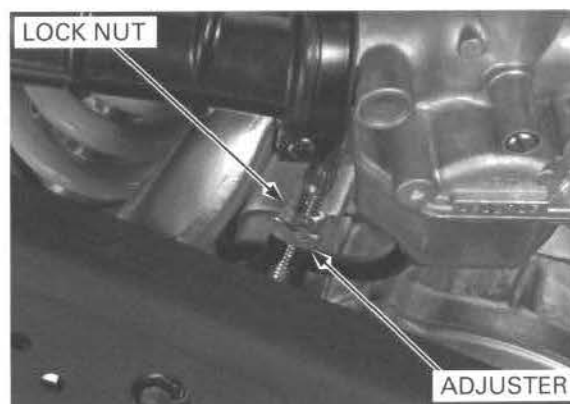

## SIDE STAND

Support the motorcycle on a level surface.

Check the side stand spring for damage or loss of tension.

Check the side stand assembly for freedom of movement and lubricate the side stand pivot if necessary.

Check that the side stand pivot bolt is tightened to the correct torque value.

Tighten the pivot bolt to the specified torque.

**TORQUE: 10 N·m (1.0 kgf·m, 7 lbf·ft)**

Loosen the pivot bolt 1/8 to 1/4 turns, then tighten the side stand pivot lock nut to the specified torque.

**TORQUE: 39 N·m (4.0 kgf·m, 29 lbf·ft)**

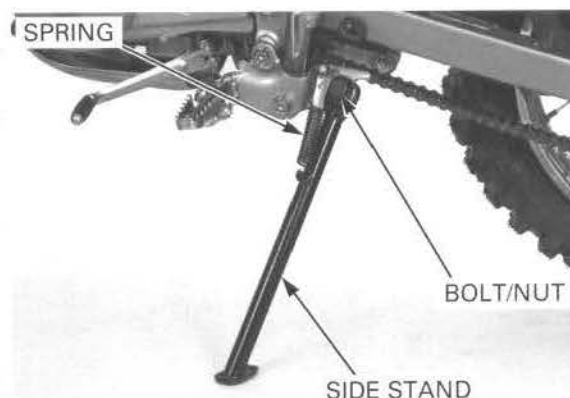

## SUSPENSION

### FRONT SUSPENSION INSPECTION

Check the action of the front suspension by operating the front brake and compressing the forks several times.

Check the entire fork assembly for signs of leaks, damage or loose fasteners.

Replace damaged components which cannot be repaired.

Tighten all nuts and bolts.

Refer to page 12-18 for fork service.



### REAR SUSPENSION INSPECTION

Support the motorcycle securely and raise the rear wheel off the ground by placing a work stand or a box under the engine.

Check for worn swingarm bushings by grabbing the rear end of the swingarm and attempting to move the swingarm side to side.

Replace the bushings if any looseness is noted.

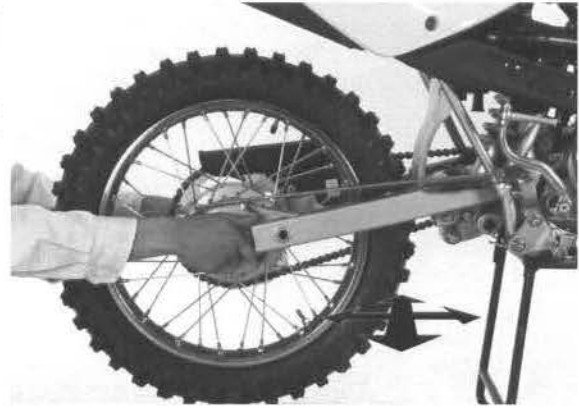

Check the action of the shock absorber by compressing it several times.

Check the entire shock absorber assembly for signs of leaks, damage or loose fasteners.

Replace damaged components which cannot be repaired.

Tighten all nuts and bolts.

Refer to page 13-18 for shock absorber service.



## SPARK ARRESTER

### INSPECTION/CLEANING

Remove the three SH bolts, spark arrester and gasket from the muffler.

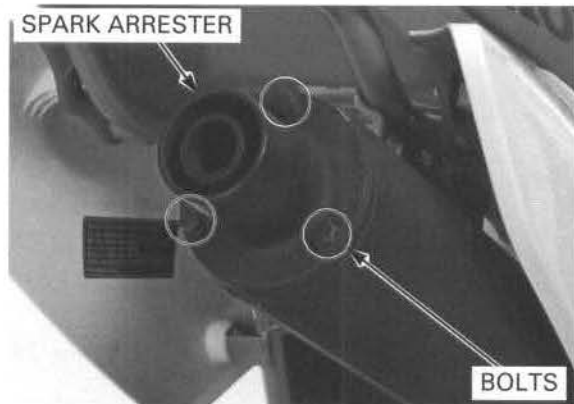

Check the screen mesh, replace if necessary.

Use a soft brush to remove carbon deposits from the spark arrester screen.

Be careful not to avoid damaging the spark arrester screen.

The spark arrester must be free of breaks and holes, replace if necessary.

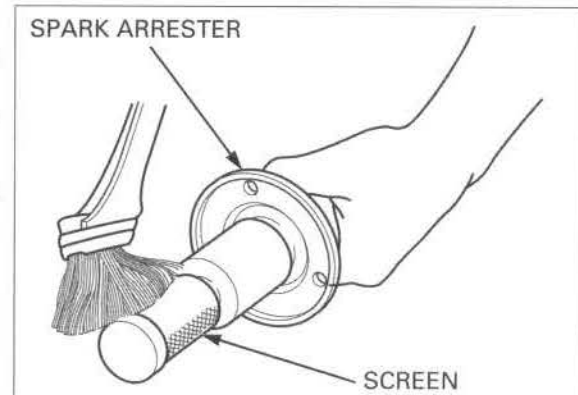

Install the new gasket to the spark arrester.

Install the spark arrester and tighten the three bolts securely.

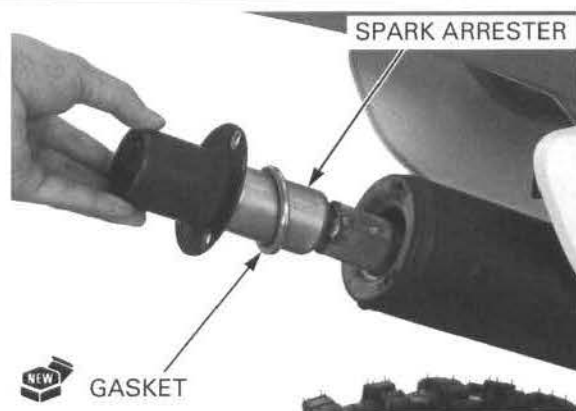

## NUTS, BOLTS, FASTENERS

Check that all chassis nuts and bolts are tightened to their correct torque values (page 1-13).

Check that all safety clips, hose clamps and cable stays are in place and properly secured.

## WHEELS/TIRES

### RECOMMENDED TIRE PRESSURE AND TIRE SIZE:

Tire pressure kpa (kgf/cm <sup>2</sup> , psi)		Front	100 (1.0 14)
		Rear	100 (1.0 14)
Tire size	CRF100F	Front	70/100-19 M/C 42M
		Rear	90/100-16 M/C 51M
	CRF80F	Front	2.50-16 4PR
		Rear	3.60-14 4PR
Tire brand	CRF100F	Front	Cheng shin
		Rear	Cheng shin
	CRF80F	Front	IRC
		Rear	IRC

Check the tires for cuts, embedded nails, or other damage.

Check the front and rear wheels for trueness (refer to Sections 12 and 13).

Check the cold tire pressure.

*Tire pressure should be checked when the tires are cold.*



Maintenance of spoke tension and wheel trueness are critical to safe motorcycle operation. During the first 150 km (100 miles), spoke will loosen more rapidly due to initial seating of parts. Excessively loose spokes may result in high speed instability and possible loss of control.

Inspect the wheel rims and spokes for damage.

Tighten any loose spokes to the specified torque.

### TOOL:

Spoke wrench, 4.5 x 5.1 mm

07701-0020200 or equivalent commercially available in U.S.A.

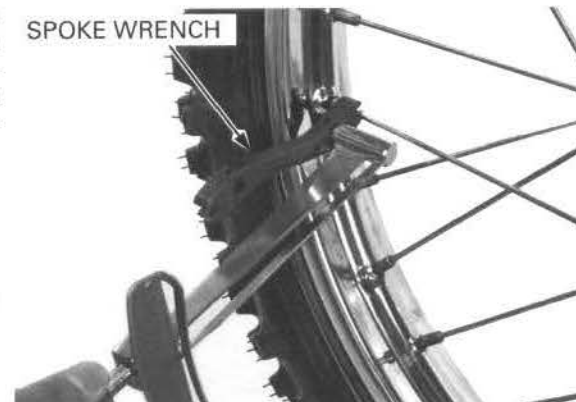

**TORQUE: 3 N·m (0.3 kgf·m, 2 lbf·ft)**

## MAINTENANCE

Tighten the rim lock to the specified torque.

**TORQUE: 12 N·m (1.2 kgf·m, 9 lbf·ft)**

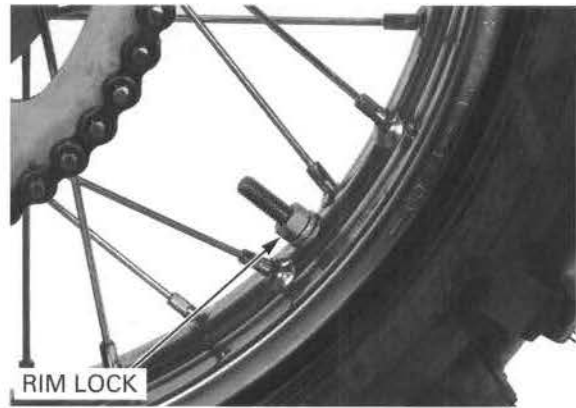

## STEERING HEAD BEARINGS

Raise the front wheel off the ground by placing a work stand or box under the engine.

*Check that the control cables do not interfere with handlebar rotation.*

Check that the handlebar moves freely from side to side.

If the handlebar moves unevenly, binds, or has vertical movement, inspect the steering head bearings (page 12-26).





# 4. LUBRICATION SYSTEM

---

LUBRICATION SYSTEM DIAGRAM .....	4-2	CYLINDER HEAD OIL CHECK BOLT .....	4-5
SERVICE INFORMATION .....	4-3	OIL PUMP .....	4-5
TROUBLESHOOTING .....	4-4		

LUBRICATION SYSTEM DIAGRAM

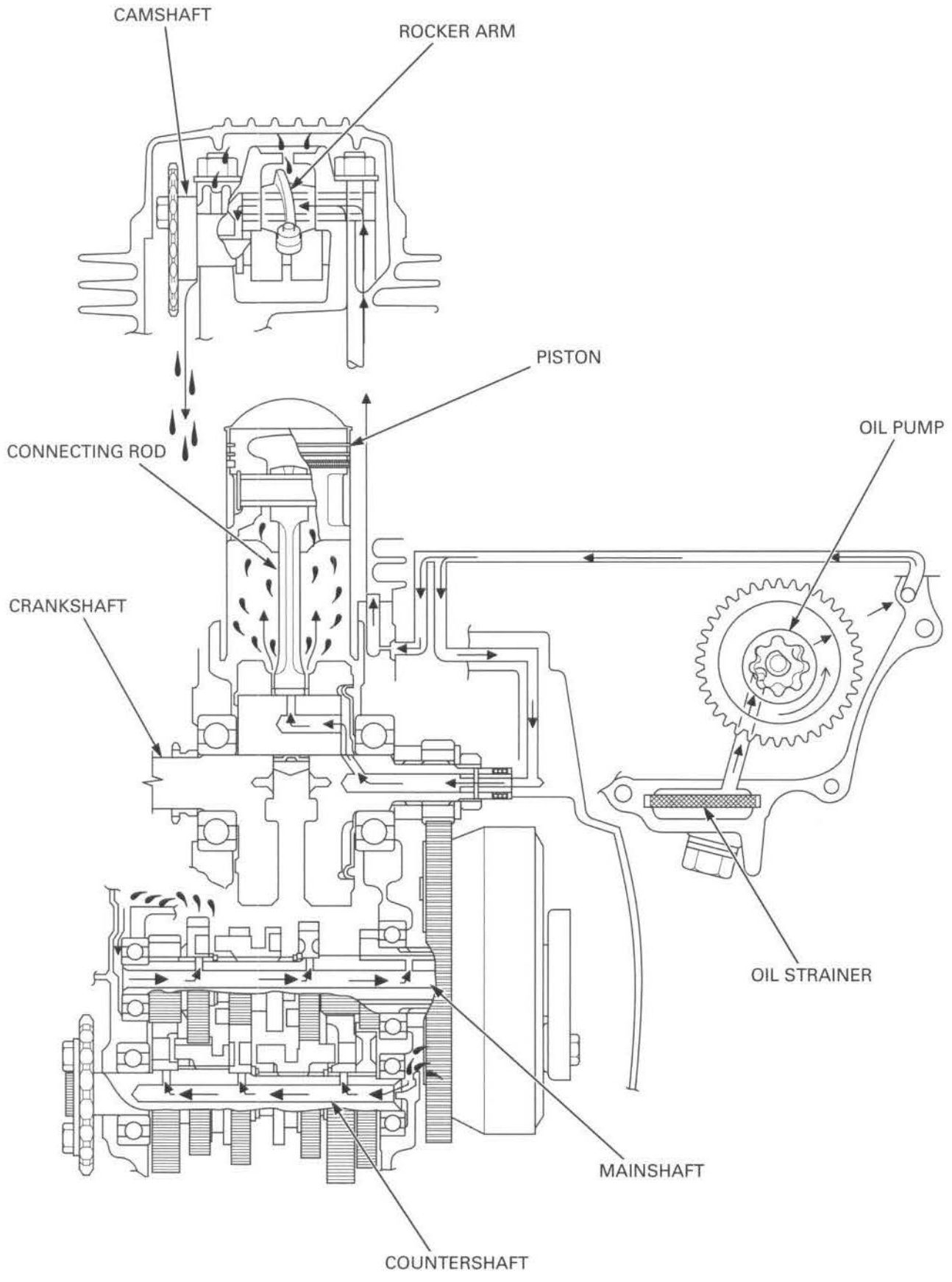

## SERVICE INFORMATION

### GENERAL

#### ⚠ CAUTION

Used engine oil may cause skin cancer if repeatedly left in contact with the skin for prolonged periods. Although this is unlikely unless you handle used oil on a daily basis, it is still advisable to thoroughly wash your hands with soap and water as soon as possible after handling used oil.

- The oil pump can be serviced with the engine installed in the frame.
- The service procedures in this section must be performed with the engine oil drained.
- When removing and installing the oil pump, use care not to allow dust or dirt to enter the engine.
- If any portion of the oil pump is worn beyond the specified service limits, replace the oil pump as an assembly.
- After the oil pump has been installed, check that there are no oil leaks and that oil pressure is correct.

### SPECIFICATIONS

Unit: mm (in)

ITEM		STANDARD	SERVICE LIMIT
Engine oil capacity	CRF100F	At draining	0.9 liter (1.0 US qt, 0.8 Imp qt)
		At disassembly	1.1 liter (1.2 US qt, 1.0 Imp qt)
	CRF80F	At draining	0.9 liter (1.0 US qt, 0.8 Imp qt)
		At disassembly	1.1 liter (1.2 US qt, 1.0 Imp qt)
Recommended engine oil		Pro Honda GN4 4-stroke oil (U.S.A and Canada) or equivalent motor oil API service classification: SG or higher JASO T 903 standard: MA Viscosity: SAE 10W-30	-
Oil pump rotor	Tip clearance	0.15 (0.006)	0.20 (0.008)
	Body clearance	0.15 – 0.21 (0.006 – 0.008)	0.40 (0.016)
	Side clearance	0.02 – 0.07 (0.001 – 0.003)	0.25 (0.010)

### TORQUE VALUES

Oil pump plate screw

3 N·m (0.3 kgf·m, 2 lbf·ft)

### TROUBLESHOOTING

#### Engine oil level too low, high oil consumption

- Oil consumption
- External oil leaks
- Worn piston rings
- Improperly installed piston rings
- Worn cylinder
- Worn valve guide
- Worn valve stem seals
- Faulty head gasket

#### Low oil pressure

- Oil level low
- Clogged oil strainer
- Internal oil leak
- Incorrect oil being used
- Oil not change often enough
- Oil pump drive gear broken

#### No oil pressure

- Oil level too low
- Damaged oil pump
- Oil pump drive gear broken
- Internal oil leak

#### High oil pressure

- Clogged oil strainer.
- Incorrect oil being used

#### Engine oil contamination

- Oil not changed often enough
- Faulty head gasket
- Worn piston rings

#### Oil emulsification

- Entry of water

## CYLINDER HEAD OIL CHECK BOLT

Start the engine and let it idle.

*Do not remove the oil check bolt when the engine is running.*

Loosen, but do not remove, the cylinder head oil check bolt and make sure oil comes out of the oil bolt hole.

If do not flow the engine oil from the oil check bolt hole, inspect the related oil passage clogging.

Retighten the oil check bolt and check for no oil leaks.

If engine oil leaks from the oil check bolt hole, stop the engine and replace the sealing washer with a new one.

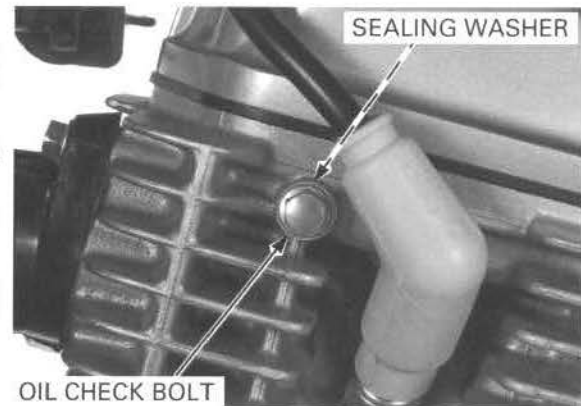

## OIL PUMP

### REMOVAL

Drain the engine oil (page 3-14).

Remove the following:

- Right crankcase cover (page 9-5)
- Oil through

Turn the crankshaft and align the holes on the oil pump drive gear with oil pump mounting screws (or bolts).

*CRF100F:* Remove the two screws, oil pump and O-rings.

*CRF80F:* Remove the two bolts, oil pump and O-rings.

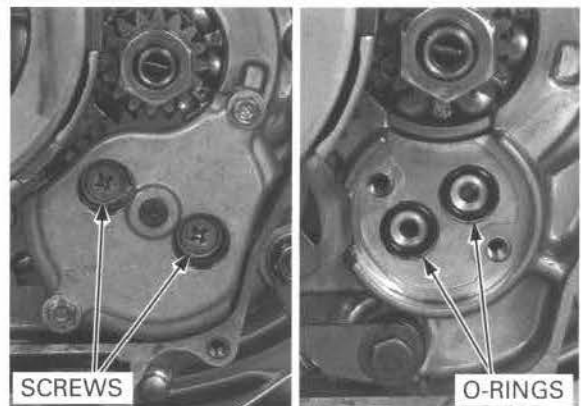

### INSPECTION

Remove the two screws and oil pump plate.

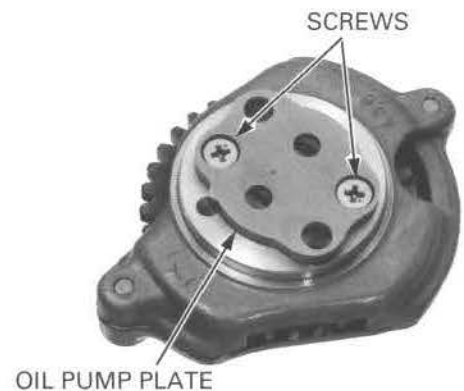

## LUBRICATION SYSTEM

*If any portion of the oil pump is worn beyond the specified service limits, replace the oil pump as an assembly.*

Temporarily install the outer and inner rotors into the oil pump body.

Install the oil pumps shaft.

Measure the tip clearance between the inner and outer rotors.

**SERVICE LIMIT: 0.20 mm (0.008 in)**

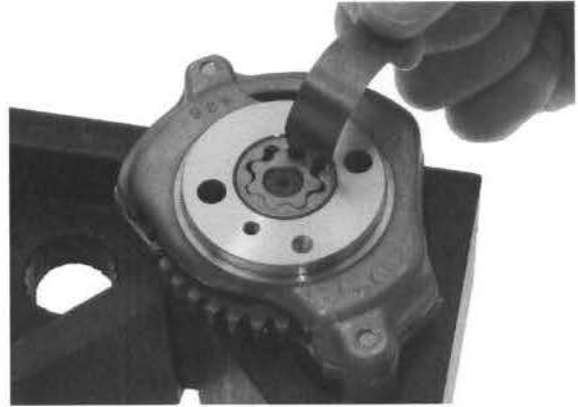

Measure the pump body clearance between the outer rotor and pump body.

**SERVICE LIMIT: 0.40 mm (0.016 in)**



Measure the side clearance using a straight edge and feeler gauge.

**SERVICE LIMIT: 0.25 mm (0.010 in)**



## DISASSEMBLY

Remove the two screws and oil pump plate.

Remove the gasket.

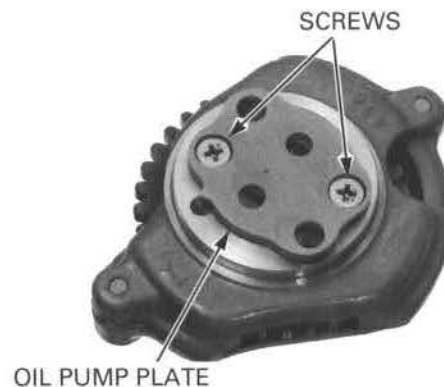

Remove the inner rotor and outer rotor.

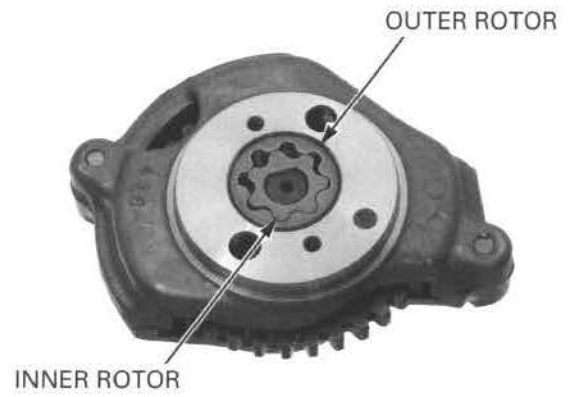

Remove the two bolts and oil pump gear cover.

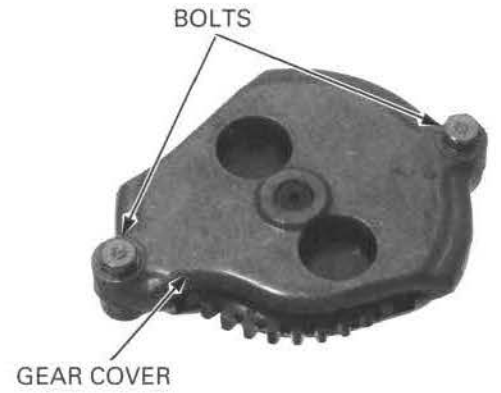

Remove the oil pump drive shaft and drive gear.  
Check the drive gear and shaft for wear or damage.

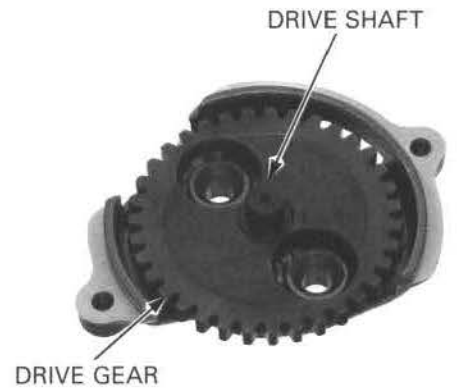



ASSEMBLY

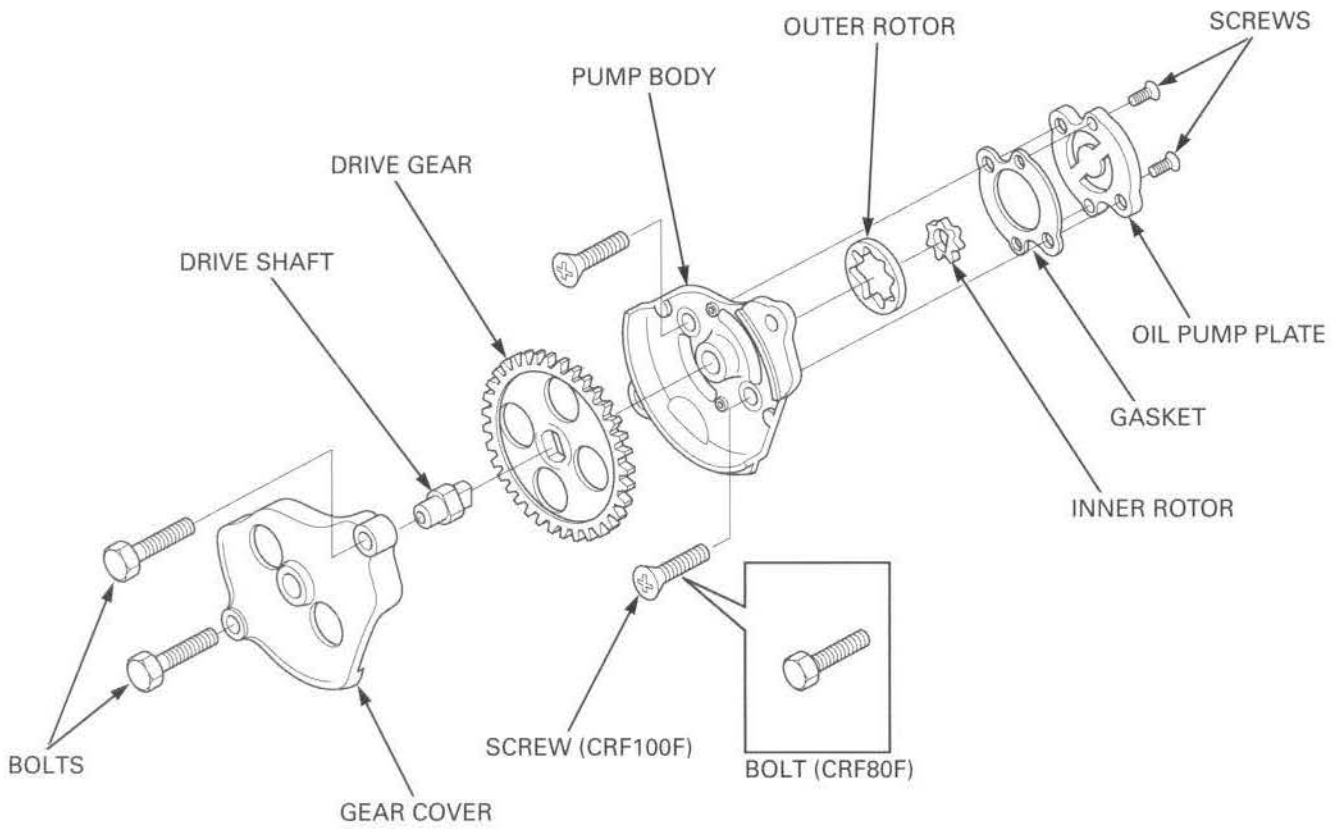

Install the oil pump drive shaft and drive gear in the body by aligning the cut-outs of the oil pump drive shaft and gear.

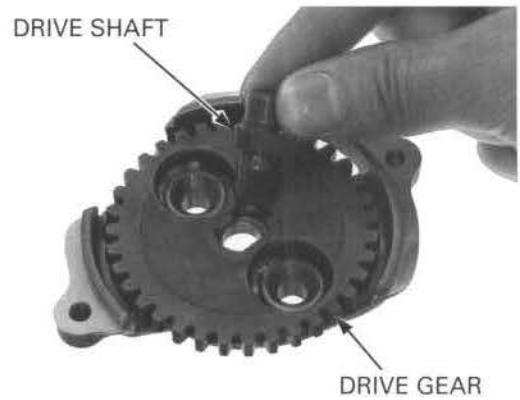

Install the oil pump gear cover and tighten the bolts securely.



Install the outer rotor and inner rotor.  
Install a new gasket and oil pump plate.

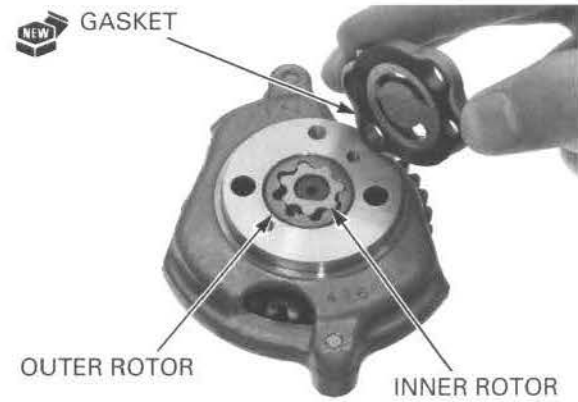

Install the oil pump plate by aligning the boss on the plate with the cutout in the pump body.

Tighten the two oil pump plate screws to the specified torque.

**TORQUE: 3 N·m (0.3 kgf·m, 2 lbf·ft)**

Check the oil pump operation by rotating the pump gear by hand.

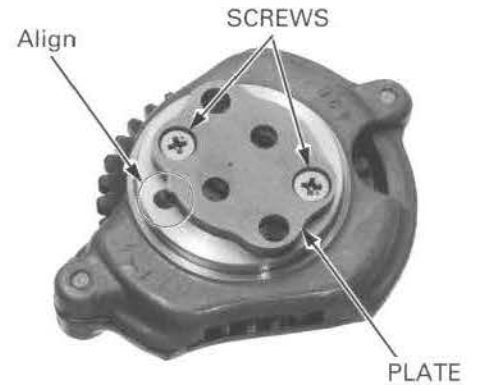

### INSTALLATION

Apply oil to new O-rings, then install them onto the right crankcase.

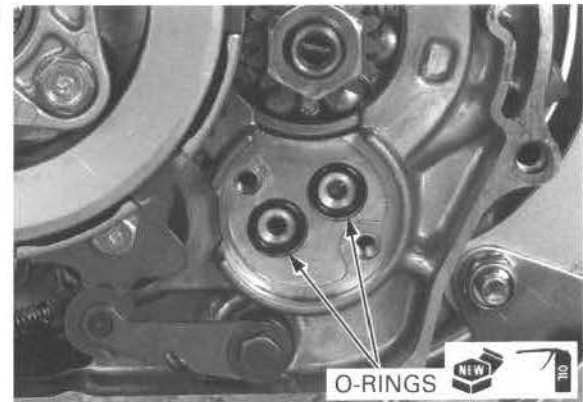

Turn the crankshaft and align the holes on the oil pump drive gear with oil pump mounting screws (or bolts).

*CRF100F:* Tighten the two screws.

*CRF80F:* Tighten the two bolts.



## LUBRICATION SYSTEM

Install the oil through align the cutout to the drive pin.

Install the right crankcase cover (page 9-14).

After installation, fill the crankcase with recommended oil (page 3-13) and check that there are no oil leak.

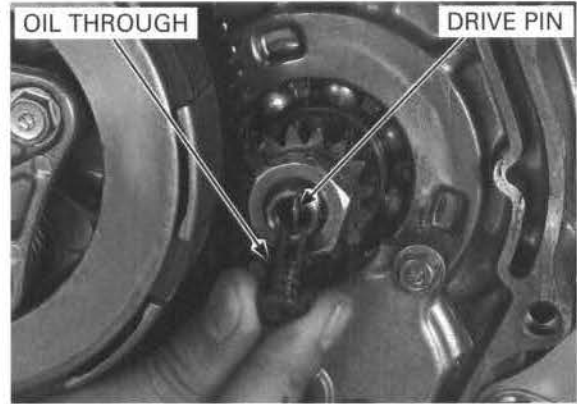

COMPONENT LOCATION .....	5-2	CARBURETOR ASSEMBLY .....	5-12
SERVICE INFORMATION .....	5-3	CARBURETOR INSTALLATION .....	5-15
TROUBLESHOOTING .....	5-5	PILOT SCREW ADJUSTMENT (CRF100F) .....	5-18
AIR CLEANER HOUSING .....	5-6	AIR SCREW ADJUSTMENT (CRF80F) .....	5-19
CARBURETOR REMOVAL .....	5-6	HIGH ALTITUDE ADJUSTMENT .....	5-20
CARBURETOR DISASSEMBLY .....	5-8		

COMPONENT LOCATION

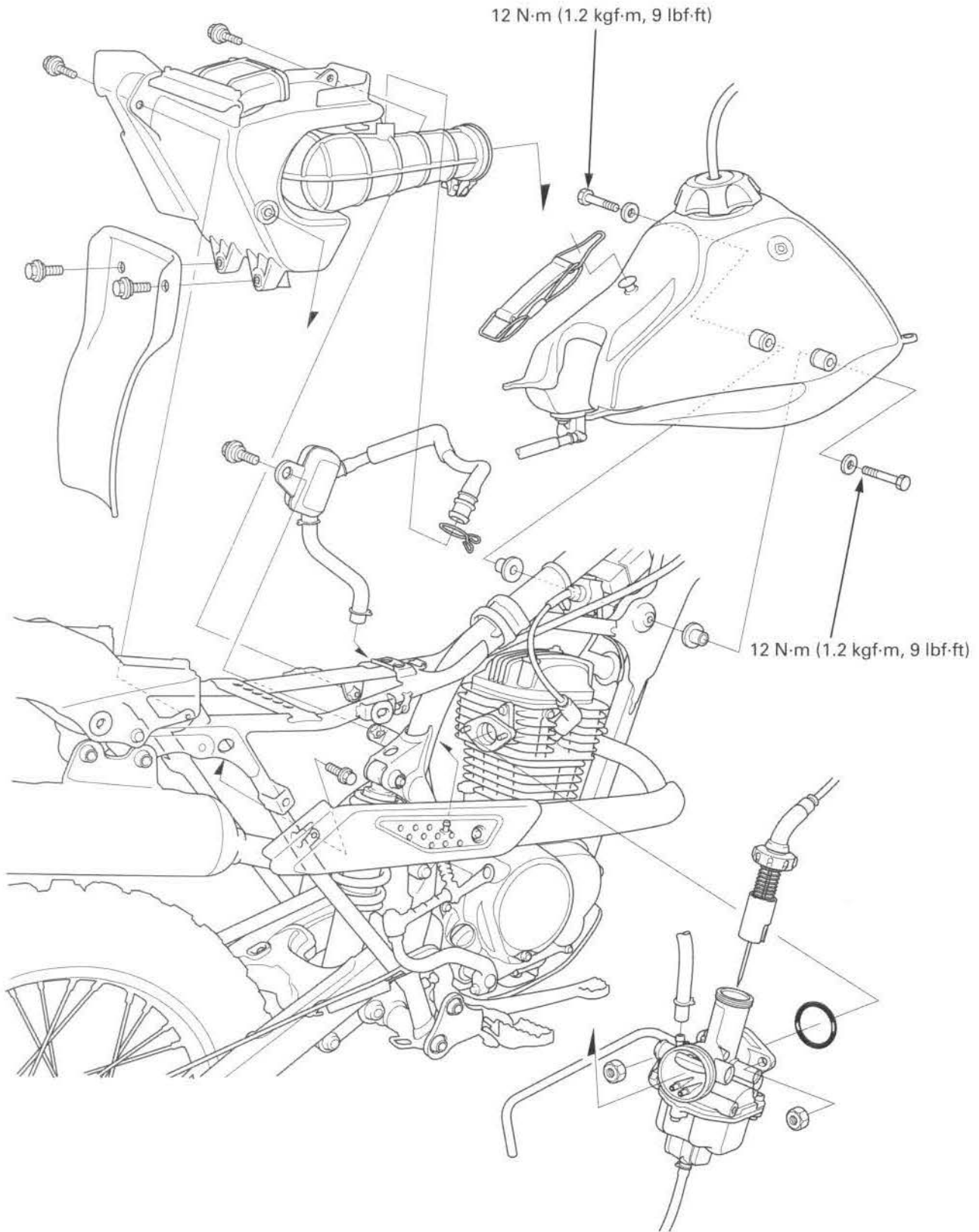

## SERVICE INFORMATION

### GENERAL

- Bending or twisting the control cable will impair smooth operation and could cause the cable to stick or bind, resulting in loss of vehicle control.
- Work in a well ventilated area. Smoking or allowing flames or sparks in the work area or where gasoline is stored can cause a fire or explosion.
- When disassembling fuel system parts, note the locations of the O-rings. Replace them with new ones on reassembly.
- Before removing the carburetor, place an approved gasoline container under the carburetor drain hose, loosen the drain screw and drain the carburetor.
- After removing the carburetor, wrap the intake port of the engine with a shop towel or cover it with pieces of tape to prevent any foreign material from dropping into the engine.
- Refer to page 2-4 for fuel tank removal and installation.
- If the vehicle is to be stored for more than one month, drain the float bowl. fuel left in the float bowl may cause clogged jets, resulting in hard starting or poor driveability.

### SPECIFICATIONS (CRF100F)

ITEM	SPECIFICATIONS
Carburetor identification number ('04 and '05)	PDC3L
Carburetor identification number ('06 and '07)	PDCBF
Carburetor identification number (After '07)	PDCBL
Carburetor type	Piston valve
Main jet	#98
Main jet (High altitude setting)	#92
Slow jet	#35 x #35
Jet needle clip position ('04 and '05)	3rd groove from top
Pilot screw opening	See page 5-18
Float level	12.5 mm (0.49 in)
Engine idle speed	1,400 ± 100 rpm
Throttle grip free play	2 – 6 mm (1/12 – 1/4 in)

### SPECIFICATIONS (CRF80F)

ITEM	SPECIFICATIONS
Carburetor identification number ('04 and '05)	PC20M
Carburetor identification number ('06 and '07)	PC20P
Carburetor identification number (After '07)	PC20Q
Carburetor type	Piston valve
Main jet	#95
Main jet (High altitude setting)	#90
Slow jet	#35
Jet needle clip position ('04 and '05)	3rd groove from top
Air screw opening	See page 5-19
Float level	21.5 mm (0.85 in)
Engine idle speed	1,500 ± 100 rpm
Throttle grip free play	2 – 6 mm (1/12 – 1/4 in)

### TORQUE VALUES

Float chamber screw	2.1 N·m (0.2 kgf·m, 1.4 lbf·ft)	
Carburetor drain screw (CRF100F)	1.5 N·m (0.15 kgf·m, 1.1 lbf·ft)	
Carburetor drain screw (CRF80F)	2.5 N·m (0.25 kgf·m, 1.8 lbf·ft)	
Choke lever set plate screw	3.4 N·m (0.35 kgf·m, 2.5 lbf·ft)	CRF100F only

# FUEL SYSTEM

## TOOLS

Carburetor float level gauge  
07401-0010000

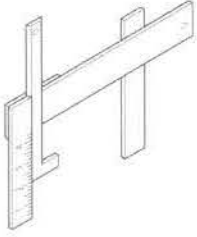

Pilot screw wrench (D type)  
07KMA-MS60101

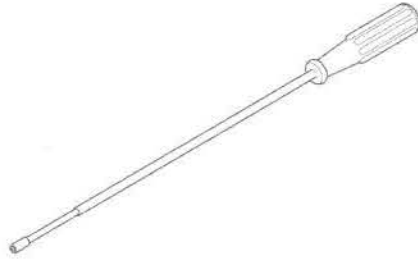

or 07KMA-MN9A100 (U.S.A. only)

Pilot screw wrench guide  
07PMA-MZ20110

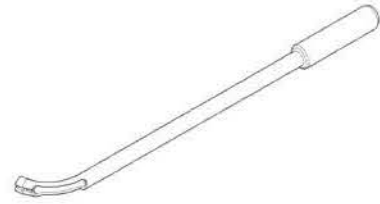



## TROUBLESHOOTING

### Engine cranks but won't start

- No fuel to carburetor
  - Fuel strainer clogged
  - Fuel hose clogged
  - Float level misadjusted
  - Fuel tank breather hose clogged
- Too much fuel getting to the engine
  - Flooded carburetor
  - Clogged air cleaner
- Fuel contaminated/deteriorated
- No spark at plug (ignition system faulty)
- Intake air leak
- Improper choke operation
- Improper throttle operation

### Engine idles roughly, runs poorly or stalls

- Fuel line restricted
- Improper choke operation
- Ignition malfunction
- Fuel contaminated/deteriorated
- Intake air leak
- Incorrect idle speed
- Incorrect float level
- Pilot or air screw miss adjustment
- Low cylinder compression
- Rich mixture
- Lean mixture
- Clogged carburetor

### Backfiring or misfiring during acceleration

- Ignition system faulty
- Fuel mixture too lean

### Afterburn when engine braking is used

- Lean mixture in slow circuit

### Poor performance (driveability) and poor fuel economy

- Fuel system clogged
- Ignition system faulty
- Air cleaner clogged

### Lean mixture

- Clogged fuel jets
- Faulty float valve
- Float level too low
- Blocked fuel fill cap air vent hose
- Clogged fuel strainer screen
- Restricted fuel line
- Clogged carburetor air vent hose
- Intake air leak
- Throttle valve faulty

### Rich mixture

- Clogged air cleaner
- Worn jet needle or needle jet
- Faulty float valve
- Float level too high
- Choke lever in CLOSE position
- Air jets clogged
- Flooded carburetor

### AIR CLEANER HOUSING

#### REMOVAL/INSTALLATION

*Refer to page 3-10 for air cleaner element service.*

Remove the following:

- Side cover (page 2-3)
- mud guard (page 2-6)

Disconnect the crankcase breather hose from the connecting tube.

Disconnect the air vent hose from the air cleaner housing groove.

Loosen the connecting tube band screw.

Remove the air cleaner housing mounting bolt.

Remove the two air cleaner housing mounting bolts, then remove the air cleaner housing from the left side of the frame.

*Make sure the carburetor connecting tube band is tightened securely.*

Install the air cleaner housing in the reverse order of removal.

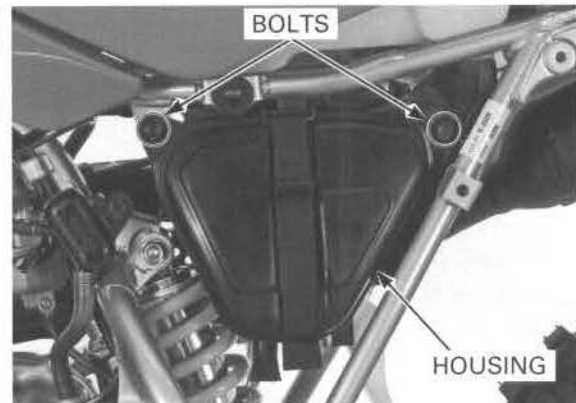
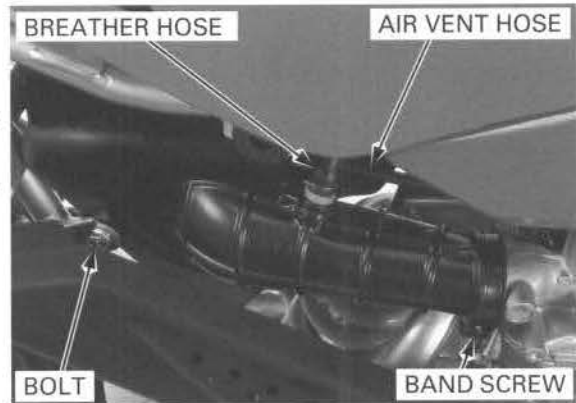

### CARBURETOR REMOVAL

#### THROTTLE VALVE

Loosen the carburetor top and pull the throttle valve out.

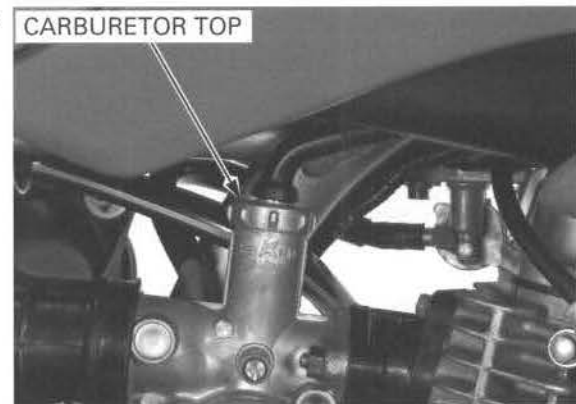

Remove the throttle cable from the throttle valve while compressing the throttle valve spring.

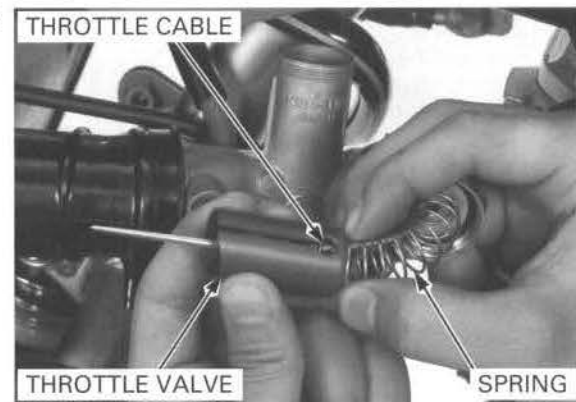

Remove the jet needle retainer and jet needle.

JET NEEDLE

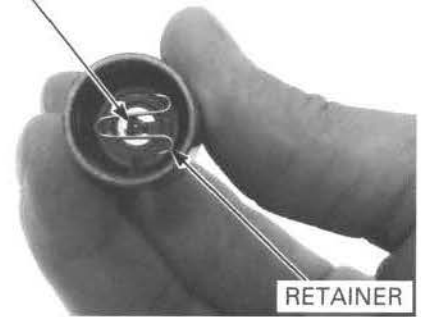

Check the throttle valve and jet needle for scratches, wear or damage.

THROTTLE VALVE



RETAINER



JET NEEDLE

### CARBURETOR BODY

Turn the fuel valve OFF.

Remove the throttle valve (page 5-6).

Place an approved gasoline container under the drain hose and loosen the drain screw to drain the fuel.

Disconnect the fuel hose from the carburetor.

FUEL HOSE



Remove the air vent hose from the air cleaner housing groove.

AIR VENT HOSE

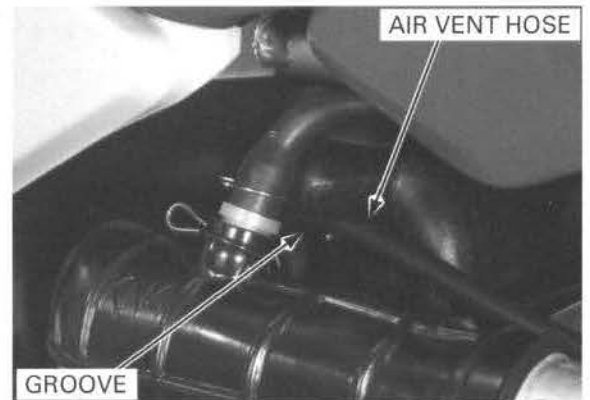

GROOVE

## FUEL SYSTEM

Loosen the connecting tube band screw.

Remove the carburetor mounting nuts, then remove the carburetor to the right.

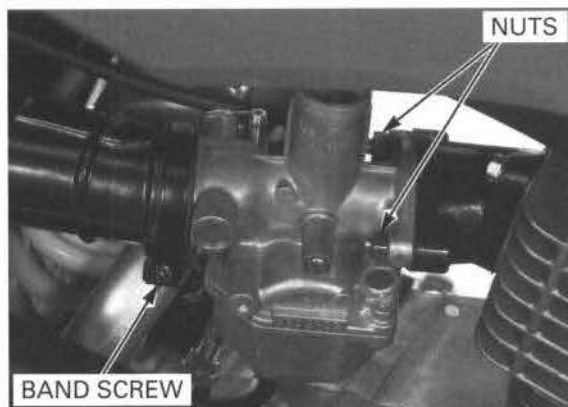

Remove the O-ring from the carburetor body.

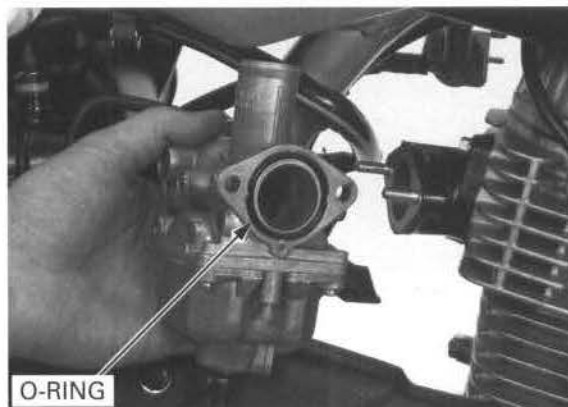

## CARBURETOR DISASSEMBLY

Disconnect the air vent hose and drain hose.

*CRF100F:* Remove the screw, set plate, choke lever and washer.

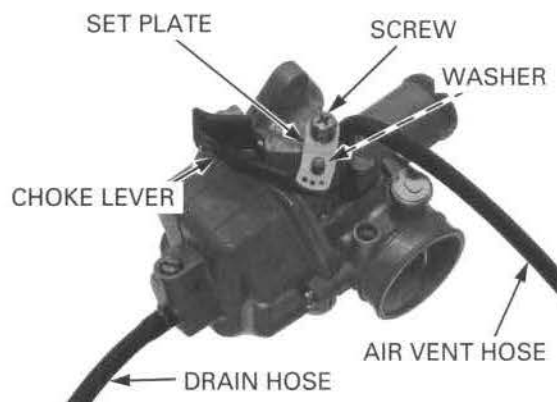

*CRF100F:* Remove the three screws and float chamber.

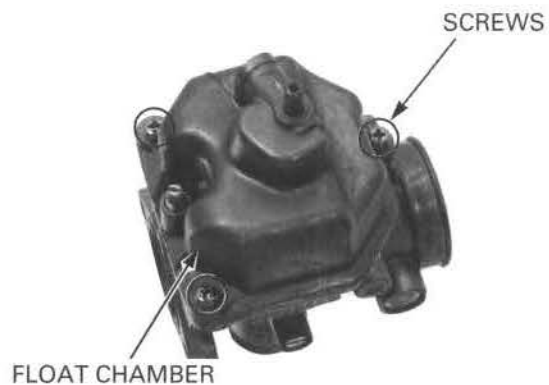

CRF80F: Remove the two screws and float chamber.

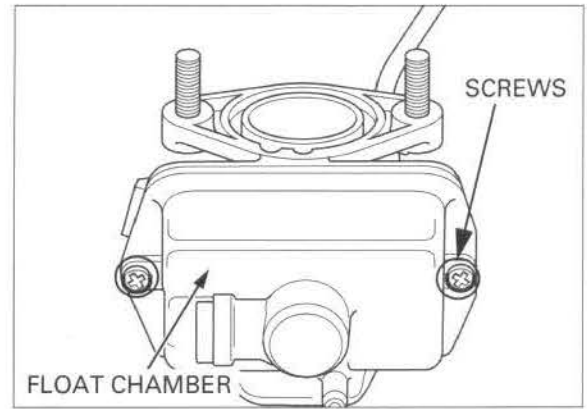

Remove the O-ring from the float chamber.

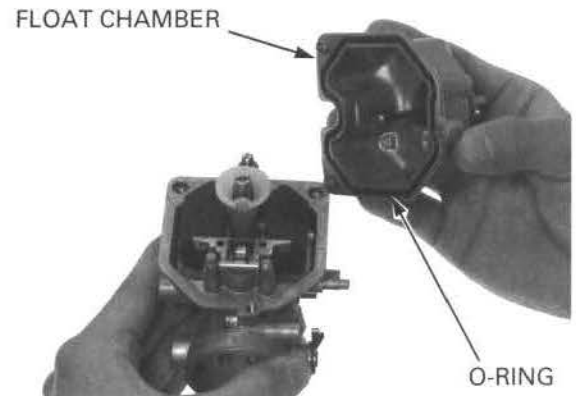

Remove the float pin, float and float valve.  
Inspect the float for deformation or damage.

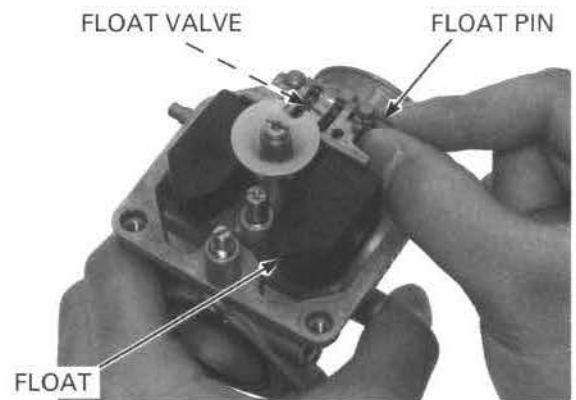

Inspect the float valve seat for scores, scratches, clogging and damage.

Check the tip of the float valve where it contacts the valve seat for stepped wear or contamination.

Replace the valve if the tip is worn or contaminated.

Check the operation of the float valve.

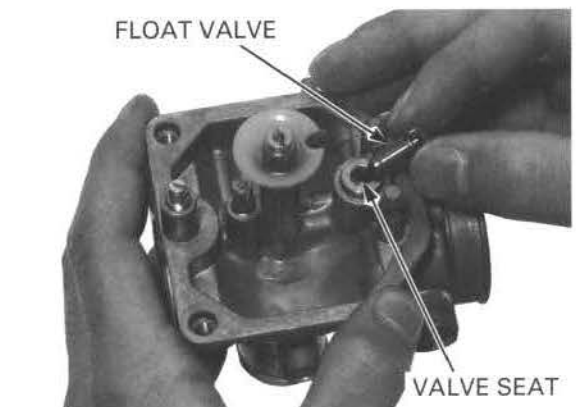

## FUEL SYSTEM

### CRF100F

Remove the following:

- Jet holder
- Main jet
- Needle jet holder
- Needle jet
- Slow jet
- Throttle stop screw/spring

*Damage to the pilot screw seat will occur if the pilot screw is tightened against the seat.*

Turn the pilot screw in and record the number of turns it takes before it seats lightly.

Remove the pilot screw, spring, washer and O-ring.

After '05:

#### TOOLS:

**Pilot screw wrench (D type)** 07KMA-MS60101 or  
07KMA-MN9A100  
(U.S.A. only)

**Pilot screw wrench guide** 07PMA-MZ20110

Inspect each jet for wear or damage and replace if necessary.

Clean each jet with non-flammable or high flash point solvent and blow open with compressed air.

Check the pilot screw for stepped wear or damage.

Check the spring for damage.

Replace these parts if necessary.

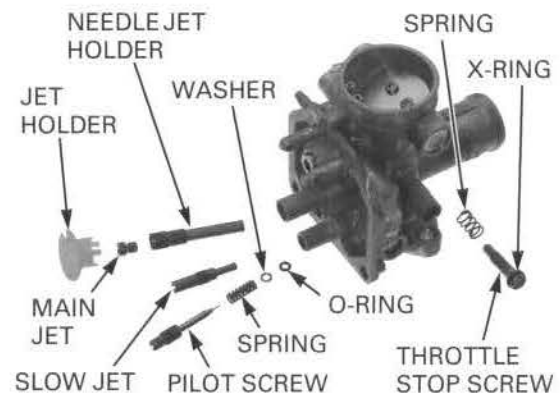
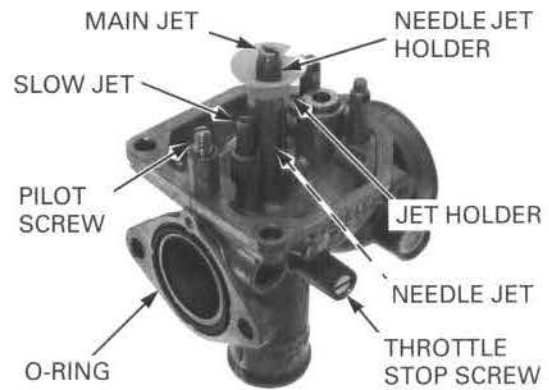

### CRF80F

Remove the following:

- Jet holder
- Main jet
- Needle jet holder
- Needle jet
- Slow jet
- Throttle stop screw/spring

*Damage to the air screw seat will occur if the air screw is tightened against the seat.*

Turn the air screw in and record the number of turns it takes before it seats lightly.

Remove the air screw and spring.

After '05:

#### TOOLS:

**Pilot screw wrench (D type)** 07KMA-MS60101 or  
07KMA-MN9A100  
(U.S.A. only)

**Pilot screw wrench guide** 07PMA-MZ20110

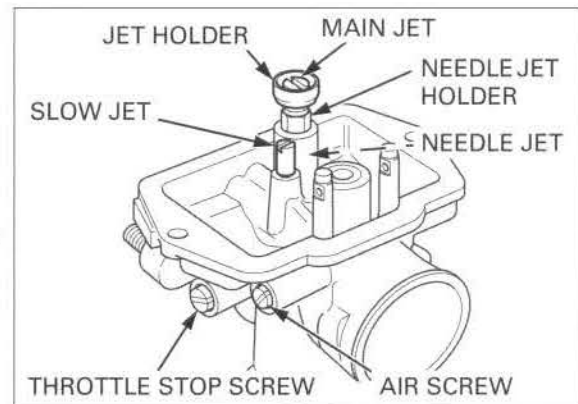

Inspect each jet for wear or damage and replace if necessary.

Clean each jet with non-flammable or high flash point solvent and blow open with compressed air.

Check the air screw for stepped wear or damage.

Check the spring for damage.

Replace these parts if necessary.

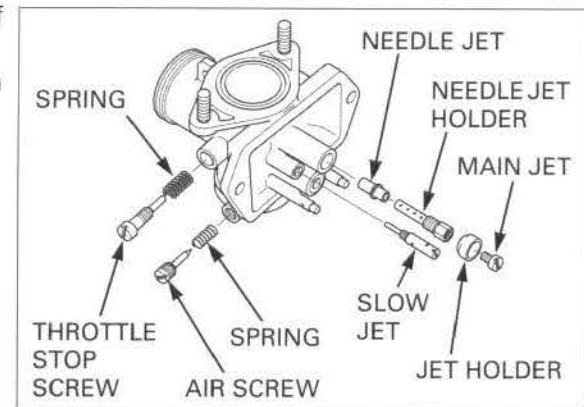



# FUEL SYSTEM

## CARBURETOR ASSEMBLY

CRF100F:

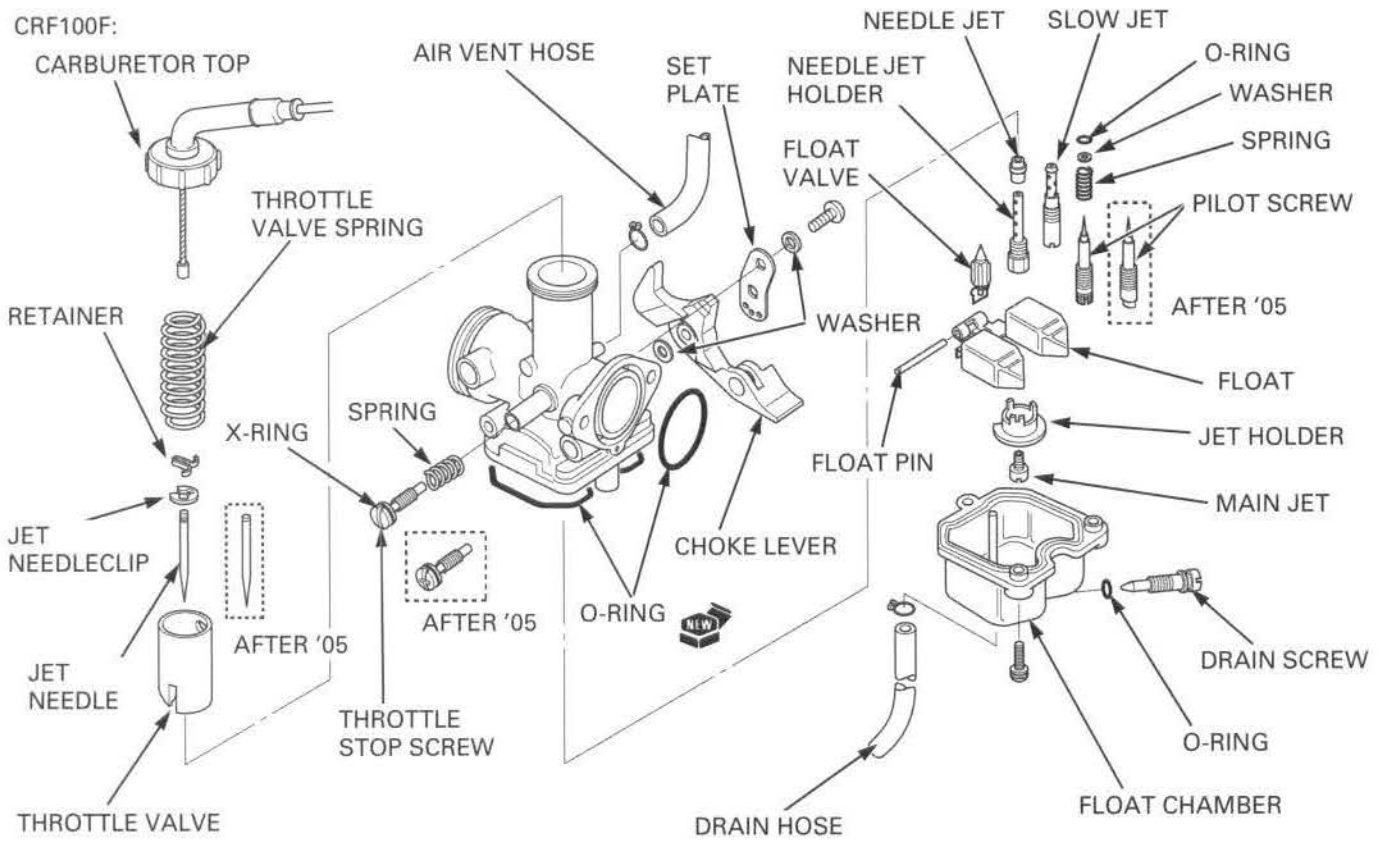

CRF80F:

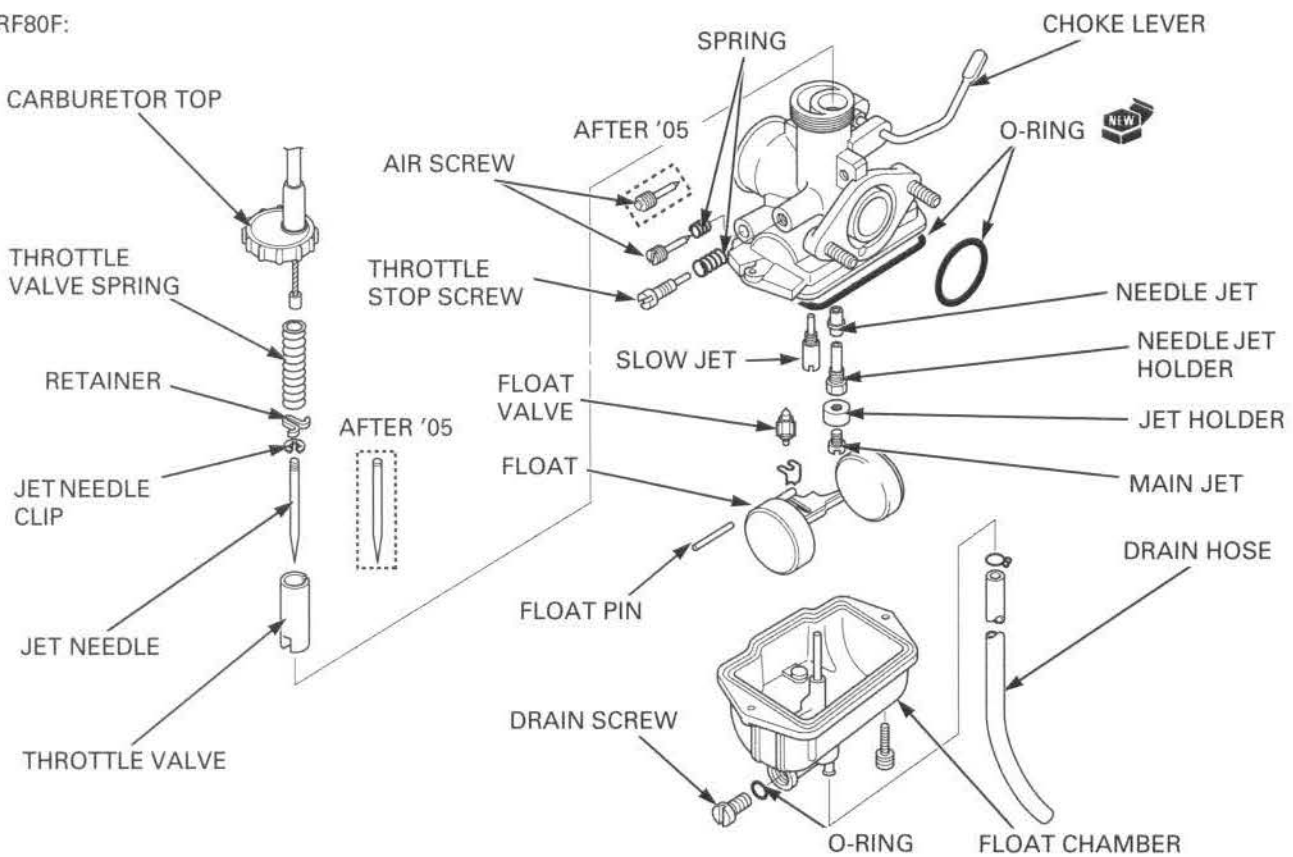

Blow open each air and fuel passage in the carburetor body with compressed air.



CRF100F: Install the following:

*Handle all jets with care. They can easily be scored or scratched.*

- Throttle stop screw/spring
- Slow jet
- Needle jet
- Needle jet holder
- Main jet
- Jet holder

Install the pilot screw with O-ring, washer and spring, and then return it to its original position as noted during removal.

After '05:

**TOOLS:**

**Pilot screw wrench (D type)** 07KMA-MS60101 or 07KMA-MN9A100 (U.S.A. only)

**Pilot screw wrench guide** 07PMA-MZ20110

Perform the pilot screw adjustment procedure if a new pilot screw is installed (page 5-18).

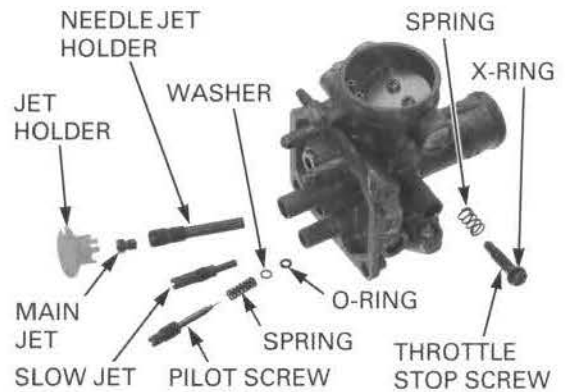

CRF80F: Install the following:

*Handle all jets with care. They can easily be scored or scratched.*

- Throttle stop screw/spring
- Slow jet
- Needle jet
- Needle jet holder
- Main jet
- Jet holder

Install the air screw with spring, and then return it to its original position as noted during removal.

After '05:

**TOOLS:**

**Pilot screw wrench (D type)** 07KMA-MS60101 or 07KMA-MN9A100 (U.S.A. only)

**Pilot screw wrench guide** 07PMA-MZ20110

Perform the air screw adjustment procedure if a new air screw is installed (page 5-19).

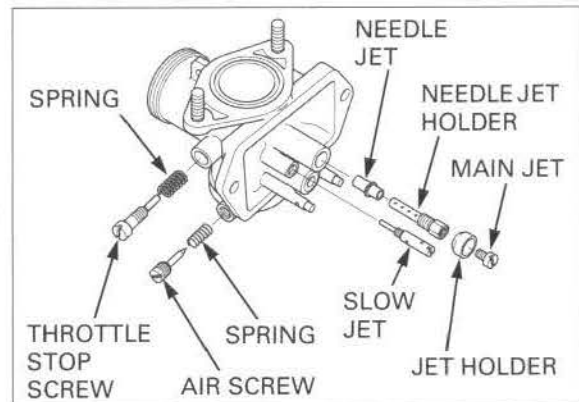

## FUEL SYSTEM

Install the float and float valve in the carburetor body, then install the float pin through the body and float.

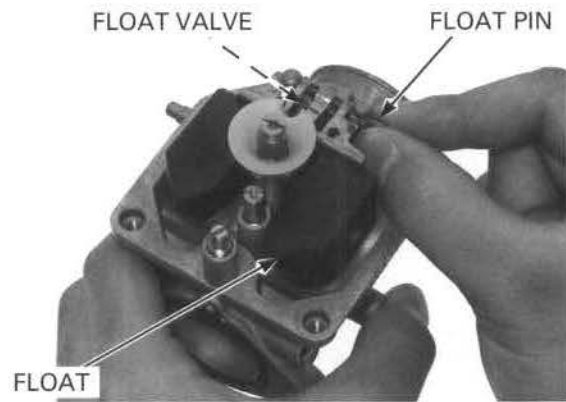

### FLOAT LEVEL INSPECTION

With the float valve seated and the float arm just touching the valve, measure the float level with the special tool as shown.

#### FLOAT LEVEL:

CRF100F: 12.5 mm (0.49 in)

CRF80F: 21.5 mm (0.85 in)

#### TOOL:

Carburetor float level gauge 07401-0010000

To adjust the float level, bend the float arm carefully until the float tip just contacts the float valve.

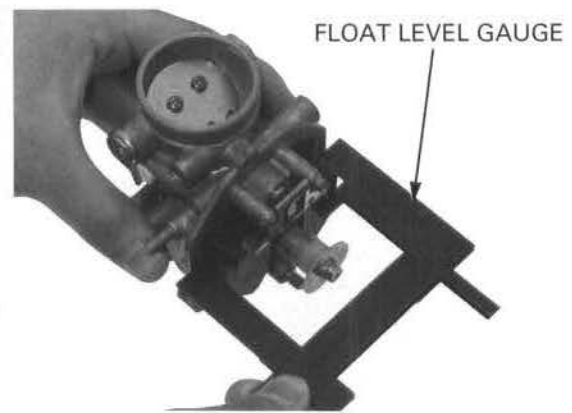

Install a new O-ring in the float chamber groove. Install the float chamber, aligning the overflow pipe with the cut-out on the jet holder.

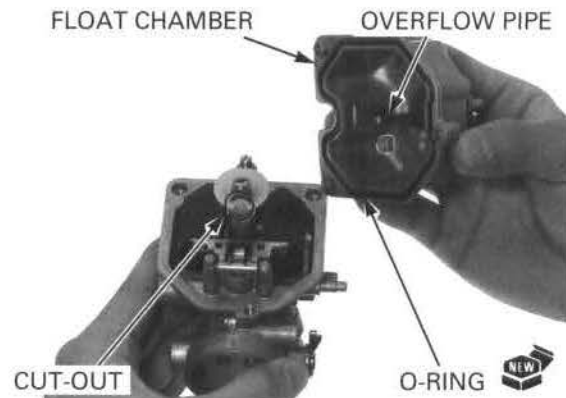

CRF100F: Install the three float chamber screws and tighten them to the specified torque.

**TORQUE: 2.1 N·m (0.2 kgf·m, 1.4 lbf·ft)**

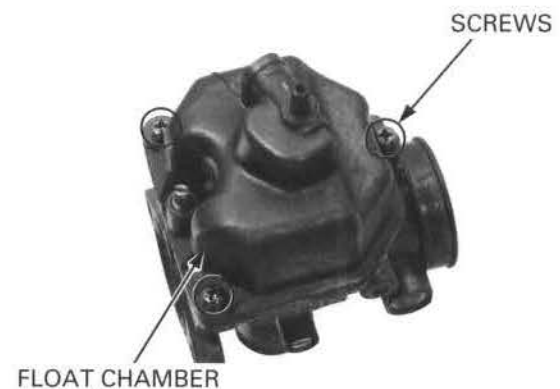

**CRF80F:** Install the two float chamber screws and tighten them to the specified torque.

**TORQUE: 2.1 N·m (0.2 kgf·m, 1.4 lbf·ft)**

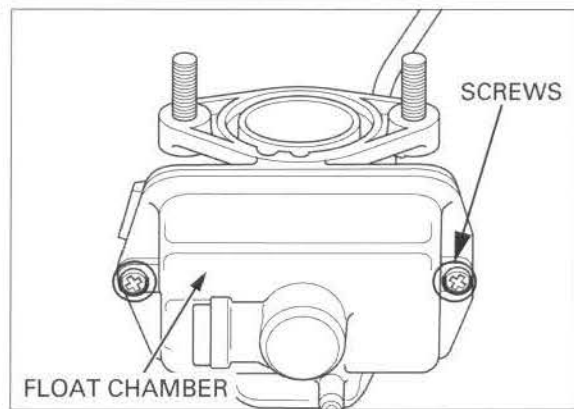

**CRF100F:** Install the washer, choke lever and set plate, then tighten the screw.

**TORQUE: 3.4 N·m (0.35 kgf·m, 2.5 lbf·ft)**

Refer to page 1-17 for carburetor hose routing.  
Connect the air vent hose and drain hose.

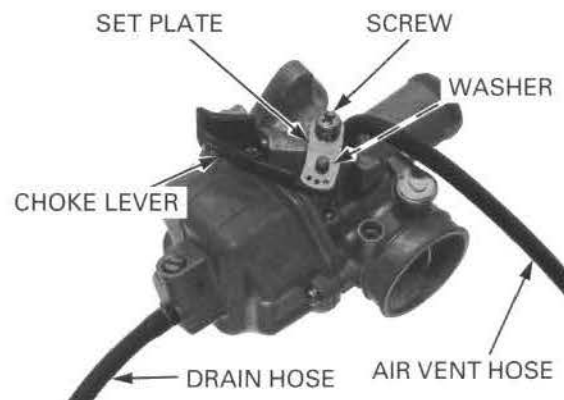

## CARBURETOR INSTALLATION

### CARBURETOR BODY

Install the new O-ring into the carburetor body groove.



Install the carburetor body to the intake manifold and tighten the nuts securely.

Install the connecting tube and tighten the connecting band screw securely.

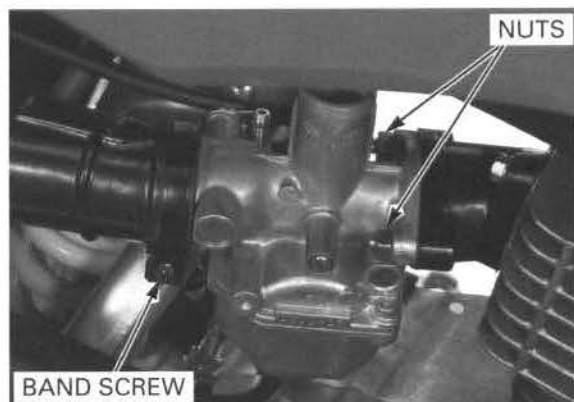

## FUEL SYSTEM

Install the air vent hose into the air cleaner housing groove.

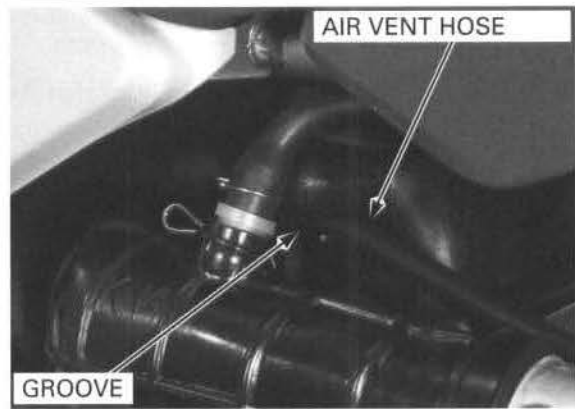

Connect the fuel hose to the carburetor.

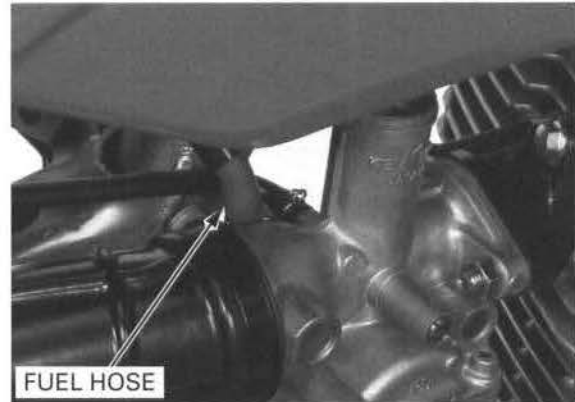

### THROTTLE VALVE

Install the needle clip on the jet needle groove.

'04 and '05: **STANDARD POSITION: 3rd groove from top**

After '05: After '05 model can not adjust the needle clip position.



Install the jet needle into the throttle valve and secure it with a jet needle retainer.

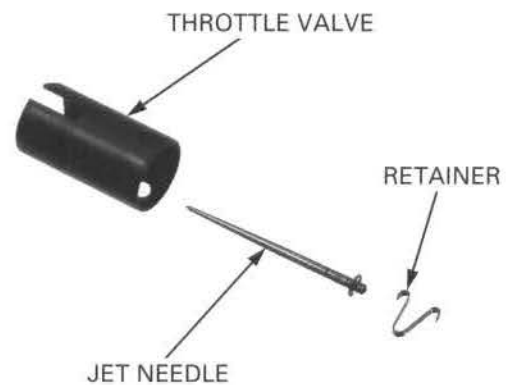

Install the throttle valve spring onto the throttle cable.

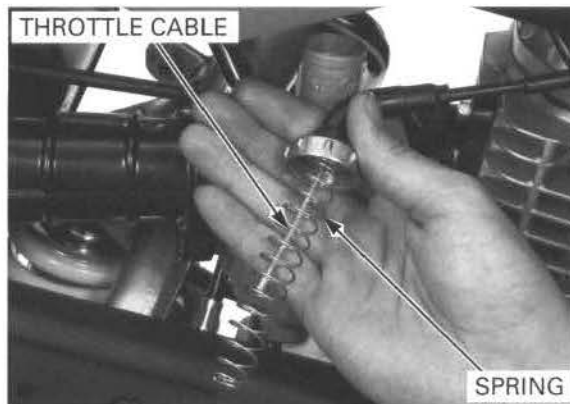

Connect the throttle cable to the throttle valve while compressing the throttle valve spring.

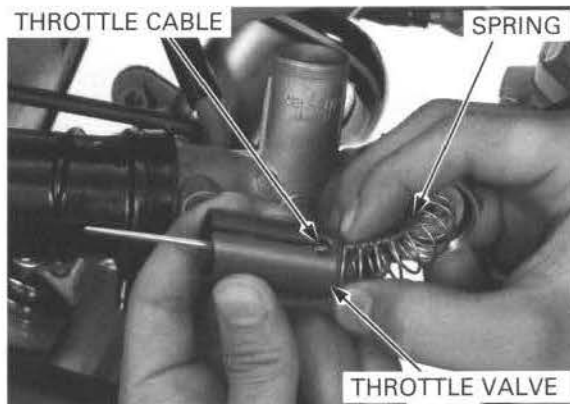

Install the throttle valve into the carburetor body, aligning its cut-out with the throttle stop screw.

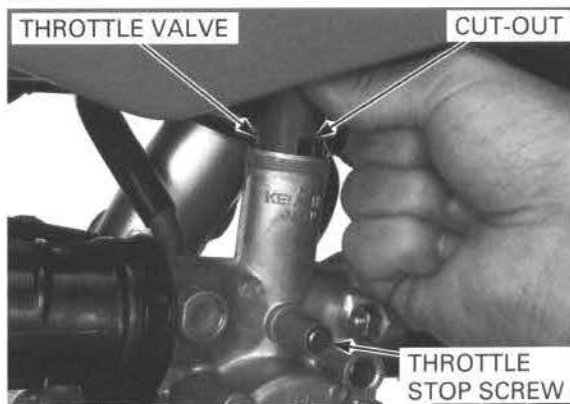

Tighten the carburetor top securely.

After installation, route the cables and hoses properly.

After installing the carburetor, check the following:

- Tighten the drain screw
- Throttle grip free play (page 3-9)
- Engine idle speed (page 3-16)
- Pilot or air screw adjustment

CRF100F: (page 5-18)

CRF80F: (page 5-19)



## PILOT SCREW ADJUSTMENT (CRF100F)

### IDLE DROP PROCEDURE

- The pilot screw is factory pre-set. Adjustment is not necessary unless the carburetor is overhauled or pilot screw is replaced.
- The engine must be warm for accurate adjustment. Ten minutes of stop-and-go riding is sufficient.
- Use a tachometer with graduations of 50 rpm or smaller that will accurately indicate 50 rpm change.

After '05: Adjust the pilot screw using following tools.

#### TOOLS:

**Pilot screw wrench (D type)** 07KMA-MS60101 or  
07KMA-MN9A100  
(U.S.A. only)

**Pilot screw wrench guide** 07PMA-MZ20110

*Damage to the pilot screw seat will occur if the pilot screw is tightened against the seat.*

1. Turn the pilot screw clockwise until it seats lightly, then back it out to specification given. This is an initial setting prior to the final pilot screw adjustment.

**INITIAL OPENING: 2-3/8 turns out**

2. Warm up the engine to operating temperature. Stop and go riding for 10 minutes is sufficient.
3. Stop the engine and connect a tachometer according to the tachometer manufacturer's instructions.

4. Start the engine and adjust the idle speed to the specified rpm with the throttle stop screw.

**IDLE SPEED: 1,400 ± 100 rpm**

5. Turn the pilot screw in or out slowly to obtain the highest engine speed.
6. Readjust the idle speed with the throttle stop screw.
7. Turn the pilot screw in gradually until the engine speed drops 100 rpm.
8. Turn the pilot screw counterclockwise the specified number of turns.

**FINAL OPENING: 3/4 turns out from step 7**

9. Readjust the idle speed with the throttle stop screw.

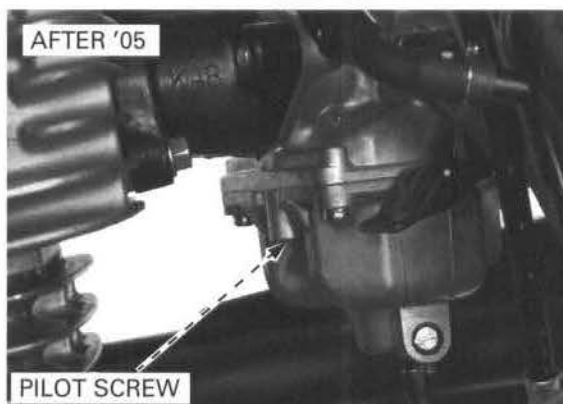



## AIR SCREW ADJUSTMENT (CRF80F)

### IDLE DROP PROCEDURE

- The air screw is factory pre-set. Adjustment is not necessary unless the carburetor is overhauled or air screw is replaced.
- The engine must be warm for accurate adjustment. Ten minutes of stop-and-go riding is sufficient.
- Use a tachometer with graduations of 50 rpm or smaller that will accurately indicate 50 rpm change.

After '05: Adjust the air screw using following tools.

#### TOOLS:

**Pilot screw wrench (D type)** 07KMA-MS60101 or  
07KMA-MN9A100  
(U.S.A. only)

**Pilot screw wrench guide** 07PMA-MZ20110

*Damage to the air screw seat will occur if the air screw is tightened against the seat.*

1. Turn the air screw clockwise until it seats lightly, then back it out to specification given. This is an initial setting prior to the final air screw adjustment.

**INITIAL OPENING: 2-1/8 turns out**

2. Warm up the engine to operating temperature. Stop and go riding for 10 minutes is sufficient.
3. Stop the engine and connect a tachometer according to its manufacturer's instructions.
4. Start the engine and adjust the idle speed to the specified rpm with the throttle stop screw.

**IDLE SPEED: 1,500 ± 100 rpm**

5. Turn the air screw in or out slowly to obtain the highest engine speed.

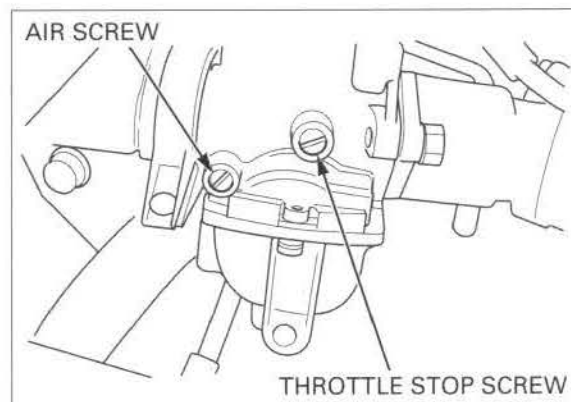
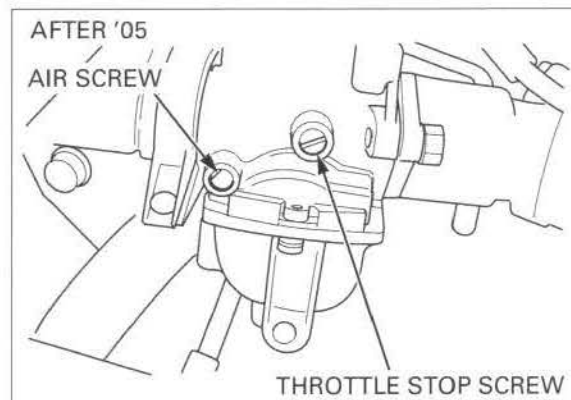
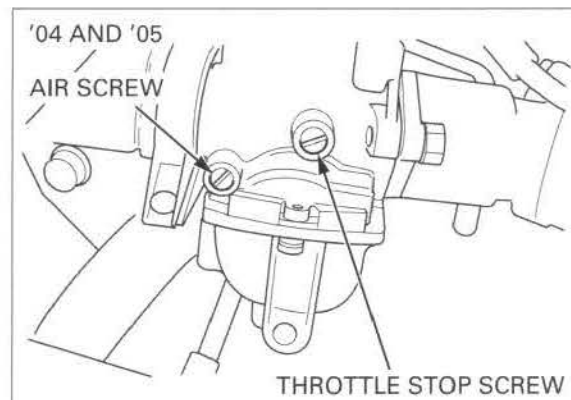

## FUEL SYSTEM

6. Readjust the idle speed with the throttle stop screw.
7. Turn the air screw out gradually until the engine speed drops 100 rpm.
8. Turn the air screw clockwise the specified number of turns.

**FINAL OPENING: 1/2 turns out from step 7**

9. Readjust the idle speed with the throttle stop screw.

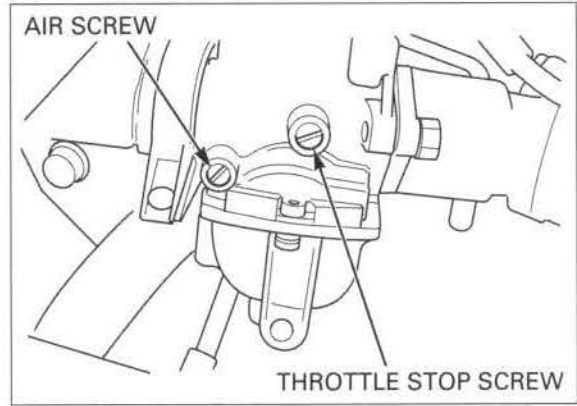

## HIGH ALTITUDE ADJUSTMENT

At high altitude, the standard carburetor air-fuel mixture will be too rich. Performance will decrease, and fuel consumption will increase. A very rich mixture will also foul the spark plug and cause hard starting. Operation at an altitude that differs from that at which this engine was certified, for extended periods of time, may increase emissions.

High altitude performance can be improved by specific modifications to the carburetor. If your customer always operates the motorcycle at altitudes above 6,500 feet (2,000 meters), you should perform this carburetor modification.

Even with carburetor modification, engine horsepower will decrease about 3.5% for each 1,000-foot (300-meter) increase in altitude. The effect of altitude on horsepower will be greater than this if no carburetor modification is made.

This engine, when operated at high altitude with the carburetor modifications for high altitude use, will meet each emission standard throughout its useful life.

The high altitude carburetor adjustment is performed as follows:

Remove the carburetor (page 5-6) and float chamber.

Replace the standard main jet with the high altitude type.

**HIGH ALTITUDE MAIN JET:**

**CRF100F:#92**

**CRF80F:#90**

Install the float chamber and carburetor (page 5-12).

CRF100F SHOWN:

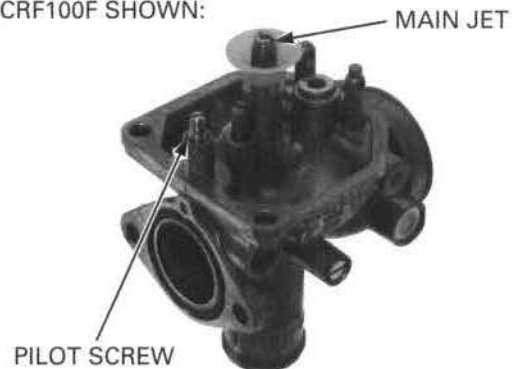

Turn out the air screw the specified number of turns from the initial setting.

**HIGH ALTITUDE PILOT OR AIR SCREW OPENING:**

- CRF100F: 3/4 turns in from factory preset
- CRF80F: 1/2 turns out from factory preset

After '05:

**TOOLS:**

- Pilot screw wrench (D type) 07KMA-MS60101 or 07KMA-MN9A100 (U.S.A. only)
- Pilot screw wrench guide 07PMA-MZ20110

Start the engine and adjust the idle speed to the high altitude setting to ensure proper high altitude operation (page 5-20).

**NOTICE**

*When the carburetor has been modified for high altitude operation, the air-fuel mixture will be too lean for low altitude use. Operation at altitudes below 5,000 ft. (1,500 m) with a modified carburetor may cause the engine overheat, resulting in serious engine damage and increased exhaust emissions.*

*For use at low altitudes, you should return the carburetor to original factory specifications.*

Replace the main jet with the standard main jet, and screw in the air screw the specified number of turns from the high altitude setting.

**STANDARD MAIN JET:**

- CRF100F:#98
- CRF80F:#95

**LOW ALTITUDE PILOT OR AIR SCREW OPENING:**

- CRF100F: 3/4 turns out from factory preset
- CRF80F: 1/2 turns in from factory preset

After '05:

**TOOLS:**

- Pilot screw wrench (D type) 07KMA-MS60101 or 07KMA-MN9A100 (U.S.A. only)
- Pilot screw wrench guide 07PMA-MZ20110

Warm up the engine and adjust the idle speed at low altitude with the throttle stop screw

CRF80F SHOWN:

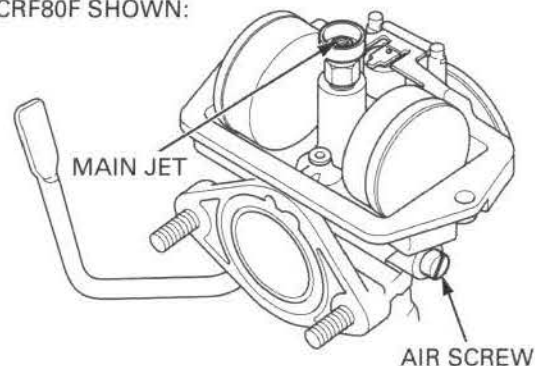

'04 AND '05 CRF100F SHOWN:

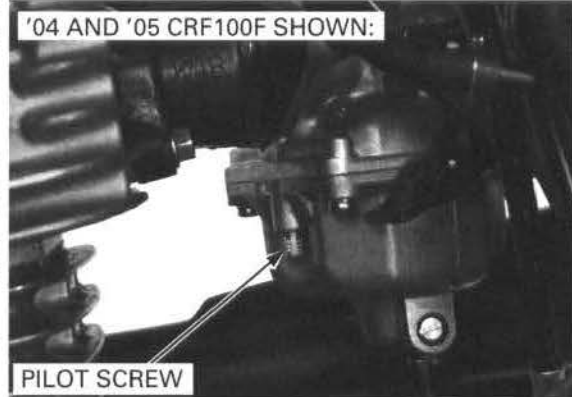

'04 AND '05 CRF80F SHOWN:

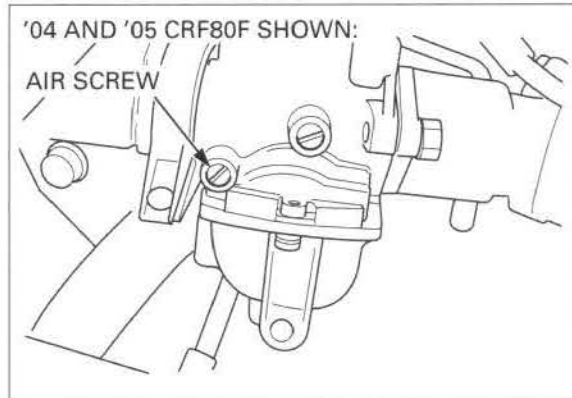

# 6. ENGINE REMOVAL/INSTALLATION

---

COMPONENT LOCATION .....	6-2	ENGINE REMOVAL .....	6-4
SERVICE INFORMATION .....	6-3	ENGINE INSTALLATION.....	6-7

# ENGINE REMOVAL/INSTALLATION

## COMPONENT LOCATION

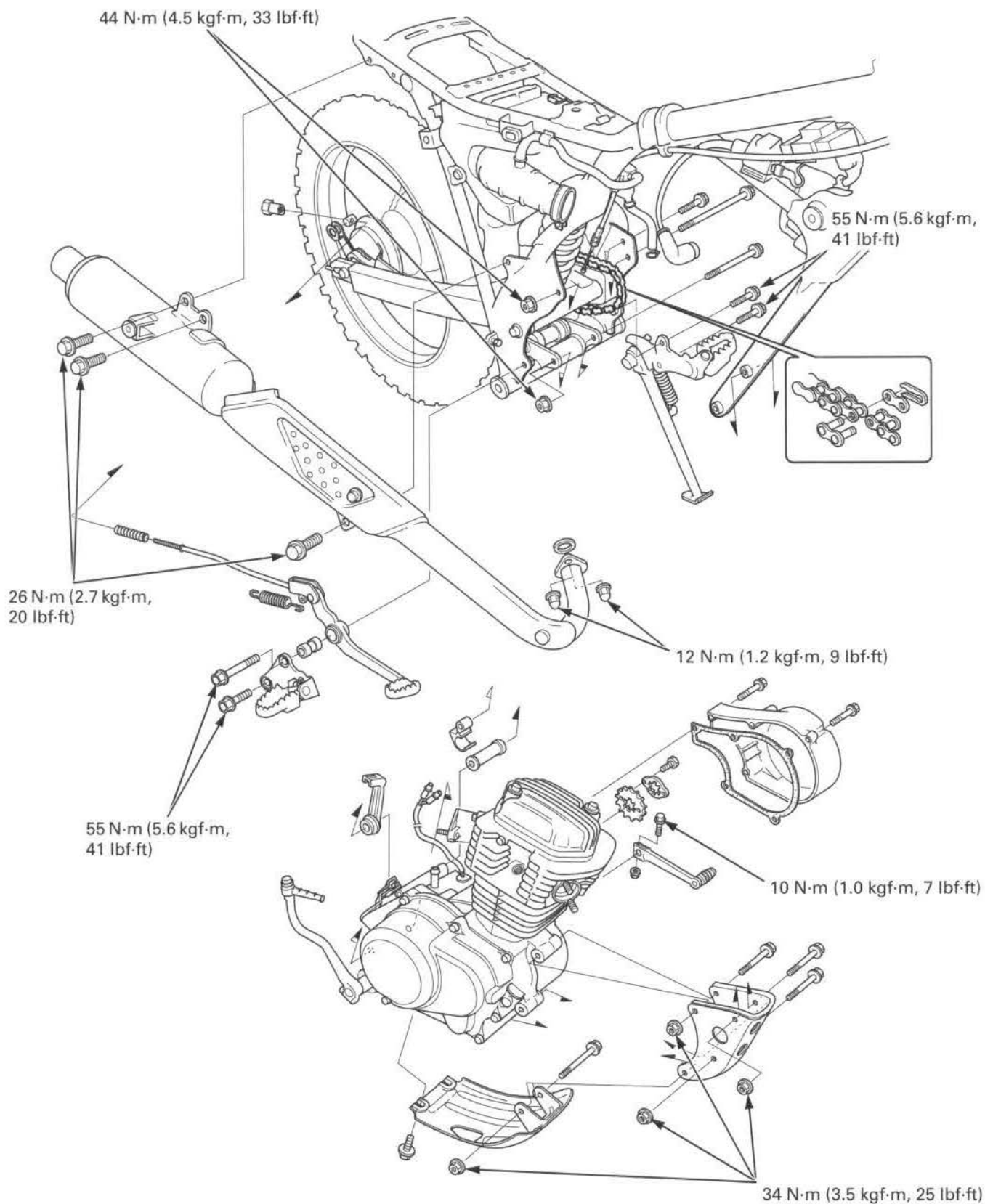

## SERVICE INFORMATION

### GENERAL

- During engine removal and installation, support the motorcycle securely using a hoist.
- Support the engine using a jack or other adjustable support to ease of engine hanger bolts removal.
- The following components can be serviced with the engine installed in the frame
  - Alternator (Section 10)
  - Camshaft (Section 7)
  - Clutch (Section 9)
  - Gearshift linkage (Section 9)
  - Oil pump (Section 4)
- The following components require engine removal for service.
  - Cylinder head/valves (Section 7)
  - Cylinder/piston (Section 8)
  - Crankshaft/transmission (Section 11)
  - Shift forks/shift drum (Section 11)

### SPECIFICATION

ITEM		SPECIFICATIONS
Engine oil capacity (At disassembly)	CRF100F	1.1 liter (1.2 US qt, 1.0 Imp qt)
	CRF80F	1.1 liter (1.2 US qt, 1.0 Imp qt)
Engine dry weight	CRF100F	21.4 kg (47.2 lbs)
	CRF80F	18.9 kg (41.7 lbs)

### TORQUE VALUES

Front engine hanger nut	34 N·m (3.5 kgf·m, 25 lbf·ft)	U-NUT
Rear engine hanger nut	44 N·m (4.5 kgf·m, 33 lbf·ft)	U-NUT
Engine hanger plate nut	34 N·m (3.5 kgf·m, 25 lbf·ft)	U-NUT
Footpeg mounting bolt	55 N·m (5.6 kgf·m, 41 lbf·ft)	
Gearshift pedal pinch bolt	10 N·m (1.0 kgf·m, 7 lbf·ft)	
Kickstarter pedal pinch bolt	12 N·m (1.2 kgf·m, 9 lbf·ft)	
Exhaust pipe mounting bolt	26 N·m (2.7 kgf·m, 20 lbf·ft)	
Exhaust pipe joint nut	12 N·m (1.2 kgf·m, 9 lbf·ft)	

### ENGINE REMOVAL

Support the motorcycle securely with a hoist or equivalent.

Drain the engine oil (page 3-14).

Remove the following:

- Right and left side cover (page 2-3)
- Seat (page 2-3)
- Muffler (page 2-7)
- Left crankcase cover (page 10-4)
- Carburetor (page 5-6)

Disconnect the spark plug cap.

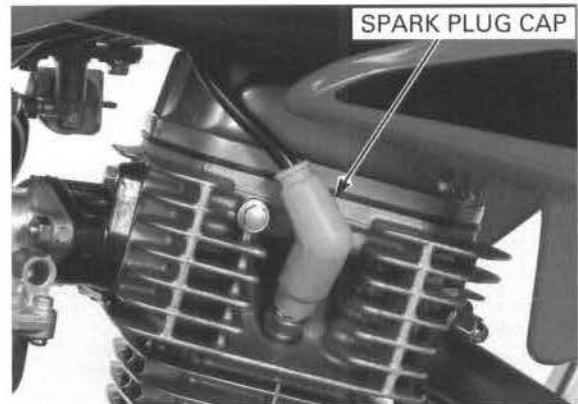

Remove the tank setting rubber.

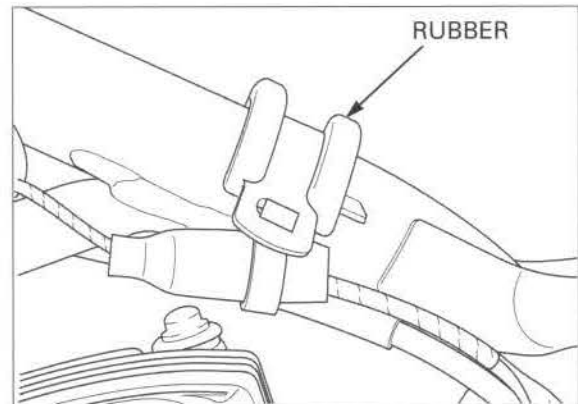

Disconnect the ignition pulse generator connector and alternator connector.



Remove the bolt and kickstarter pedal.



Disconnect the clutch cable.

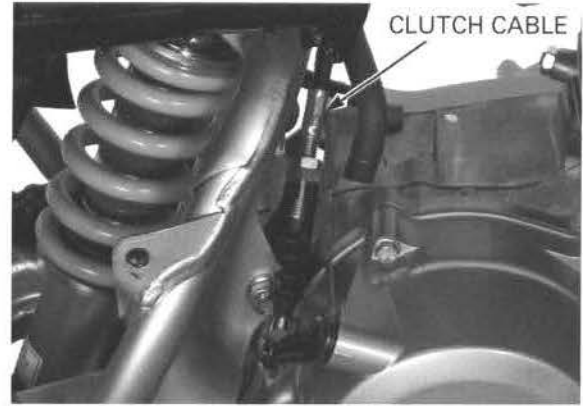

Remove the two bolts and right footpeg.

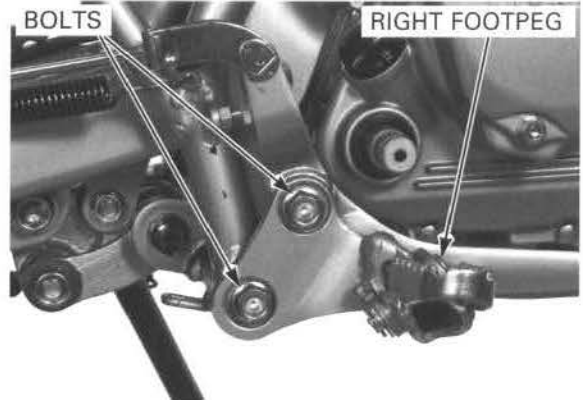

Loosen the rear axle nut and drive chain adjusting nuts.

Push the rear wheel forward to maximize slack in the drive chain.

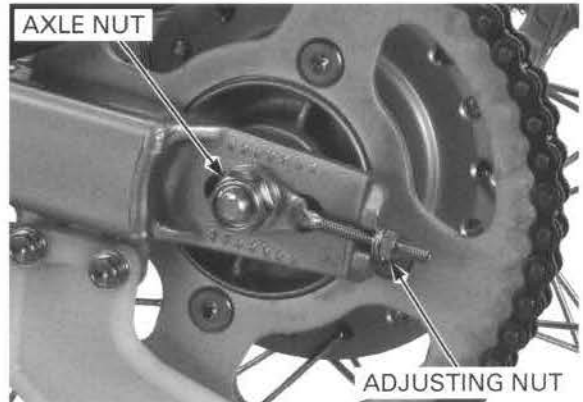

Remove the fixing plate bolts, fixing plate, drive sprocket and drive chain.

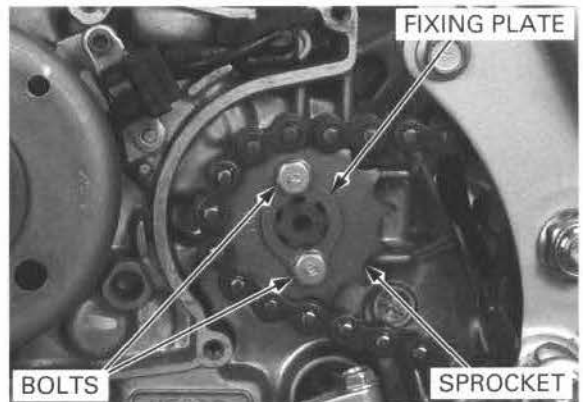



## ENGINE REMOVAL/INSTALLATION

Disconnect the crankcase breather hose from the crankcase.

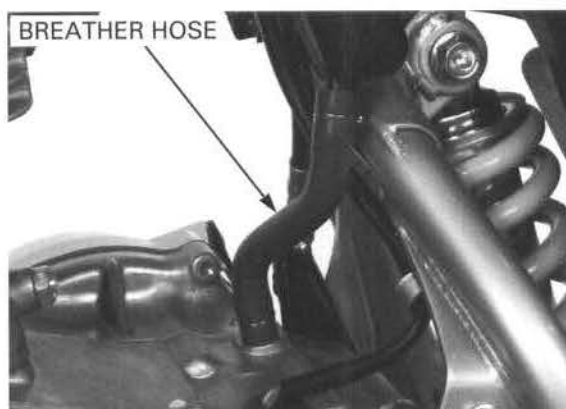

Remove the front engine hanger bolt/nut.

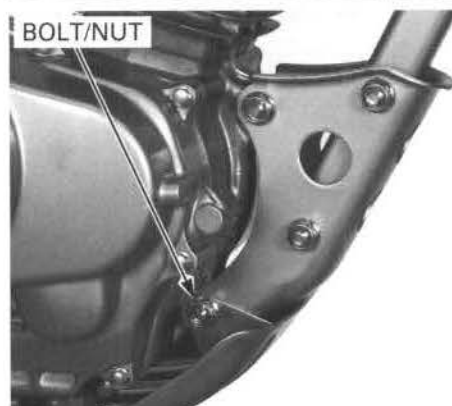

Remove the crankcase protector bolts and crankcase protector.



Remove the two bolts and left footpeg.

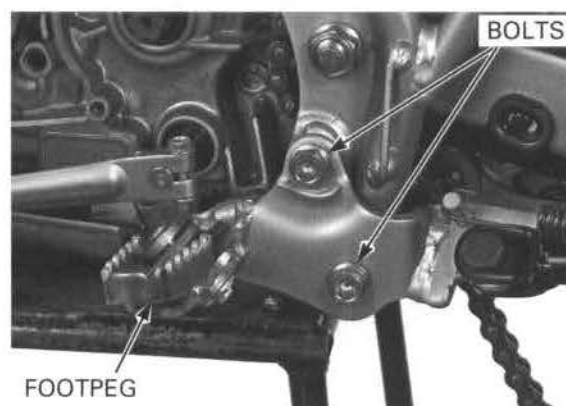

Remove the front engine hanger bolt/nut.

Remove the two engine hanger plate bolts/nuts and engine hanger plate.

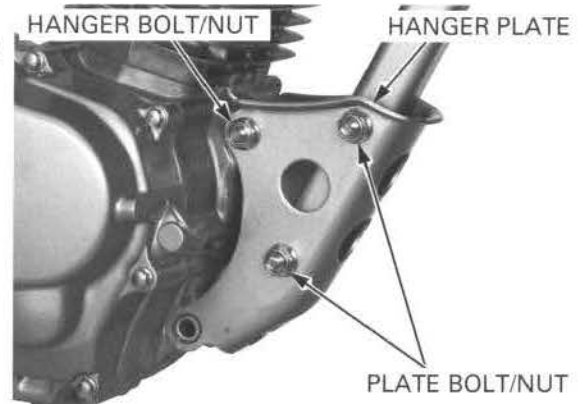

Loosen the rear engine hanger bolts/nuts.

Support the engine using a jack or other adjustable support to ease of engine hanger bolts removal.

Remove the engine hanger bolts, collars and engine from the frame.

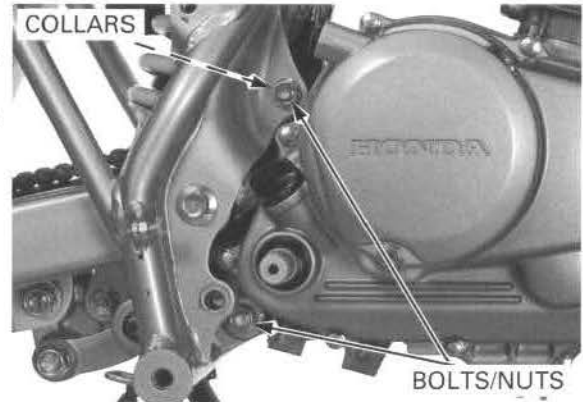

## ENGINE INSTALLATION

- Note the direction of the right engine hanger collar (clutch cable stay), left engine hanger collar and hanger bolts.
- Use a floor jack or other adjustable support to carefully maneuver the engine into place.

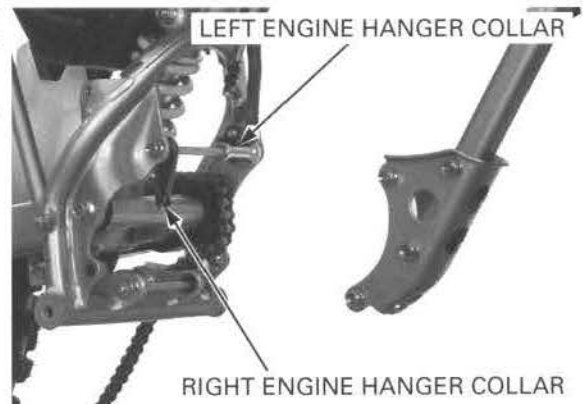

Place the engine into the frame, and install the rear engine hanger bolts from the left side.

Install the nuts, then tighten them loosely.

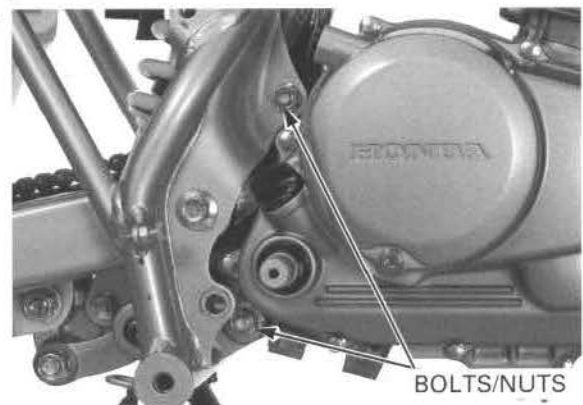

## ENGINE REMOVAL/INSTALLATION

Place the front engine hanger plate and install the three bolts from the left side.

Place the crankcase protector and install the hanger bolt from the left side.

Install the crankcase protector bolts, then tighten them loosely.

Install the hanger nuts, then tighten them loosely.

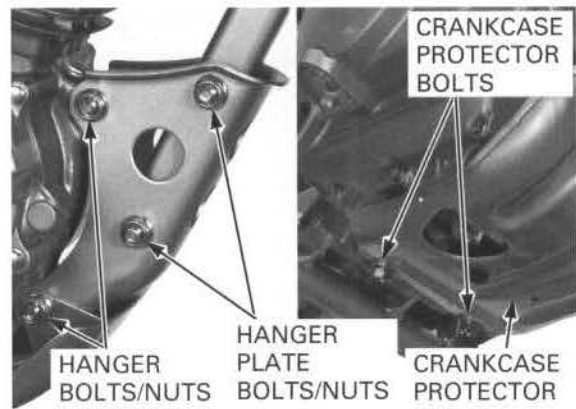

Tighten the front engine hanger nuts to the specified torque.

**TORQUE: 34 N·m (3.5 kgf·m, 25 lbf·ft)**

Tighten the engine hanger plate nuts to the specified torque.

**TORQUE: 34 N·m (3.5 kgf·m, 25 lbf·ft)**

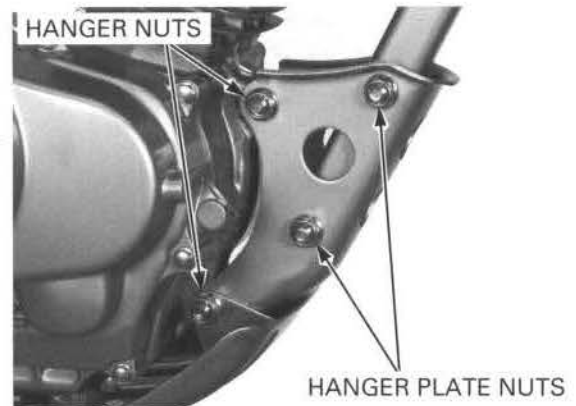

Tighten the rear engine hanger nuts to the specified torque.

**TORQUE: 44 N·m (4.5 kgf·m, 33 lbf·ft)**

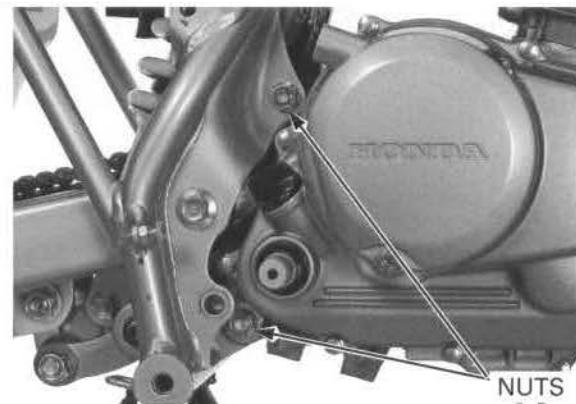

Tighten the crankcase protector bolts.

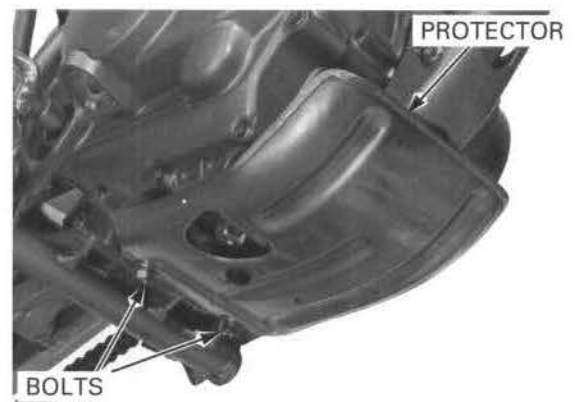

Install the left footpeg and tighten the two bolts to the specified torque.

**TORQUE: 55 N·m (5.6 kgf·m, 41 lbf·ft)**

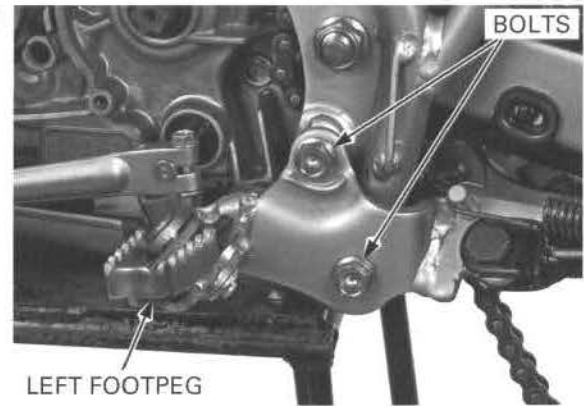

Install the right footpeg and tighten the two bolts to the specified torque.

**TORQUE: 55 N·m (5.6 kgf·m, 41 lbf·ft)**

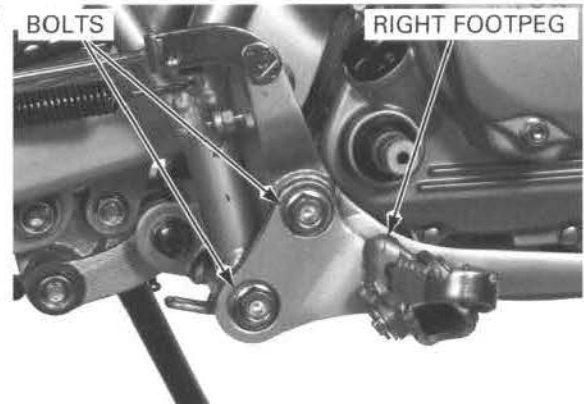

Connect the clutch cable.



Install the kickstarter pedal and tighten the bolt to the specified torque.

**TORQUE: 12 N·m (1.2 kgf·m, 9 lbf·ft)**



## ENGINE REMOVAL/INSTALLATION

Install the drive sprocket onto the counter shaft.  
Install the fixing plate and tighten the bolts.

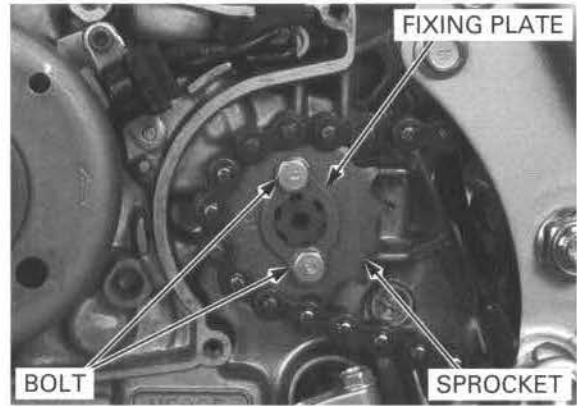

Connect the alternator and ignition pulse generator connector.



Install the tank setting rubber against the rubber stopper.

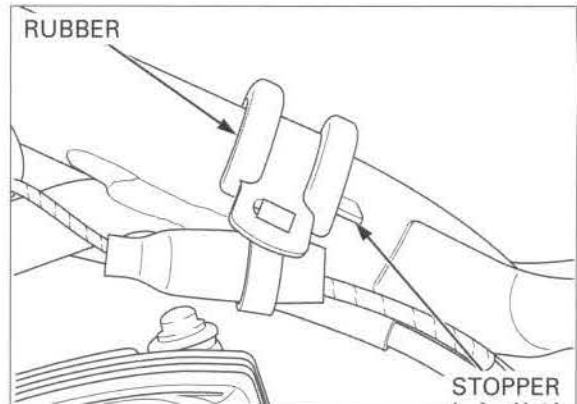

Connect the crankcase breather hose to the crankcase.



Install the following:

- Left crankcase cover (page 10-8)
- Muffler (page 2-7)
- Carburetor (page 5-15)
- Seat, Side cover (page 2-3)

Connect the spark plug cap.

Pour the recommended engine oil to the proper level (page 3-14).

Adjust the drive chain slack (page 3-17).

Adjust the clutch lever free play (page 3-22).

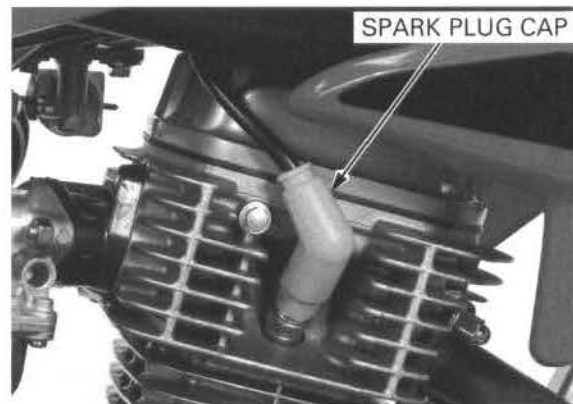

# 7. CYLINDER HEAD/VALVES

---

COMPONENT LOCATION .....	7-2	CYLINDER HEAD INSPECTION .....	7-11
SERVICE INFORMATION .....	7-3	VALVE GUIDE REPLACEMENT .....	7-13
TROUBLESHOOTING .....	7-5	VALVE SEAT INSPECTION/ REFACING .....	7-13
CYLINDER COMPRESSION TEST .....	7-6	CYLINDER HEAD ASSEMBLY .....	7-16
CAMSHAFT REMOVAL .....	7-6	CYLINDER HEAD INSTALLATION .....	7-17
CYLINDER HEAD REMOVAL .....	7-10	CAMSHAFT INSTALLATION .....	7-18
CYLINDER HEAD DISASSEMBLY .....	7-10		

COMPONENT LOCATION

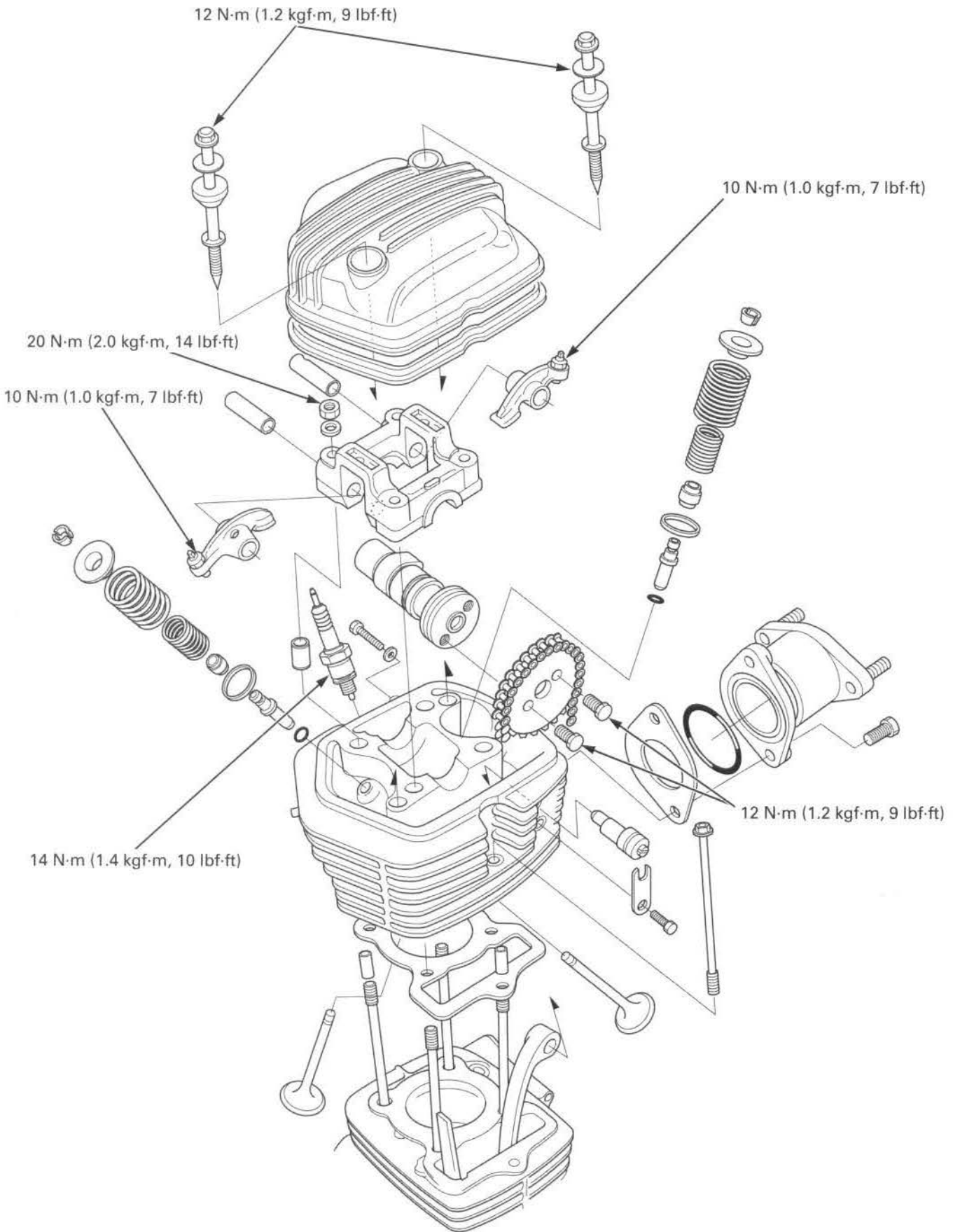



## SERVICE INFORMATION

### GENERAL

- This section covers service of the cylinder head, valves, and camshaft.
- The camshaft can be removed with the engine in the frame, but the engine must be removed from the frame to perform other service.
- When disassembling, mark and store the disassembled parts to ensure that they are reinstalled in their original locations.
- Clean all disassembled parts with cleaning solvent and dry them by blowing them off with compressed air before inspection.
- Rocker arm lubricating oil is fed through the oil passage in the cylinder head. Clean the oil passage before assembling the cylinder head.
- Be careful not to damage the mating surfaces when removing the cylinder head cover and cylinder head.

### SPECIFICATIONS

Unit: mm (in)







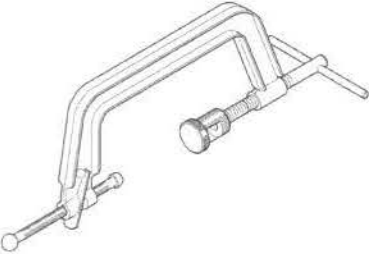

ITEM				STANDARD	SERVICE LIMIT
Cylinder compression	CRF100F			1,176 kPa (12.0 kgf/cm <sup>2</sup> , 171 psi) at 1,000 rpm	-
	CRF80F			1,176 kPa (12.0 kgf/cm <sup>2</sup> , 171 psi) at 1,000 rpm	-
Cylinder head warpage				-	0.10 (0.004)
Valve and valve guide	Valve clearance	IN		0.05(0.002)	-
		EX		0.05(0.002)	-
	Valve stem O.D.	IN		5.450 – 5.465 (0.2145 – 0.2151)	5.420 (0.2134)
		EX		5.430 – 5.445 (0.2137 – 0.2143)	5.400 (0.2126)
	Valve guide I.D.	IN		5.475 – 5.485 (0.2155 – 0.2159)	5.50 (0.217)
		EX		5.475 – 5.485 (0.2155 – 0.2159)	5.50 (0.217)
	Stem to guide clearance	IN		0.010 – 0.035 (0.0004 – 0.0013)	0.08 (0.003)
		EX		0.030 – 0.055 (0.0012 – 0.0022)	0.10 (0.004)
Valve seat width	IN/EX		1.70(0.06)	2.1 (0.08)	
Valve spring free length	Inner	IN/EX		28.05 (1.104)	27.6 (1.09)
	Outer	IN/EX		34.80 (1.370)	33.7 (1.33)
Rocker arm/shaft	Rocker arm I.D.	IN/EX		10.000 – 10.015 (0.3937 – 0.3943)	10.1 (0.40)
	Rocker arm shaft O.D.	IN/EX		9.978 – 9.987 (0.3928 – 0.3932)	9.91 (0.390)
	Rocker arm to shaft clearance	IN/EX		0.013 – 0.037 (0.0005 – 0.0014)	0.08 (0.003)
Camshaft	Cam lobe height	CRF100F	IN	27.860 – 28.040 (1.0968 – 1.1039)	27.80 (1.094)
			EX	27.776 – 27.950 (1.0935 – 1.1004)	27.70 (1.091)
		CRF80F	IN	28.007 – 28.207 (1.1026 – 1.1105)	27.95 (1.100)
			EX	27.825 – 28.025 (1.0955 – 1.1033)	27.75 (1.093)
	Journal O.D.	CRF100F	IN	19.950 – 19.968 (0.7854 – 0.7861)	19.90(0.783)
			EX	19.950 – 19.968 (0.7854 – 0.7861)	19.90(0.783)
		CRF80F	IN	19.950 – 19.968 (0.7854 – 0.7861)	19.90(0.783)
			EX	19.950 – 19.968 (0.7854 – 0.7861)	19.90(0.783)
Runout			-	0.03 (0.001)	
Camshaft holder I.D.	CRF100F		20.008 – 20.063 (0.7877 – 0.7899)	20.15(0.793)	
	CRF80F		20.008 – 20.063 (0.7877 – 0.7899)	20.15(0.793)	
Oil clearance	CRF100F		0.040 – 0.113 (0.0016 – 0.0044)	0.20(0.008)	
	CRF80F		0.040 – 0.113 (0.0016 – 0.0044)	0.20(0.008)	

### TORQUE VALUES

Cylinder head cover bolt	12 N·m (1.2 kgf·m, 9 lbf·ft)
Camshaft holder nut	20 N·m (2.0 kgf·m, 14 lbf·ft)
Cam sprocket bolt	12 N·m (1.2 kgf·m, 9 lbf·ft)
Cam chain tensioner adjusting bolt lock nut	12 N·m (1.2 kgf·m, 9 lbf·ft)
Spark plug	14 N·m (1.4 kgf·m, 10 lbf·ft)
Valve adjusting screw lock nut	10 N·m (1.0 kgf·m, 7 lbf·ft)

# CYLINDER HEAD/VALVES

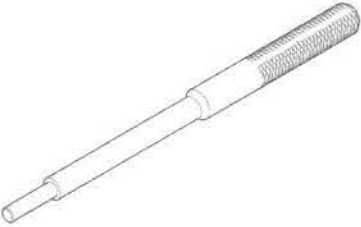
## TOOLS

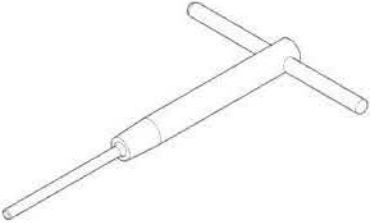
<p>Valve spring compressor 07757-0010000</p> 	<p>Seat cutter, 24.5 mm (EX, 45°) 07780-0010100</p>  <p>or equivalent commercially available in U.S.A.</p>	<p>Seat cutter, 27.5 mm (IN, 45°) 07780-0010200</p>  <p>or equivalent commercially available in U.S.A.</p>
<p>Flat cutter, 22 mm (EX, 32°) 07780-0012601</p>  <p>or equivalent commercially available in U.S.A.</p>	<p>Flat cutter, 25 mm (IN, 32°) 07780-0012000</p>  <p>or equivalent commercially available in U.S.A.</p>	<p>Interior cutter, 22 mm (IN/EX, 60°) 07780-0014000</p>  <p>or equivalent commercially available in U.S.A.</p>
<p>Valve guide driver, 5.5 mm 07742-0010100</p> 	<p>Valve guide reamer, 5.485 mm 07984-0980001</p>  <p>or 07984-098000D (U.S.A. only)</p>	<p>Cutter holder, 5.5 mm 07781-0010101</p>  <p>or equivalent commercially available in U.S.A.</p>

## TROUBLESHOOTING

- Engine top-end problems usually affect engine performance. These problem can be diagnosed by a compression test or by tracing engine noises to the top-end with a sounding rod stethoscope.
- If the performance is poor at low speeds, check for white smoke in the crankcase breather hose. If the hose is smoky, check for a seized piston ring (page 8-5).

### Low compression

- Valves:
  - Incorrect valve adjustment
  - Burned or bent valve
  - Incorrect valve timing
  - Weak valve spring
  - Uneven valve seating
- Cylinder head:
  - Leaking or damaged head gasket
  - Warped or cracked cylinder head
- Worn cylinder, piston or piston rings (page 8-6)

### High compression

- Excessive carbon build-up on piston crown or on combustion chamber

### Excessive smoke

- Worn valve stem or valve guide
- Damaged stem seal
- Worn cylinder, piston or piston rings (page 8-6)

### Excessive noise

- Cylinder head:
  - Incorrect valve adjustment
  - Sticking valve or broken valve spring
  - Damaged or worn camshaft
  - Loose or worn cam chain
  - Worn or damaged cam chain
  - Worn or damaged cam chain tensioner
  - Worn cam sprocket teeth
  - Worn rocker arm and/or shaft
- Worn cylinder, piston or piston rings

### Rough idle

- Low cylinder compression

### Overheating

- Excessive carbon build-up on the piston head or combustion chamber

### Knocking or abnormal noise

- Excessive carbon build-up

### CYLINDER COMPRESSION TEST

Warm up the engine.  
Stop the engine and remove the spark plug.  
Connect a compression gauge.  
open the throttle grip fully and crank the engine with the kickstarter until the gauge reading stops rising.  
Operate the kickstarter pedal several times.

#### COMPRESSION PRESSURE:

**CRF100F:** 1,176 kPa (12.0 kg/cm<sup>2</sup>, 171 psi) at 1,000 rpm

**CRF80F:** 1,176 kPa (12.0 kg/cm<sup>2</sup>, 171 psi) at 1,000 rpm

Low compression can be caused by:

- Blown cylinder head gasket
- Improper valve adjustment
- Valve leakage
- Worn piston ring or cylinder (Section 8)

High compression can be caused by:

- Carbon deposits in combustion chamber or on piston head

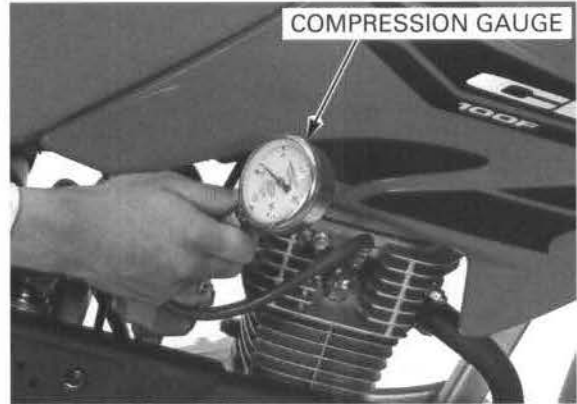

### CAMSHAFT REMOVAL

Remove the following.

- Side cover (page 2-3)
- Seat (page 2-3)
- Fuel tank (page 2-4)
- Left crankcase cover (page 10-4)

Remove the two bolts and cylinder head cover.

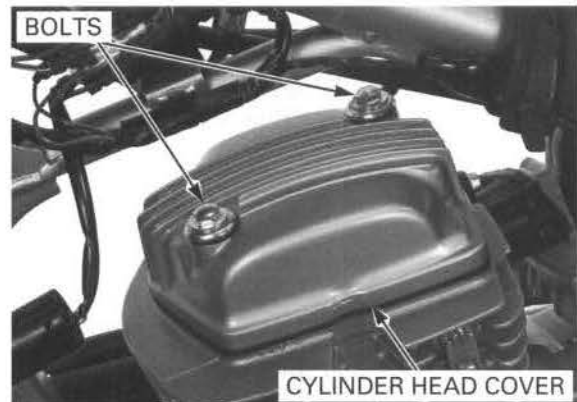

Loosen the cam chain tensioner adjusting bolt lock nut and adjusting bolt.

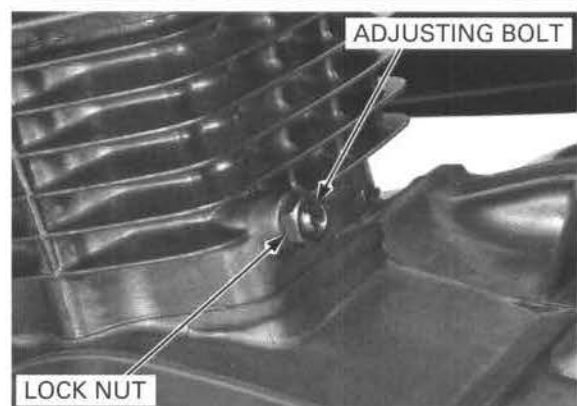

Release the cam chain tension by pushing the chain tensioner with a screwdriver, then tighten the adjusting bolt and lock nut.

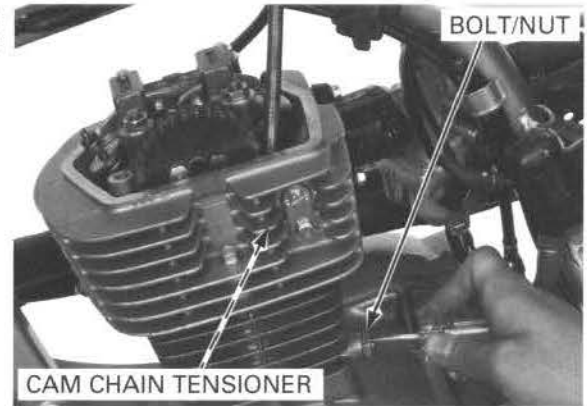

If you will be remove the cylinder head, remove the cam chain tension adjuster set plate bolt, set plate and adjuster to release the cam chain tension at this time.

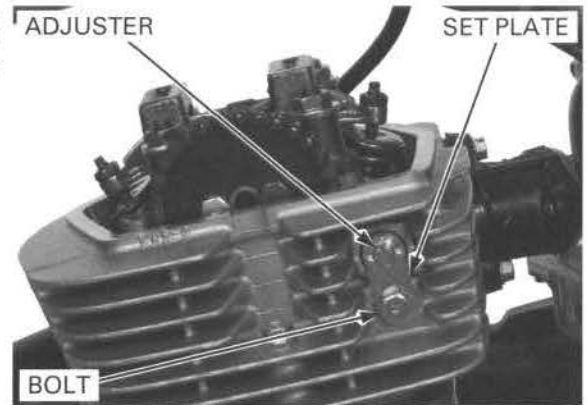

Loosen the cam sprocket bolt, turn the crankshaft counterclockwise one full turn (360°) and Loosen the other cam sprocket bolt.



Turn the cam sprocket with its bolt holes in parallel to the cylinder head surface and "O" mark facing up.



## CYLINDER HEAD/VALVES

Remove the four camshaft holder nuts and washers in a crisscross pattern in 2 - 3 steps.

Remove the camshaft holder.

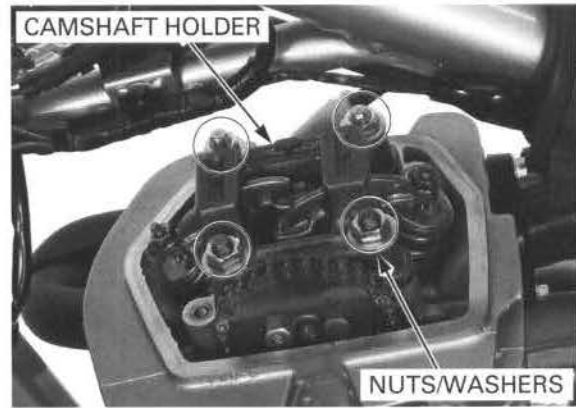

Remove the camshaft and dowel pins.

Suspend the cam chain with a piece of wire to keep it from falling into the crankcase.

Remove the cam sprocket from the camshaft.

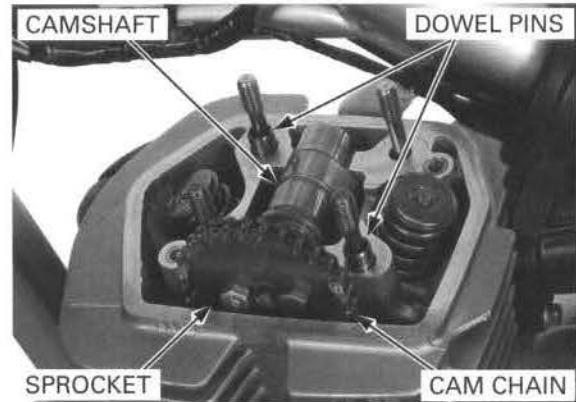

### CAM LOBE HEIGHT

*Inspect the rocker arm sliding surface if the cam lobe is worn or damaged.*

Inspect the cam lobe surfaces for wear, scoring or evidence of insufficient lubrication. Measure each cam lobe height using a micrometer.

#### SERVICE LIMITS:

CRF100F: IN: 27.80 mm (1.094 in)  
EX: 27.70 mm (1.091 in)  
CRF80F: IN: 27.95 mm (1.100 in)  
EX: 27.75 mm (1.093 in)



### CAMSHAFT JOURNAL

*Inspect the oil passages and camshaft holder for wear or damage if the journal surface is worn or damaged.*

Inspect the camshaft journal surfaces for wear, scoring or evidence of insufficient lubrication. Measure the O.D. of each camshaft journal using a micrometer.

**SERVICE LIMIT:** 19.90 mm (0.783 in)



**CAMSHAFT HOLDER**

Tap the camshaft holder with a plastic hammer to remove the intake rocker arm shaft.

Temporarily install an 8 mm bolt into the exhaust rocker arm shaft and pull the shaft out of the holder.

Remove the rocker arms.

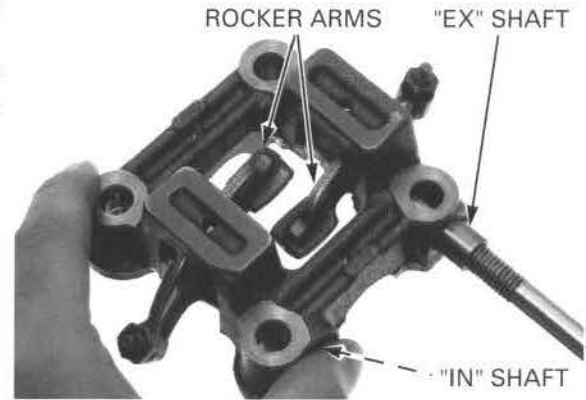

*If any rocker arms require servicing or replacement, inspect the cam lobes for scoring, chipping or flat spots.*

Inspect the rocker arms and shafts for wear or damage.

Measure the rocker arm I.D.

**SERVICE LIMIT: 10.1 mm (0.40 in)**

Measure the rocker arm shaft O.D.

**SERVICE LIMIT: 9.91 mm (0.390 in)**

Calculate the rocker arm-to-shaft clearance.

**SERVICE LIMIT: 0.08 mm (0.003 in)**



**CAMSHAFT OIL CLEARANCE**

Wipe any oil from the journals of the camshaft, cylinder head and camshaft holders.

Lay a strip of plastigauge lengthwise on top of each camshaft journal.

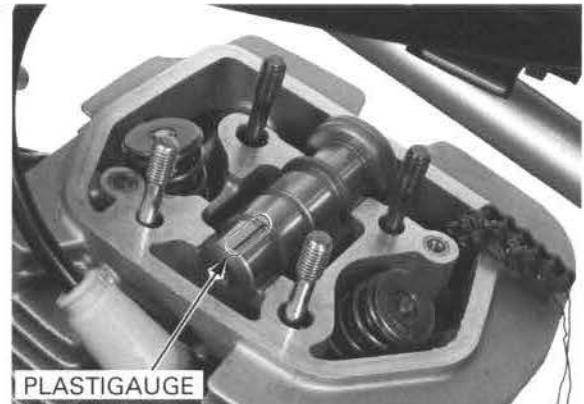

*Do not the camshaft when using plastigauge.*

Install the camshaft holder and tighten the nuts in a crisscross pattern in 2 – 3 steps.

**TORQUE: 20 N·m (2.0 kgf·m, 14 lbf·ft)**





## CYLINDER HEAD/VALVES

Remove the camshaft holder and measure the width of each plastigauge.

The widest thickness determines the oil clearance.

**SERVICE LIMIT: 0.20 mm (0.008 in)**

When the service limits are exceeded, replace the camshaft and recheck the oil clearance.

Replace the cylinder head and camshaft holders as a set if the clearance still exceeds the service limit.

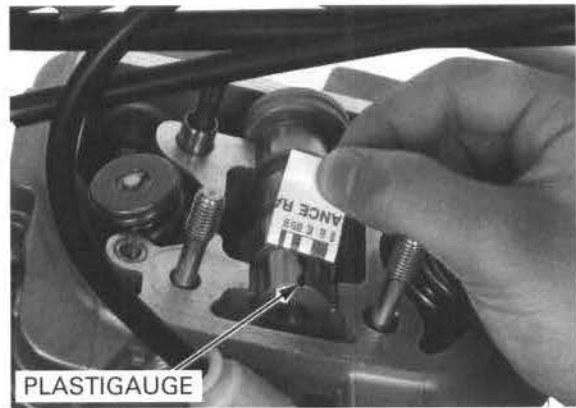

## CYLINDER HEAD REMOVAL

Remove the following:

- Engine (page 6-4)
- Camshaft (page 7-6)

Remove the carburetor intake pipe.

Remove the cam chain tensioner set plate bolt, set plate and adjuster.

*Do not allow the cam chain to fall into the crankcase; hold the cam chain with a piece of wire.*

Remove the cylinder head mounting bolt and the cylinder head.

Remove the gasket and dowel pins.

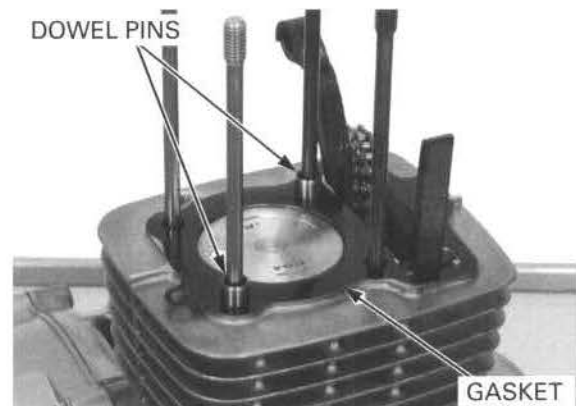
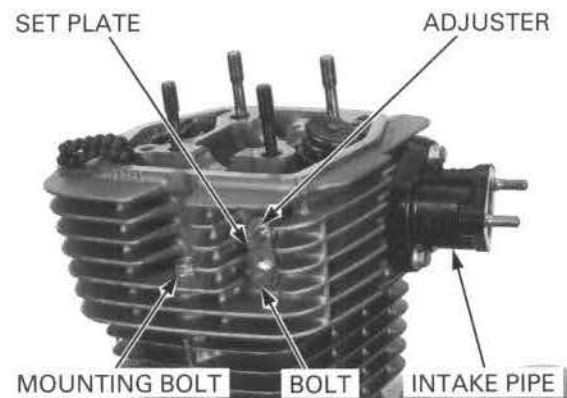

## CYLINDER HEAD DISASSEMBLY

*To prevent loss of tension, do not compress the valve springs more than necessary to remove the cotters.*

Remove the valve spring cotters using a valve spring compressor.

**TOOL:**

**Valve spring compressor**

**07757-0010000**





Mark all parts during disassembly so they can be placed back in their original locations.

Remove the following:

- Spring retainer
- Outer and inner valve springs
- Valve
- Stem seal
- Valve spring seat

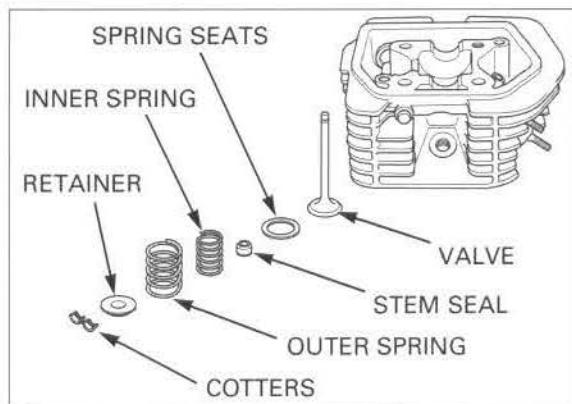
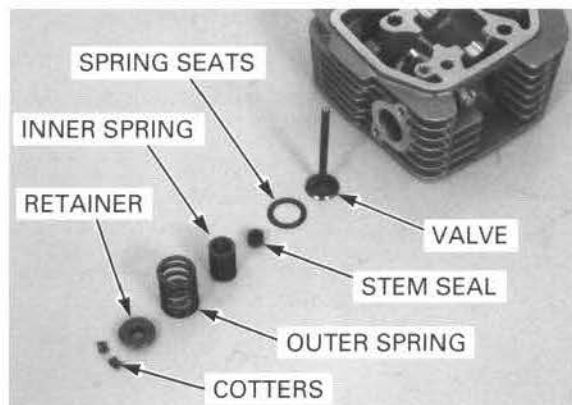

## CYLINDER HEAD INSPECTION

### CYLINDER HEAD

Avoid damaging the gasket surface.

Remove the carbon deposits from the combustion chamber.

Clean off any gasket material from the cylinder head surface.

Check the spark plug hole and valve area for cracks.

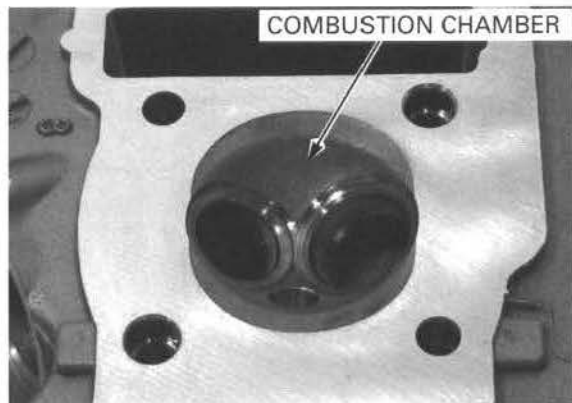

Check the cylinder head for warpage using a straight edge and feeler gauge.

**SERVICE LIMIT: 0.10 mm (0.004 in)**

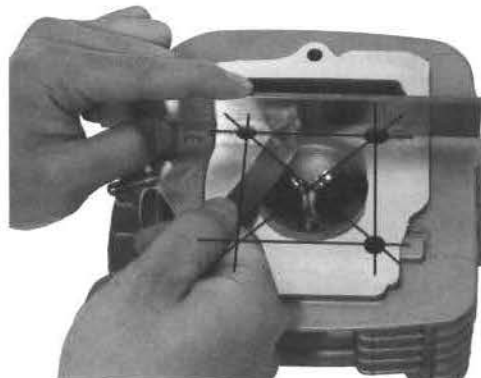

### VALVE SPRING

Check the valve springs for fatigue or damage.

Measure the free length of the inner and outer valve springs.

#### SERVICE LIMITS:

**Inner:** 27.6 mm (1.09 in)

**Outer:** 33.7 mm (1.33 in)

Replace the springs if they are shorter than the service limits.

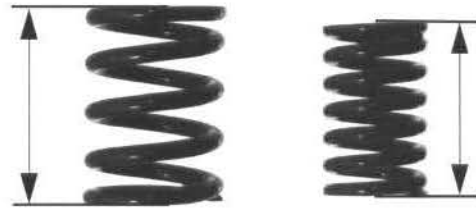

OUTER

INNER

### VALVE/VALVE GUIDE

Inspect each valve for bending, burning, scratches or abnormal stem wear.

Check the valve movement in the guide.

Measure and record the valve stem O.D.

#### SERVICE LIMITS:

**IN:** 5.420 mm (0.2134 in)

**EX:** 5.400 mm (0.2126 in)

VALVE STEM

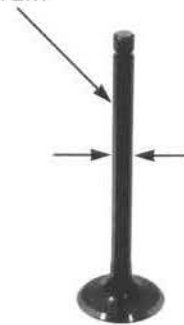

Ream the guides to remove any carbon deposits before checking clearances.

Insert the reamer from the camshaft side of the head and always rotate the reamer clockwise.

#### TOOLS:

Valve guide reamer, 5.485 mm **07984-0980001** or **07984-098000D** (U.S.A. only)

VALVE GUIDE REAMER



Measure and record each valve guide I.D.

#### SERVICE LIMITS:

**IN:** 5.50 mm (0.217 in)

**EX:** 5.50 mm (0.217 in)

Calculate the stem-to-guide clearance.

#### SERVICE LIMITS:

**IN:** 0.08 mm (0.003 in)

**EX:** 0.10 mm (0.004 in)

*Reface the valve seats whenever the valve guides are replaced (page 7-13)*

If the stem-to-guide clearance exceeds the service limits, determine if a new guide with standard dimensions would bring the clearance within tolerance. If so, replace any guides as necessary and ream to fit.

If the stem-to-guide clearance exceeds the service limits with new guides, also replace the valves and guides.

VALVE GUIDE

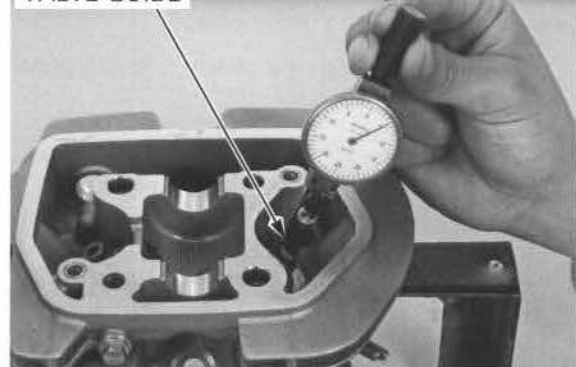

## VALVE GUIDE REPLACEMENT

Chill the replacement valve guides in the freezer section of a refrigerator for about an hour.

Heat the cylinder head to 100 – 150°C (212 – 300°F) with a hot plate or oven.

To avoid burns, wear heavy gloves when handling the heated cylinder head.

Support the cylinder head and drive out the valve guides from the combustion chamber side of the cylinder head.

**TOOL:**

**Valve guide driver, 5.5 mm      07742-0010100**

Drive in the guides from the top of the head.

**TOOL:**

**Valve guide driver, 5.5 mm      07742-0010100**

Let the cylinder head cool to room temperature.

Ream the new valve guide after installation.

*Use cutting oil on the reamer during this operation.*

Insert the reamer from the combustion chamber side of the cylinder head and always rotate the reamer clockwise.

**TOOLS:**

**Valve guide reamer, 5.485 mm      07984-0980001 or  
07984-098000D  
(U.S.A. only)**

Clean the cylinder head thoroughly to remove any metal particles.

Reface the valve seat (page 7-13).

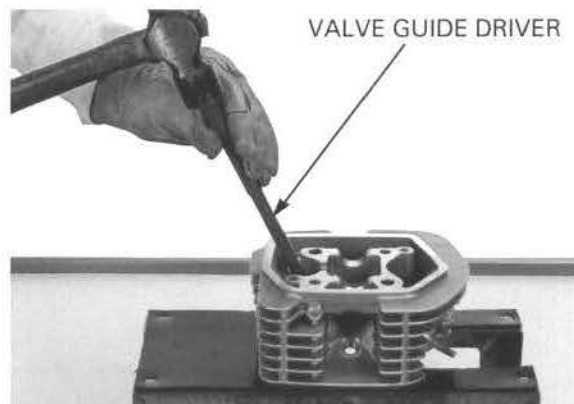

## VALVE SEAT INSPECTION/REFACING

Clean the intake and exhaust valves thoroughly to remove carbon deposits.

Apply a light coating of Prussian Blue to each valve seat.

Lap the valves and seats using a rubber hose or other hand-lapping tool.



## CYLINDER HEAD/VALVES

Remove the valve and inspect the valve seat face. The valve seat contact should be within the specified width and even all around the circumference.

**STANDARD:** 1.70 mm (0.06 in)

**SERVICE LIMIT:** 2.1 mm (0.08 in)

If the seat width is not within specification, reface the valve seat (page 7-14).

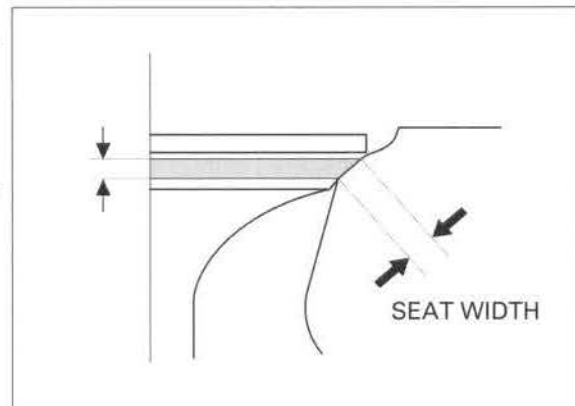

Inspect the valve seat face for:

- Uneven seat width:
  - Replace the valve and reface the valve seat.
- Damaged face:
  - Replace the valve and reface the valve seat.

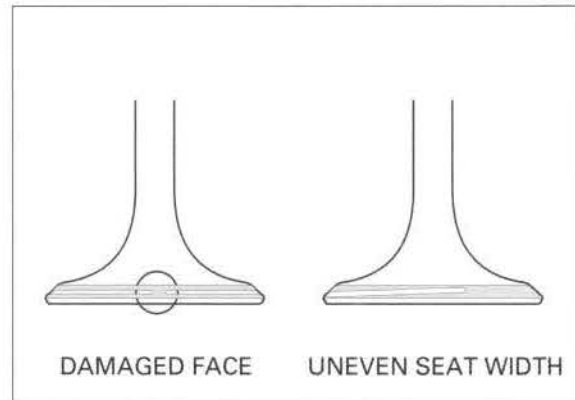

*The valves cannot be ground. If a valve face is burned or badly worn or if it contacts the seat unevenly, replace the valve.*

- Contact area (too high or too low)
  - Reface the valve seat.

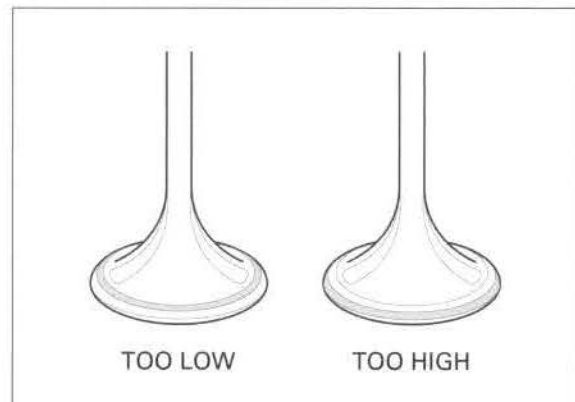

### VALVE SEAT REFACING

*Follow the refacing manufacturer's operating instructions.*

Valve seat cutters/grinders or equivalent valve seat refacing equipment are recommended to correct worn valve seats.

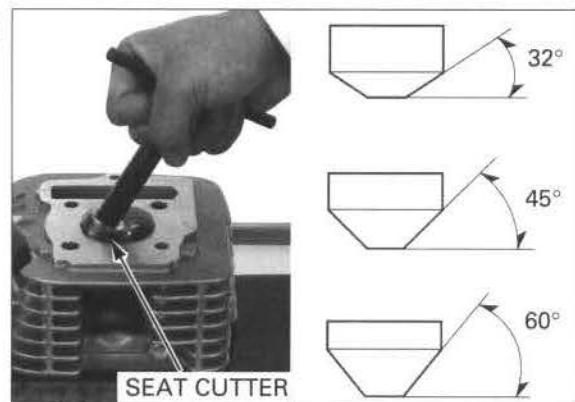

If the contact area is too high on the valve, the seat must be lowered using a 32° flat cutter.  
 If the contact area is too low on the valve, the seat must be raised using a 60° interior cutter.

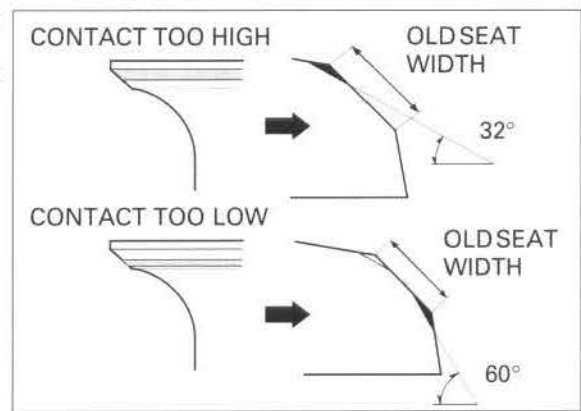

*Reface the seat with a 45-degree cutter whenever a valve guide is replaced.*

Use a 45° cutter to remove any roughness or irregularities from the seat.

**TOOLS:**

- Seat cutter, 27.5 mm (45° IN) 07780-0010200**
- Seat cutter, 24.5 mm (45° EX) 07780-0010100**
- Cutter holder, 5.5 mm 07781-0010101**
- or equivalent commercially available in U.S.A.**

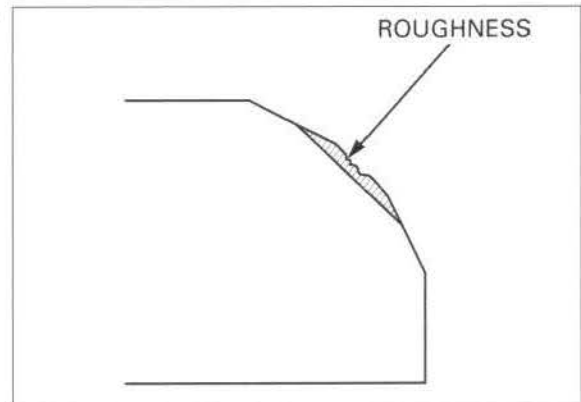

Use a 32° cutter to remove the top 1/4 of the existing valve seat material.

**TOOLS:**

- Flat cutter, 25 mm (32° IN) 07780-0012000**
- Flat cutter, 22 mm (32° EX) 07780-0012601**
- Cutter holder, 5.5 mm 07781-0010101**
- or equivalent commercially available in U.S.A.**

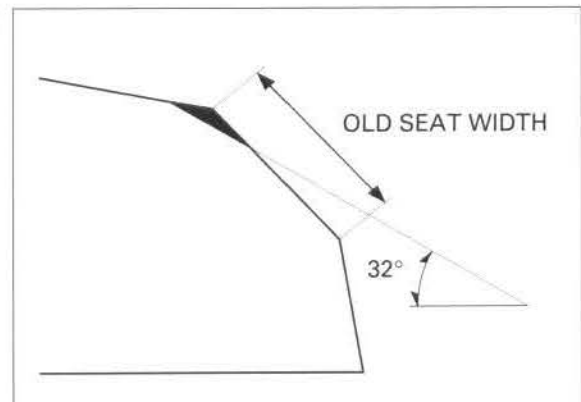

Use a 60° cutter to remove the bottom 1/4 of the old seat.

**TOOLS:**

- Interior cutter, 22 mm (60° IN/EX) 07780-0014000**
- Cutter holder, 5.5 mm 07781-0010101**
- or equivalent commercially available in U.S.A.**

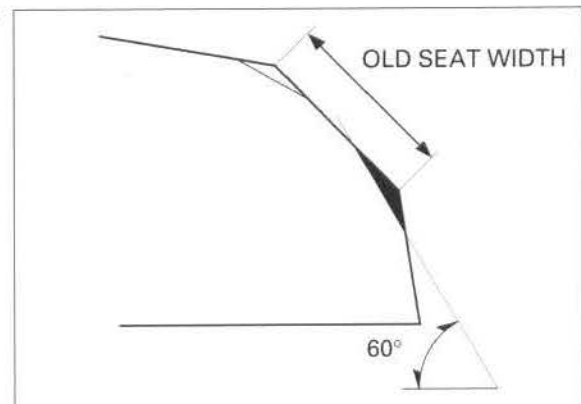

## CYLINDER HEAD/VALVES

Using a 45° seat cutter, cut the seat to the proper width.  
Make sure that all pitting and irregularities are removed.  
Refinish if necessary.

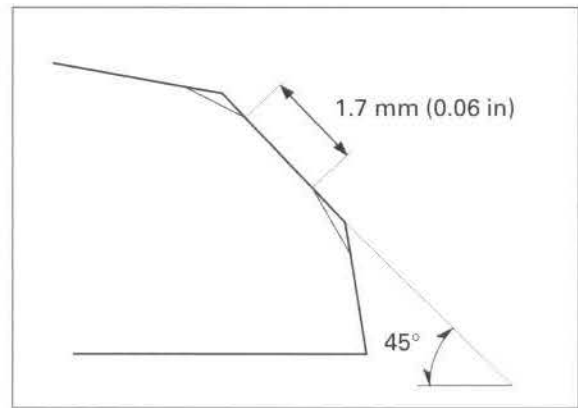

After cutting the seat, apply lapping compound to the valve face, and lap the valve using light pressure.

- Excessive lapping pressure may deform or damage the seat.
- Change the angle of lapping tool frequently to prevent uneven seat wear.
- Do not allow lapping compound to enter the guides.

After lapping, wash all residual compound off the cylinder head and valve.

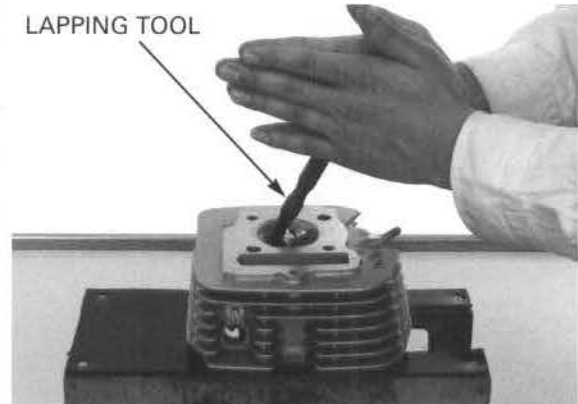

## CYLINDER HEAD ASSEMBLY

Clean the cylinder head assembly with solvent and blow out all oil passages with compressed air.

Install the valve spring seats and new stem seals.

Lubricate each valve stem and valve guide inner surface with molybdenum disulfide oil.

Install the valves into the valve guides while turning it slowly to avoid damage to the stem seal.

Install the valve springs.

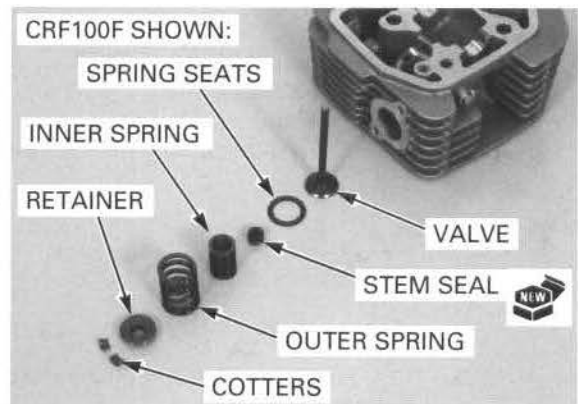

Install the valve spring retainers.

*Grease the cotters to ease installation.*

Install the valve cotters using the special tool as shown.

**NOTE:**

To prevent loss of tension, do not compress the valve spring more than necessary.

**TOOL:**

Valve spring compressor      07757-0010000



Support the cylinder head above the work bench surface to prevent possible valve damage.

Tap the valve stems gently with two plastic hammers as shown to seat the valve cotteners firmly.

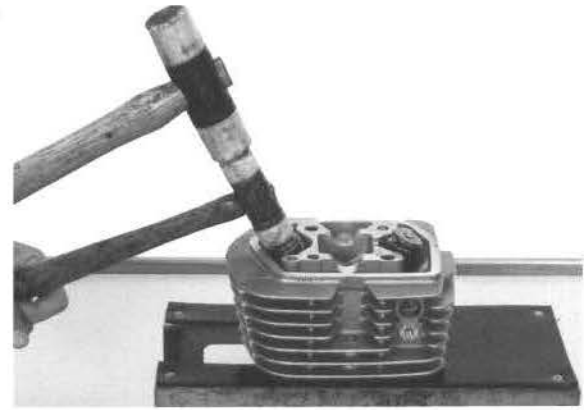

## CYLINDER HEAD INSTALLATION

Clean off any gasket material from the cylinder surface.

Install the new gasket and dowel pins.



Loosen the tensioner adjusting bolt lock nut and adjusting bolt.

Push down on the tensioner rod with a screwdriver and retighten the bolt (page 7-7).

Tighten the lock nut.

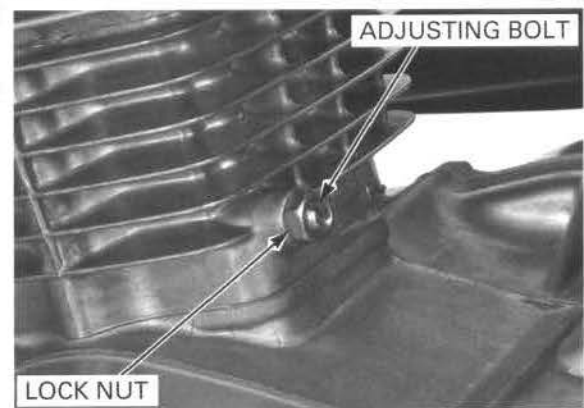

Install the cylinder head.

Install the cam chain tension adjuster with a new O-ring.

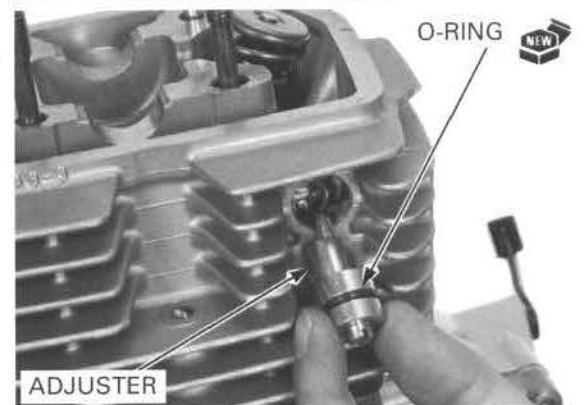

## CYLINDER HEAD/VALVES

*CRF100F:* Install the intake pipe with a new O-ring and gasket.

*CRF80F:* Install the intake pipe with a new gasket.

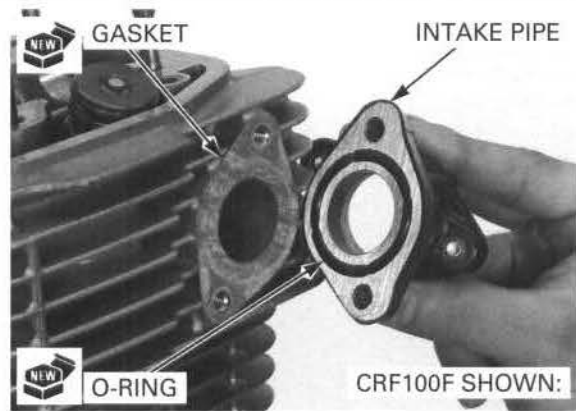

Tighten the two intake pipe bolts securely.

Install the cam chain tensioner adjuster set plate and bolt.

Install the cylinder head mounting bolt, but do not tighten.

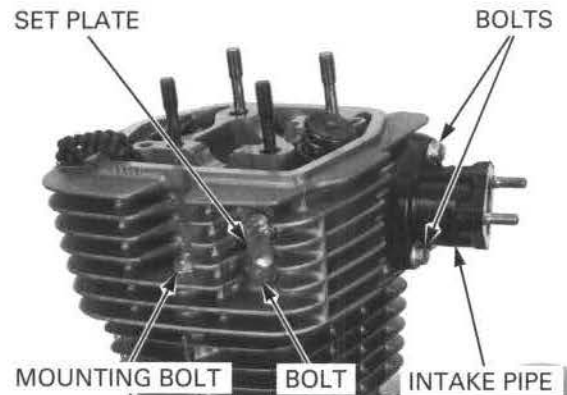

The cam chain tension adjuster has an eccentric cam to control the tension of cam chain.

To loosen the cam chain tension:

- Loosen the cam chain tension adjuster set plate bolt.
- Turn to the adjuster to the punch mark facing up.

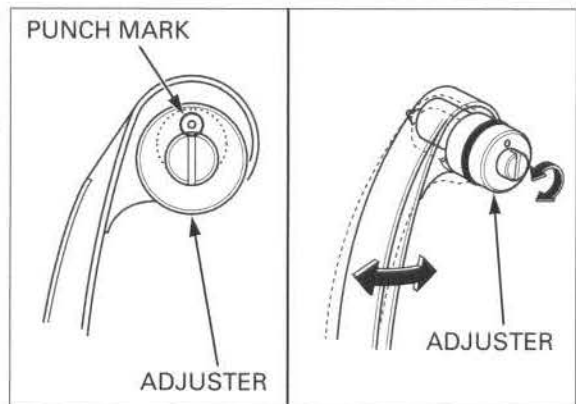

## CAMSHAFT INSTALLATION

Install the rocker arms and rocker arm shafts to the camshaft holder.

Align the cutout of the intake rocker arm shaft with the bolt hole as shown.

Push the exhaust rocker arm shaft in completely.

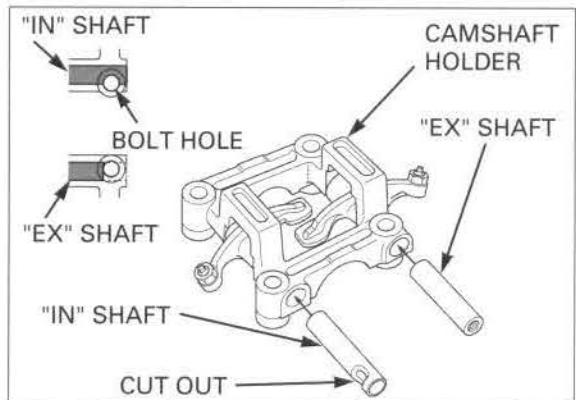



Coat the camshaft journals with molybdenum disulfide grease.

Install the cam sprocket to the camshaft with its "O" mark facing up and camshaft lobes facing down.

Install the dowel pins.

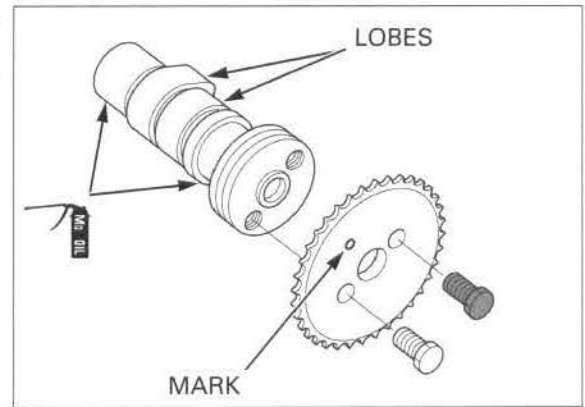

Make sure that the cam chain tension adjuster is set to the loosen setting (page 7-18).

Turn the crankshaft counterclockwise and align the "T" mark on the flywheel with the index mark on the left crankcase.

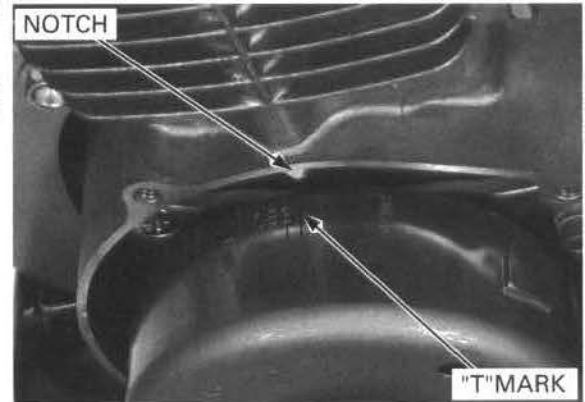

Install the cam chain onto the cam sprocket with cam sprocket bolt holes in parallel to the cylinder head surface and "O" mark facing up.

Install the camshaft holder assembly and washers over the cylinder head, then tighten the camshaft holder mounting nuts to the specified torque.

**TORQUE: 20 N·m (2.0 kgf·m, 14 lbf·ft)**

Tighten the cylinder head mounting bolt.

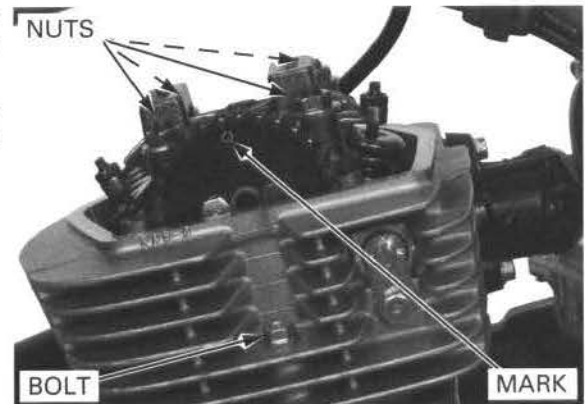

*Install the dowel bolt (black) on the intake side.*

Tighten the cam sprocket bolts to the specified torque.

**TORQUE: 12 N·m (1.2 kgf·m, 9 lbf·ft)**

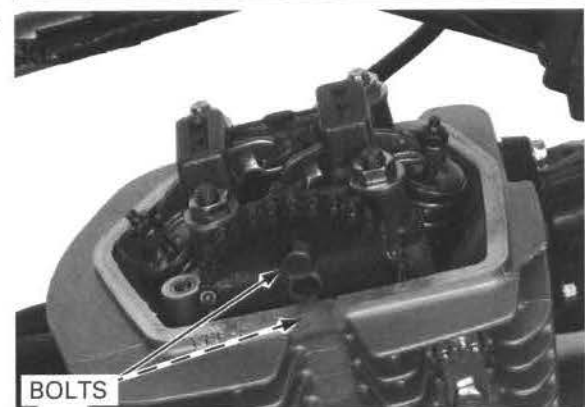

## CYLINDER HEAD/VALVES

Loosen the lock nut and adjusting bolt.

The cam chain adjuster sets automatically when the adjusting bolt is loosened.

*When tightening the lock nut, hold the adjusting bolt to prevent it from turning with the lock nut.*

After adjustment, tighten the lock nut to the specified torque.

**TORQUE: 12 N·m (1.2 kgf·m, 9 lbf·ft)**

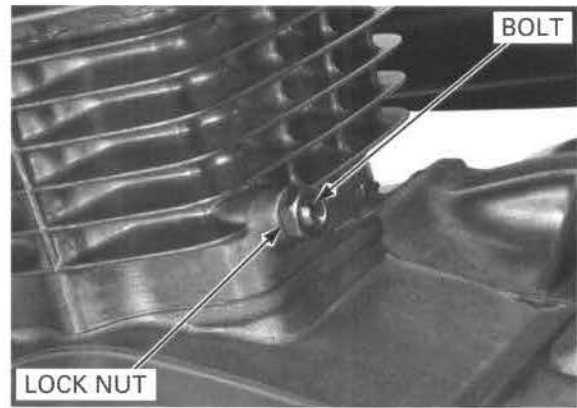

Pour clean engine oil into the cylinder head oil pocket.

Adjust the valve clearance (page 3-12).

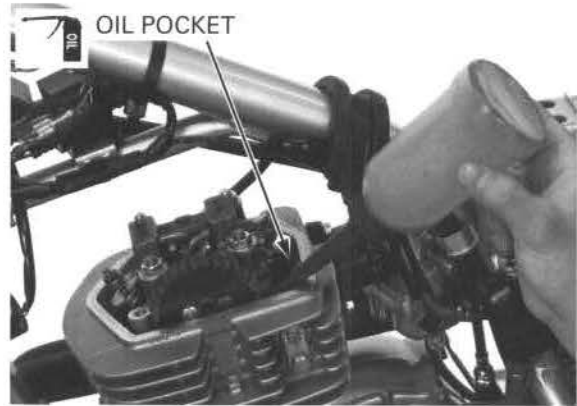

Install a new gasket into the groove of the cylinder head cover.



Install the cylinder head cover and new mounting rubbers then tighten the two bolts to the specified torque.

**TORQUE: 12 N·m (1.2 kgf·m, 9 lbf·ft)**

Install the following:

- Left crankcase cover (page 10-8)
- Fuel tank (page 2-4)
- Seat (page 2-3)
- Side cover (page 2-3)

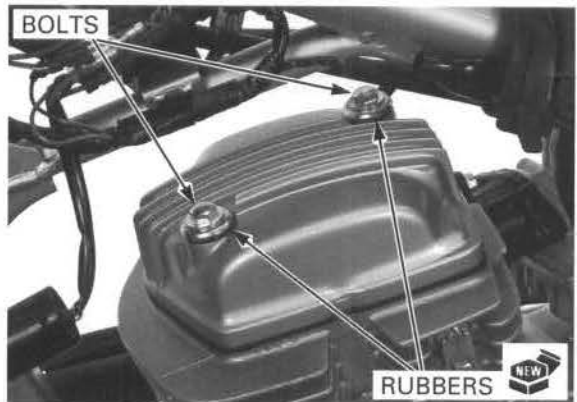

*Do not run the engine at high-speed. This will prevent engine damage, if the oil passages is clogged.*

Start the engine and let it idle.

Check the cam chain tension (page 3-15), adjust if necessary.

Loosen, but do not remove, the cylinder head oil check bolt and make sure oil flows from the oil check bolt hole.

If do not flow the engine oil from the oil check bolt hole, inspect the related oil passage clogging.

Retighten the oil check bolt and check for no oil leaks.

If the engine oil leaks from the oil check bolt hole, stop the engine and replace the sealing washer with a new one.

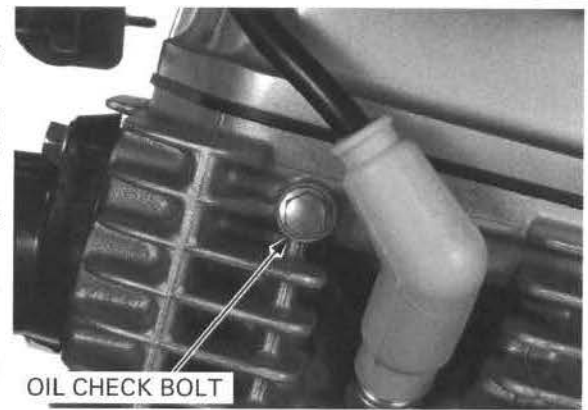

# 8. CYLINDER/PISTON

---

COMPONENT LOCATION .....	8-2	PISTON REMOVAL .....	8-6
SERVICE INFORMATION .....	8-3	PISTON/PISTON RING INSPECTION.....	8-7
TROUBLESHOOTING .....	8-4	PISTON INSTALLATION .....	8-9
CYLINDER REMOVAL .....	8-5	CYLINDER INSTALLATION.....	8-10
CYLINDER INSPECTION.....	8-5		

COMPONENT LOCATION

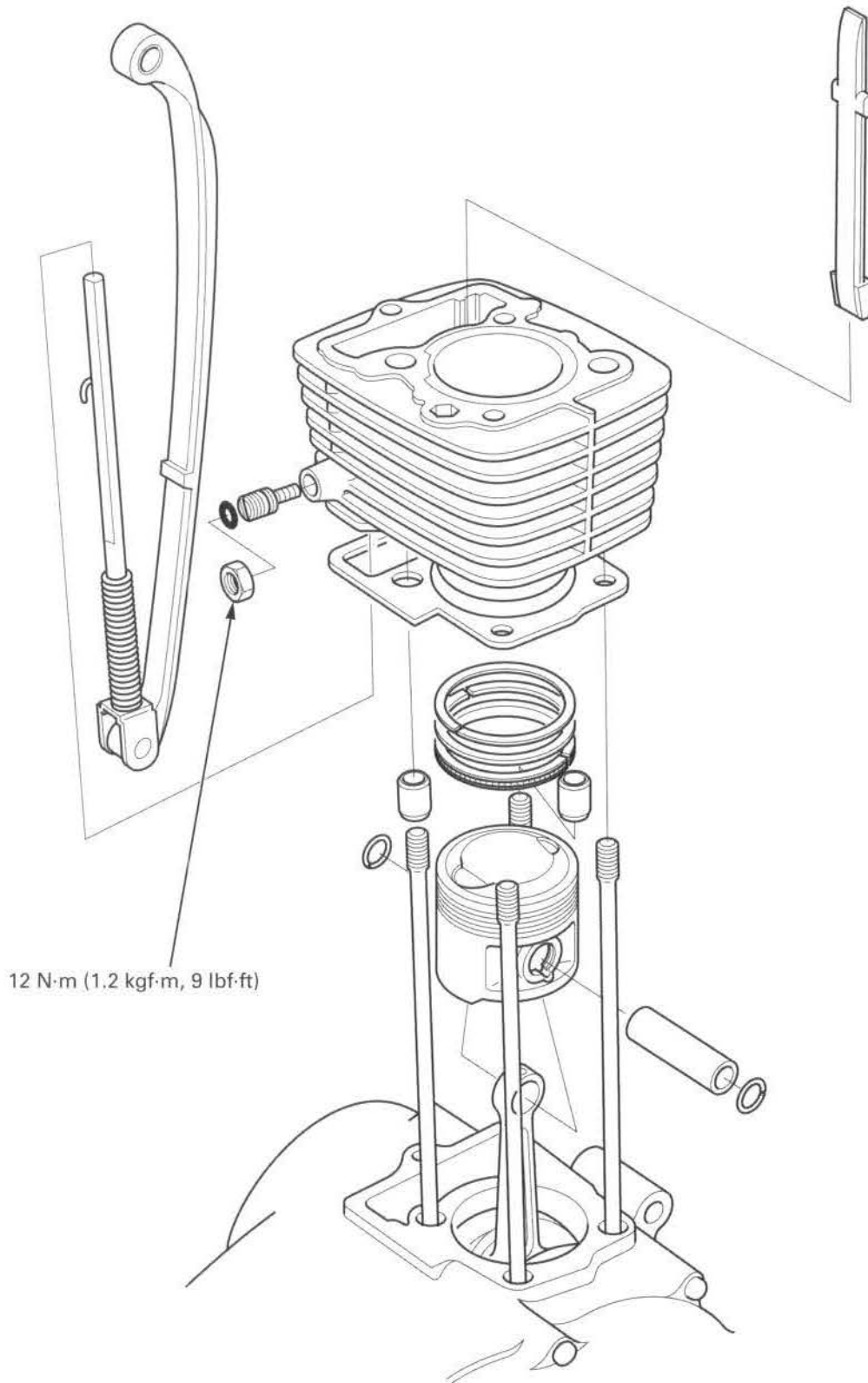

## SERVICE INFORMATION

### GENERAL

- The engine must be removed from the frame to perform the operations in this section.
- Camshaft lubricating oil is fed to the cylinder head through an orifice in the cylinder head, cylinder and crankcase. Be sure that this orifice is not clogged and that the O-rings and dowel pins are in place before installing the cylinder.
- Clean all disassembled parts with cleaning solvent and dry them by blowing them off with compressed air before inspection.

### SPECIFICATIONS (CRF100F)

Unit: mm (in)

ITEM		STANDARD	SERVICE LIMIT	
Cylinder	I.D.	53.000 – 53.010 (2.0866 – 2.0870)	53.1 (2.09)	
	Taper	–	0.10 (0.004)	
	Out of round	–	0.10 (0.004)	
	Warpage	–	0.10 (0.004)	
Piston, piston ring	Piston mark direction	"IN" mark facing toward the intake side	–	
	Piston O.D.	52.960 – 52.990 (2.0850 – 2.0862)	52.90 (2.083)	
	Piston O.D. measurement point	10 mm(0.4 in) from the bottom of skirt	–	
	Piston pin bore I.D.	14.002 – 14.008 (0.5513 – 0.5515)	14.04 (0.553)	
	Piston pin O.D.	13.994 – 14.000 (0.5509 – 0.5512)	13.96 (0.550)	
	Piston-to-piston pin clearance	0.002 – 0.014 (0.0001 – 0.0006)	0.020 (0.0008)	
	Piston ring to ring groove clearance	Top	0.015 – 0.045 (0.0006 – 0.0018)	0.10 (0.004)
		Second	0.015 – 0.045 (0.0006 – 0.0018)	0.10 (0.004)
	Piston ring end gap	Top ring	0.05 – 0.20 (0.002 – 0.008)	0.4 (0.02)
		Second ring	0.05 – 0.20 (0.002 – 0.008)	0.4 (0.02)
Oil ring (side rail)		0.20 – 0.70 (0.01 – 0.03)	0.9 (0.04)	
Cylinder-to-piston clearance		0.010 – 0.050 (0.0004 – 0.0020)	0.10 (0.004)	
Connecting rod small end I.D.		14.012 – 14.030 (0.5517 – 0.5523)	14.05 (0.553)	
Connecting rod-to-piston pin clearance		0.016 – 0.040 (0.0006 – 0.0016)	0.09 (0.003)	

### SPECIFICATIONS (CRF80F)

Unit: mm (in)

ITEM		STANDARD	SERVICE LIMIT	
Cylinder	I.D.	47.500 – 47.510 (1.8701 – 1.8705)	47.6 (1.87)	
	Taper	–	0.10 (0.004)	
	Out of round	–	0.10 (0.004)	
	Warpage	–	0.10 (0.004)	
Piston, piston ring	Piston mark direction	"EX" mark facing toward the exhaust side	–	
	Piston O.D.	47.465 – 47.490 (1.8686 – 1.8697)	47.40 (1.866)	
	Piston O.D. measurement point	7 mm(0.3 in) from the bottom of skirt	–	
	Piston pin bore I.D.	13.002 – 13.008 (0.5119 – 0.5121)	13.04 (0.513)	
	Piston pin O.D.	12.994 – 13.000 (0.5116 – 0.5118)	12.96 (0.510)	
	Piston-to-piston pin clearance	0.002 – 0.014 (0.0001 – 0.0006)	0.020 (0.0008)	
	Piston ring to ring groove clearance	Top	0.015 – 0.045 (0.0006 – 0.0018)	0.10 (0.004)
		Second	0.015 – 0.045 (0.0006 – 0.0018)	0.10 (0.004)
	Piston ring end gap	Top ring	0.10 – 0.25 (0.004 – 0.010)	0.4 (0.02)
		Second ring	0.10 – 0.25 (0.004 – 0.010)	0.4 (0.02)
Oil ring (side rail)		0.20 – 0.70 (0.01 – 0.03)	0.9 (0.04)	
Cylinder-to-piston clearance		0.010 – 0.045 (0.0004 – 0.0018)	0.10 (0.004)	
Connecting rod small end I.D.		13.016 – 13.034 (0.5124 – 0.5131)	13.04 (0.513)	
Connecting rod-to-piston pin clearance		0.016 – 0.040 (0.0006 – 0.0016)	0.09 (0.003)	

## TROUBLESHOOTING

- If the performance is poor at low speeds, check for white smoke in the crankcase breather hose. If the hose is smoky, check for a seized piston ring.

### **Cylinder compression is too low, or engine is hard to start**

- Brown cylinder head gasket
- Worn, stuck or broken piston ring
- Worn or damaged cylinder or piston

### **Cylinder compression is too high, or engine overheats**

- Excessive carbon build-up on the piston head or combustion chamber

### **Knocking or abnormal noise**

- Worn cylinder, piston and/or piston ring
- Excessive carbon build-up
- Worn piston pin hole and piston pin
- Worn connecting rod small end

### **Excessive smoke**

- Worn cylinder, piston or piston rings
- Improper installation of piston rings
- Scored or scratched piston or cylinder wall

## CYLINDER REMOVAL

Remove the cylinder head (page 7-10).

*Prevent the cam chain from falling into the crankcase when removing the cylinder.*

Remove the cam chain guide.

Remove the cylinder.

Remove the cylinder gasket and dowel pins.

Loosen the lock nut and remove the adjusting bolt.

Remove the cam chain tensioner and spring.

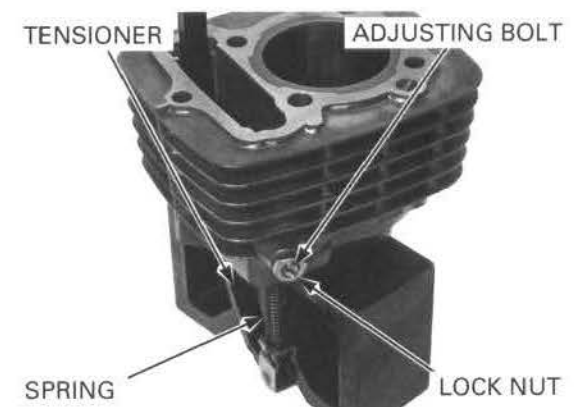
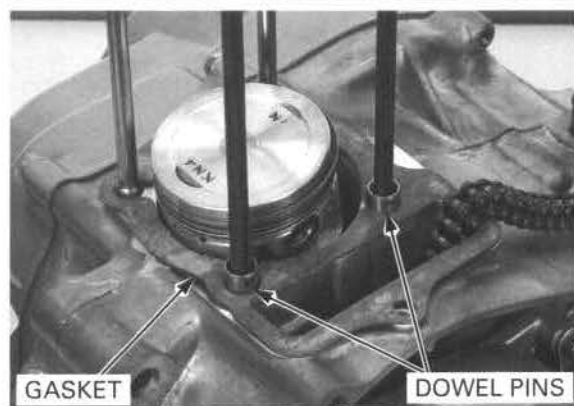
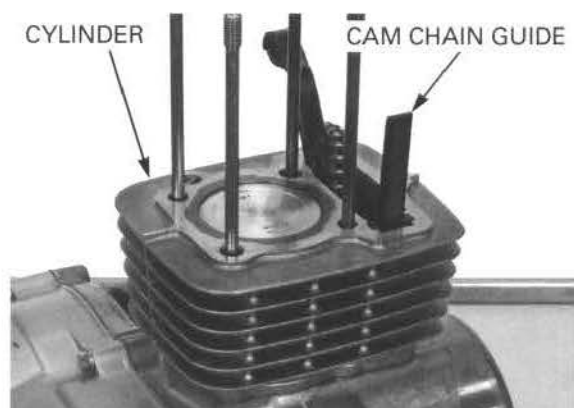

## CYLINDER INSPECTION

Inspect the cylinder bore for scratches or wear.

Measure the cylinder I.D. at three levels in an X and Y axis.

Take the maximum reading to determine the cylinder wear.

### SERVICE LIMITS:

**CRF100F:** 53.1 mm (2.09 in)

**CRF80F:** 47.6 mm (1.87 in)

Calculate the piston-to-cylinder clearance.

Take a maximum reading to determine the clearance.

Refer to page 8-7 for measurement of the piston O.D.

**SERVICE LIMIT:** 0.10 mm (0.004 in)

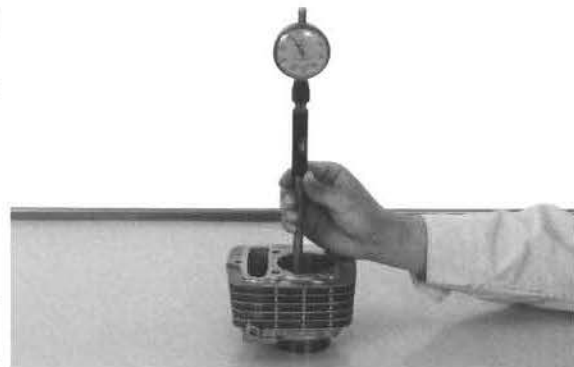



## CYLINDER/PISTON

Calculate the cylinder for taper and out of round at three levels in an X and Y axis. Take the maximum reading to determine the taper and out of round.

### SERVICE LIMITS:

**Taper: 0.10 mm (0.004 in)**

**Out-of-round: 0.10 mm (0.004 in)**

The cylinder must be rebored and an oversize piston fitted if the service limits are exceeded.

The following oversize pistons are available:

CRF100F:	0.25 mm (0.010 in)
	0.50 mm (0.020 in)
CRF80F:	0.25 mm (0.010 in)
	0.50 mm (0.020 in)
	0.75 mm (0.030 in)
	1.00 mm (0.039 in)

The piston-to-cylinder clearance for the oversize piston must be: 0.010 – 0.040 mm (0.0004 – 0.0016 in)

Inspect the top of the cylinder for warpage by placing a straight edge and a feeler gauge.

**SERVICE LIMIT: 0.10 mm (0.004 in)**

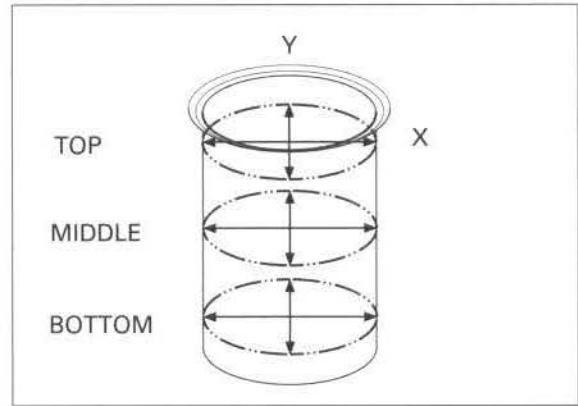

## PISTON REMOVAL

Place clean shop towels in the crankcase to keep the piston pin clips, or other parts from falling into the crankcase.

Remove the piston pin clip with pliers.

Remove the piston pin out, and then remove the piston.

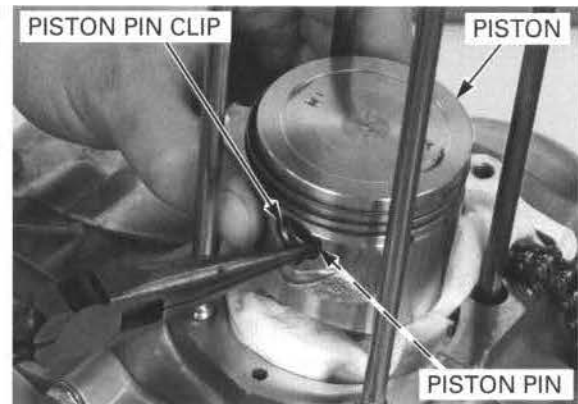

**PISTON RING REMOVAL**

*Do not damage the piston rings by spreading the ends too far.*

Spread each piston ring and remove it by lifting it up at a point opposite the gap.

PISTON RING

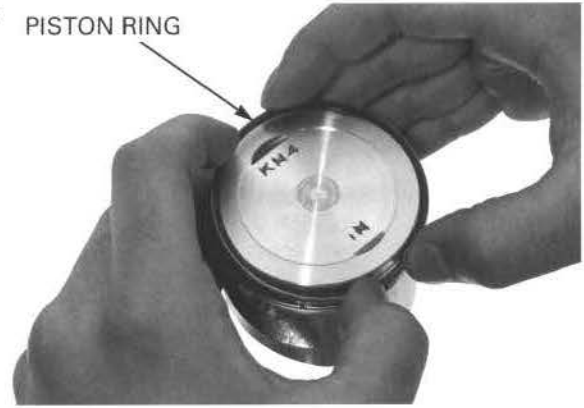

**PISTON/PISTON RING INSPECTION**

Remove any carbon deposits from the piston ring grooves, using the old piston ring as shown.

Inspect the piston for damage.



Temporarily install the piston rings to their proper position with the mark facing up.

Measure the piston ring-to-ring groove clearance with the rings pushed into the grooves.

**SERVICE LIMITS:**

- Top: 0.10 mm (0.004 in)
- Second: 0.10 mm (0.004 in)

Inspect the piston ring grooves for wear or damage.



*Measure the piston diameter perpendicular to the piston pin hole.*

Measure the piston diameter at specification given from the bottom and 90 degrees to the piston pin hole.

**PISTON O.D. MEASUREMENT POINTS:**

- CRF100F: 10 mm (0.4 in)
- CRF80F: 7 mm (0.3 in)

**SERVICE LIMITS:**

- CRF100F: 52.90 mm (2.083 in)
- CRF80F: 47.40 mm (1.866 in)

Calculate the cylinder-to-piston clearance (cylinder I.D.; See page 8-5).

**SERVICE LIMIT: 0.10 mm (0.004 in)**



## CYLINDER/PISTON

Measure and record the piston pin bore I.D.

**SERVICE LIMITS:**

**CRF100F:** 14.04 mm (0.553 in)  
**CRF80F:** 13.04 mm (0.513 in)

Measure and record the piston pin O.D. at three points.

**SERVICE LIMITS:**

**CRF100F:** 13.96 mm (0.550 in)  
**CRF80F:** 12.96 mm (0.510 in)

Calculate the piston-to-piston pin clearance by subtracting the piston pin O.D. from the piston pin bore I.D.

**SERVICE LIMIT:** 0.020 mm (0.0008 in)

Measure and record the connecting rod small end I.D.

**SERVICE LIMITS:**

**CRF100F:** 14.05 mm (0.553 in)  
**CRF80F:** 13.04 mm (0.513 in)

Calculate the connecting rod-to-piston pin clearance by subtracting the piston pin O.D. from the connecting rod small end I.D.

**SERVICE LIMIT:** 0.09 mm (0.003 in)



*Push the rings into the cylinder with the top of the piston to be sure they are squarely in the cylinder.*

Insert the piston ring squarely into the bottom of the cylinder and measure the ring end gap.

**SERVICE LIMITS:**

**Top:** 0.4 mm (0.02 in)  
**Second:** 0.4 mm (0.02 in)  
**Oil (side rail):** 0.9 mm (0.04 in)

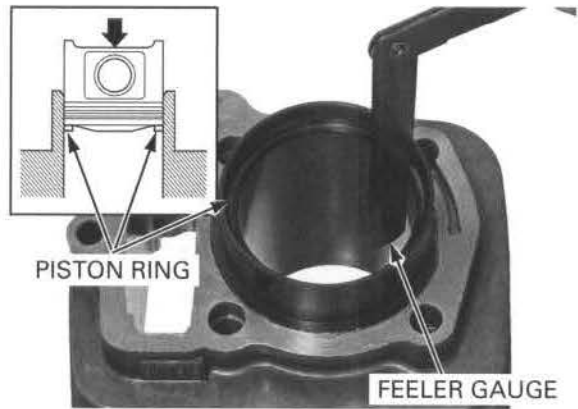

# PISTON INSTALLATION

## PISTON RING INSTALLATION

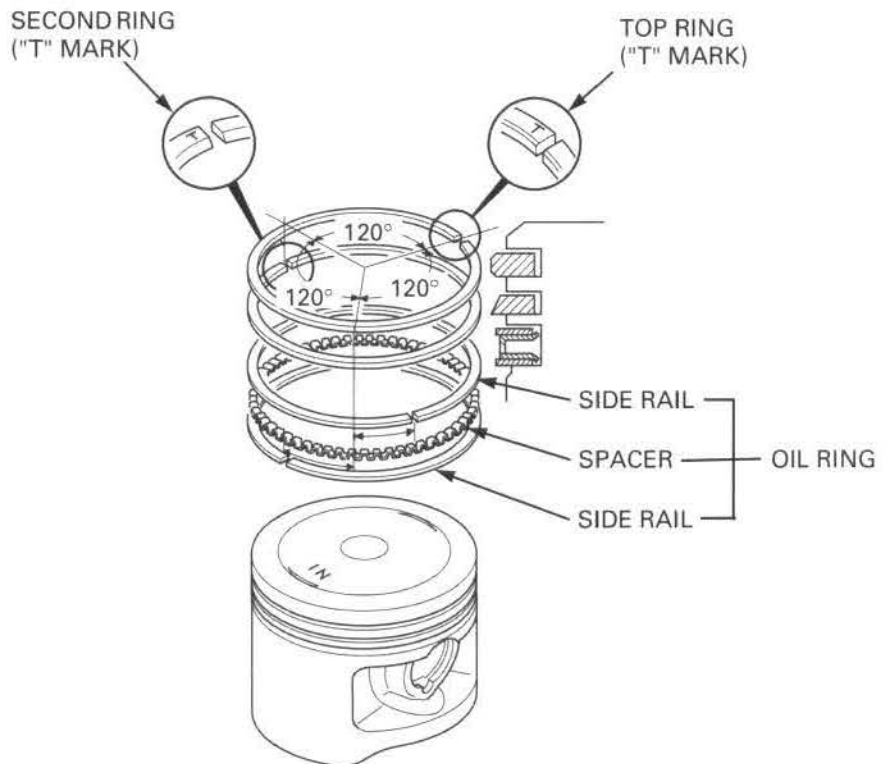

CRF100F SHOWN:

Clean the piston ring grooves thoroughly and install the piston rings.

- Apply oil to the piston rings.
- Avoid piston and piston ring damage during installation.
- Install the piston rings with the marking facing up.

### EACH PISTON RING MARK TABLE:

	TOP RING	SECOND RING
CRF100F	T	T
CRF80F	R	RN

- Do not mix the top and second rings.
- To install the oil ring, install the spacer first, then install the side rails.

Do not align the gaps in the oil rings (side rails).

Space the piston ring end gaps 120 degrees apart.

After installation, the piston rings should rotate freely in the piston ring grooves.

## CYLINDER/PISTON

### PISTON INSTALLATION

Place a clean shop towel over the crankcase to prevent the gasket material, piston pin clip or other parts falling into the crankcase.

*Be careful not to damage the gasket mating surface.*

Clean the gasket surface of the crankcase thoroughly

Apply molybdenum oil solution to the connecting rod small end inner surfaces and piston pin outer surfaces.

Install the piston and piston pin, using a new piston pin clip.

Remove the shop towel.

- CRF100F:**
- Install the piston with its "IN" mark facing the intake side.
- CRF80F:**
- Install the piston with its "EX" mark facing the exhaust side.
  - Make sure that the piston pin clips are seated securely.
  - Do not align the piston pin clip's end gap with the piston cut-out.
  - Do not let the clip fall into the crankcase.

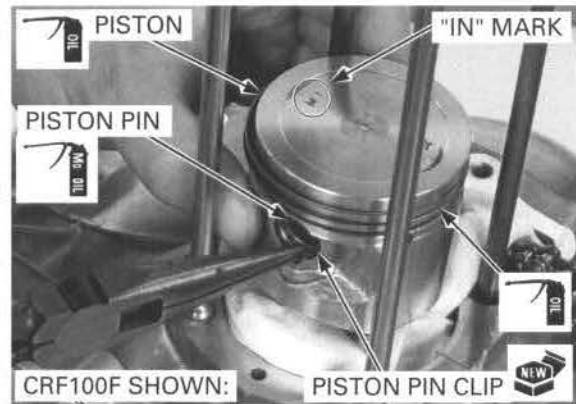

### CYLINDER INSTALLATION

Install the cam chain tensioner rod into the hole in the cylinder and hook the spring end on the cylinder spring groove.

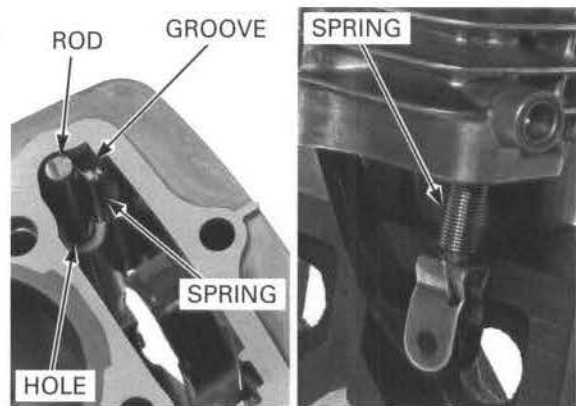

Install a new O-ring on the cam chain tensioner adjusting bolt and lock nut.

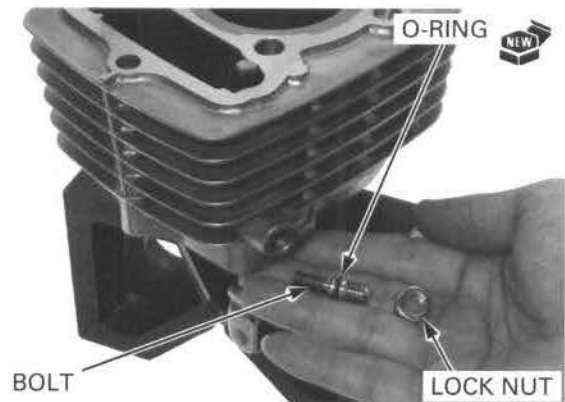

Pull the tensioner down, then tighten the adjusting bolt and lock nut.

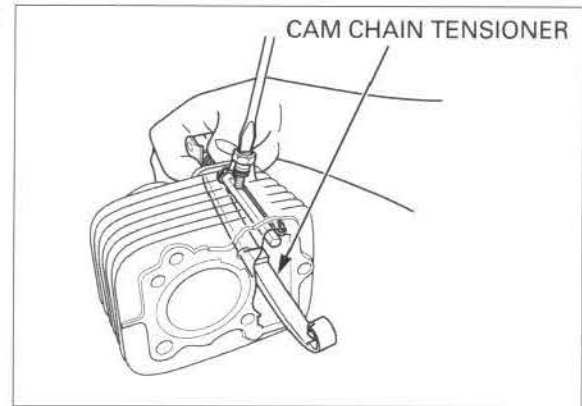

Clean off any gasket materials from the crankcase surface.

Install the dowel pins and new gasket.

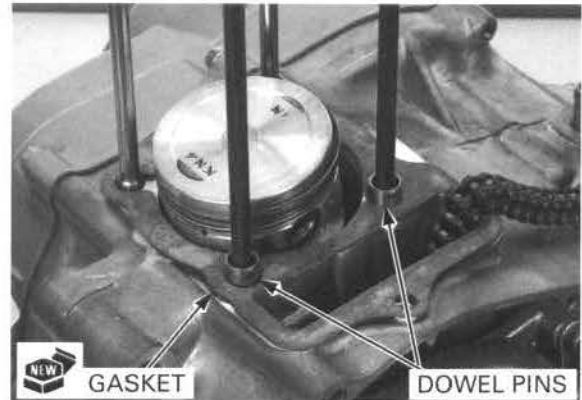

*Do not let the cam chain fall into the crankcase.*

Coat the cylinder bore, piston outer surface and piston ring grooves with clean engine oil.

Install the cylinder while compressing the piston rings.

Avoid piston ring damage during installation.

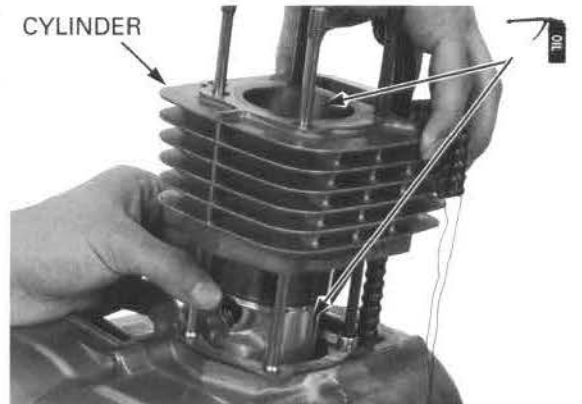

*Do not let the cam chain fall into the crankcase.*

Install the cam chain guide.

Install the following:

- Cylinder head (page 7-17)
- Camshaft (page 7-18)
- Cylinder head cover (page 7-20)
- Carburetor (page 5-15)
- Engine (page 6-7)
- Seat, side cover (page 2-3)

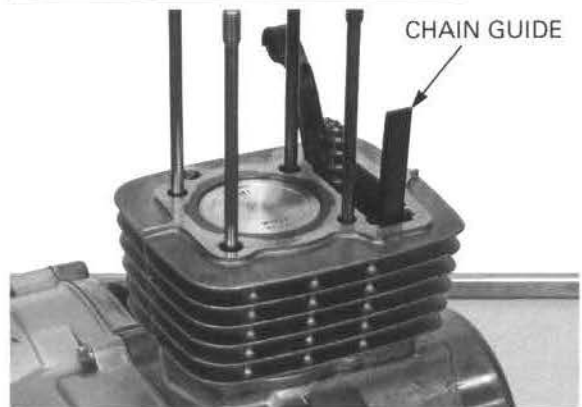

# 9. CLUTCH/GEARSHIFT LINKAGE

---

COMPONENT LOCATION .....	9-2	CLUTCH .....	9-7
SERVICE INFORMATION .....	9-3	PRIMARY DRIVE GEAR.....	9-10
TROUBLESHOOTING .....	9-4	GEARSHIFT LINKAGE.....	9-12
RIGHT CRANKCASE COVER REMOVAL...	9-5	RIGHT CRANKCASE COVER INSTALLATION .....	9-14

COMPONENT LOCATION

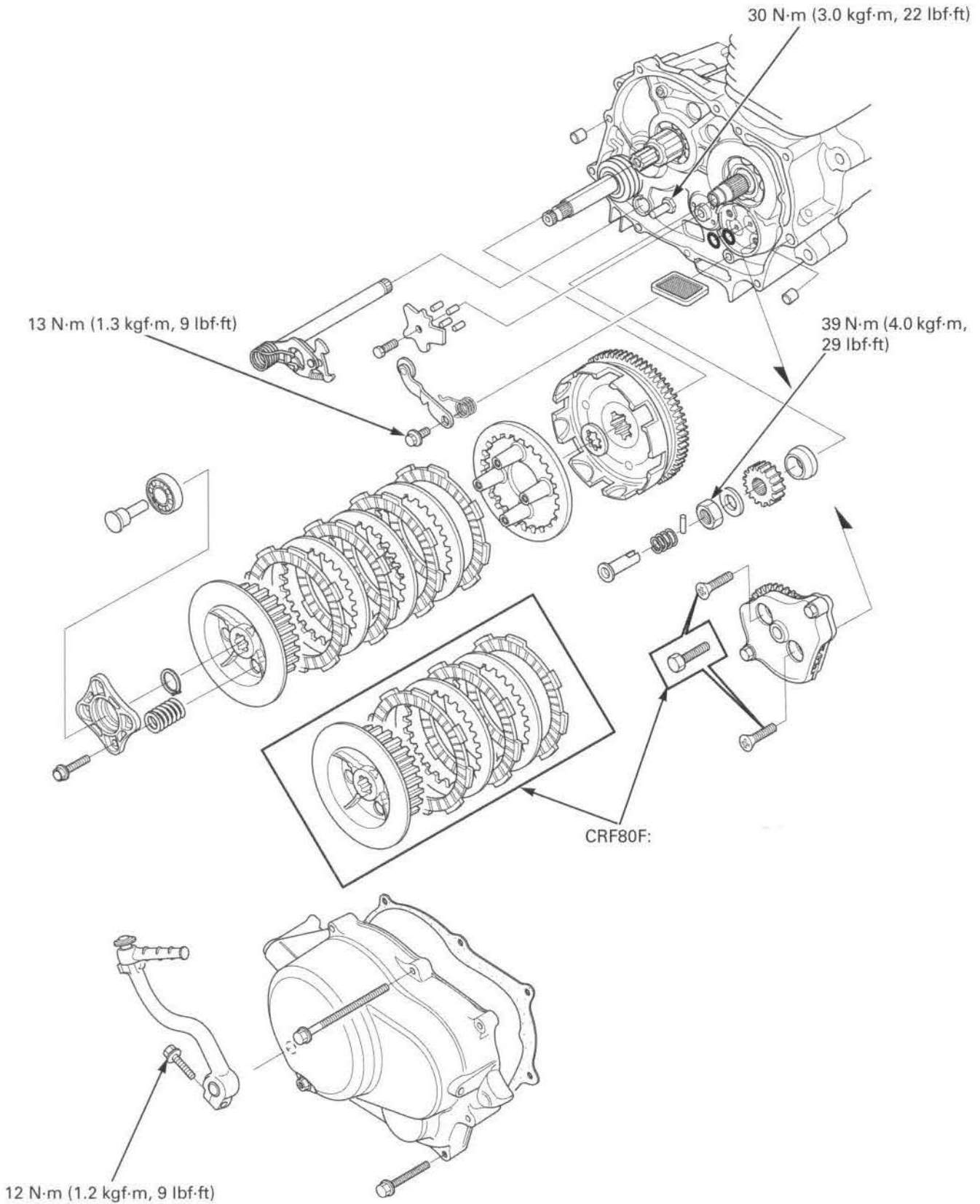



## SERVICE INFORMATION

### GENERAL

- This section covers maintenance of the clutch, gearshift linkage and right crankcase cover. These services can be performed with the engine installed in the frame.

### SPECIFICATIONS

ITEM		STANDARD	SERVICE LIMIT
Clutch lever free play		10 – 20 (3/8 – 3/4)	–
Clutch spring free length	CRF100F	31.9 (1.25)	29.5 (1.16)
	CRF80F	27.6 (1.09)	25.5 (1.00)
Clutch disc thickness	CRF100F	2.92 – 3.08 (0.115 – 0.121)	2.7 (0.11)
	CRF80F	2.90 – 3.00 (0.114 – 0.118)	2.5 (0.10)
Clutch plate warpage		–	0.20 (0.008)

Unit: mm (in)

### TORQUE VALUES

Primary drive gear lock nut	39 N·m (4.0 kgf·m, 29 lbf·ft)
Stopper arm pivot bolt	13 N·m (1.3 kgf·m, 9 lbf·ft)
Shift return spring pin	30 N·m (3.0 kgf·m, 22 lbf·ft)
Foot peg mounting bolt	55 N·m (5.6 kgf·m, 41 lbf·ft)
Kickstarter pedal pinch bolt	12 N·m (1.2 kgf·m, 9 lbf·ft)

Apply oil to the threads and seating surface.

### TOOL

Gear holder, M1.5  
07724-0010200



or 07724-001A200 (U.S.A. only)

### TROUBLESHOOTING

Faulty clutch operation can usually be corrected by adjusting the clutch lever free play.

#### **Clutch lever hard to pull in**

- Damaged, kinked or dirty clutch cable
- Improperly routed clutch cable
- Damaged clutch lifter mechanism
- Faulty clutch lifter plate bearing

#### **Clutch will not disengage or motorcycle creeps with clutch disengaged**

- Too much clutch lever free play
- Clutch plate warped
- Oil level too high, improper oil viscosity, or additive used

#### **Clutch slips**

- Clutch lifter sticking
- Worn clutch discs
- Weak clutch springs
- No clutch lever free play
- Check for oil additive

#### **Hard to shift**

- Misadjusted clutch cable
- Damaged or bent shift fork
- Bent shift fork shaft
- Incorrect engine oil viscosity
- Incorrect gearshift spindle assembly
- Damaged shift drum cam grooves

#### **Transmission jumps out of gear**

- Worn shift drum stopper arm
- Worn or broken gearshift spindle return spring
- Bent shift fork shaft
- Damaged shift drum cam grooves
- Worn gear dogs or slots

#### **Gearshift pedal will not return**

- Weak or broken gearshift spindle return spring
- Bent gearshift spindle

**RIGHT CRANKCASE COVER REMOVAL**

Drain the engine oil (page 3-13).  
Remove the bolt and kick starter pedal.

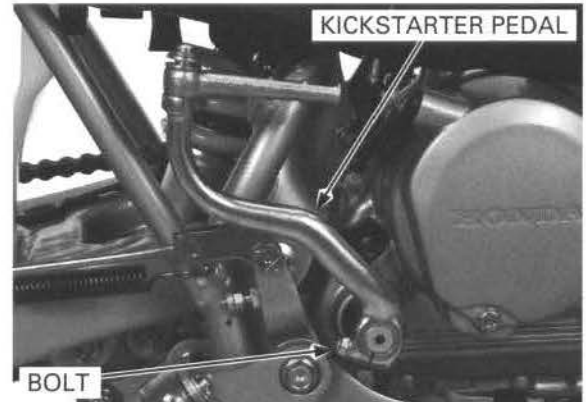

Disconnect the clutch cable.

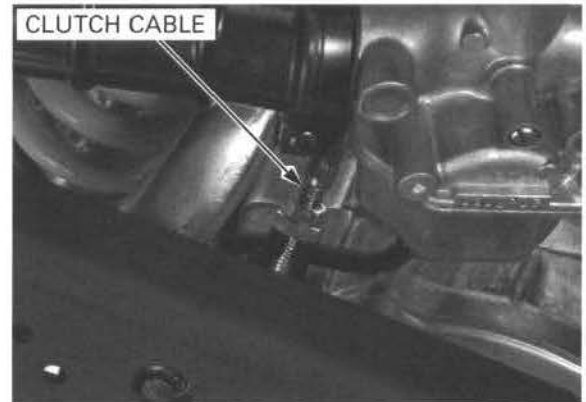

Remove the two bolts and right foot peg.

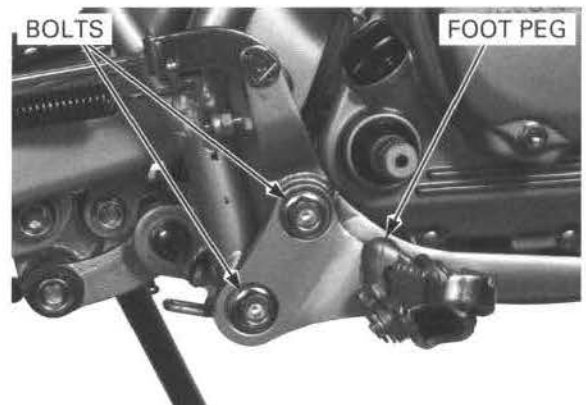

*Loosen the right crankcase cover bolt in a crisscross pattern in 2 – 3 steps.* Remove the nine bolts and right crankcase cover.

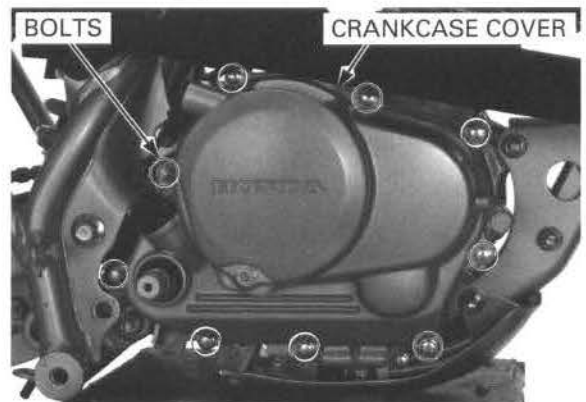

## CLUTCH/GEARSHIFT LINKAGE

Remove the gasket and dowel pins.

Remove the oil strainer screen and clean it (page 3-15).

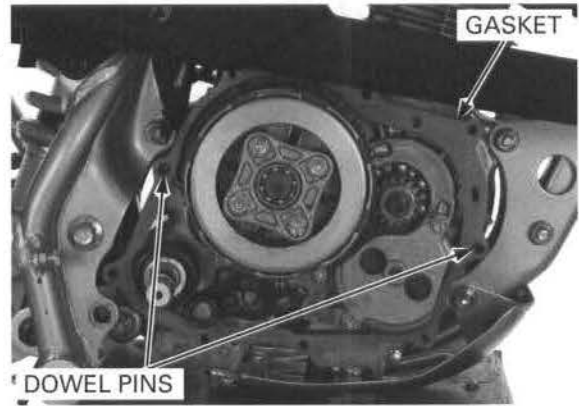

### DISASSEMBLY

Remove the clutch adjusting screw lock nut.

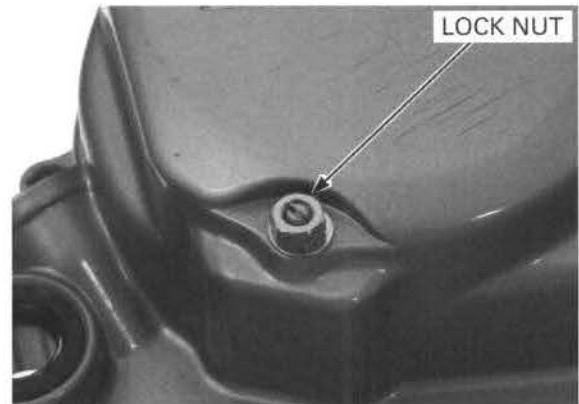

Remove the clutch adjusting lever, O-ring and clutch adjusting screw.

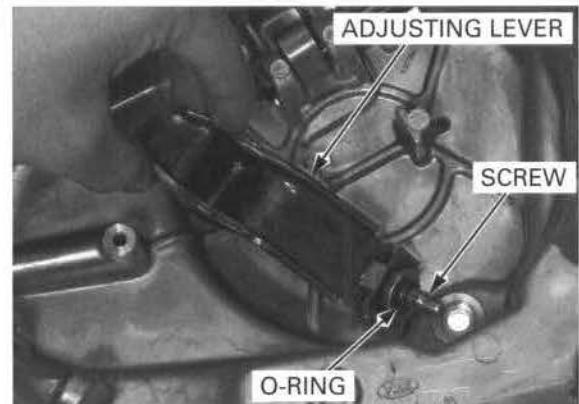

Remove the following:

- Cotter pin
- Clutch lifter cam
- Clutch lever spring
- Clutch lever
- O-ring

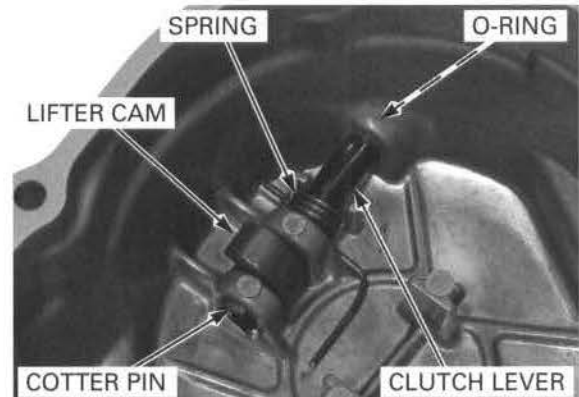

# CLUTCH

## REMOVAL

Remove the following:

- Clutch lifter pin
- Clutch spring bolts
- Clutch lifter plate
- Clutch springs

*Loosen the clutch spring bolts in a crisscross pattern in 2-3 steps.*

- Snap ring
- Clutch center
- Clutch discs
- Clutch plates
- Clutch pressure plate

- Spline washer
- Clutch outer

## INSPECTION

### Clutch lifter bearing

Turn the inner race of the lifter bearing with your finger.

The bearing should turn smoothly and freely without excessive play.

Also check that the bearing fits tightly in the clutch outer cover.

If necessary replace the bearing.

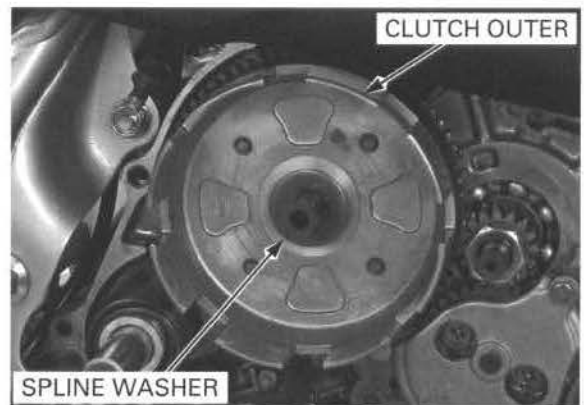
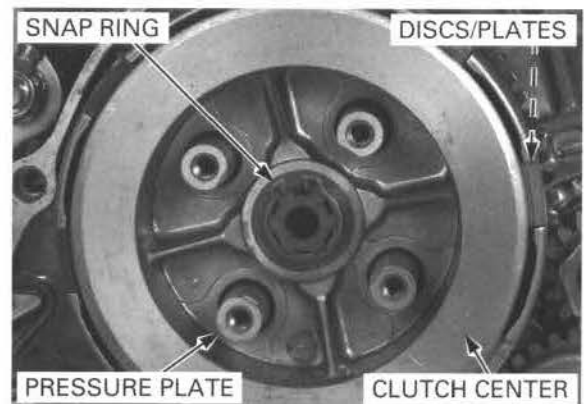
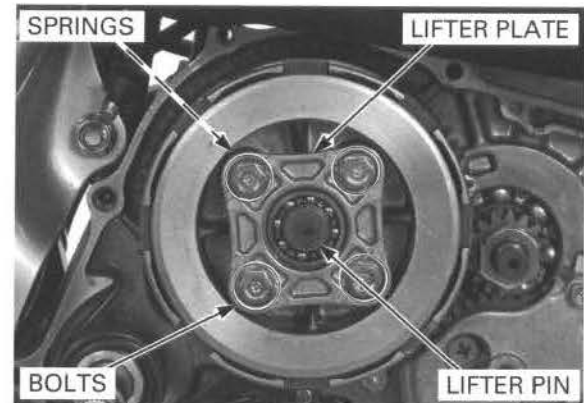

LIFTER PLATE



LIFTER BEARING

## CLUTCH/GEARSHIFT LINKAGE

### Clutch spring

Measure the clutch spring free length.

#### SERVICE LIMITS:

- CRF100F: 29.5 mm (1.16 in)
- CRF80F: 25.5 mm (1.00 in)

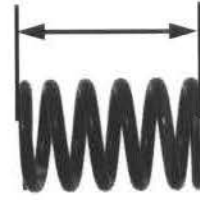

### Clutch disc

*Replace the clutch discs and plates as a set.*

Replace the clutch discs if they show signs of scoring or discoloration.

Measure the thickness of each disc.

#### SERVICE LIMITS:

- CRF100F: 2.7 mm (0.11 in)
- CRF80F: 2.5 mm (0.10 in)



### Clutch plate

*Replace the clutch discs and plates as a set.*

Check the plates for discoloration.

Check each clutch plate for warpage on a surface plate using a feeler gauge.

#### SERVICE LIMIT: 0.20 mm (0.008 in)

- Warped clutch plates prevents the clutch from disengaging properly.
- Clutch plates should be replaced as a set.

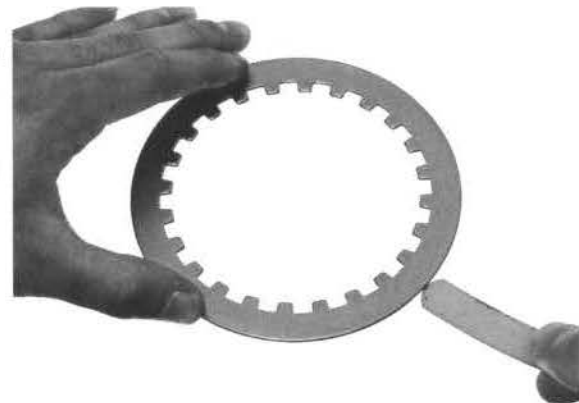

### Clutch outer

Check the slots in the clutch outer for nicks, cuts or damage caused by the clutch discs.

Check the gear teeth of the primary driven gear for wear or damage.

Replace if necessary.

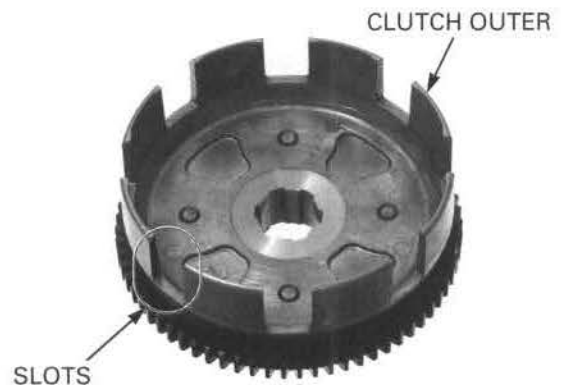

**Clutch center**

Check the grooves of the clutch center for damage or wear caused by the clutch plates.

Replace if necessary.

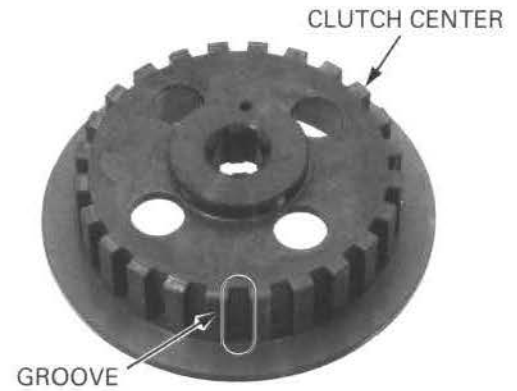

**INSTALLATION**

Install the clutch outer and spline washer.

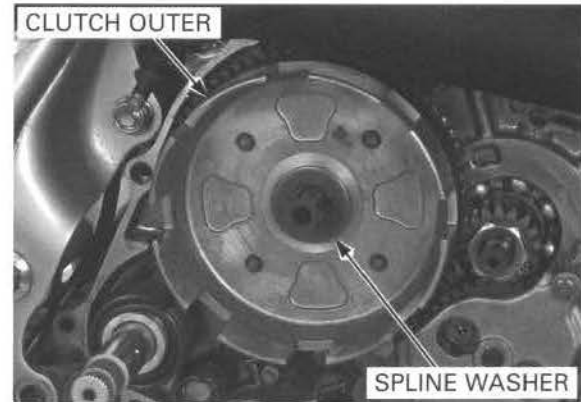

Coat the clutch discs with clean engine oil.

*CRF100F:* Assemble the pressure plate, four clutch discs, three clutch plates and clutch center, then install them in the clutch outer.

*CRF80F:* Assemble the pressure plate, three clutch discs, two clutch plates and clutch center, then install them in the clutch outer.

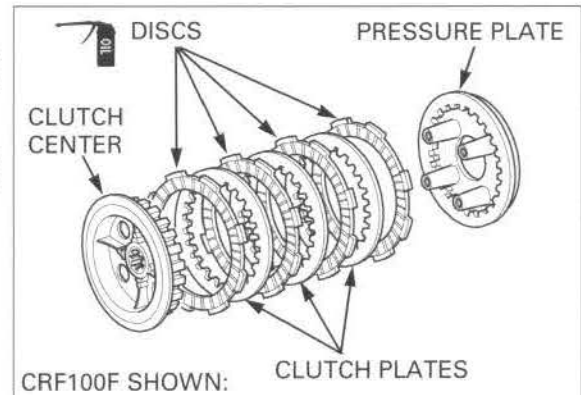

Install the snap ring.

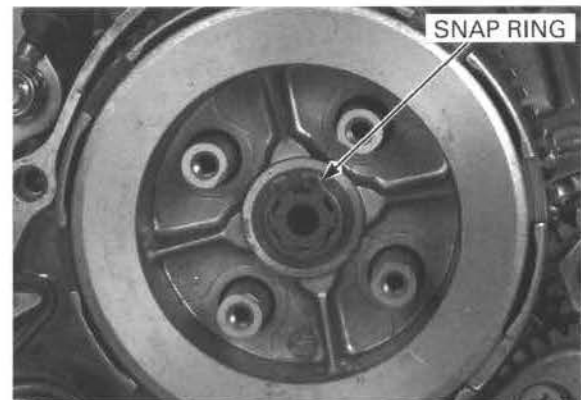

## CLUTCH/GEARSHIFT LINKAGE

Install the clutch springs and lifter plate.

*Tighten the lifter plate bolts in a crisscross pattern in 2 or 3 steps.*

Install and tighten the clutch spring bolts.

Install the lifter plate bearing and clutch lifter pin.

Install the right crankcase cover (page 9-14).

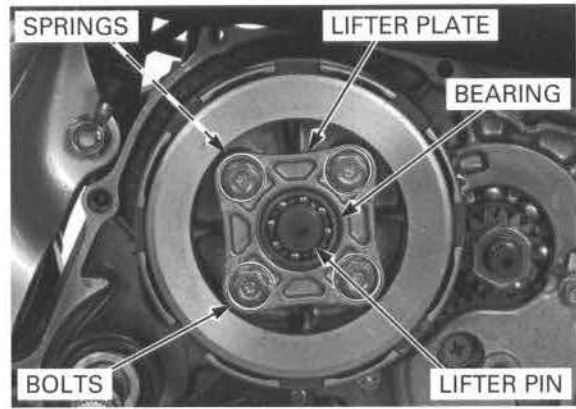

## PRIMARY DRIVE GEAR

### REMOVAL

Remove the following:

- Right crankcase cover (page 9-5)
- Oil pump (page 4-5)

Remove the oil through and spring from the crankshaft.

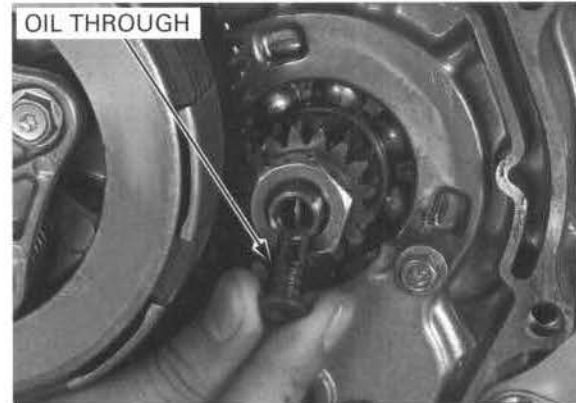

Attach the gear holder between the primary drive and driven gear as shown.

### TOOLS:

**Gear holder, M1.5**

**07724-0010200 or  
07724-001A200  
(U.S.A. only)**

Remove the lock nut.

Remove the clutch assembly (page 9-7).

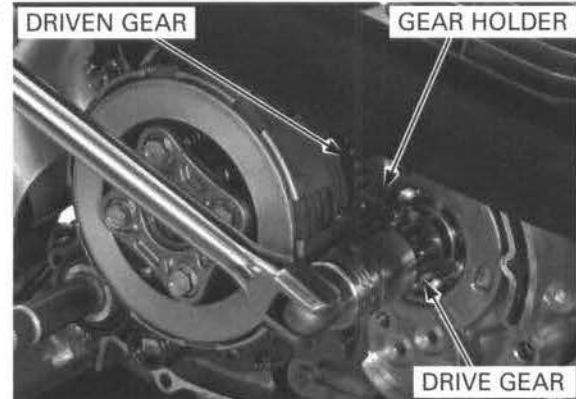

Remove the following:

- Oil through drive pin
- Washer
- Primary drive gear

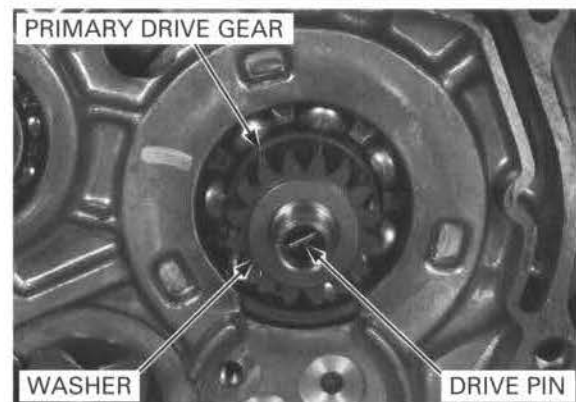



Remove the collar.

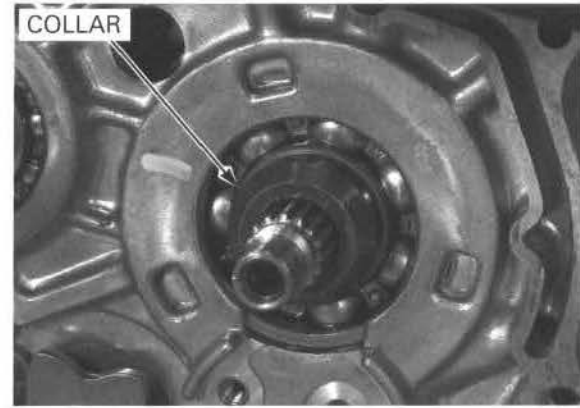

**INSTALLATION**

Install the collar.



Install the following:

- Primary drive gear
- Washer
- Oil through drive pin

Install the clutch assembly (page 9-9).

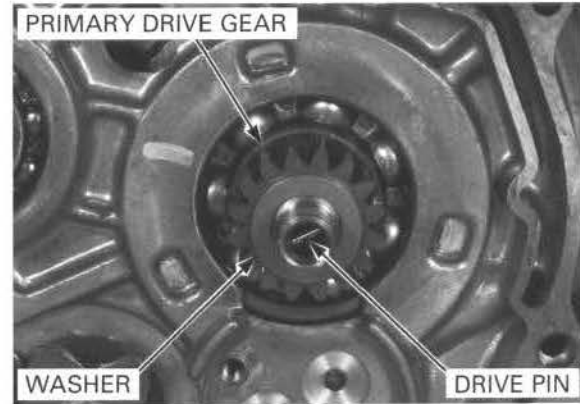

Attach the gear holder between the primary drive and driven gear as shown.

**TOOL:**

**Gear holder, M1.5**

**07724-0010200 or  
07724-001A200  
(U.S.A. only)**

*Apply oil to the  
threads and seat-  
ing surface.*

Install and tighten the lock nut to the specified torque.

**TORQUE: 39 N-m (4.0 kgf-m, 29 lbf-ft)**

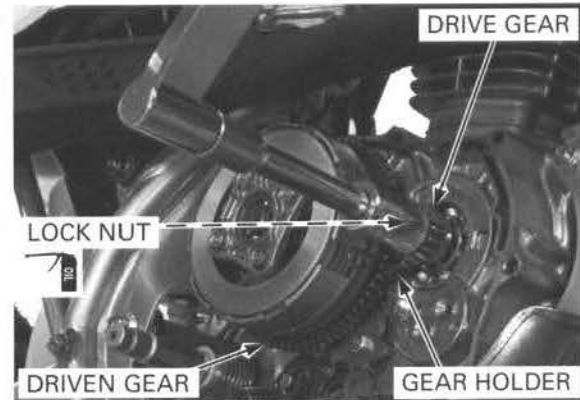

## CLUTCH/GEARSHIFT LINKAGE

Install the oil through and spring.

Install the following.

- Oil pump (page 4-5)
- Right crankcase cover(page 9-14)

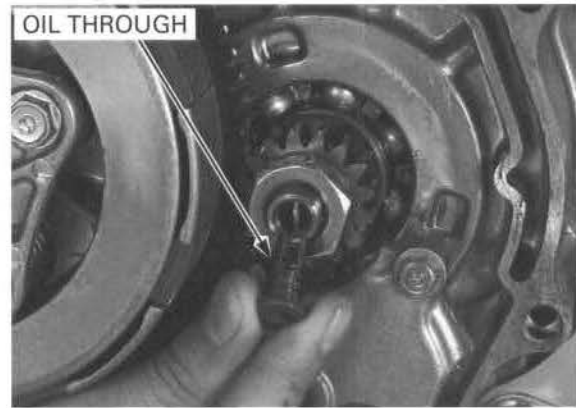

## GEARSHIFT LINKAGE

### REMOVAL

Remove the nut, bolt and gearshift pedal.

Remove the following:

- Right crankcase cover (page 9-5)
- Oil pump (page 4-5)
- Clutch assembly (page 9-7)

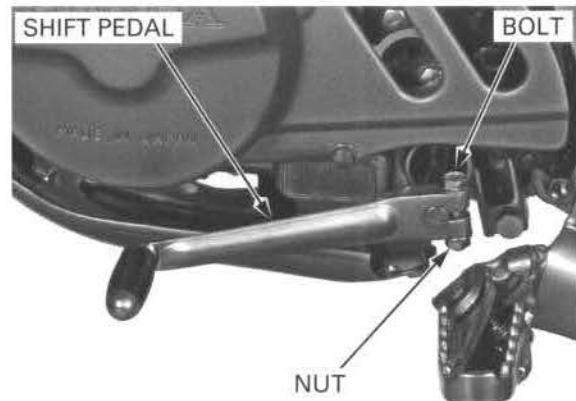

Remove the following:

- Stopper plate bolt
- Stopper arm pivot bolt
- Stopper arm
- Return spring

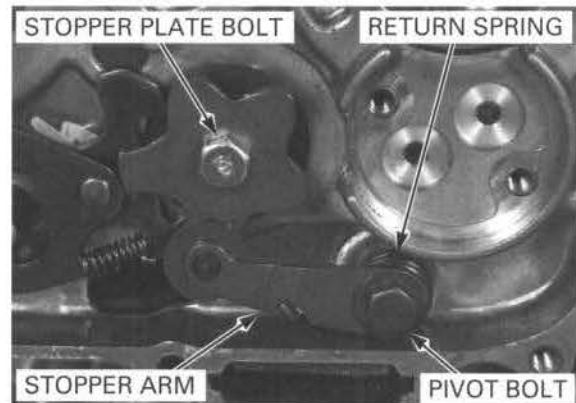

Remove the shift drum stopper plate and dowel pins.

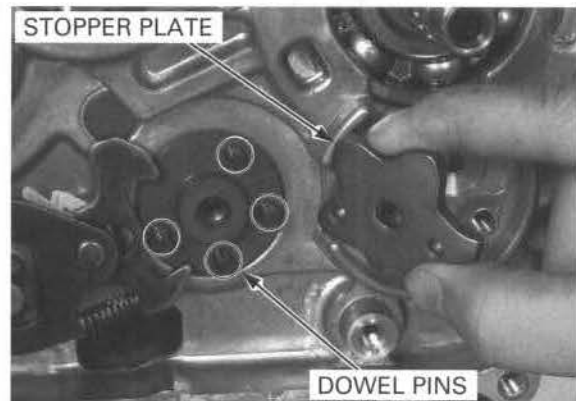

Pull the gearshift spindle out of the crankcase.

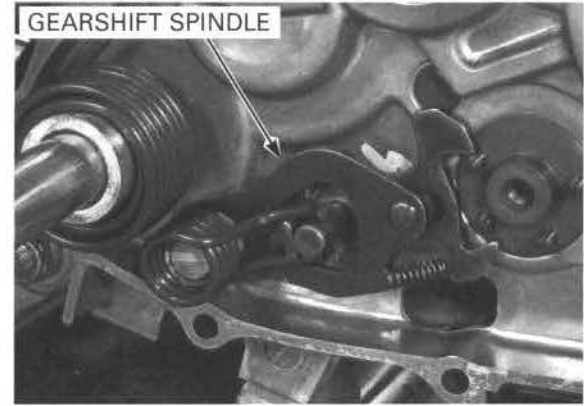

## INSPECTION

Check the gearshift spindle for wear, damage or bends and replace if necessary.

Check the return spring for fatigue or damage and replace if necessary.

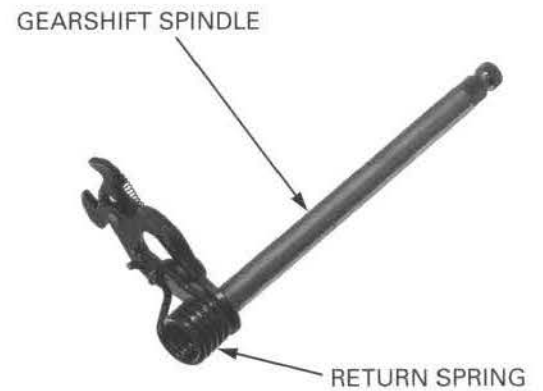

## INSTALLATION

Install the gearshift spindle into the crankcase, so that the shift return spring pin is positioned between the spring ends.

If you remove the shift return spring pin, tighten it to the specified torque.

**TORQUE: 30 N·m (3.0 kgf·m, 22 lbf·ft)**

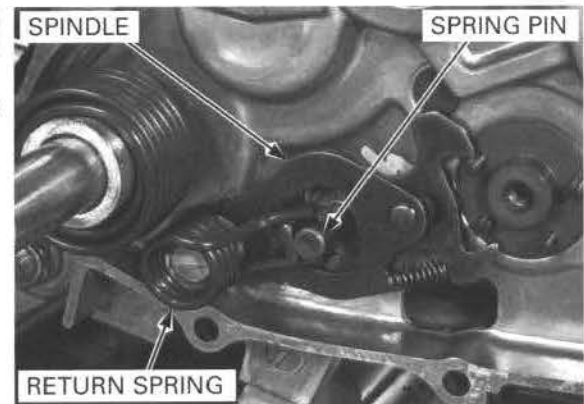

Install the dowel pins into the shift drum holes.

Install the shift drum stopper plate aligning the stopper plate holes with the dowel pins as shown.

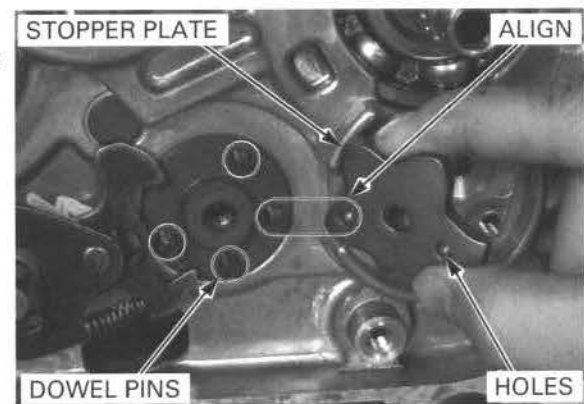

## CLUTCH/GEARSHIFT LINKAGE

Install and tighten the shift drum stopper plate bolt.

Install the stopper arm, return spring and tighten the stopper arm pivot bolt to the specified torque.

**TORQUE: 13 N·m (1.3 kgf·m, 9 lbf·ft)**

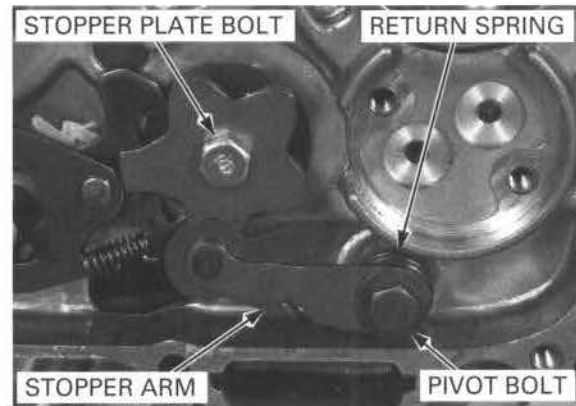

Install the gearshift pedal, bolt and tighten the nut.

Install the following:

- Oil pump (page 4-9)
- Clutch (page 9-9)
- Right crankcase cover

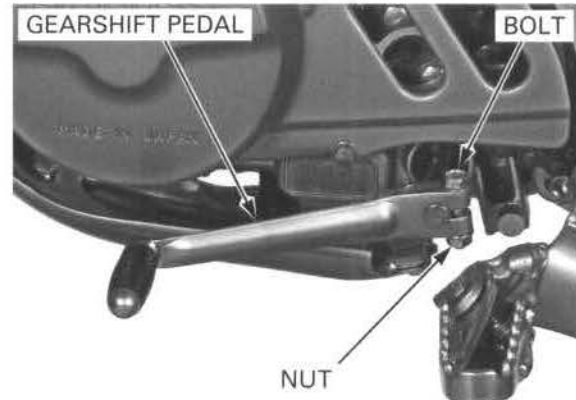

## RIGHT CRANKCASE COVER INSTALLATION

### ASSEMBLY

Install the new O-ring onto the clutch lever.



Install the following:

- Clutch lever
- Clutch lever spring
- Clutch lifter cam

Install the new cotter pin into the clutch lever.

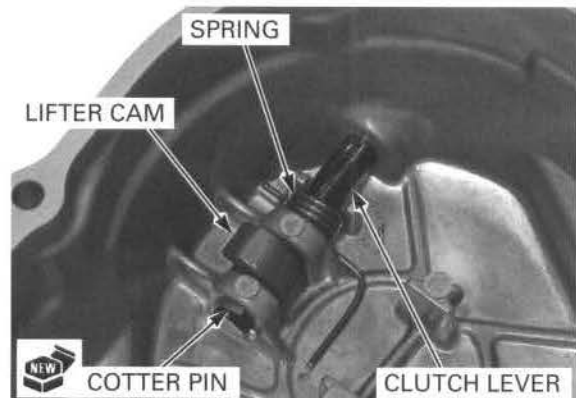

Install the new O-ring onto the clutch adjusting screw.

Install the clutch adjusting lever to the right crankcase cover.

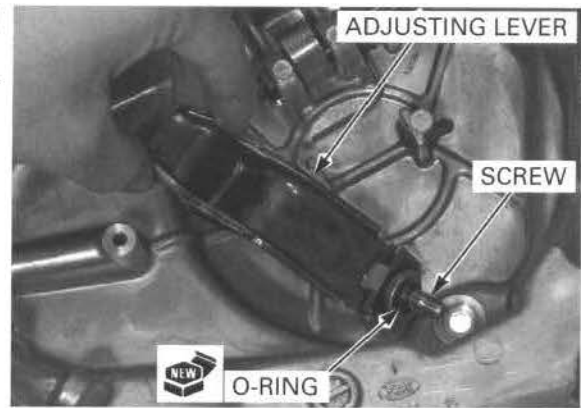

Install the clutch adjusting screw lock nut.

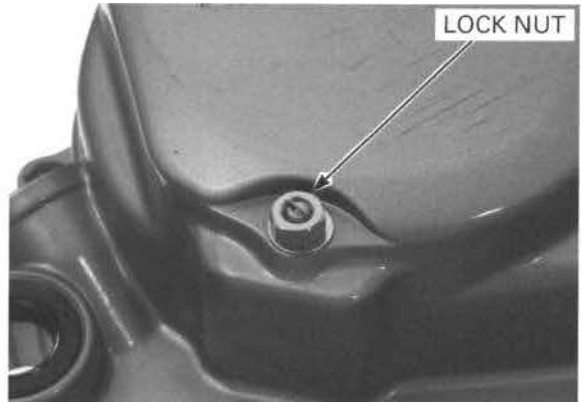

### INSTALLATION

*Be careful not to damage the gasket mating surface.*

Clean off any gasket material from the right crankcase cover mating surface.

Install the dowel pins and new gasket.

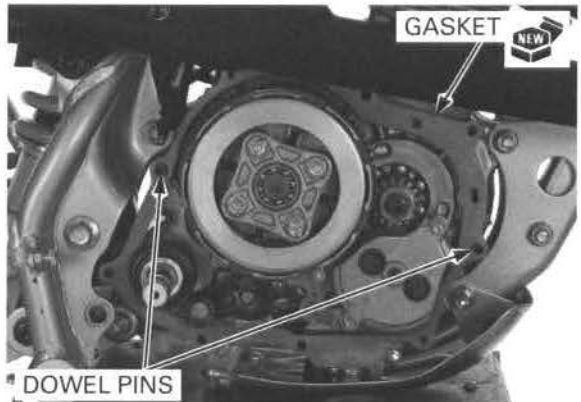

Install the right crankcase cover.

Tighten the right crankcase cover nine bolts in a crisscross pattern in 2 or 3 steps.

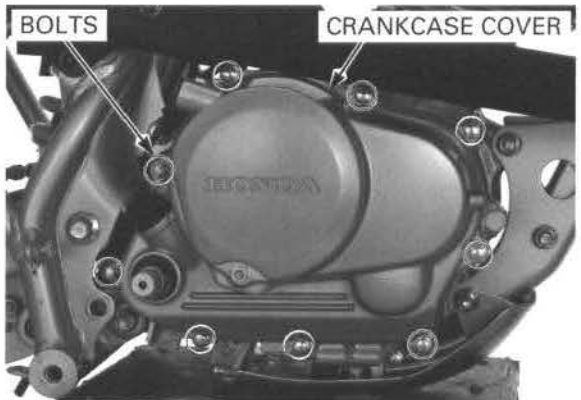

## CLUTCH/GEARSHIFT LINKAGE

Install the right foot peg and tighten the foot peg mounting bolts to the specified torque.

**TORQUE: 55 N·m (5.6 kgf·m, 41 lbf·ft)**

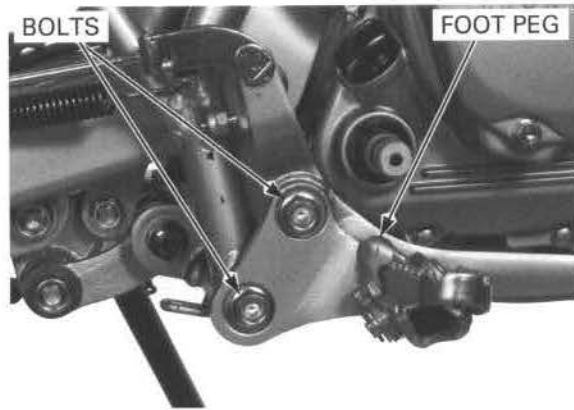

Connect the clutch cable.

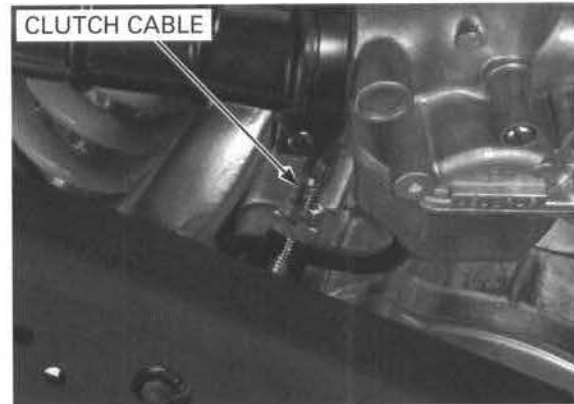

Install the kickstarter pedal and tighten the bolt to the specified torque.

**TORQUE: 12 N·m (1.2 kgf·m, 9 lbf·ft)**

Pour the recommended engine oil (page 3-13) and make sure there are no oil leaks.

Adjust the clutch (page 3-22).



# 10. ALTERNATOR

---

COMPONENT LOCATION .....	10-2	STATOR .....	10-5
SERVICE INFORMATION .....	10-3	STATOR BASE.....	10-7
LEFT CRANKCASE COVER REMOVAL ...	10-4	LEFT CRANKCASE COVER INSTALLATION .....	10-8
FLYWHEEL .....	10-4		

# ALTERNATOR

## COMPONENT LOCATION

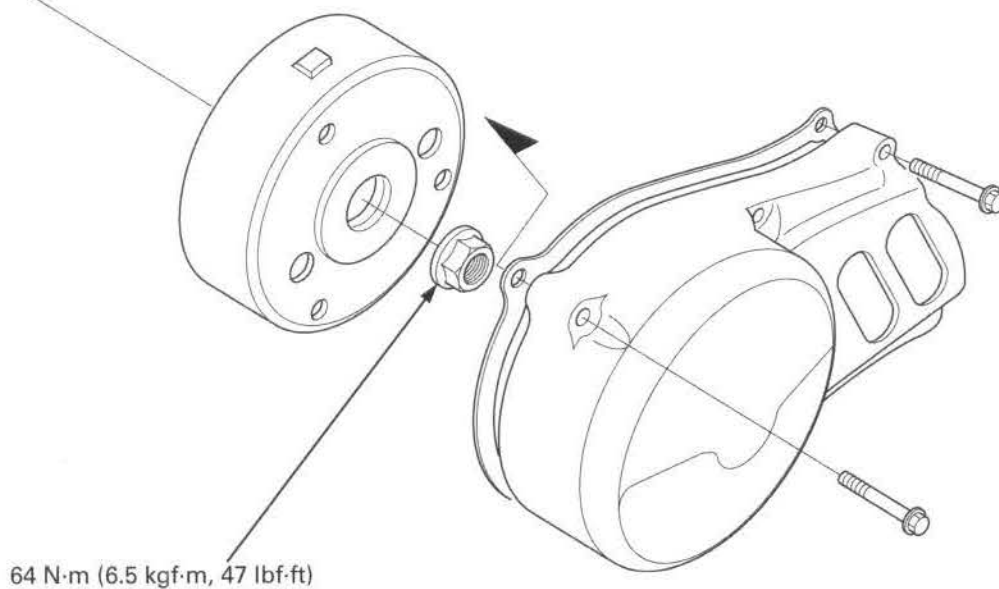
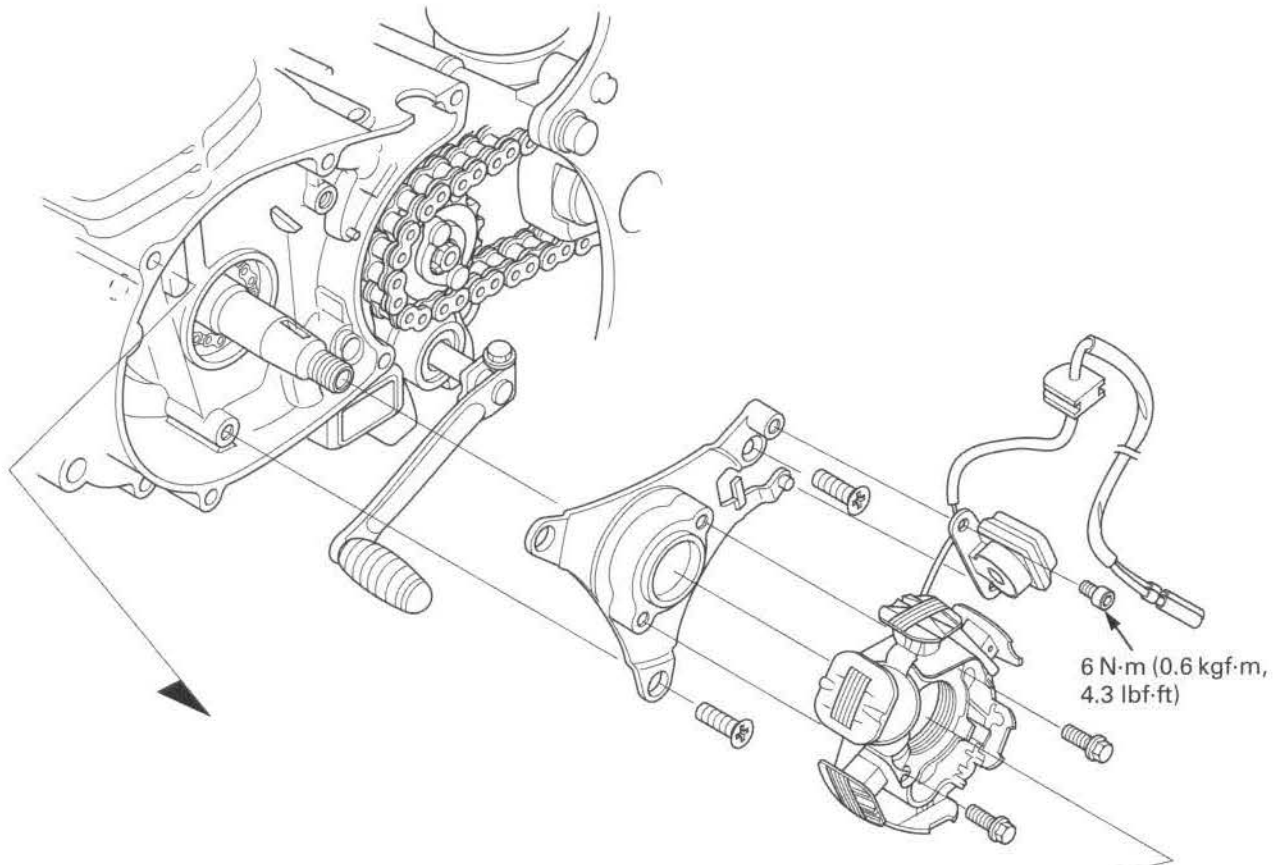



## SERVICE INFORMATION

### GENERAL

- This section covers the removal and installation of the flywheel, alternator and ignition pulse generator. These services can be done with the engine installed in the frame.
- For alternator inspection and troubleshooting, refer to section 14.

### TORQUE VALUES

Flywheel nut	64 N·m (6.5 kgf·m, 47 lbf·ft)	Apply oil to the threads and seating surface.
Pulse generator mounting bolt	6 N·m (0.6 kgf·m, 4.3 lbf·ft)	Apply a locking agent to the threads.

### TOOLS

Universal holder  
07725-0030000

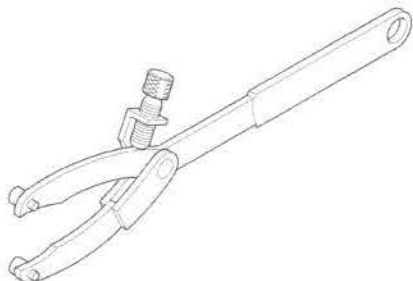

Flywheel puller  
07733-0010000

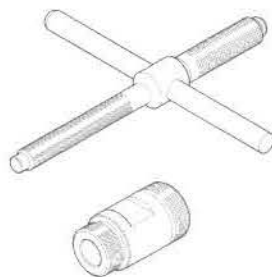

or 07933-0010000

## ALTERNATOR

### LEFT CRANKCASE COVER REMOVAL

*Loosen the left crankcase cover bolts in a criss-cross pattern in several steps.*

Remove the five SH bolts and left crankcase cover.



Remove the gasket.

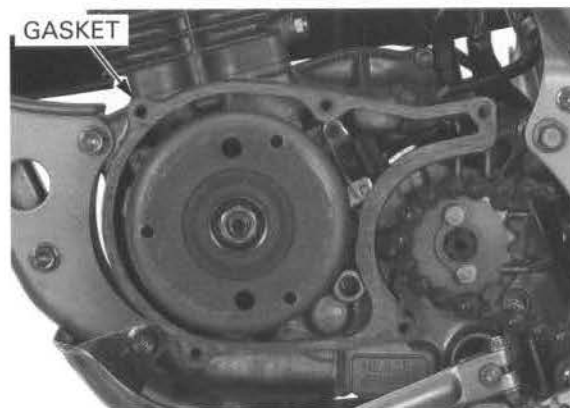

### FLYWHEEL

#### REMOVAL

Remove the left crankcase cover.

Hold the flywheel with the universal holder, then remove the flywheel nut and washer.

#### TOOL:

Universal holder                      07725-0030000

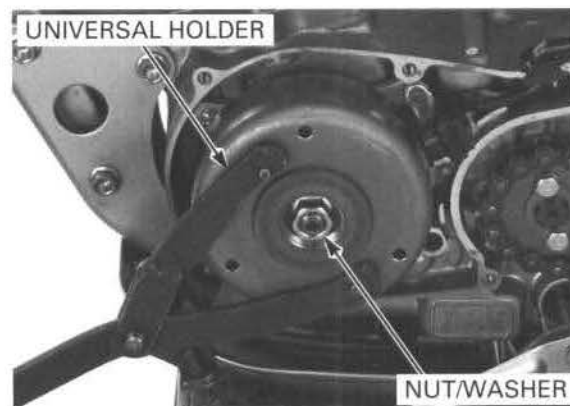

Remove the flywheel using the flywheel puller.

#### TOOLS:

Flywheel puller                      07733-0010000or  
07933-0010000

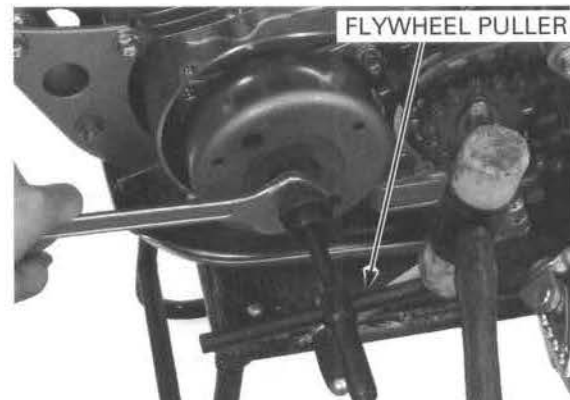

**INSTALLATION**

Clean any oil from the crankshaft and flywheel tapered areas.

Install the flywheel by aligning the woodruff key on the crankshaft with the flywheel keyway.

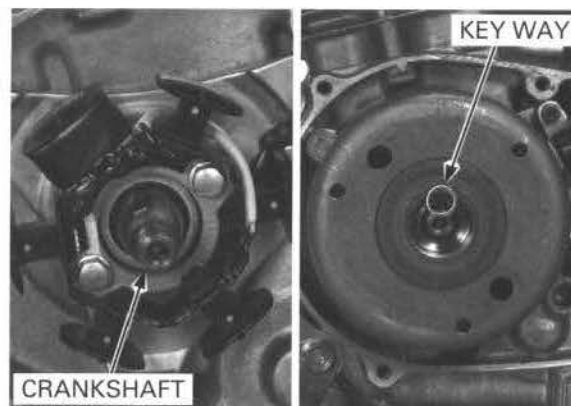

Apply engine oil to the flywheel nut threads and seating surface.

Hold the flywheel with the universal holder and install the washer and flywheel nut.

**TOOL:**

**Universal holder** 07725-0030000

Tighten the flywheel nut to the specified torque.

**TORQUE: 64 N·m (6.5 kgf·m, 47 lbf·ft)**

Install the left crankcase cover (page 10-8).

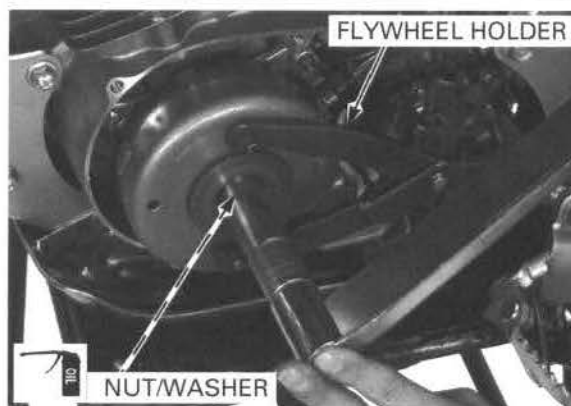
**STATOR****REMOVAL**

Remove the fuel tank (page 2-4).

Remove the tank setting rubber.

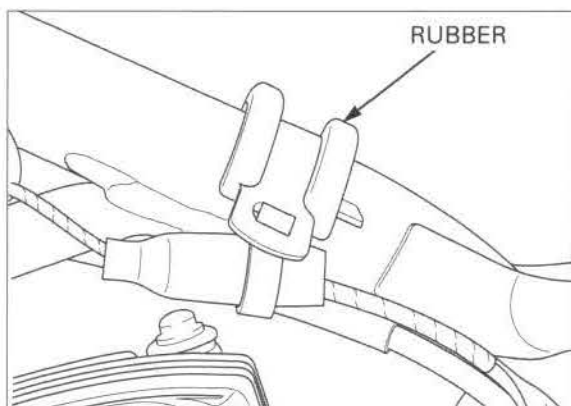

Disconnect the ignition pulse generator connector and alternator connector.

Remove the flywheel (page 10-4).



## ALTERNATOR

Remove the two stator mounting bolts.

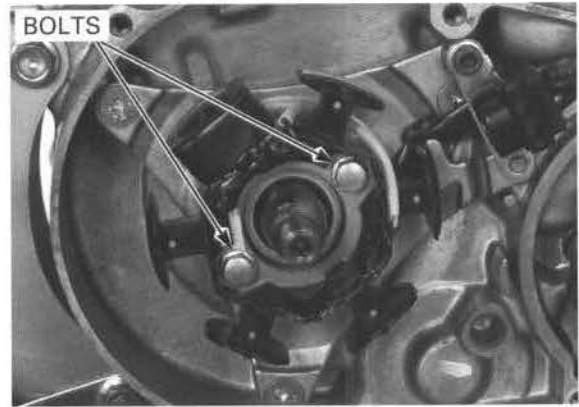

Release the wire grommet from the crankcase groove.

*CRF100F:* Remove the pulse generator mounting bolt, stator and pulse generator.

*CRF80F:* Remove the two pulse generator mounting bolts, stator and pulse generator.

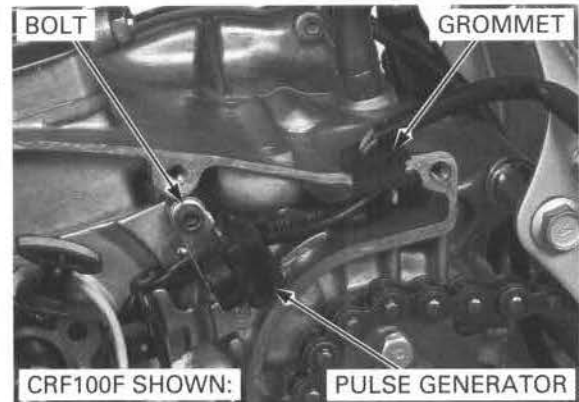

### INSTALLATION

Apply a locking agent to the pulse generator mounting bolt threads.

*CRF100F:* Install the pulse generator and tighten the bolt to the specified torque, then set the wire grommet into the crankcase groove.

*CRF80F:* Install the pulse generator and tighten the two bolts to the specified torque, then set the wire grommet into the crankcase groove.

**TORQUE: 6 N·m (0.6 kgf·m, 4.3 lbf·ft)**

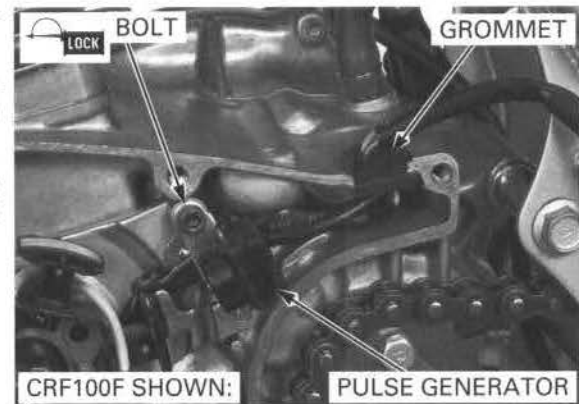

Install the stator and tighten the stator mounting bolts.

Install the flywheel (page 10-5).

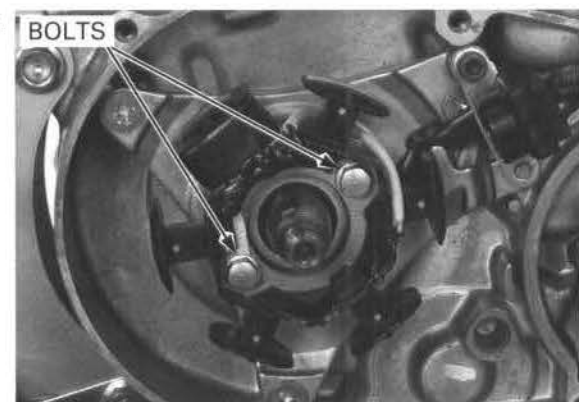

Connect the alternator and ignition pulse generator connector.

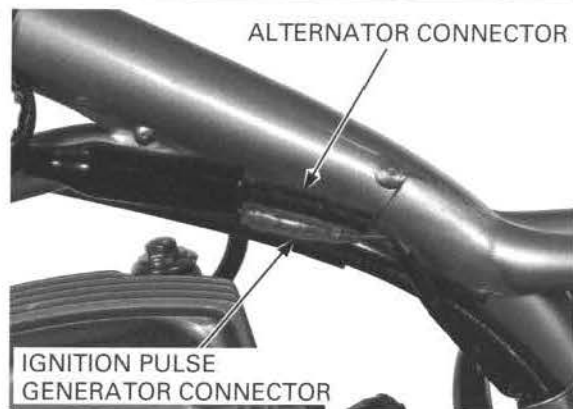

Install the tank setting rubber against the rubber stopper.

Install the fuel tank (page 2-4).

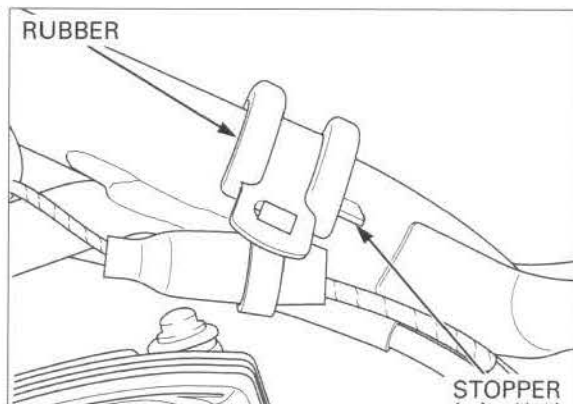

## STATOR BASE

### REMOVAL

Remove the flywheel (page 10-4).

Remove the stator (page 10-5).

Remove the woodruff key from the crankshaft.

*CRF100F:* Remove the three screws and stator base.

*CRF80F:* Remove the two screws and stator base.

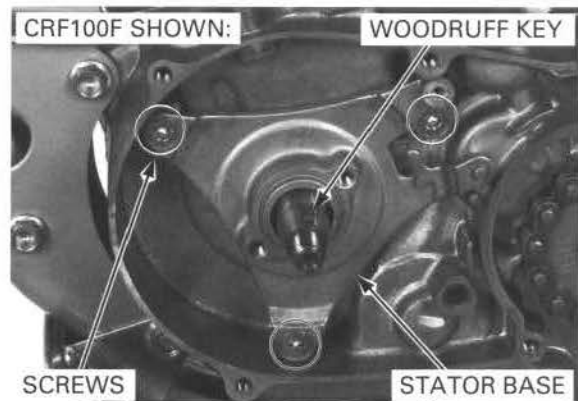

### OIL SEAL REPLACEMENT (CRF100F ONLY)

Remove the O-ring and oil seal from the stator base.

Apply oil to the new oil seal and O-ring, and install them.

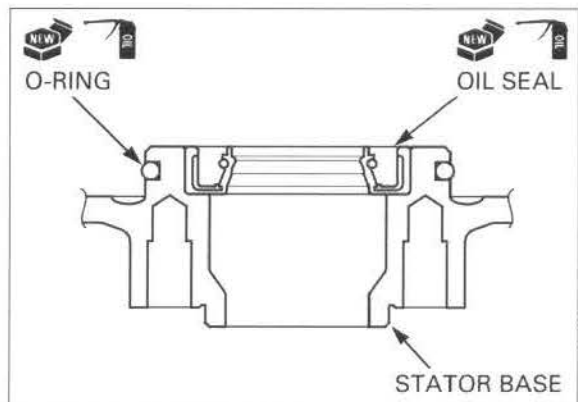

## ALTERNATOR

### INSTALLATION

*CRF100F:* Install the stator base and tighten the three screws.

*CRF80F:* Install the stator base and tighten the two screws.  
Install the woodruff key.

Install the stator (page 10-6).

Install the flywheel (page 10-5).

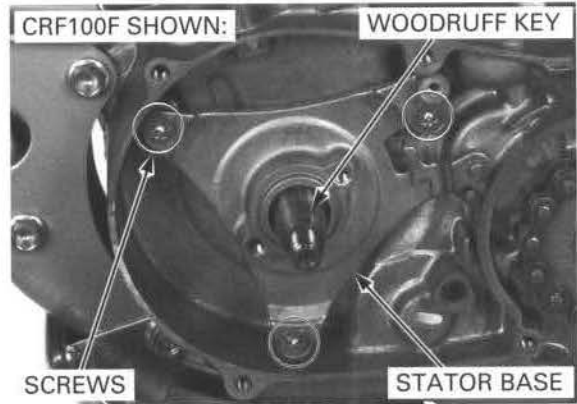

### LEFT CRANKCASE COVER INSTALLATION

Install the new gasket to the left crankcase.



Install the left crankcase cover and tighten the five SH bolts in a crisscross pattern in several steps.

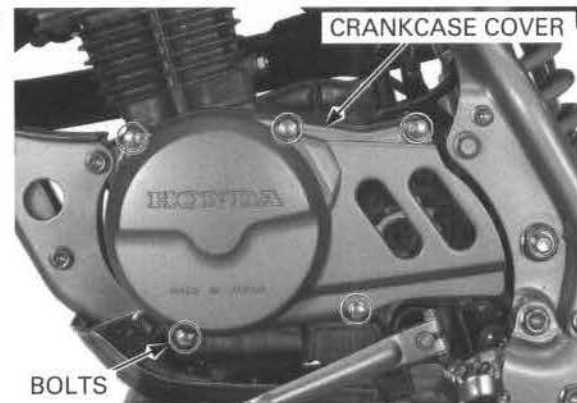

# 11. CRANKSHAFT/TRANSMISSION/KICKSTARTER

---

COMPONENT LOCATION .....	11-2	TRANSMISSION REMOVAL/ DISASSEMBLY .....	11-9
SERVICE INFORMATION .....	11-3	CRANKCASE BEARING REPLACEMENT .....	11-12
TROUBLESHOOTING .....	11-6	TRANSMISSION ASSEMBLY/ INSTALLATION .....	11-15
CRANKCASE SEPARATION .....	11-7	KICKSTARTER .....	11-18
CRANKSHAFT .....	11-8	CRANKCASE ASSEMBLY .....	11-19

COMPONENT LOCATION

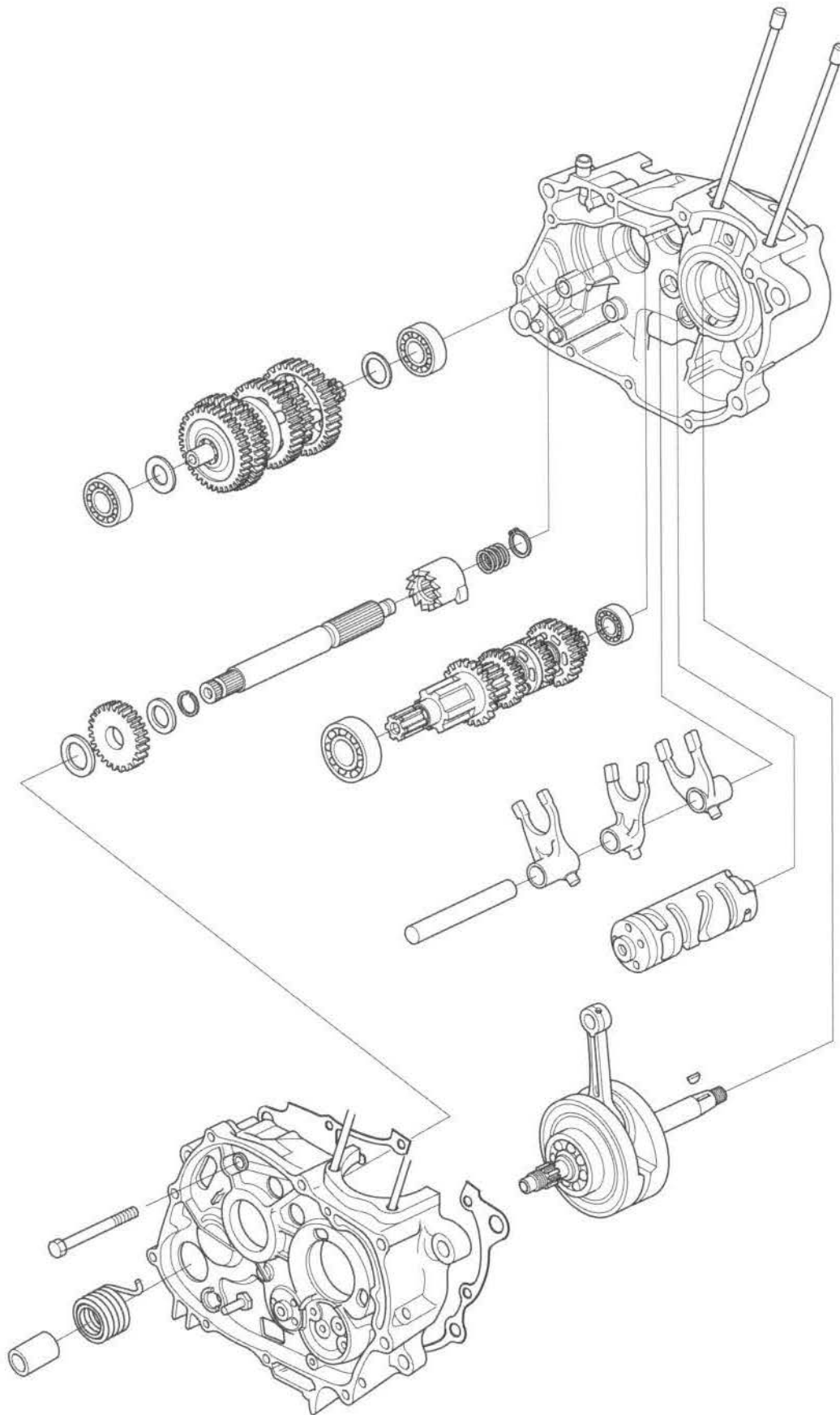



## SERVICE INFORMATION

### GENERAL

- The crankcase must be separated to service the crankshaft, transmission and kickstarter.
- The following parts must be removed before separating the crankcase.
  - Alternator (page 10-4)
  - Clutch/gearshift linkage (page 9-7)
  - Cylinder head (page 7-10)
  - Cylinder/piston (page 8-5)
  - Engine (page 6-4)
  - Oil pump (page 4-5)

### SPECIFICATIONS(CRF100F)

Unit: mm (in)

ITEM		STANDARD	SERVICE LIMIT
Crankshaft	Runout	Right	0.035 (0.0014)
		Left	0.020 (0.0008)
	Connecting rod big end radial clearance		0 – 0.008 (0 – 0.0003)
	Connecting rod big end side clearance		0.10 – 0.35 (0.0039 – 0.0138)
Transmission	Gear I.D.	M4, M5	17.016 – 17.034 (0.6699 – 0.6706)
		C1	20.662 – 20.643 (0.8135 – 0.8127)
		C2	19.520 – 19.541 (0.7685 – 0.7693)
		C3	18.016 – 18.034 (0.7093 – 0.7100)
	Bushing O.D.	C1	20.559 – 20.580 (0.8094 – 0.8102)
	Gear to bushing clearance (C1)		0.042 – 0.084 (0.0017 – 0.0033)
	Mainshaft O.D.	M4,M5	16.966 – 16.984 (0.6680 – 0.6687)
	Countershaft O.D.	C2	19.459 – 19.480 (0.7661 – 0.7669)
		C3	17.966 – 17.984 (0.7073 – 0.7080)
		Gear to shaft clearance	M4
C2	0.040 – 0.082 (0.0016 – 0.0032)		
C3	0.032 – 0.068 (0.0013 – 0.0027)		
Shift fork, shift fork shaft	Shift fork shaft O.D.		11.976 – 11.994 (0.4715 – 0.4722)
	Shift fork I.D.		12.000 – 12.018 (0.4724 – 0.4731)
	Shift fork claw thickness		4.93 – 5.00 (0.194 – 0.197)
Kickstarter	Spindle O.D.		17.959 – 17.980 (0.7070 – 0.7079)
	Pinion I.D.		18.020 – 18.041 (0.7094 – 0.7103)





# CRANKSHAFT/TRANSMISSION/KICKSTARTER

## SPECIFICATIONS(CRF80F)

Unit: mm (in)

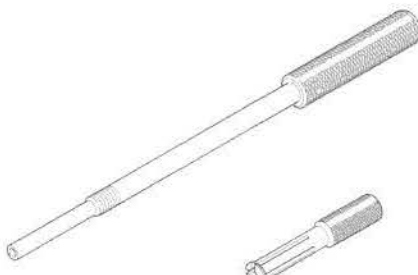
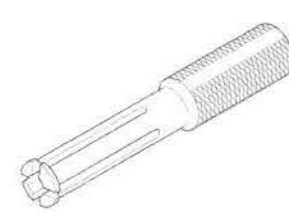
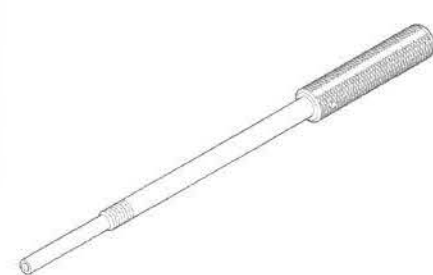
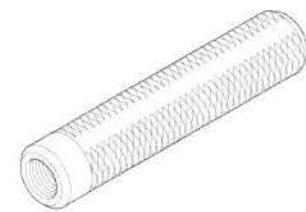
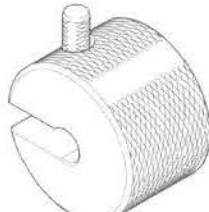
ITEM			STANDARD	SERVICE LIMIT
Crankshaft	Runout	Right	0.035 (0.0014)	0.085 (0.0033)
		Left	0.020 (0.0008)	0.070 (0.0028)
	Connecting rod big end radial clearance		0 – 0.008 (0 – 0.0003)	0.010 (0.0004)
	Connecting rod big end side clearance		0.10 – 0.35 (0.0039 – 0.0138)	0.60 (0.024)
Transmission	Gear I.D.	M4, M5	17.016 – 17.034 (0.6699 – 0.6706)	17.05 (0.671)
		C1	17.022 – 17.043 (0.6702 – 0.6710)	17.06 (0.672)
		C2	19.520 – 19.541 (0.7685 – 0.7693)	19.56 (0.770)
		C3	17.016 – 17.034 (0.6699 – 0.6706)	17.05 (0.671)
	Bushing O.D.	C1	20.559 – 20.580 (0.8094 – 0.8102)	20.54 (0.809)
	Gear to bushing clearance (C1)		0.042 – 0.084 (0.0017 – 0.0033)	0.12 (0.005)
	Mainshaft O.D.	M4,M5	16.966 – 16.984 (0.6680 – 0.6687)	16.95 (0.667)
	Countershaft O.D.	C2	19.459 – 19.480 (0.7661 – 0.7669)	19.44 (0.765)
		C3	16.966 – 16.984 (0.6680 – 0.6687)	16.95 (0.667)
	Gear to shaft clearance	M4	0.032 – 0.068 (0.0013 – 0.0027)	0.10 (0.004)
		C2	0.040 – 0.082 (0.0016 – 0.0032)	0.12 (0.005)
C3		0.032 – 0.068 (0.0013 – 0.0027)	0.10 (0.004)	
Shift fork, shift fork shaft	Shift fork shaft O.D.		11.976 – 11.994 (0.4715 – 0.4722)	11.96 (0.471)
	Shift fork I.D.		12.000 – 12.018 (0.4724 – 0.4731)	12.05 (0.474)
	Shift fork claw thickness		4.93 – 5.00 (0.194 – 0.197)	4.70 (0.19)
Kickstarter	Spindle O.D.		17.959 – 17.980 (0.7070 – 0.7079)	17.88 (0.704)
	Pinion I.D.		18.020 – 18.041 (0.7094 – 0.7103)	18.06 (0.711)

TOOLS

<p>Bearing remover set, 12 mm 07936-1660101</p>  <p>07936-166010A (U.S.A. only)</p>	<p>Bearing remover head, 12 mm 07936-1660110</p>  <p>Not available in U.S.A.</p>	<p>Bearing remover shaft 07936-1660120</p>  <p>Not available in U.S.A.</p>
<p>Bearing remover shaft handle 07936-3710100</p> 	<p>Bearing remover weight 07741-0010201</p>  <p>or 07936-371020A or 07936-3710200 (U.S.A. only)</p>	<p>Driver 07749-0010000</p> 
<p>Pilot, 12 mm 07746-0040200</p> 	<p>Pilot, 17 mm 07746-0040400</p> 	<p>Pilot, 25 mm 07746-0040600</p> 
<p>Attachment, 32 x 35 mm 07746-0010100</p> 	<p>Attachment, 37 x 40 mm 07746-0010200</p> 	<p>Attachment, 42 x 47 mm 07746-0010300</p> 

**TROUBLESHOOTING**

**Crankshaft noisy**

- Worn connecting rod big end bearing
- Bent connecting rod
- Worn crankshaft main journal bearing

**Transmission jumps out of gear**

- Worn gear dogs or slots
- Bent fork shaft
- Worn or bent shift forks
- Broken shift drum stopper
- Broken shift linkage return spring

**Hard to shift**

- Improper clutch operation
- Incorrect clutch adjustment
- Incorrect engine oil viscosity
- Bent shift fork
- Bent shift fork shaft
- Bent shift fork claw
- Damaged shift drum cam grooves
- Bent shift spindle

## CRANKCASE SEPARATION

Refer to page 11-3 for the parts which must be removed before separating the crankcase. Remove the kickstarter spindle return spring and spring collar.

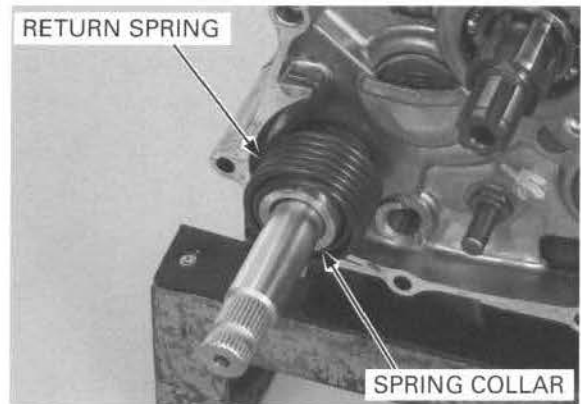

Remove the two bolts.

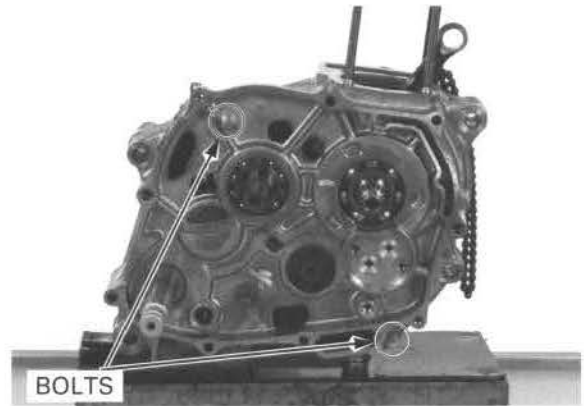

Place the left crankcase down.  
Separate the right and left crankcase halves.

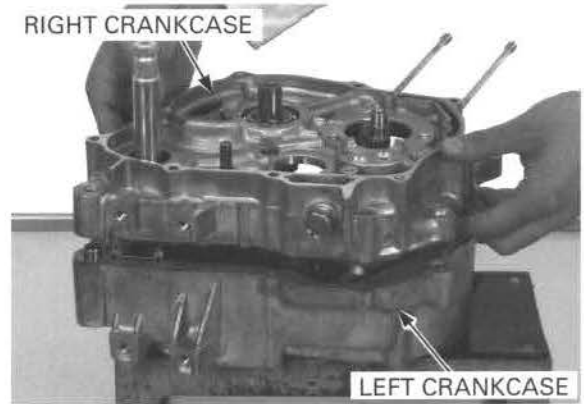

Remove the gasket and dowel pins.

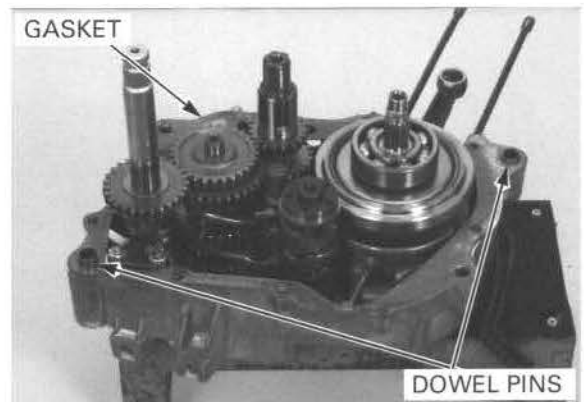

## CRANKSHAFT

### REMOVAL

Separate the crankcase halves (page 11-7).  
Remove the crankshaft from the left crankcase.

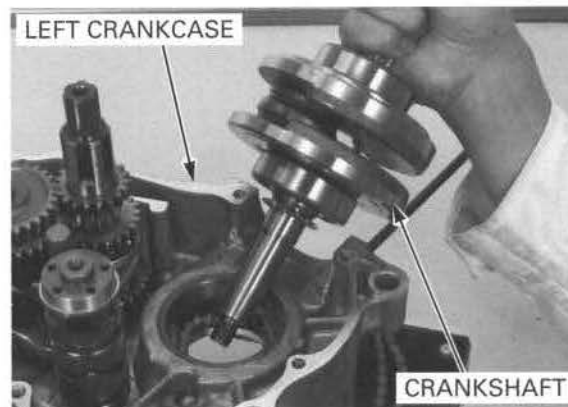

### INSPECTION

Measure the connecting rod big end side clearance with a feeler gauge.

**SERVICE LIMIT: 0.60 mm (0.024 in)**



Measure the connecting rod big end radial clearance at symmetrical points as shown.

**SERVICE LIMIT: 0.010 mm (0.0004 in)**

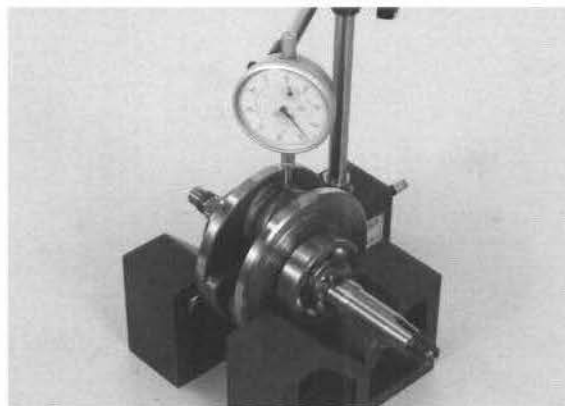

Turn the outer race of the crankshaft bearing with your finger.

The bearing should turn smoothly and quietly.

Also check that the inner race of the bearing fits tightly on the crankshaft.

Check the timing sprocket for wear or damage.

If you replacing the timing sprocket, align the center of the sprocket teeth with the center of woodruff key groove.

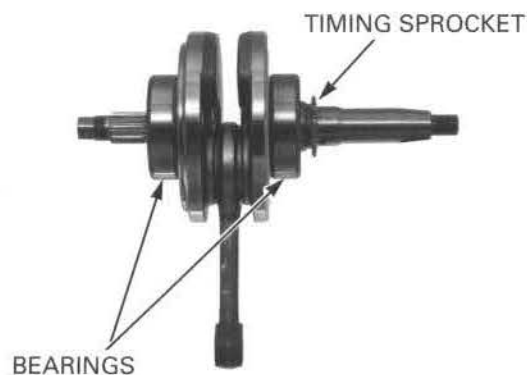

Place the crankshaft on a stand or V-blocks and measure the runout using a dial gauge.

The measuring locations are shown in the illustration.

**SERVICE LIMITS:**

**Right: 0.085 mm (0.0033 in)**

**Left: 0.070 mm (0.0028 in)**

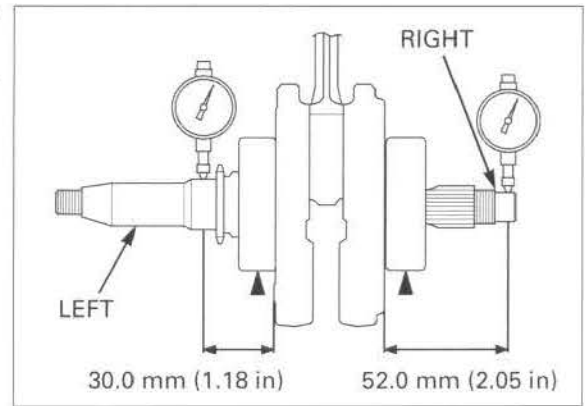

**INSTALLATION**

*Be careful not to damage the cam chain.* Install the crankshaft into the left crankcase. Assemble the crankcase (page 11-19).

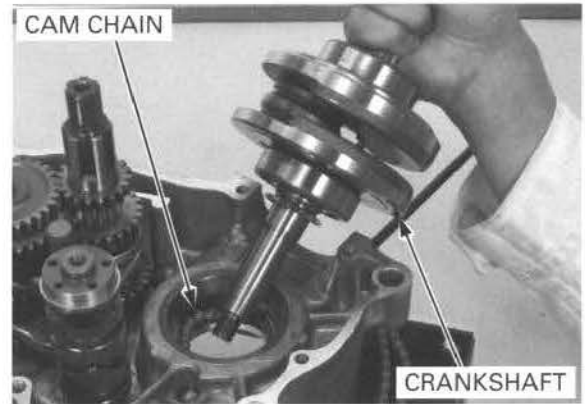

**TRANSMISSION REMOVAL/ DISASSEMBLY**

**REMOVAL**

Separate the crankcase halves (page 11-7).  
 Remove the kickstarter spindle from the left crankcase (page 11-18).  
 Remove the shift fork shaft.

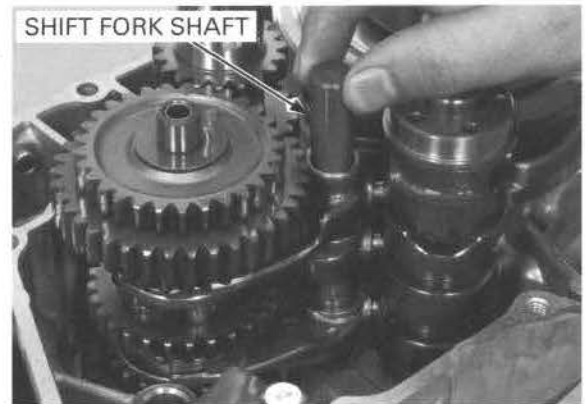

Remove the shift forks.

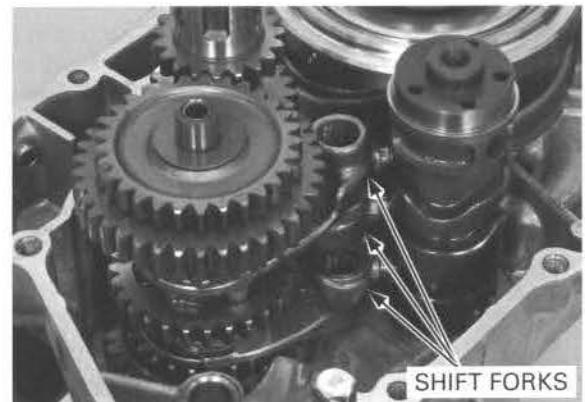

## CRANKSHAFT/TRANSMISSION/KICKSTARTER

Remove the shift drum.

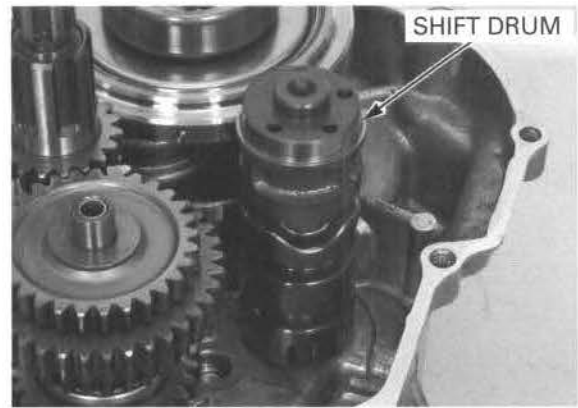

Remove the mainshaft and countershaft as an assembly.

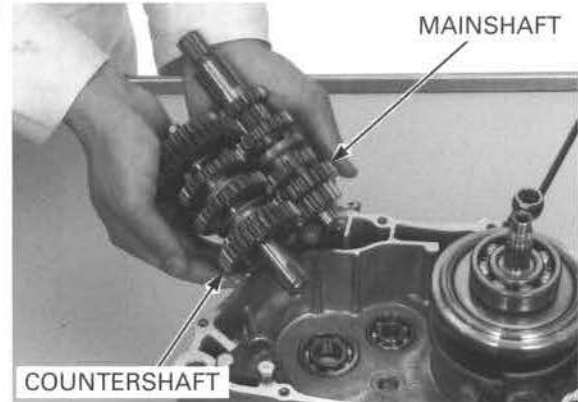

### DISASSEMBLY

- Keep track of the disassembled parts (gears, bushings, washers, and snap rings) by stacking them on a tool or slipping them onto a piece of wire.
- Do not expand the snap ring more than necessary for removal. To remove a snap ring, expand the snap ring and pull it off using the gear behind it.

Disassemble the mainshaft and countershaft.

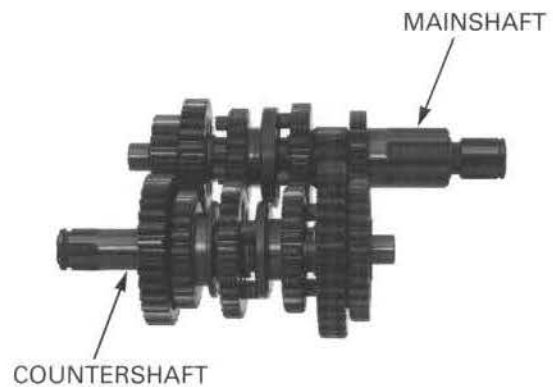

### INSPECTION

Check the gear dogs, dog holes and teeth for abnormal wear or lack of lubrication. Measure the I.D. of each gear.

#### SERVICE LIMITS:

CRF100F:	M4, M5:	17.05 mm (0.671 in)
	C1:	20.66 mm (0.813 in)
	C2:	19.56 mm (0.770 in)
CRF80F:	M4, M5:	17.05 mm (0.671 in)
	C1:	17.06 mm (0.672 in)
	C2:	19.56 mm (0.770 in)
	C3:	17.05 mm (0.671 in)





**BUSHING**

*CRF100F:* Check the bushing for damage or excessive wear.  
Measure the O.D. of C1 bushing.

**SERVICE LIMIT: 20.54 mm (0.809 in)**

Calculate the gear to bushing clearance.

**SERVICE LIMIT: 0.12 mm (0.005 in)**

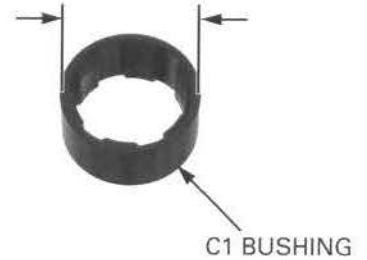

**MAINSHAFT/COUNTERSHAFT**

Check the spline grooves and sliding surfaces for damage or abnormal wear.

Measure the O.D. of the mainshaft and countershaft at the gear sliding area.

**SERVICE LIMITS:**

**Mainshaft: M4, M5 gear: 16.95 mm (0.667 in)**

**Countershaft: C2 Gear: 19.44 mm (0.765 in)**

**C3 Gear:**

**CRF100F: 17.95 mm (0.707 in)**

**CRF80F: 16.95 mm (0.667 in)**

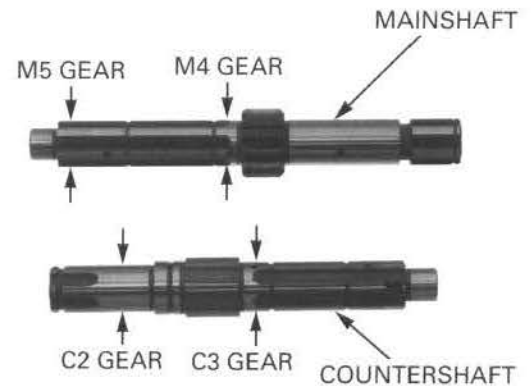

**SHIFT DRUM**

Inspect the shift drum for scoring, scratches or evidence of insufficient lubrication.

Check the shift drum grooves for abnormal wear or damage.



**SHIFT FORK**

Check the shift fork for abnormal wear or deformation.

Measure the I.D. of the shift fork.

**SERVICE LIMIT: 12.05 mm (0.474 in)**

Measure the shift fork claw thickness.

**SERVICE LIMIT: 4.70 mm (0.19 in)**



## CRANKSHAFT/TRANSMISSION/KICKSTARTER

Check the shift fork shaft for abnormal wear or deformation.

Measure the shift fork shaft O.D.

**SERVICE LIMIT: 11.96 mm (0.471 in)**

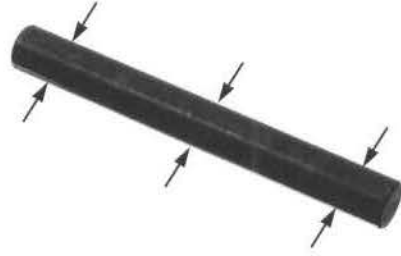

## CRANKCASE BEARING REPLACEMENT

Turn the inner race of each bearing with your finger. The bearings should turn smoothly and quietly. Also check that the bearing outer race fits tightly in the crankcase.

Remove and discard the bearing if the race does not turn smoothly, quietly or fits loosely in the crankcase.

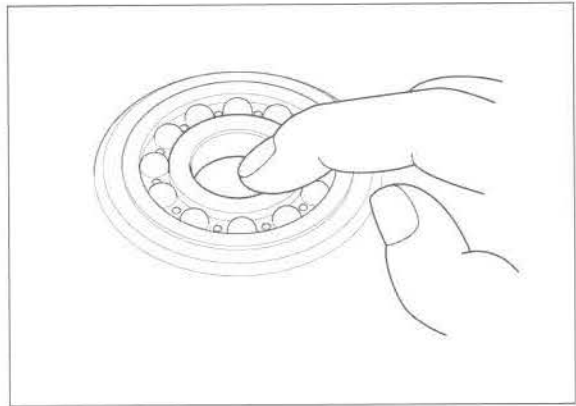

### RIGHT CRANKCASE BEARINGS

Separate the crankcase halves (page 11-7).

Drive the mainshaft bearing out of the right crankcase.

Remove the countershaft bearing using the special tools as shown.

#### TOOLS:

Bearing remover set, 12 mm	07936-1660101
Bearing remover shaft	07936-1660120
Bearing remover head, 12 mm	07936-1660110
Bearing remover weight	07741-0010201

#### TOOLS (U.S.A. only):

Bearing remover, 12 mm	07936-166010A
Bearing remover shaft handle	07936-3710100
Bearing remover weight	07936-371020A or 07936-3710200

Drive new mainshaft bearing into the right crankcase using the special tools as shown.

#### TOOLS:

Driver	07749-0010000
Attachment, 42 x 47 mm	07746-0010300
Pilot, 25 mm	07746-0040600

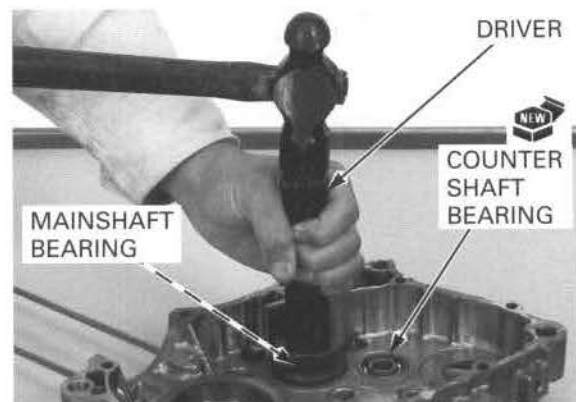

Drive new countershaft bearing into the right crankcase using the special tools as shown.

**TOOLS:**

<b>Driver</b>	<b>07749-0010000</b>
<b>Attachment, 32 x 35 mm</b>	<b>07746-0010100</b>
<b>Pilot, 12 mm</b>	<b>07746-0040200</b>

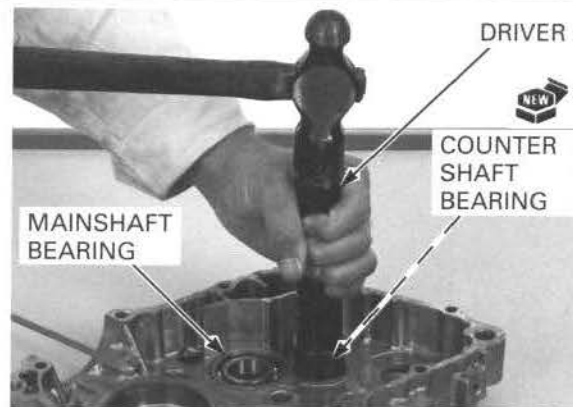

**LEFT CRANKCASE BEARINGS**

Remove the following.

- Crankshaft (page 11-8)
- Kickstarter spindle (page 11-18)
- Transmission (page 11-9)

Remove the left countershaft oil seal.

Drive the countershaft bearing out of the left crankcase.

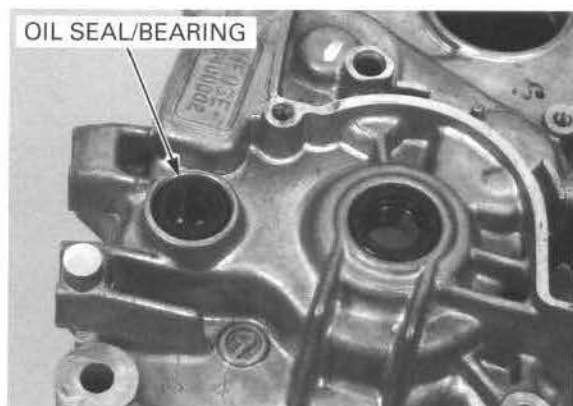

Remove the mainshaft bearing using the special tools as shown.

**TOOLS:**

<b>Bearing remover set, 12 mm</b>	<b>07936-1660101</b>
<b>Bearing remover shaft</b>	<b>07936-1660120</b>
<b>Bearing remover head, 12 mm</b>	<b>07936-1660110</b>
<b>Bearing remover weight</b>	<b>07741-0010201</b>

**TOOLS (U.S.A. only):**

<b>Bearing remover, 12 mm</b>	<b>07936-166010A</b>
<b>Bearing remover shaft handle</b>	<b>07936-3710100</b>
<b>Bearing remover weight</b>	<b>07936-371020A or 07936-3710200</b>

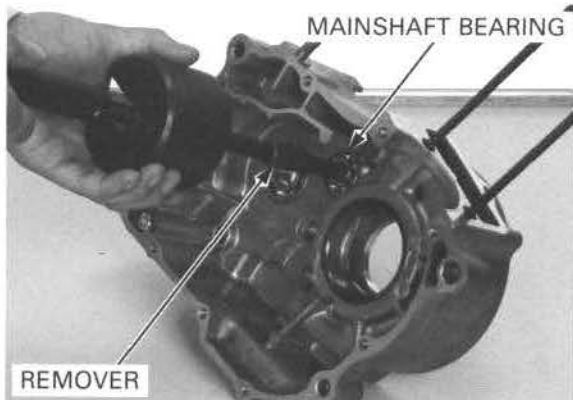

Drive new mainshaft bearing into the left crankcase using the special tools as shown.

**TOOLS:**

<b>Driver</b>	<b>07749-0010000</b>
<b>Attachment, 32 x 35 mm</b>	<b>07746-0010100</b>
<b>Pilot, 12 mm</b>	<b>07746-0040200</b>

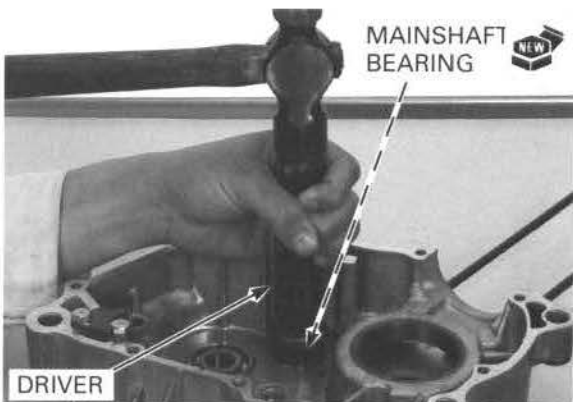

## CRANKSHAFT/TRANSMISSION/KICKSTARTER

Drive new countershaft bearing into the left crankcase using the special tools as shown.

### TOOLS:

Driver	07749-0010000
Attachment, 37 x 40 mm	07746-0010200
Pilot, 17 mm	07746-0040400

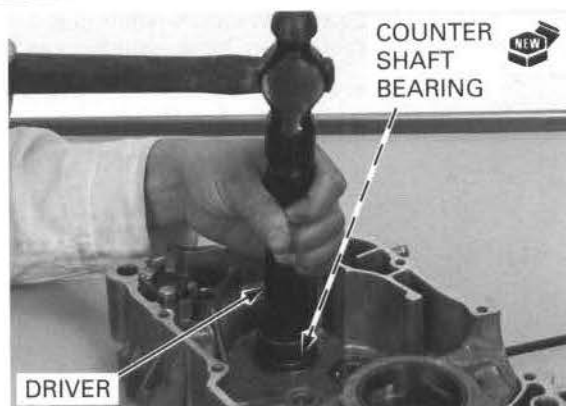

Install the new countershaft oil seal on the left crankcase.

Apply oil to the new countershaft oil seal lip.

Install the following:

- Crankshaft (page 11-9)
- Transmission (page 11-15)
- Kickstarter spindle (page 11-19)
- Assemble the crankcase (page 11-19)



# TRANSMISSION ASSEMBLY/ INSTALLATION

## TRANSMISSION ASSEMBLY

Clean all parts in solvent.

Apply molybdenum oil solution to the gear, bushing sliding surface and shift fork grooves to ensure initial lubrication.

Assemble all parts into their original positions.

### Mainshaft:

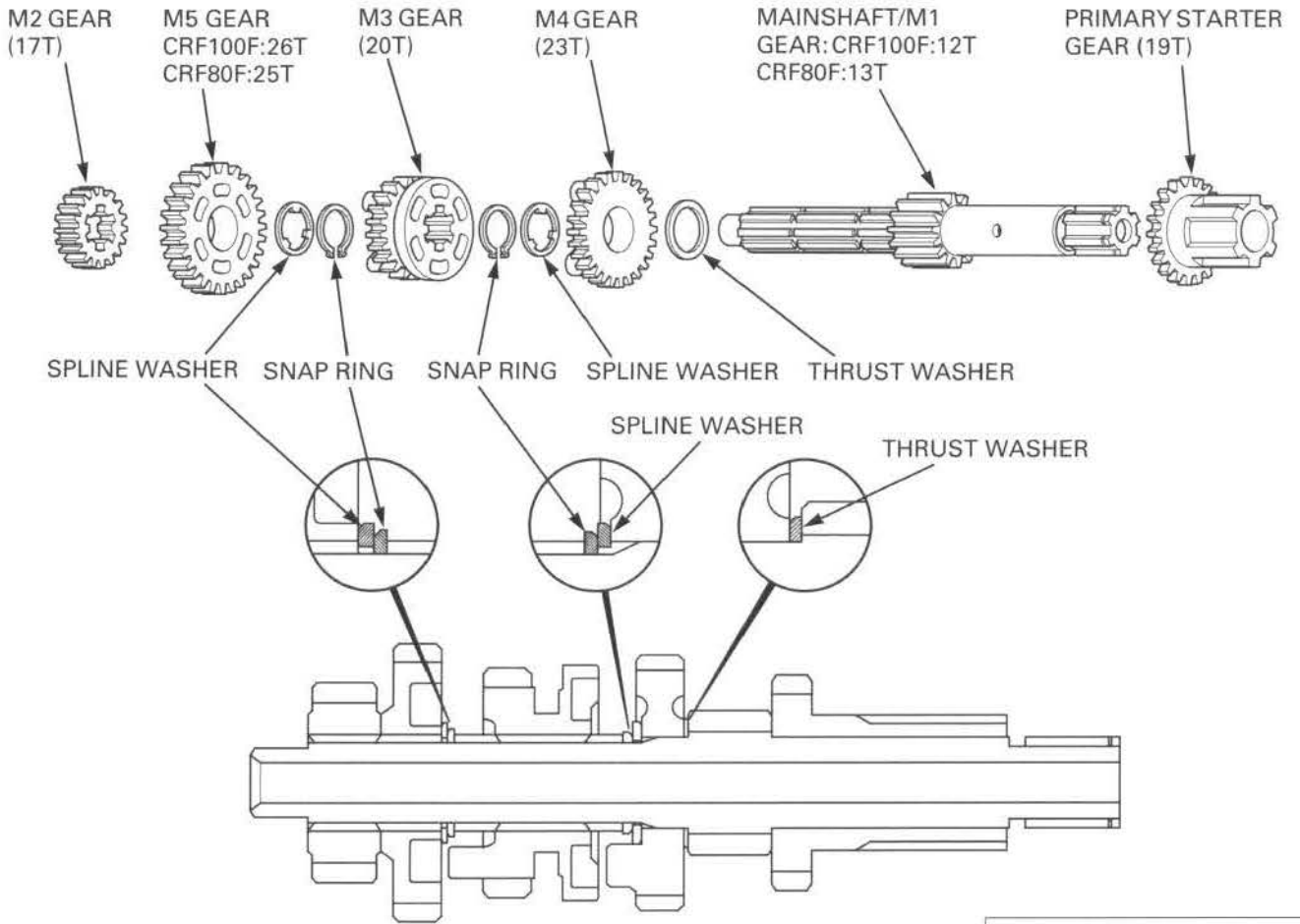

 Gear and bushing sliding surfaces and shift fork grooves

# CRANKSHAFT/TRANSMISSION/KICKSTARTER

## Countershaft:

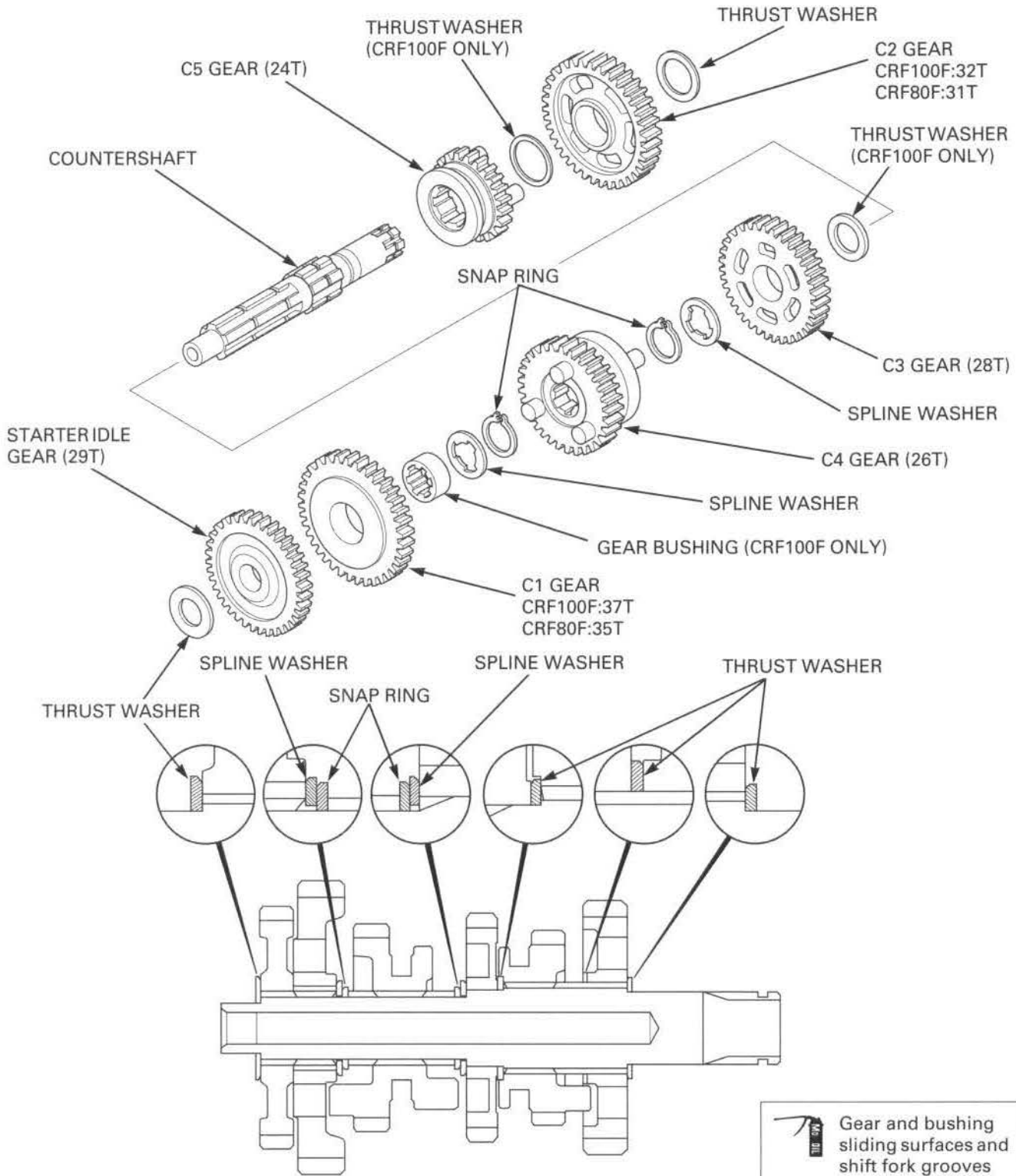

- Always install the thrust washer and snap ring with the chamfered (rolled) edge facing away from the thrust load.
- Install the snap ring so that its end gap aligns with the groove of the splines.
- Make sure that the snap ring is fully seated in the shaft groove after installing it.

**TRANSMISSION INSTALLATION**

Coat each gear with molybdenum disulfide oil and check for smooth movement.

Apply molybdenum disulfide oil to the shift fork grooves in the M3, C4 and C5 gear.

Assemble the mainshaft and countershaft as shown.

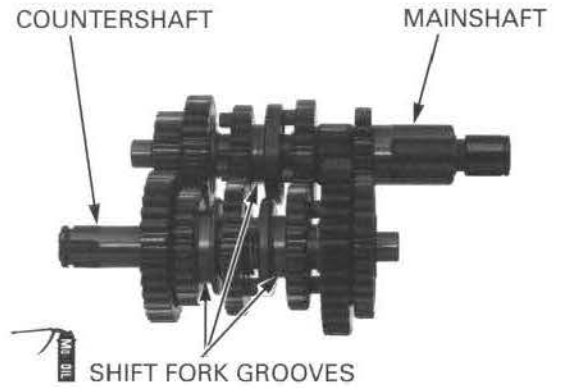

Install the mainshaft and countershaft as an assembly into the left crankcase.

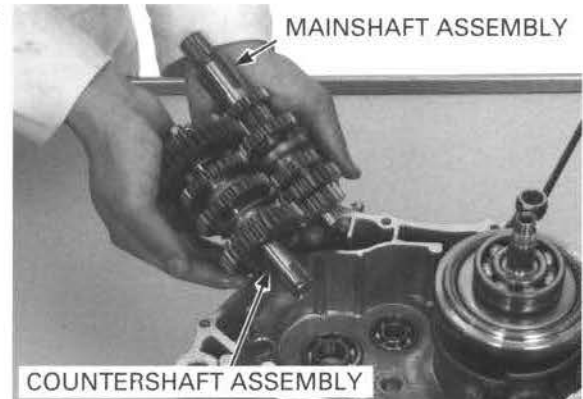

Install the shift drum into the left crankcase.



Install the shift forks. *Install the shift forks into the shifter gear grooves with their marks facing up.*

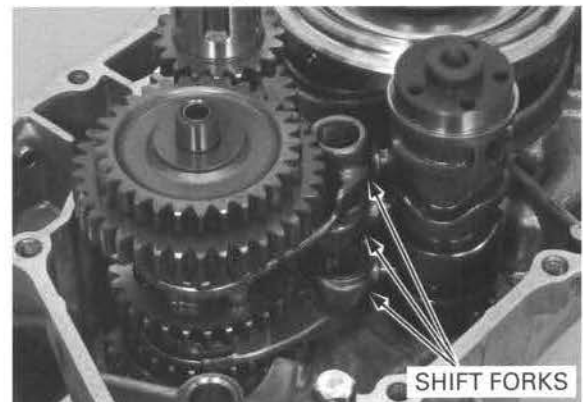

## CRANKSHAFT/TRANSMISSION/KICKSTARTER

Install the shift fork shaft.

Rotate the mainshaft by hand to see if the gears rotate freely.

Install the following:

- Kickstarter spindle (page 11-19).
- Assemble the crankcase (page 11-19).

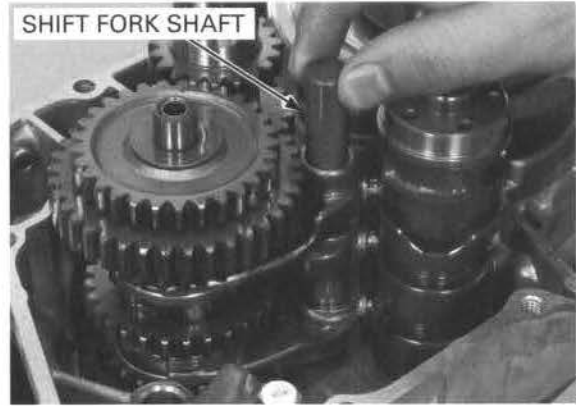

## KICKSTARTER

### REMOVAL/DISASSEMBLY

Separate the crankcase (page 11-7).

Remove the kickstarter spindle from the left crankcase.

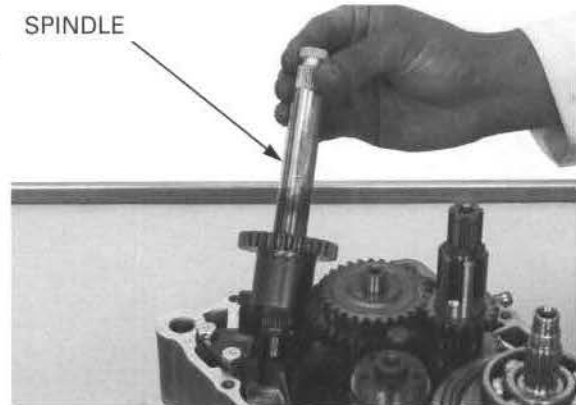

Remove the two washers and kickstarter pinion.

Remove the snap ring then remove the starter ratchet, ratchet spring and snap ring.

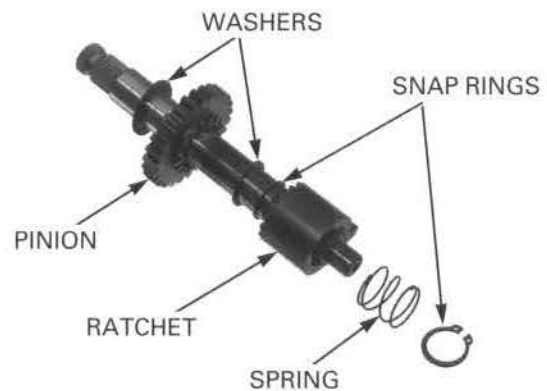

### INSPECTION

Check the kickstarter spindle for straightness.  
Check the return spring for fatigue.  
Measure the pinion gear I.D.

**SERVICE LIMIT: 18.06 mm (0.711 in)**

Measure the kickstarter spindle O.D.

**SERVICE LIMIT: 17.88 mm (0.704 in)**





**ASSEMBLY/INSTALLATION**

Install the snap ring.

Install the starter ratchet aligning its punch mark with the kickstarter spindle.

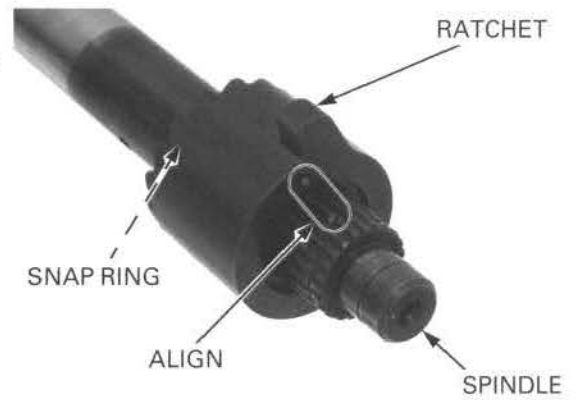

Install the ratchet spring and snap ring.

Install the pinion and two washers.

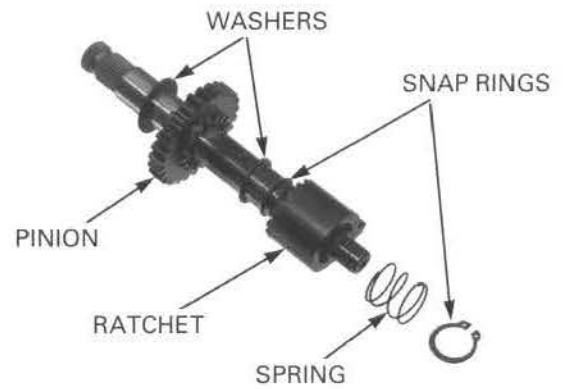

Install the kickstarter spindle to the left crankcase.

Assemble the crankcase (page 11-19).

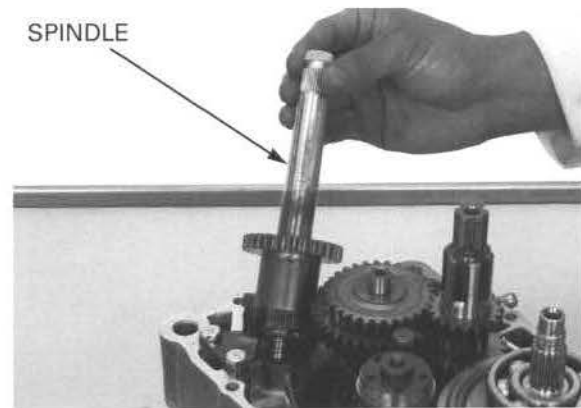

**CRANKCASE ASSEMBLY**

*Be careful not to damage the crankcase mating surface.*

Clean off any gasket material from the crankcase mating surface before assembling.

Dress the surfaces with an oil stone if necessary to correct any minor roughness or irregularities.

After cleaning, lubricate the crankshaft bearings and other contacting surfaces with clean engine oil.

Install the dowel pins and new gasket onto the left crankcase.

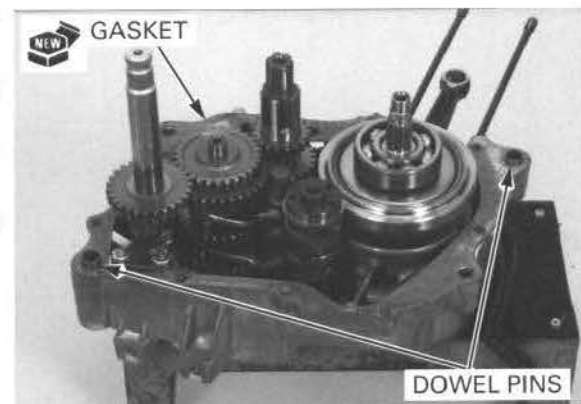

## CRANKSHAFT/TRANSMISSION/KICKSTARTER

*Make sure that the gasket stays in place.*

Assemble the right crankcase over the left crankcase, being careful to align the dowel pins and shafts.

Do not force the crankcase halves together; if there is excessive force required, something is wrong. Remove the right crankcase and check for misaligned parts.

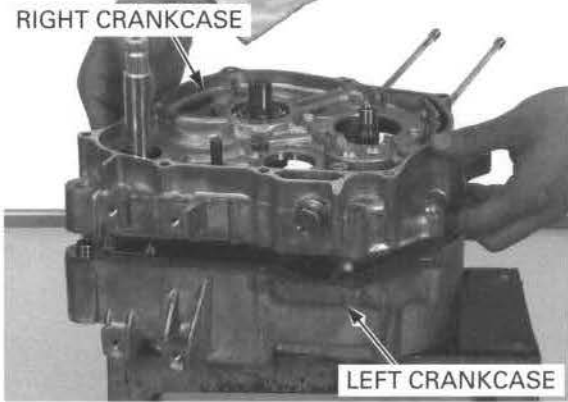

Install and tighten the two right crankcase bolts.

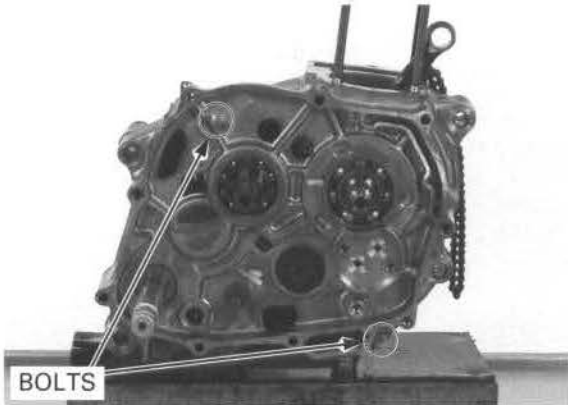

Install the return spring end into the hole on kickstarter spindle.

Install the spring collar aligning its groove with the return spring end.

Hook the return spring end on the crankcase boss.

Install the removed parts in the reverse order of removal.

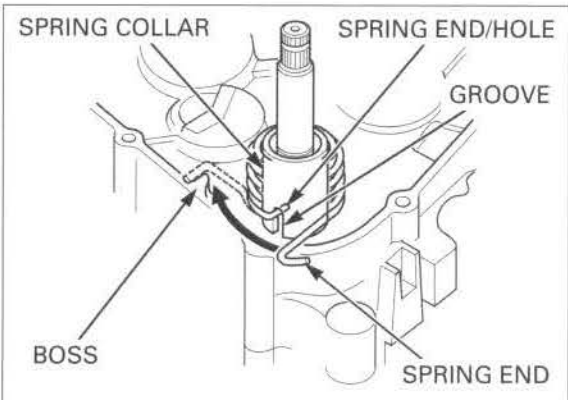
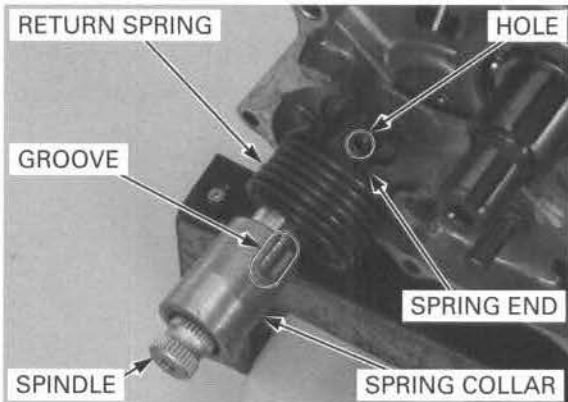

# 12. FRONT WHEEL/BRAKE/SUSPENSION/STEERING

---

COMPONENT LOCATION .....	12-2	FRONT WHEEL .....	12-10
SERVICE INFORMATION .....	12-3	FRONT BRAKE.....	12-15
TROUBLESHOOTING .....	12-5	FORK .....	12-18
HANDLEBAR .....	12-6	STEERING STEM.....	12-26

COMPONENT LOCATION

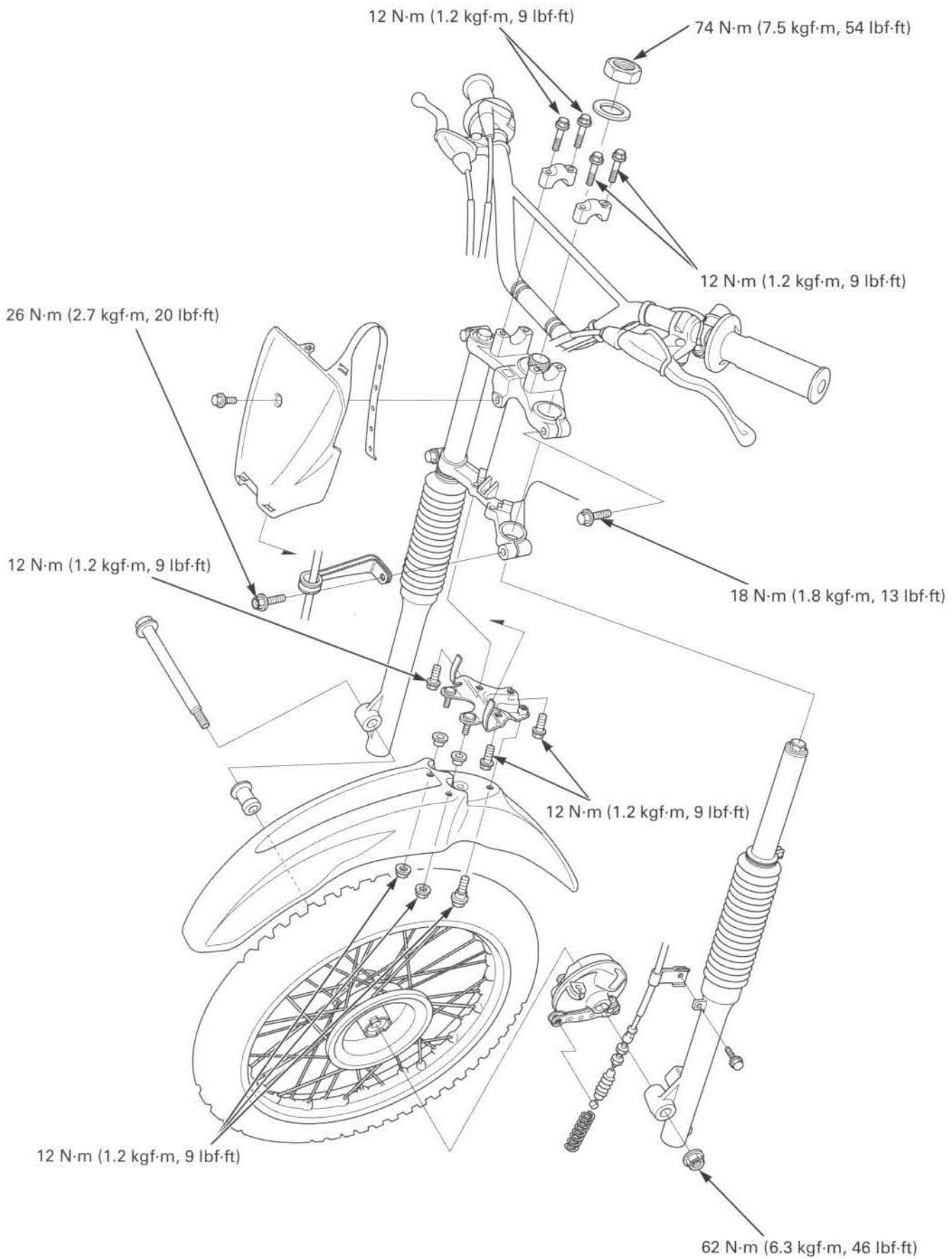

## SERVICE INFORMATION

### GENERAL

#### ⚠ CAUTION

Frequent inhalation of brake shoe dust, regardless of material composition could be hazardous to your health.

- Avoid breathing dust particles.
- Never use an air hose or brush to clean brake assemblies. Use an OSHA-approved vacuum cleaner.

- Riding on damaged rims impairs safe operation of the motorcycle.
- When servicing the front wheel, brake, fork or steering stem, support the motorcycle using a safety stand or hoist.

### SPECIFICATIONS

Unit: mm (in)







ITEM		STANDARD	SERVICE LIMIT	
Front wheel	Cold tire pressure	100 kPa (1.00 kgf/cm <sup>2</sup> , 14 psi)	-	
	Front wheel rim runout	Radial	-	
		Axial	-	
	Wheel hub-to-rim distance	12.0 ± 1.0	-	
	Front axle runout	-	0.20 (0.008)	
Brake	Lining thickness	4.0 (0.16)	2.0 (0.08)	
	Drum I.D.	95.0 (3.74)	96.0 (3.78)	
Fork	Spring free length	CRF100F	546.0 (21.50)	
		CRF80F	531.2 (20.91)	
	Fork pipe runout	-	0.20 (0.008)	
	Recommended fork fluid	Pro Honda suspension Fluid SS-8 (10W)	-	
	Fluid level	CRF100F	207.0 (8.15)	-
		CRF80F	177.0 (6.97)	-
Fluid capacity	CRF100F	84 ± 2.5 cm <sup>3</sup> (2.8 ± 0.08 US oz, 3.0 ± 0.09 Imp oz)	-	
	CRF80F	85 ± 2.5 cm <sup>3</sup> (2.9 ± 0.08 US oz, 3.0 ± 0.09 Imp oz)	-	

### TORQUE VALUES

Handlebar upper holder bolt	12 N·m (1.2 kgf·m, 9 lbf·ft)	
Front axle nut	62 N·m (6.3 kgf·m, 46 lbf·ft)	U-nut
Front brake arm pinch bolt	10 N·m (1.0 kgf·m, 7 lbf·ft)	Apply a locking agent to the threads.
Steering stem lock nut	74 N·m (7.5 kgf·m, 54 lbf·ft)	
Steering stem bearing adjusting nut	-	See page 12-29
Fork bottom bridge pinch bolt	26 N·m (2.7 kgf·m, 20 lbf·ft)	
Fork top bridge pinch bolt	18 N·m (1.8 kgf·m, 13 lbf·ft)	
Fork socket bolt	20 N·m (2.0 kgf·m, 14 lbf·ft)	Apply a locking agent to the threads.
Spoke	3 N·m (0.3 kgf·m, 2 lbf·ft)	
Fork bolt	23 N·m (2.3 kgf·m, 17 lbf·ft)	
Fender stay bolt	12 N·m (1.2 kgf·m, 9 lbf·ft)	
Front fender bolt/nut	12 N·m (1.2 kgf·m, 9 lbf·ft)	

# FRONT WHEEL/BRAKE/SUSPENSION/STEERING

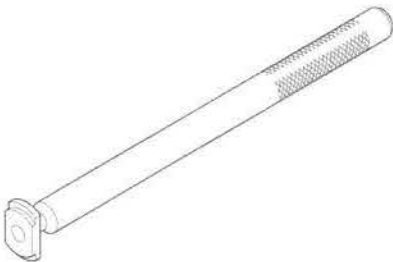
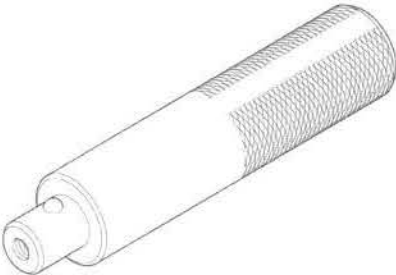
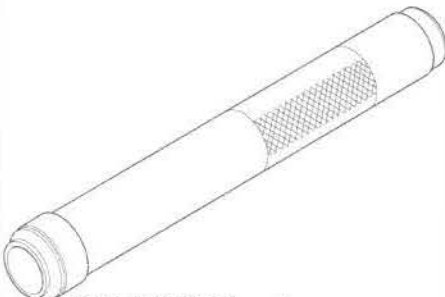
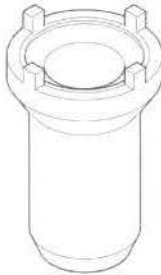
## TOOLS

<p>Pilot, 12 mm 07746-0040200</p> 	<p>Attachment, 32 x 35 mm 07746-0010100</p> 	<p>Attachment, 37 x 40 mm 07746-0010200</p> 
<p>Bearing remover shaft 07746-0050100</p> 	<p>Bearing remover head, 12 mm 07746-0050300</p> 	<p>Ball race remover 07944-1150001</p> 
<p>Driver 07749-0010000</p> 	<p>Steering stem driver, 24 mm 07946-GC40000</p>  <p>or 07946-MB00000 and 07946-GC4000A (U.S.A. only)</p>	<p>Lock nut wrench 07916-3710101</p>  <p>or 07916-3710100 (U.S.A. only)</p>
<p>Fork seal driver 27 mm 07947-1180001</p> 	<p>Spoke wrench, 4.5 x 5.1 mm 07701-0020200</p>  <p>or equivalent commercially available in U.S.A.</p>	

---

## TROUBLESHOOTING



### Hard steering

- Steering stem adjusting nut too tight
- Faulty or damaged steering head bearing
- Insufficient tire pressure
- Faulty tire



### Steers to one side or does not track straight

- Bent fork
- Bent front axle
- Wheel installed incorrectly
- Faulty steering head bearings
- Bent frame
- Worn wheel bearings
- Worn swingarm pivot components
- Weak front shock absorber



### Front wheel wobbling

- Bent rim
- Worn front wheel bearings
- Faulty tire
- Unbalanced tire and wheel

### Front wheel hard to turn

- Faulty wheel bearings
- Bent front axle
- Brake drag

### Soft suspension



- Weak fork springs
- insufficient fluid in fork
- Low tire pressure



### Stiff suspension

- Incorrect fork fluid viscosity
- Bent fork pipes
- Clogged fluid passage

### Suspension noisy

- Low fork fluid level
  - Loose fork fasteners
- 
- 
- 
- 
- 

**HANDLEBAR**

**REMOVAL**

Remove the number plate (page 2-5).  
Remove the wire bands.

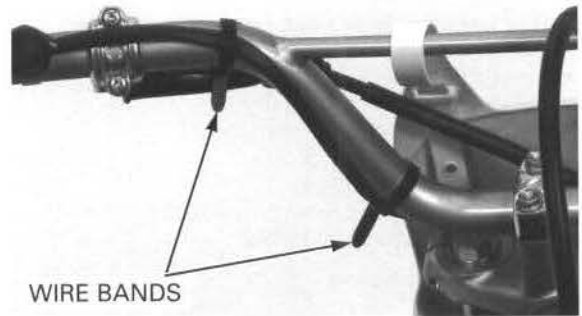

WIRE BANDS

Remove the two screws, holder and clutch lever bracket.

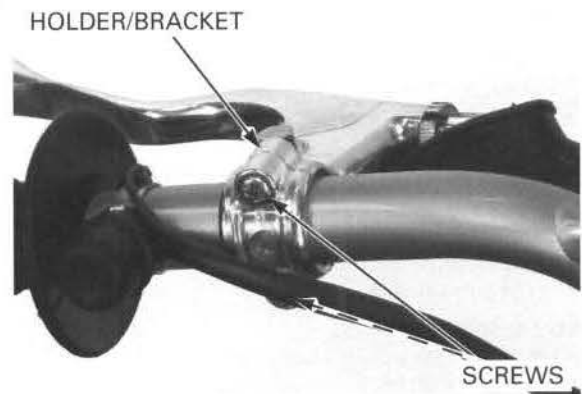

HOLDER/BACKET

SCREWS

Remove the screw, ground wire and engine stop button.

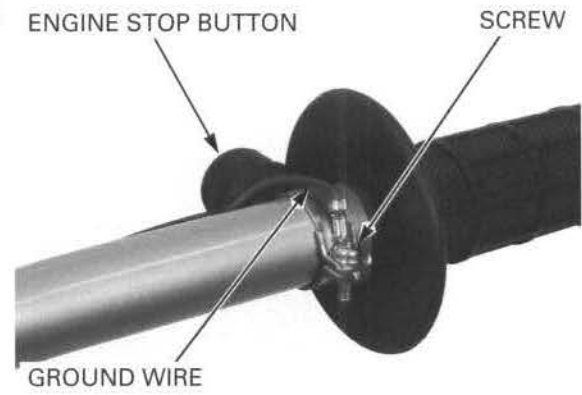

ENGINE STOP BUTTON

SCREW

GROUND WIRE

Remove the throttle housing screws and cover.

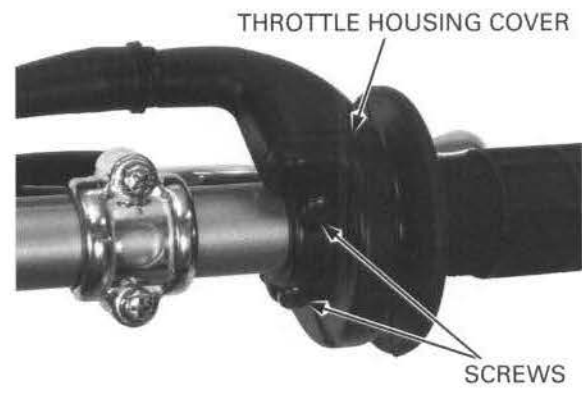

THROTTLE HOUSING COVER

SCREWS



Disconnect the throttle cable end from the throttle pipe and remove the throttle housing.

Remove the throttle pipe from the handlebar.

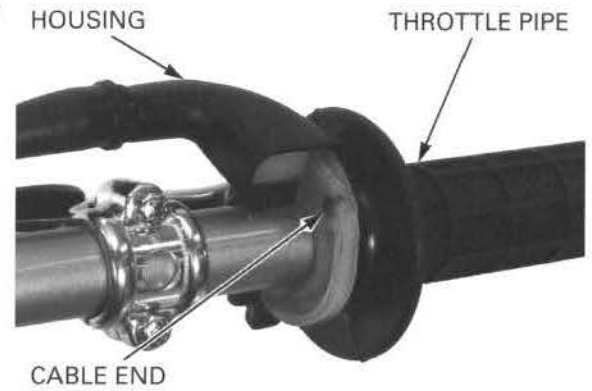

Remove the screws, holder and front brake lever bracket.

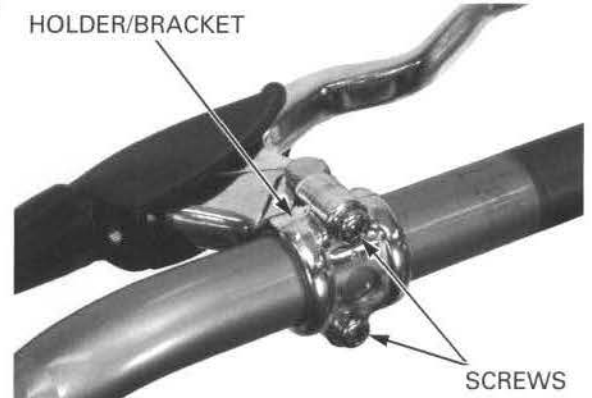

Remove the handlebar upper holder bolts and holders.

Remove the handlebar.

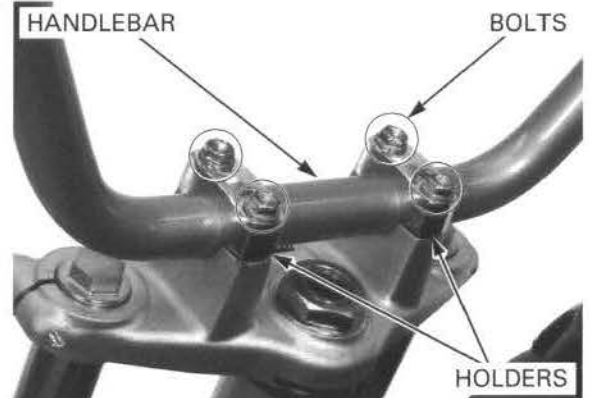

## INSTALLATION

Place the handlebar onto the lower holders, aligning the punch mark on the handlebar with the mating surface of the lower holder.

Place the upper holders with the punch marks facing forward.

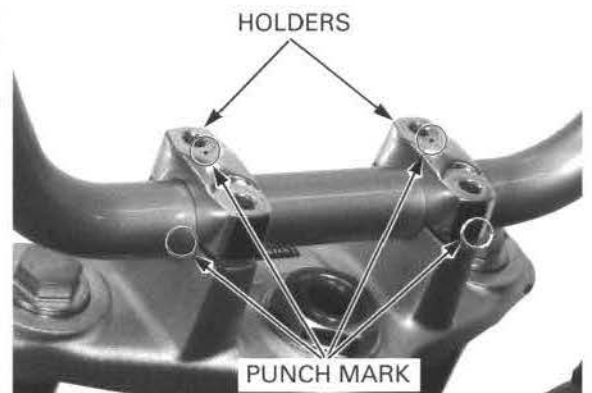

## FRONT WHEEL/BRAKE/SUSPENSION/STEERING

Install the upper holder bolts, tighten the forward bolts first, then the rear bolts.

**TORQUE: 12 N·m (1.2 kgf·m, 9 lbf·ft)**

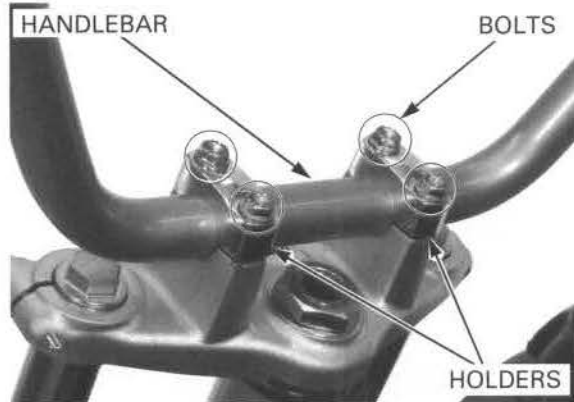

If the handlebar grips were removed, apply Honda Bond A or Pro Honda Hand Grip Cement (U.S.A. only) to the inside of the grip and to the clean surfaces of the left handlebar and throttle grip.

*Allow the adhesive to dry for an hour before using.*

Wait 3 – 5 minutes and install the grip.

Rotate the grip for even application of the adhesive.

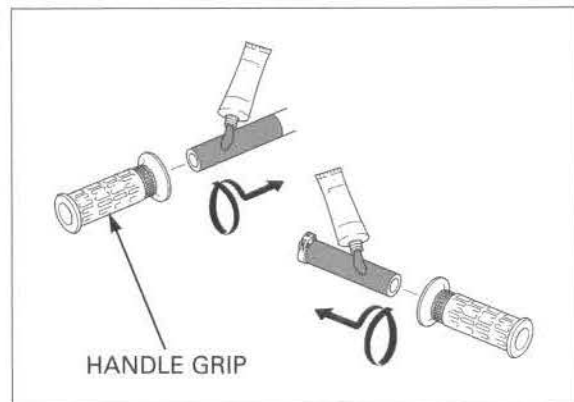

Place the front brake lever bracket onto the handlebar.

Install the holder with its punch mark facing up.

Align the mating surface of the bracket with the punch mark on the handlebar.

Tighten the upper screw first, then the lower screw.

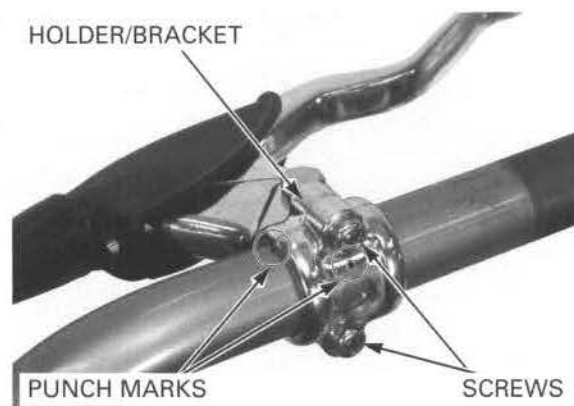

Apply grease to the sliding surface of the throttle pipe.

Install the throttle pipe on the handlebar.

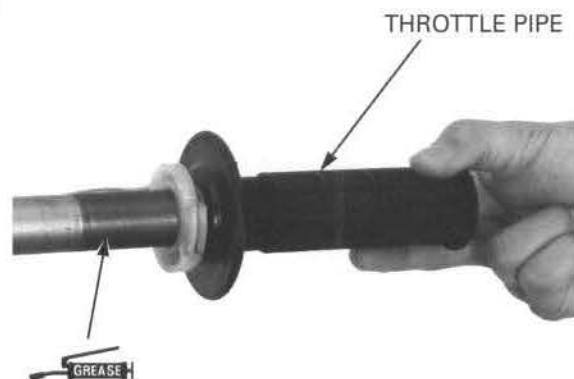

Apply oil to the throttle cable end and sliding surface.

Connect the throttle cable to the throttle pipe.

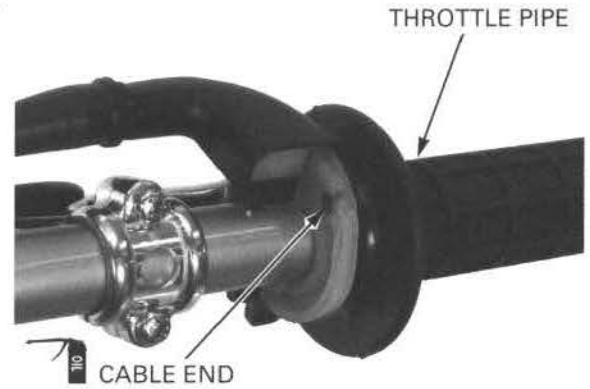

Align the mating surface of the throttle housing with the punch mark on the handlebar.

Install the throttle housing cover and tighten the upper screw first, then the lower screw.

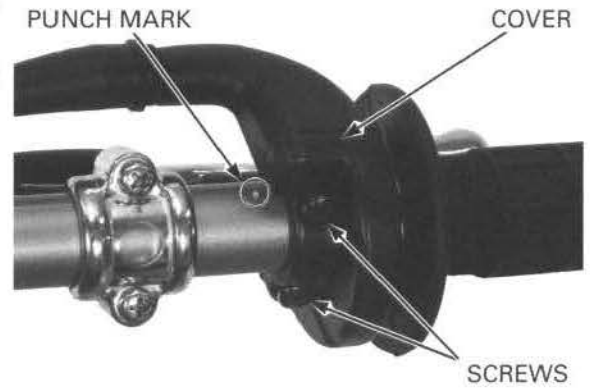

Install the engine stop button and ground wire, then align the mating surface of the clamp with the punch mark on the handlebar.

Tighten the screw securely.

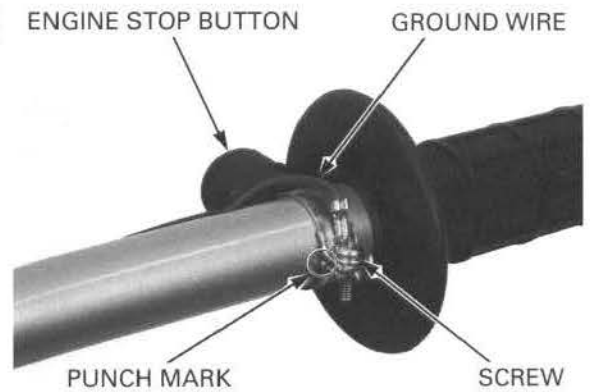

Place the clutch lever bracket onto the handlebar.

Install the holder with its punch mark facing up.

Align the mating surface of the bracket with the punch mark on the handlebar.

Tighten the upper screw first, then the lower screw.

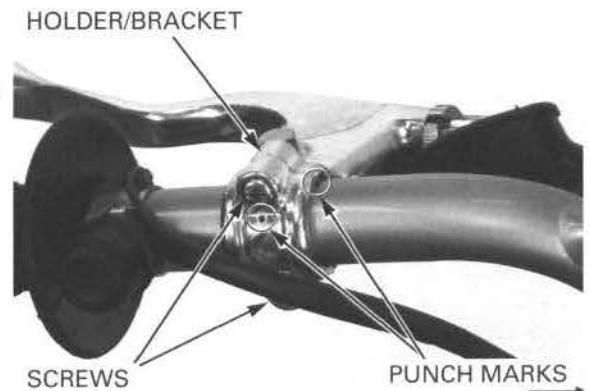

## FRONT WHEEL/BRAKE/SUSPENSION/STEERING

Secure the engine stop button wire with the wire bands.

Install the number plate (page 2-5).

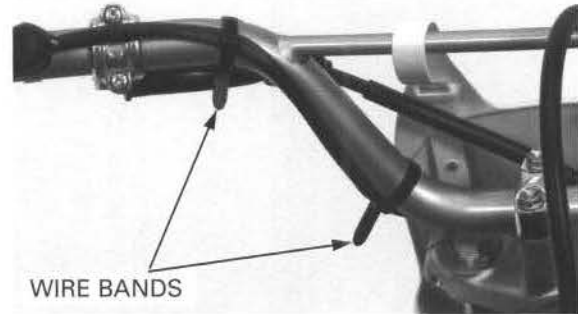

## FRONT WHEEL

### REMOVAL

Support the motorcycle securely using a safety stand or a hoist and raise the front wheel off the ground.

Remove the bolt and front brake cable guide from the left fork slider.

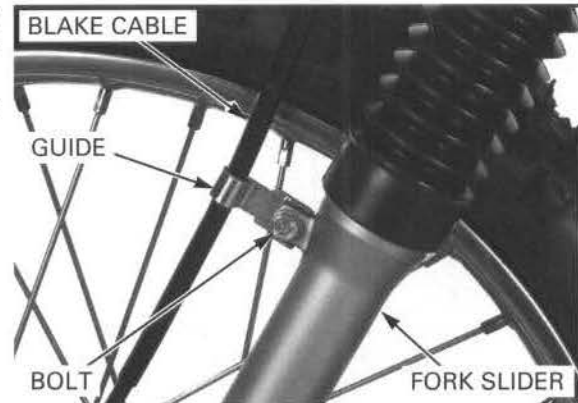

Remove the front axle nut, axle and front wheel.

Remove the brake panel from the front wheel.

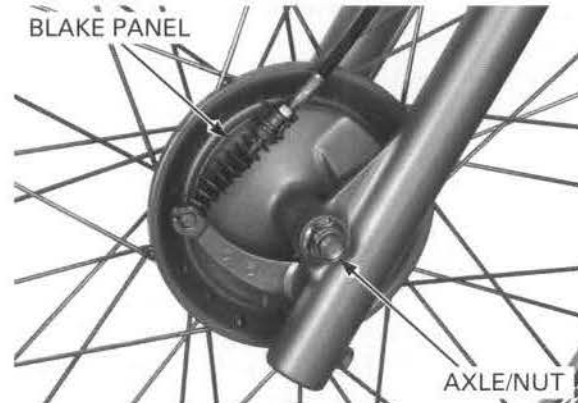

Remove the side collar from the right wheel hub.

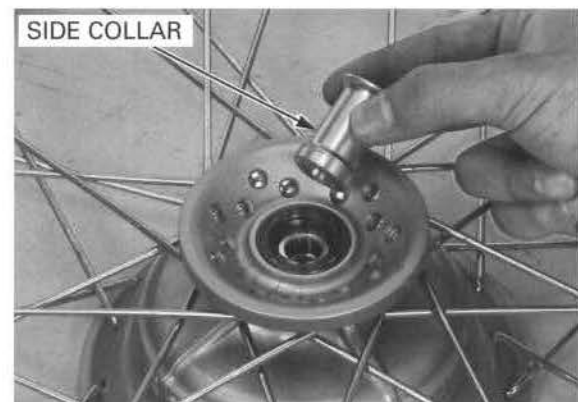

## INSPECTION

### Axle runout

Set the axle in V-blocks and measure the runout. Actual runout is 1/2 of the total indicator reading.

**SERVICE LIMIT: 0.20 mm (0.008 in)**

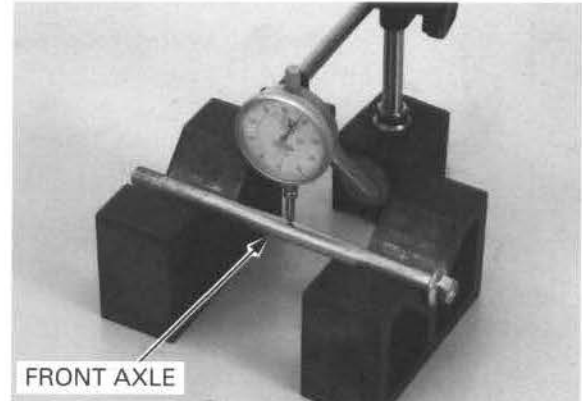

### Wheel rim

Check the rim runout by placing the wheel in a truing stand.

Spin the wheel by hand, and read the runout using a dial indicator.

Actual runout is 1/2 the total indicator reading.

### SERVICE LIMITS:

**Radial: 2.0 mm (0.08 in)**

**Axial: 2.0 mm (0.08 in)**

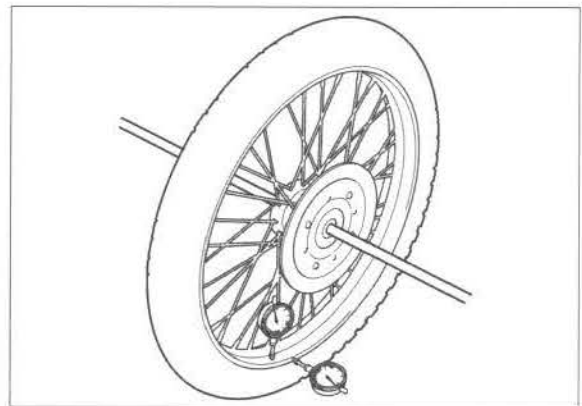

### Wheel bearing

Turn the inner race of each bearing with your finger.

Also check that the bearing outer race fits tightly in the hub.

The bearings should turn smoothly and quietly.

*Replace the bearings in pairs.*

Remove and discard the bearings if they do not turn smoothly, quietly, or if they fit loosely in the hub.

Install the new bearings into the hub using the special tools (page 12-12).

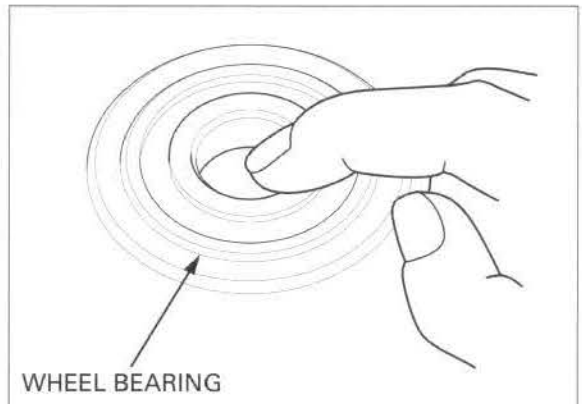

## DISASSEMBLY

Remove the dust seal from the right wheel hub.



## FRONT WHEEL/BRAKE/SUSPENSION/STEERING

Install the bearing remover head into the bearing.

From the opposite side, install the bearing remover shaft and drive the bearing out of the wheel hub.

Remove the distance collar and drive out the other bearing.

### TOOLS:

Bearing remover head, 12 mm 07746-0050300  
Bearing remover shaft 07746-0050100

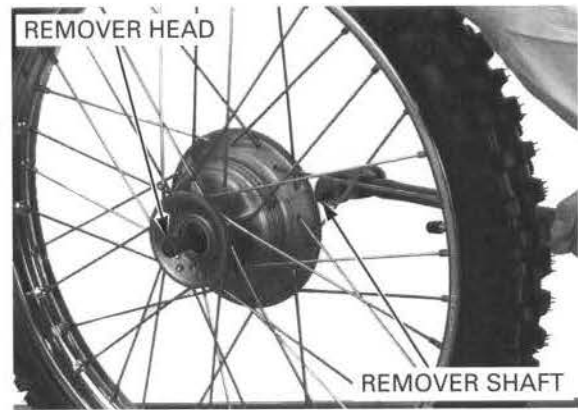

## ASSEMBLY

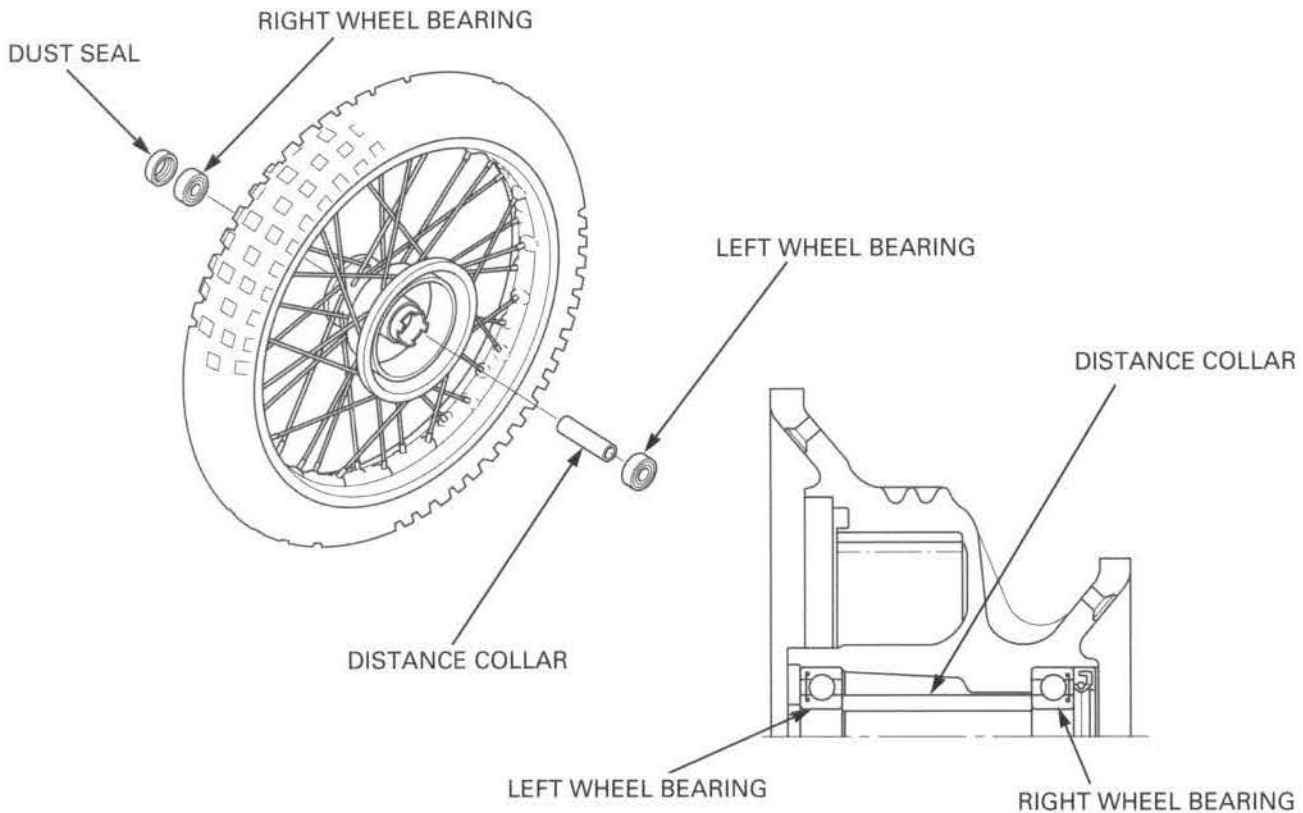

Pack the new bearing cavities with grease.

*Replace the wheel bearings in pairs. Do not reuse old bearings.*

Drive in a new right side bearing squarely with its sealed side facing out.

Install the distance collar, then drive in the left side bearing with its sealed side facing out.

### TOOLS:

Driver 07749-0010000  
Attachment, 32 x 35 mm 07746-0010100  
Pilot, 12 mm 07746-0040200

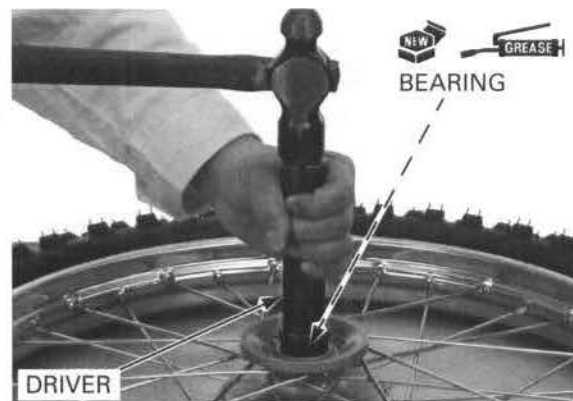

*Wheel center adjustment is necessary when new spokes are installed.*

**Wheel center adjustment**

Place the rim on the work bench and begin lacing with new spokes. Tighten the spokes in 2 or 3 progressive steps to the specified torque.

**TOOL:**

**Spoke wrench, 4.5 x 5.1 mm**      **07701-0020200 or equivalent commercially available in U.S.A.**

**TORQUE: 3 N-m (0.3 kgf-m, 2 lbf-ft)**

Adjust the hub position so that the distance from the right end surface of the hub center to the side of rim is  $12.0 \pm 1.0$  mm ( $0.47 \pm 0.04$  in) as shown.

Recheck the rim runout (page 12-11).

Apply grease to a new dust seal lips, and install the dust seal into the right wheel hub.

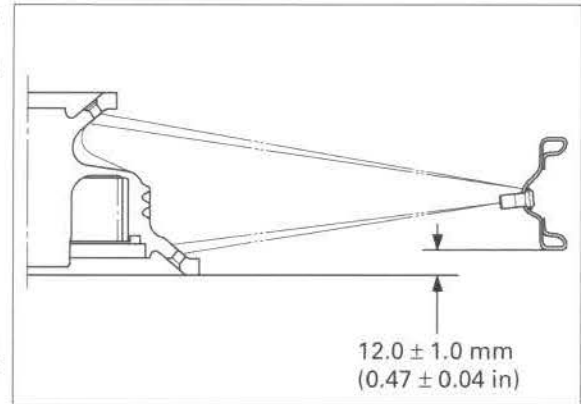

**INSTALLATION**

Install the side collar into the right wheel hub.

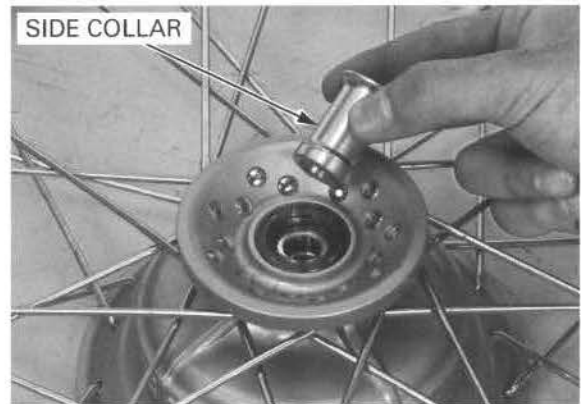

Install the brake panel into the front wheel.

Install the front wheel between the fork legs while aligning the brake panel groove with the boss on the left fork slider.

Apply a thin coat of grease to the front axle surface, then install the front axle from right side.

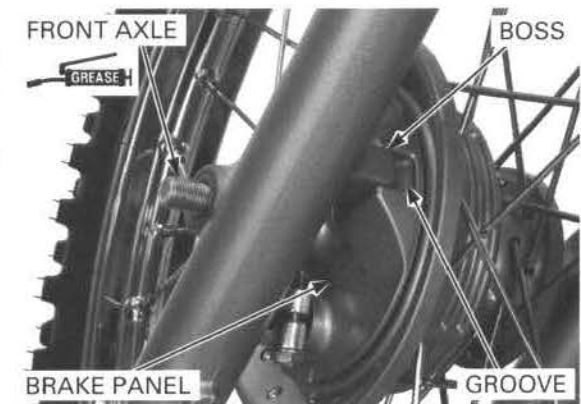



## FRONT WHEEL/BRAKE/SUSPENSION/STEERING

Hold the axle and temporarily tighten the axle nut.  
Adjust the front brake lever free play (page 3-20).



With the front brake applied, pump the fork up and down several times to seat the axle and check the front brake operation.



Tighten the axle nut to the specified torque.  
**TORQUE: 62 N·m (6.3 kgf·m, 46 lbf·ft)**



Install the brake cable guide to the left fork slider and tighten the bolt securely.

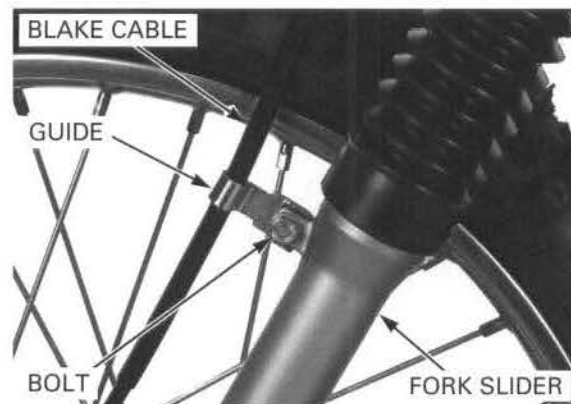



## FRONT BRAKE

### REMOVAL

Remove the front wheel (page 12-10).  
Disconnect the brake cable from the brake arm.

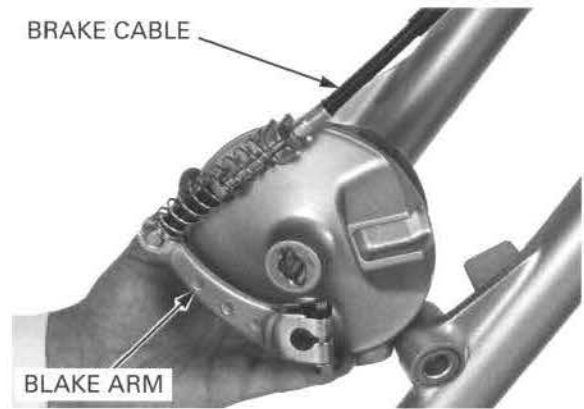

### INSPECTION

Measure the front brake drum I.D.

**SERVICE LIMIT: 96.0 mm (3.78 in)**



Measure the brake lining thickness.

**SERVICE LIMIT: 2.0 mm (0.08 in)**



### DISASSEMBLY

Remove the brake shoes and springs.

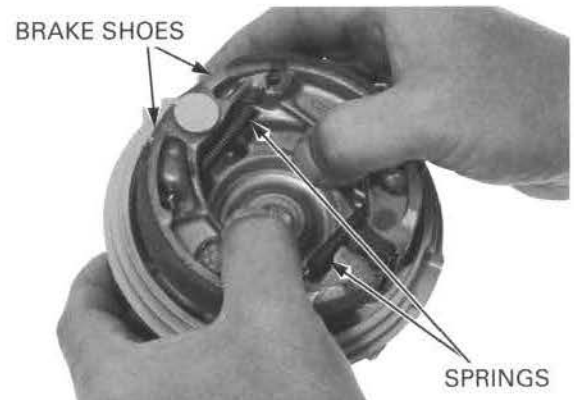

# FRONT WHEEL/BRAKE/SUSPENSION/STEERING

Remove the brake arm pinch bolt, nut and brake arm.

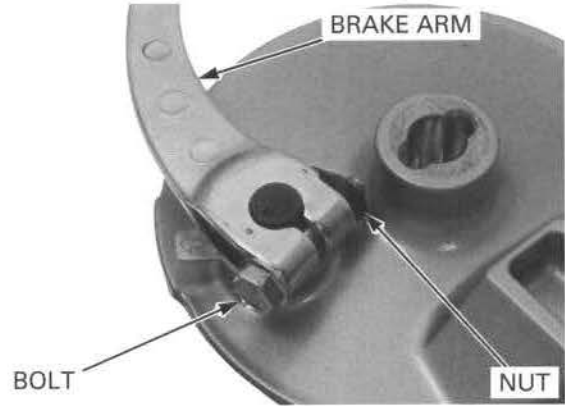

Remove the indicator plate, brake cam and dust seal.

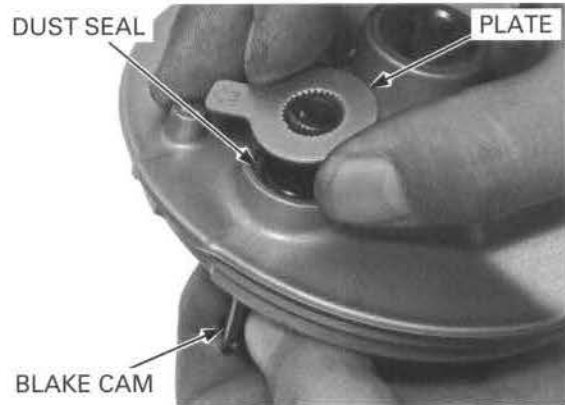

## ASSEMBLY

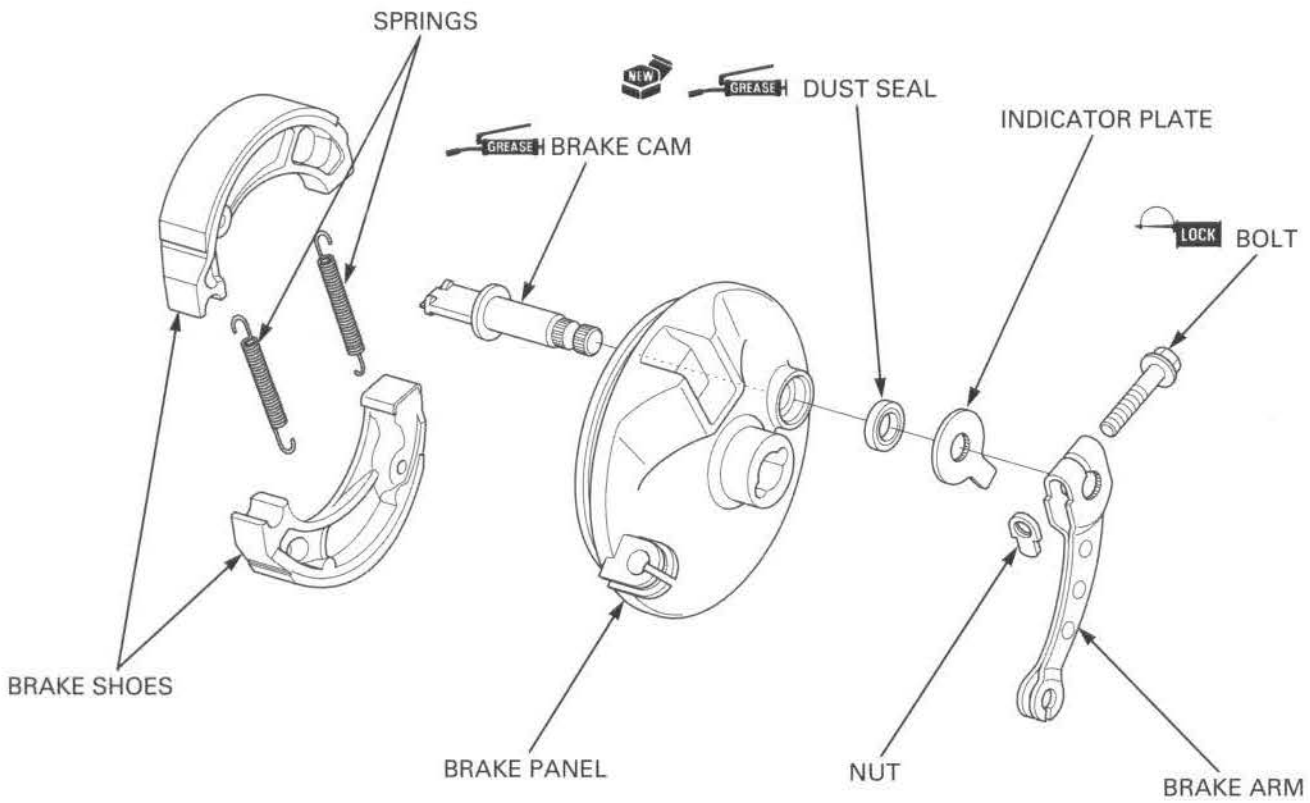

Apply grease to the dust seal and install it onto the brake panel.

Apply grease to the anchor pin and brake cam.

Install the brake cam into the brake panel.



Install the wear indicator plate on the brake cam aligning its wide tooth with the wide groove on the brake cam.

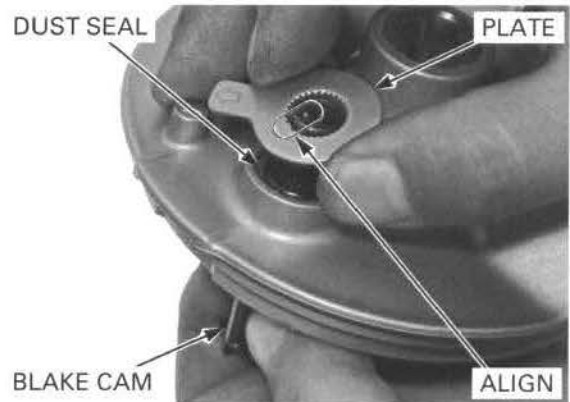

Install the brake arm aligning the punch marks between the arm and brake cam.

Apply a locking agent to the brake arm pinch bolt threads.

Install the brake arm pinch bolt and brake arm nut.

Tighten the bolt to the specified torque.

**TORQUE: 10 N·m (1.0 kgf·m, 7 lbf·ft)**

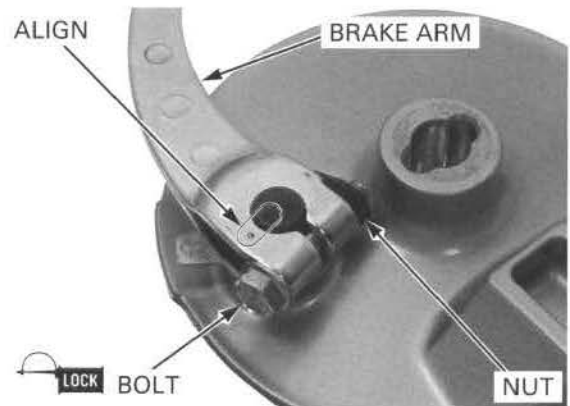

Install the brake shoes and springs.

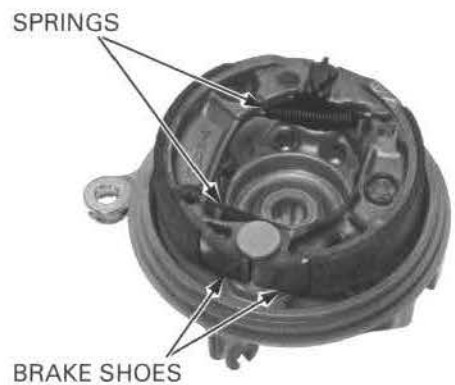

### INSTALLATION

Install the brake cable to the brake arm.

Install the front wheel (page 12-13).

Adjust the front brake lever free play (page 3-20).

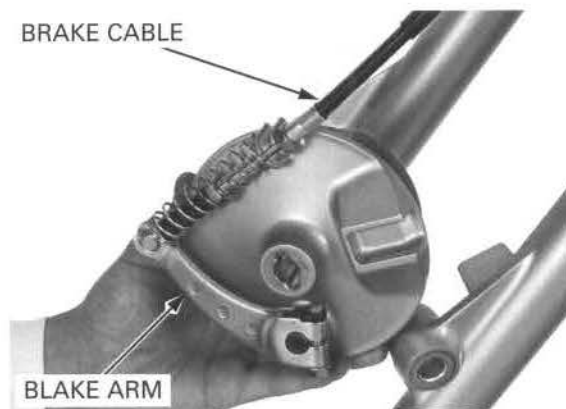

## FORK

### REMOVAL

Remove the number plate (page 2-5).

Remove the front wheel (page 12-10).

Loosen the fork top bridge pinch bolts.

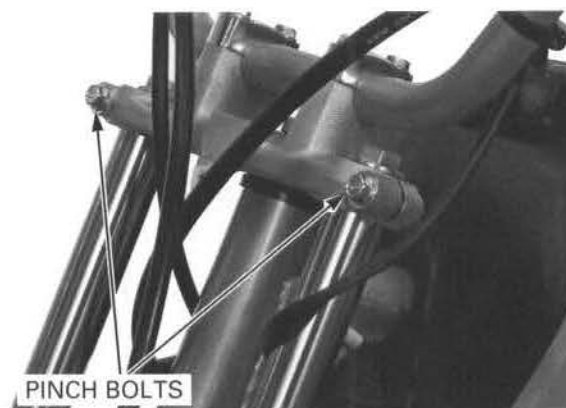

Loosen the fork bottom bridge pinch bolts.

Remove the fork leg.

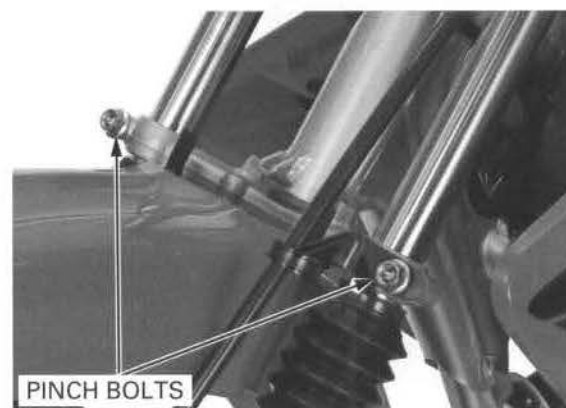

When the fork is to be disassembled, lower the fork leg and tighten the bottom pinch bolt.

Loosen the fork bolt, but do not remove it yet.

Loosen the fork bottom pinch bolt and remove the fork leg.

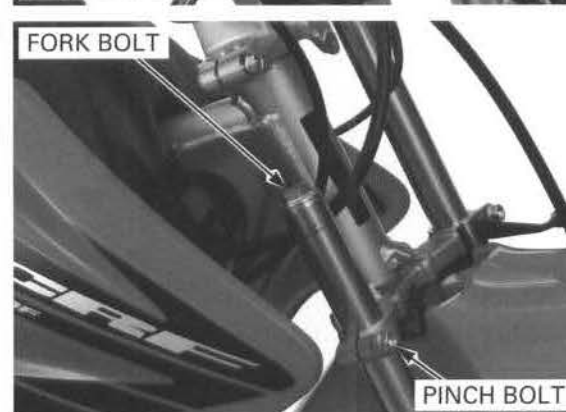

**DISASSEMBLY**

Loosen the fork boot clamp screw and remove the band and boot.

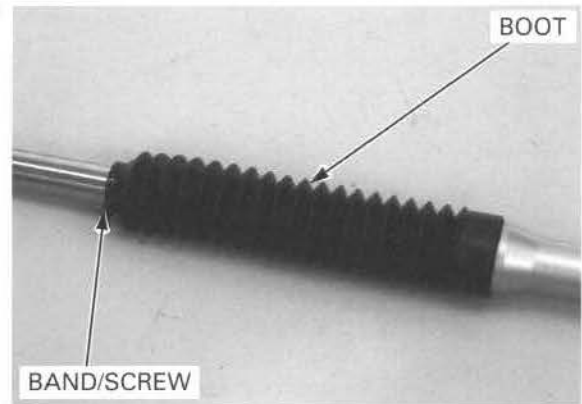

*The fork bolt is under spring pressure. Use care when removing it.*

Remove the fork bolt and O-ring.



Remove the fork spring.

Pour out the fork fluid by pumping the fork pipe up and down several times.

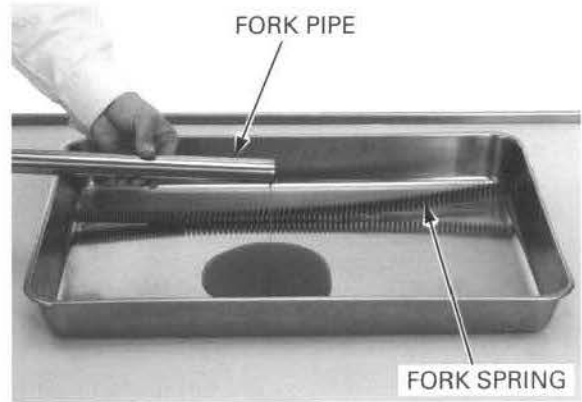

Hold the fork slider in a vice with soft jaws or a shop towel.

*If the fork piston turns with the socket bolts, temporarily install the fork spring and fork cap.*

Remove the fork socket bolt and sealing washer with a hex wrench.

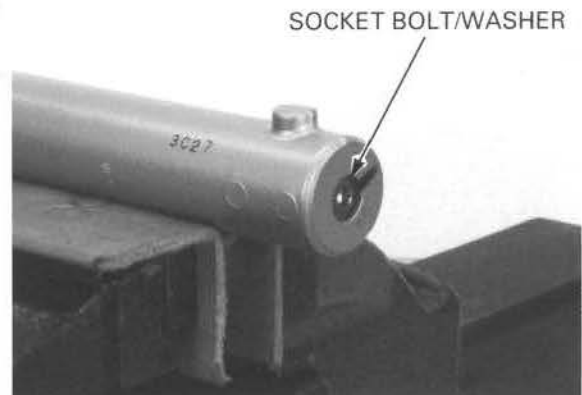

## FRONT WHEEL/BRAKE/SUSPENSION/STEERING

Remove the dust seal from the fork slider.

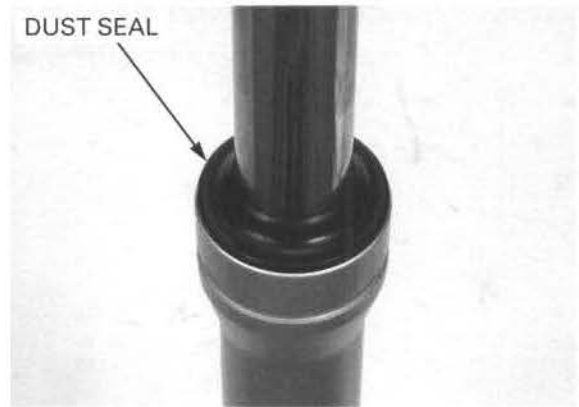

Remove the stopper ring from the fork slider.



Pull the fork pipe out from the fork slider.  
Remove the oil lock piece.

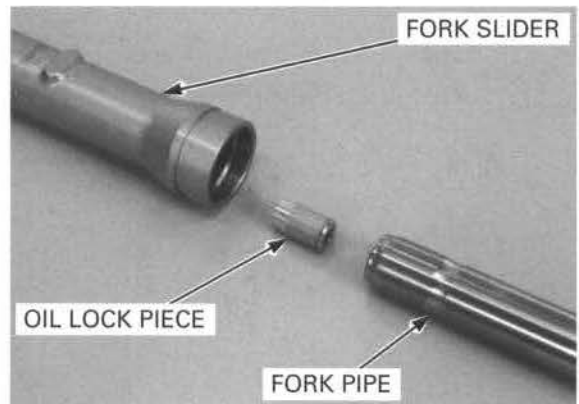

Remove the fork piston and rebound spring from the fork pipe.

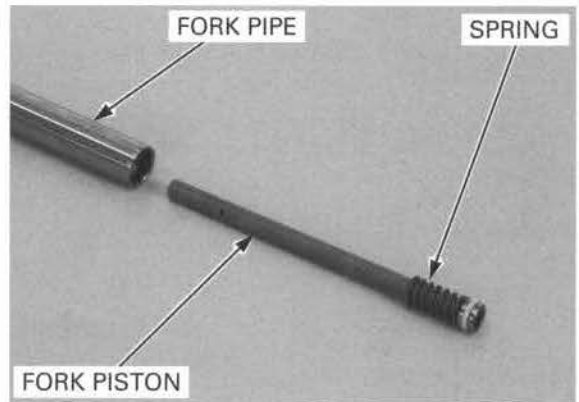

Remove the fork oil seal from the fork slider.

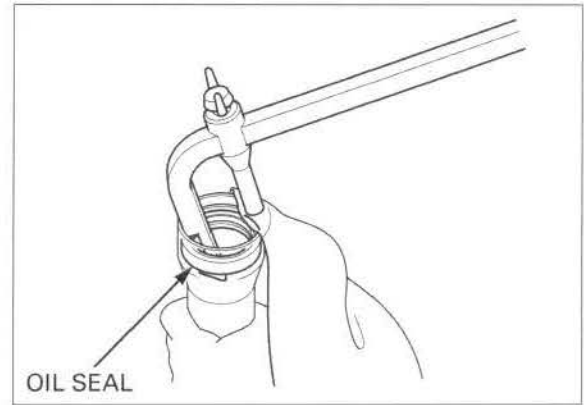

**INSPECTION**

**Fork spring**

Measure the fork spring free length.

**SERVICE LIMITS:**

CRF100F: 535.0 mm (21.06 in)

CRF80F: 520.7 mm (20.50 in)

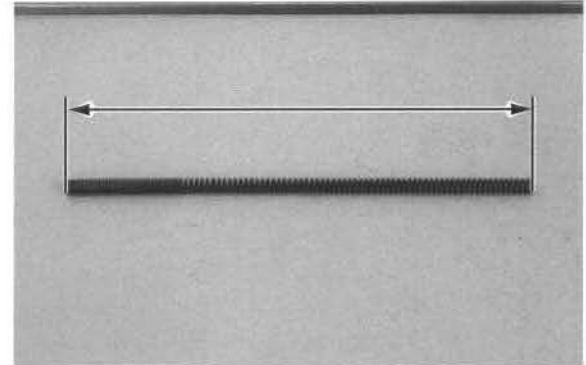

**Fork pipe/fork slider/piston**

Check the fork pipe and fork slider for score marks and excessive or abnormal wear.

Replace the components if necessary.

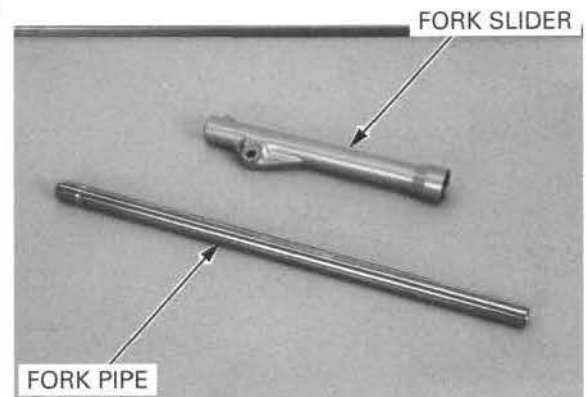

**Fork piston**

*Do not remove the fork piston ring except to replace it with a new one.*

Check the fork piston ring for wear or damage.

Check the rebound spring for fatigue or damage.

Replace the components if necessary.

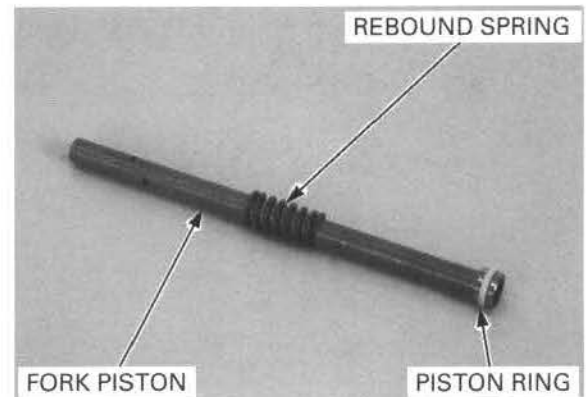

# FRONT WHEEL/BRAKE/SUSPENSION/STEERING

## Fork pipe runout

Place the fork pipe in V-blocks and measure the runout.

Actual runout is 1/2 the total indicator reading.

**SERVICE LIMIT: 0.20 mm (0.008 in)**

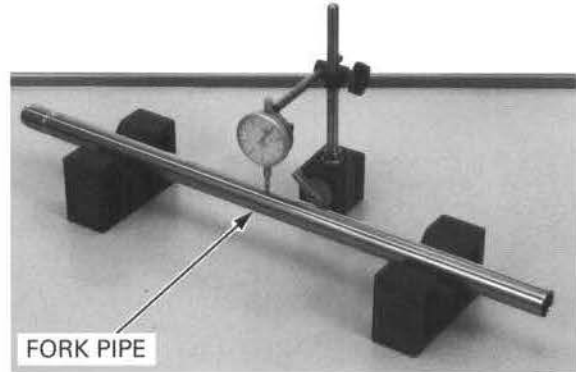

## ASSEMBLY

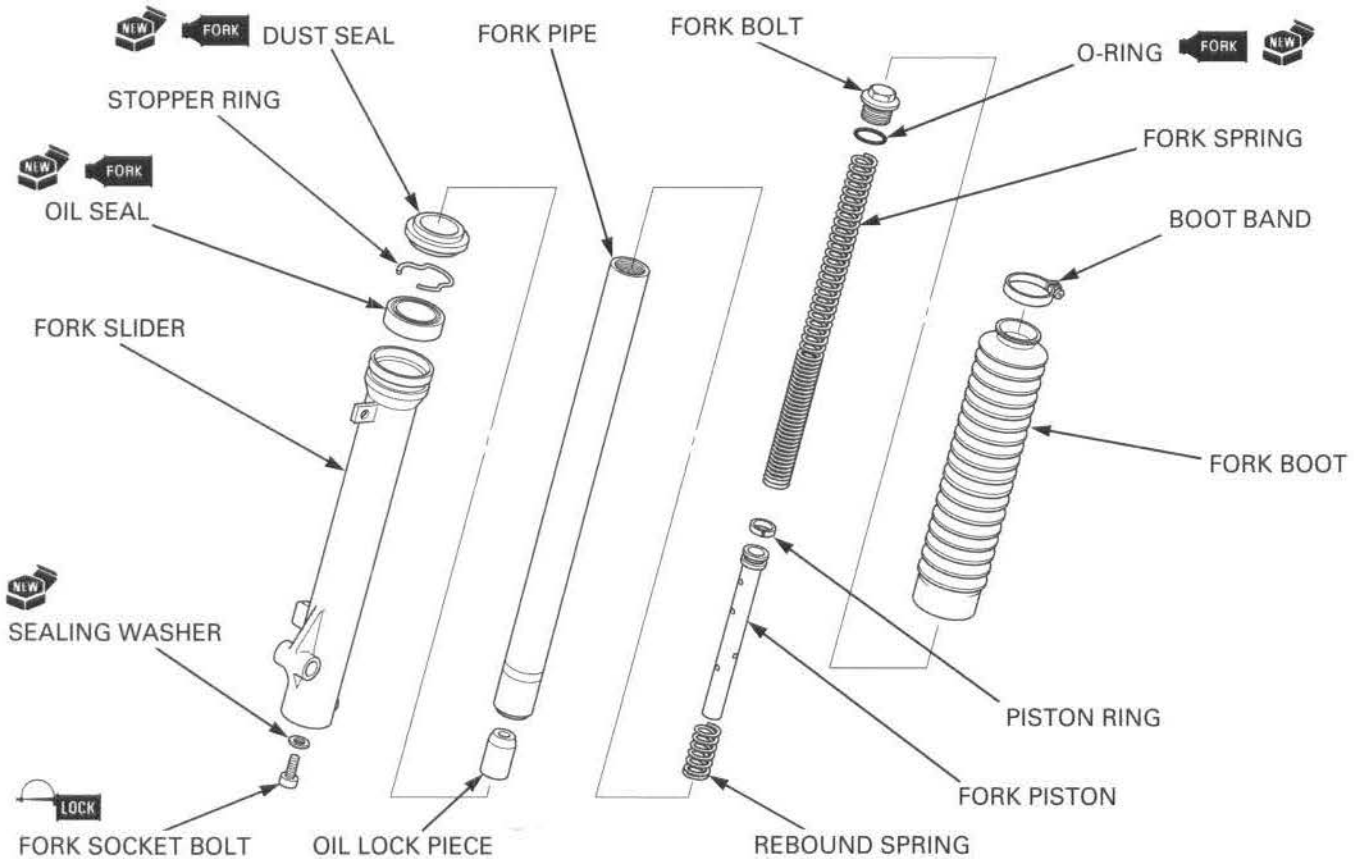

Before assembly, wash all parts with a high flash or non-flammable solvent and wipe them dry.

Install the rebound spring and fork piston into the fork pipe.

Install the oil lock piece to the end of the fork piston.

Install the fork pipe into the fork slider.

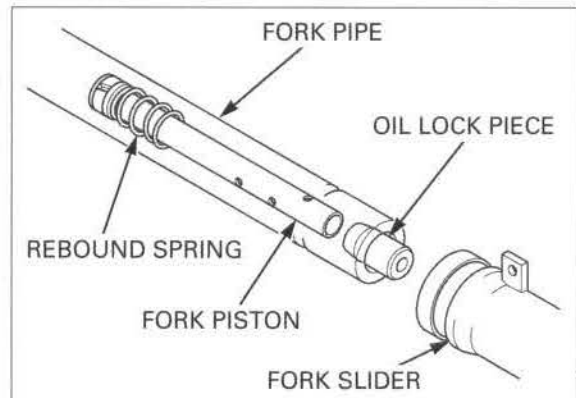



Hold the fork slider in a vise with soft jaws or a shop towel.

Apply a locking agent to the fork socket bolt threads.

*If the fork piston turns together with the socket bolt, temporarily install the fork spring and fork cap.*

Install and tighten the socket bolt with a new sealing washer into the fork piston.

**TORQUE: 20 N·m (2.0 kgf·m, 14 lbf·ft)**

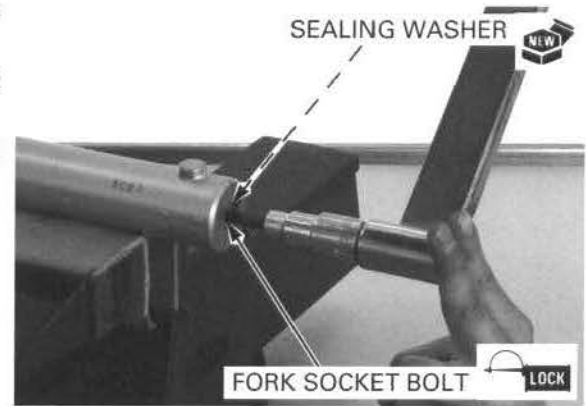

Wrap vinyl tape around the fork top end to avoid pipe damaging the fork oil seal lips.

Coat a new fork oil seal lips with fork fluid and install it over the fork pipe with the marking side facing up.

Drive the fork oil seal into the fork slider using the special tools.

**TOOL:**

**Fork seal driver 27 mm                      07947-1180001**



Install the oil seal stopper ring into the fork slider groove securely.

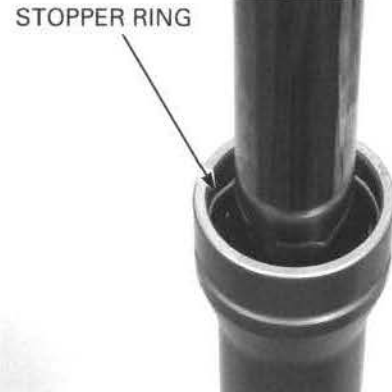

Apply fork fluid to a new dust seal lips and install it. Remove the vinyl tape from the fork pipe end.



## FRONT WHEEL/BRAKE/SUSPENSION/STEERING

Pour the specified amount of recommended fork fluid into the fork pipe.

### RECOMMENDED FORK FLUID:

Pro Honda Suspension Fluid SS-8 (10W)

### FORK FLUID CAPACITY:

CRF100F:  $84 \pm 2.5 \text{ cm}^3$   
( $2.8 \pm 0.08 \text{ US oz}$ ,  $3.0 \pm 0.09 \text{ Imp oz}$ )

CRF80F:  $85 \pm 2.5 \text{ cm}^3$   
( $2.9 \pm 0.08 \text{ US oz}$ ,  $3.0 \pm 0.09 \text{ Imp oz}$ )

Slowly pump the fork pipe several times to remove trapped air from the lower portion of the fork pipe.

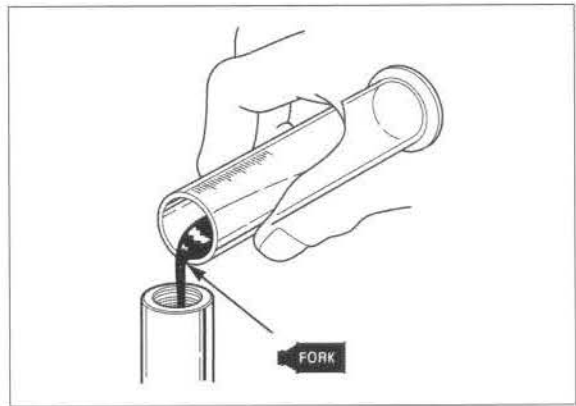

*Be sure the oil level is the same in both fork pipes.*

Compress the fork leg fully and measure the oil level from the top of the fork pipe.

### FORK FLUID LEVEL:

CRF100F: 207.0 mm (8.15 in)

CRF80F: 177.0 mm (6.97 in)

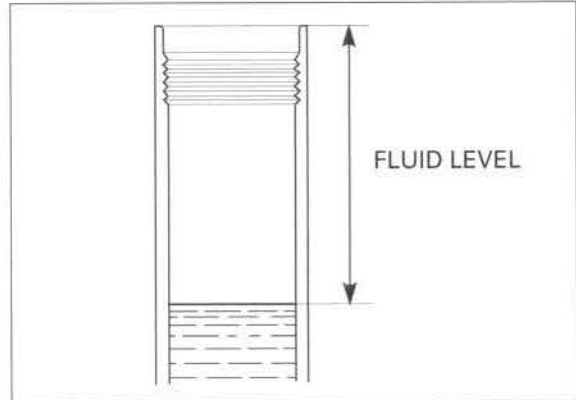

Pull the fork pipe up and install the fork spring with the tightly wound coil end facing down.

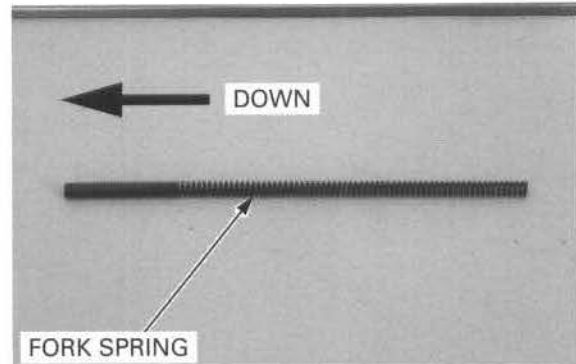

Coat a new O-ring with fork fluid and install it into the fork bolt groove.

Install the fork bolt into the fork pipe.

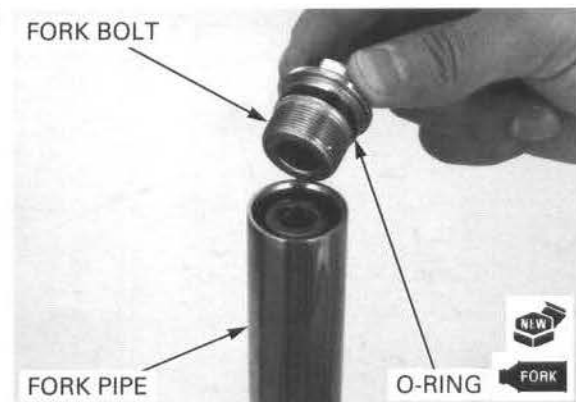

Install the fork boot and tighten the boot band screw loosely.

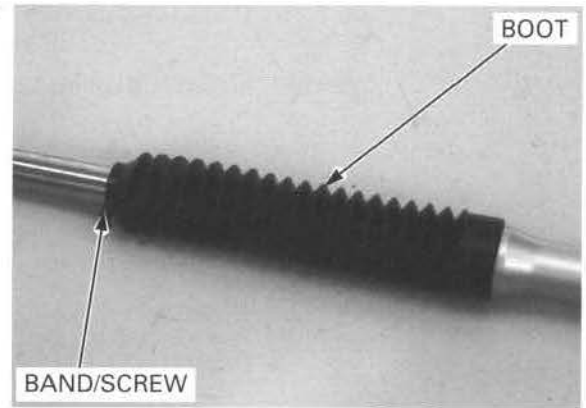

### INSTALLATION

Install the fork pipe into the steering stem.

If the fork has been reassembled, temporarily tighten the bottom bridge pinch bolts and tighten the fork bolt to the specified torque.

**TORQUE: 23 N·m (2.3 kgf·m, 17 lbf·ft)**

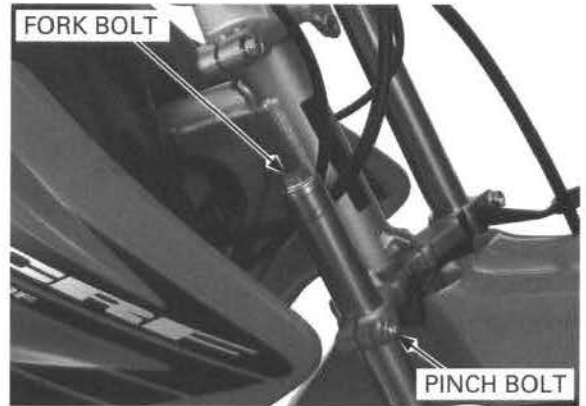

Loosen the bottom bridge pinch bolts and pull up the fork pipe to the top bridge.

Align the top end of the fork pipe with the upper surface of the top bridge as shown.

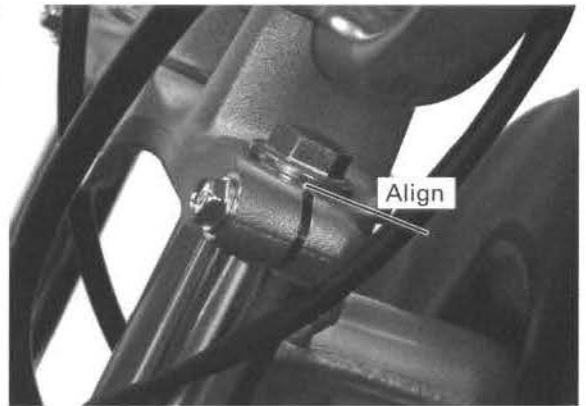

Tighten the bottom bridge pinch bolts to the specified torque.

**TORQUE: 26 N·m (2.7 kgf·m, 20 lbf·ft)**

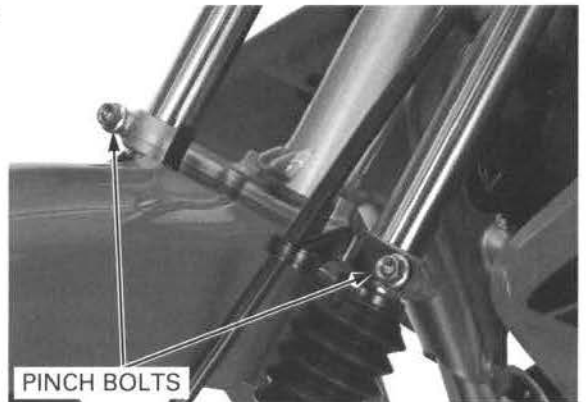

## FRONT WHEEL/BRAKE/SUSPENSION/STEERING

Tighten the top bridge pinch bolt to the specified torque.

**TORQUE: 18 N·m (1.8 kgf·m, 13 lbf·ft)**

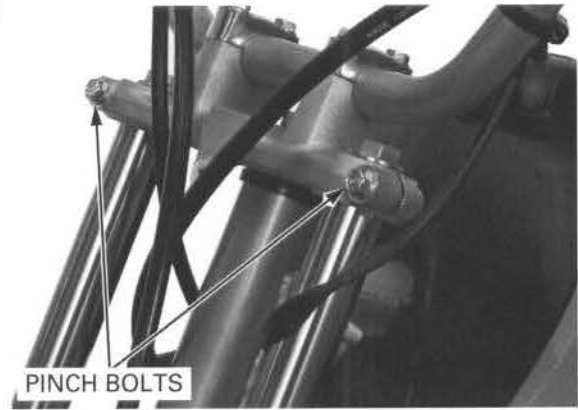

Pull the fork boot up until it just touches the bottom bridge.

Tighten the band screw with the band end facing rearward.

Install the front wheel (page 12-13).

Install the number plate (page 2-5).

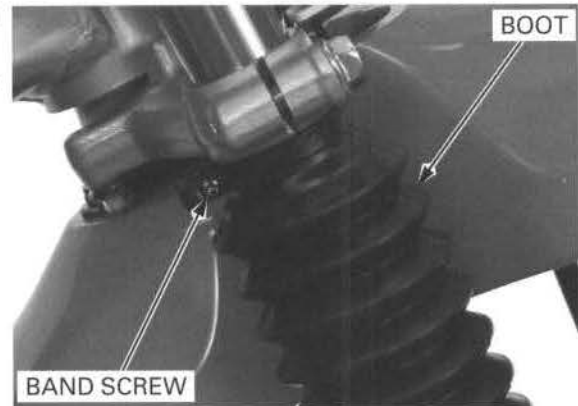

## STEERING STEM

### REMOVAL

Remove the following:

- Handlebar (page 12-6)
- Front wheel (page 12-10)
- Front fender (page 2-5)

Loosen the steering stem lock nut, then remove the fork legs (page 12-18), steering stem lock nut, washer and top bridge.



Remove the steering stem bearing adjusting nut using the special tool.

### TOOLS:

Lock nut wrench

07916-3710101 or  
07916-3710100  
(U.S.A. only)



Hold the bottom of steering stem to prevent it from falling out of the steering head, then remove the adjustment nut.

Remove the upper bearing inner race and upper bearing.



Remove the steering stem and lower bearing.

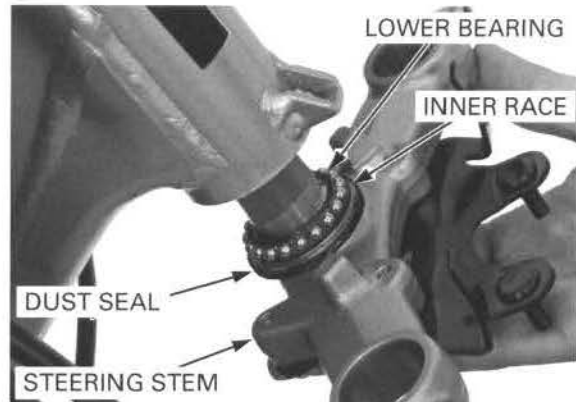

### BEARING RACE REPLACEMENT

*Always replace the bearings and races as a set.*

Remove the upper and lower bearing outer races using the special tools.

**TOOL:**  
**Ball race remover** 07944-1150001



*If the motorcycle has been involved in an accident, examine the area around the steering head for cracks.*

Install the new upper and lower bearing outer races using the special tool.

**TOOLS:**  
**Driver** 07949-0010000  
**Attachment, 37 x 40 mm** 07746-0010200

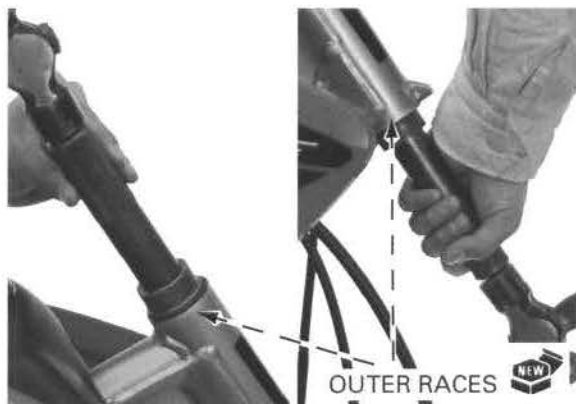

## FRONT WHEEL/BRAKE/SUSPENSION/STEERING

Remove the three bolts and fender stay.



Temporarily install the steering stem nut onto the stem to prevent the threads from being damaged when removing the lower bearing inner race from the stem.

Remove the lower bearing inner race with a chisel or equivalent tool, being careful not to damage the stem.

Remove the dust seal and washer.



Install the washer over the steering stem.

Apply grease to new dust seal lips and install it over the steering stem.

Install a new lower bearing inner race using a special tool and a hydraulic press.

### TOOLS:

Steering stem driver, 24 mm 07946-GC40000 or  
Steering stem driver, 30 mm 07946-MB00000 and  
Driver attachment, 24 mm 07746-GC4000A  
(U.S.A. only)

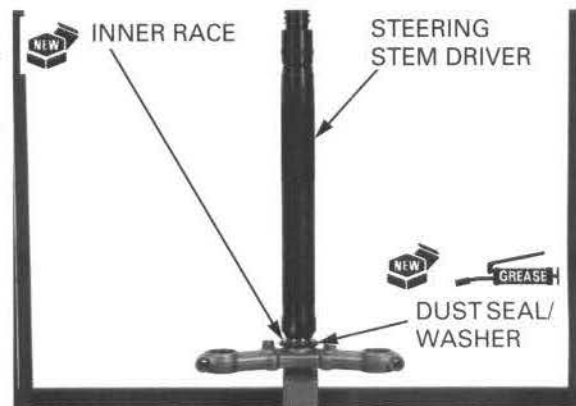

Install the fender stay.

Tighten the three bolts to the specified torque.

**TORQUE:** 12 N·m (1.2 kgf·m, 9 lbf·ft)

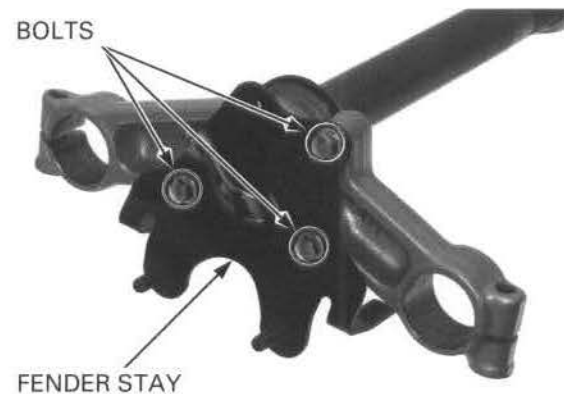

INSTALLATION

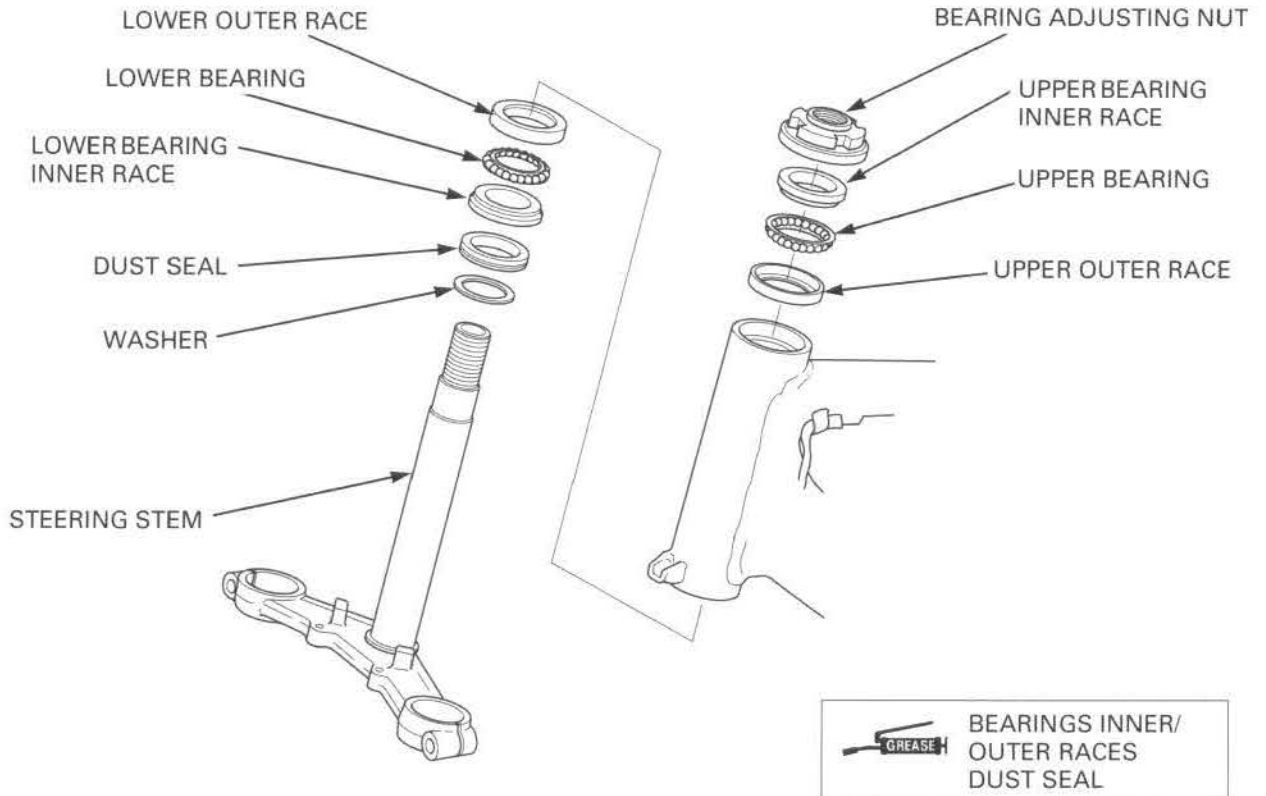

Apply grease to the lower races and lower bearing, then insert the lower bearing into the steering stem. Insert the steering stem into the steering head pipe.

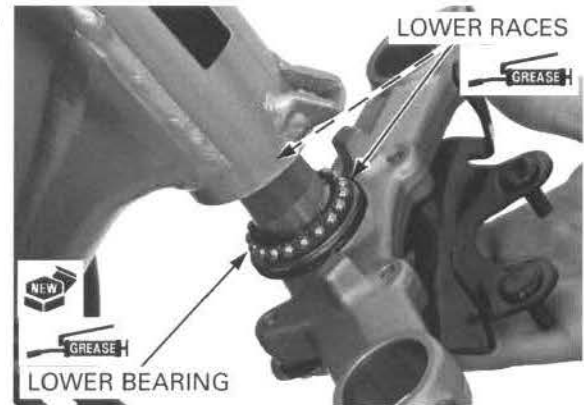

Apply grease to the upper races and upper bearing, then install the upper bearing and upper bearing inner race.



## FRONT WHEEL/BRAKE/SUSPENSION/STEERING

Hold the steering stem and tighten the stem bearing adjusting nut using the special tool to the initial torque.

**TOOLS:**

Lock nut wrench

07916-3710101 or  
07916-3710100  
(U.S.A. only)

**TORQUE:** 25 N·m (2.5 kgf·m, 18 lbf·ft)



Move the steering stem to the right and left, lock-to-lock, five times to seat the bearings.

Make sure that the steering stem moves smoothly, without play or binding; then loosen the bearing adjusting nut.



Retighten the bearing adjusting nut to the specified torque.

**TOOLS:**

Lock nut wrench

07916-3710101 or  
07916-3710100  
(U.S.A. only)

**TORQUE:** 2.5 N·m (0.25 kgf·m, 1.8 lbf·ft)



Install the top bridge to the steering head and temporarily install the fork legs. Install the washer and stem lock nut. Tighten the steering stem lock nut to the specified torque.

**TORQUE:** 74 N·m (7.5 kgf·m, 54 lbf·ft)

Recheck that the steering stem moves smoothly without play or binding.

Install the following:

- Fork legs (page 12-25)
- Front fender (page 2-5)
- Front wheel (page 12-13)
- Handlebar (page 12-7)

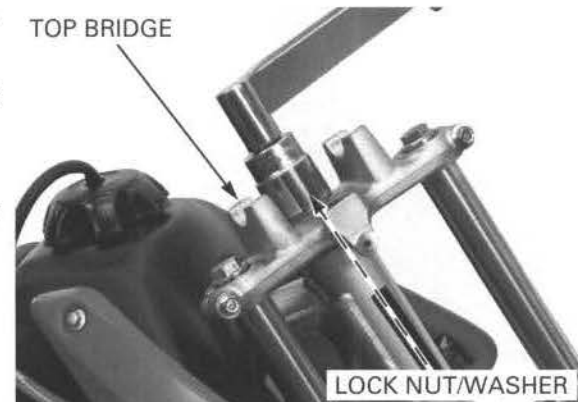



# 13. REAR WHEEL/BRAKE/SUSPENSION

---

COMPONENT LOCATION .....	13-2	BRAKE PEDAL .....	13-15
SERVICE INFORMATION .....	13-3	SHOCK ABSORBER.....	13-18
TROUBLESHOOTING .....	13-5	SHOCK LINKAGE .....	13-19
REAR WHEEL .....	13-6	SWINGARM.....	13-22
REAR BRAKE.....	13-12		

COMPONENT LOCATION

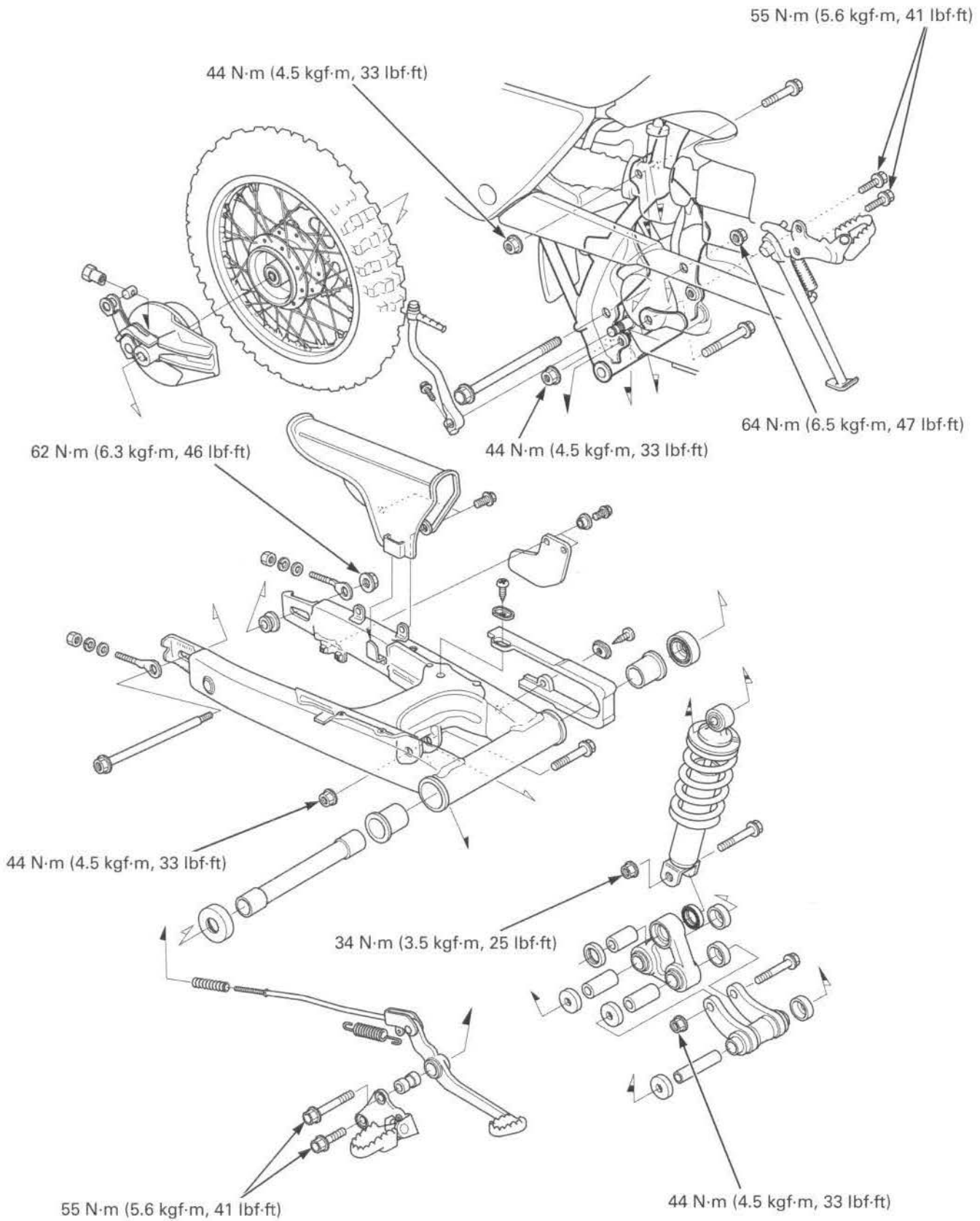

# SERVICE INFORMATION

## GENERAL

### ⚠ CAUTION

Frequent inhalation of brake shoe dust, regardless of material composition could be hazardous to your health.

- Avoid breathing dust particles.
- Never use an air hose or brush to clean brake assemblies. Use an OSHA-approved vacuum cleaner.
- Riding on damaged rims impairs safe operation of the motorcycle.
- Raise the rear wheel off the ground by supporting the frame securely when servicing. A box or work stand is required to support the motorcycle.
- A contaminated brake drum or shoe reduces stopping power. Discard contaminated shoes and clean a contaminated drum with a high quality brake degreasing agent.
- Use only genuine Honda replacement bolts and nuts for all suspension linkage and swingarm pivot mounting points; ordinary bolts lack adequate strength for these application. Also take note of the installation direction of these bolts since they must be installed correctly.
- Refer to page 3-17 for drive chain information.

## SPECIFICATIONS

Unit: mm (in)







ITEM			STANDARD	SERVICE LIMIT	
Rear wheel	Cold tire pressure		100 kPa (1.00 kgf/cm <sup>2</sup> , 14 psi)	-	
	Rearwheel rim runout	Radial	-	2.0 (0.08)	
		Axial	-	2.0 (0.08)	
	Wheel hub-to-rim distance		11.0 ± 1.0	-	
	Rear axle runout		-	0.20 (0.008)	
Drive chain	Slack		25 – 35 (1.0 – 1.4)	0.2 (0.01)	
	Size/link	CRF100F	RK	RK428FDZ-118RJ	-
		CRF80F	RK	RK420MSZ1-110RJ	-
			DID	DID420MBK1-110RB	-
Brake drum I.D.		95.0 (3.74)	96.0 (3.78)		
Shock absorber	Spring free length	CRF100F	123.5 (4.86)	121.0 (4.76)	
		CRF80F	137.0 (5.39)	134.3 (5.29)	
Shock linkage	Bushing I.D.		18.000 – 18.052 (0.7087 – 0.7107)	18.25 (0.719)	
	Collar O.D.		17.941 – 17.968 (0.7063 – 0.7074)	17.91 (0.705)	
Swingarm	Bushing I.D.		14.990 – 15.030 (0.5902 – 0.5917)	15.20 (0.598)	
	Collar O.D.		14.966 – 14.984 (0.5892 – 0.5899)	14.94 (0.588)	
Brake pedal	Pedal hole I.D.		17.300 – 17.327 (0.6811 – 0.6822)	15.20 (0.598)	
	Collar O.D.		17.294 – 17.298 (0.6809 – 0.6810)	17.27 (0.680)	

## TORQUE VALUES

Rear axle nut	62 N·m (6.3 kgf·m, 46 lbf·ft)	U-nut
Driven sprocket nut	32 N·m (3.3 kgf·m, 24 lbf·ft)	U-nut
Swingarm pivot nut	64 N·m (6.5 kgf·m, 47 lbf·ft)	U-nut
Shock absorber upper mounting nut	44 N·m (4.5 kgf·m, 33 lbf·ft)	U-nut
Shock absorber lower mounting nut	34 N·m (3.5 kgf·m, 25 lbf·ft)	U-nut
Shock absorber arm nut	44 N·m (4.5 kgf·m, 33 lbf·ft)	U-nut
Shock absorber connecting rod nut	44 N·m (4.5 kgf·m, 33 lbf·ft)	U-nut
Rear brake arm nut	10 N·m (1.0 kgf·m, 7 lbf·ft)	U-nut
Spoke	3 N·m (0.3 kgf·m, 2 lbf·ft)	
Foot peg mounting bolt	55 N·m (5.6 kgf·m, 41 lbf·ft)	

# REAR WHEEL/BRAKE/SUSPENSION

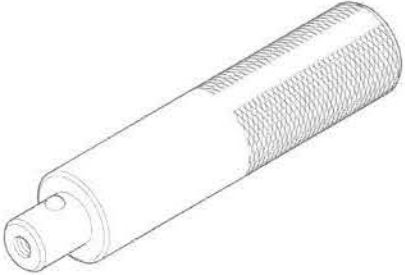
## TOOLS

<p>Spoke wrench, 4.5 x 5.1 mm 07701-0020200</p>  <p>or equivalent commercially available in U.S.A.</p>	<p>Bearing remover head, 12 mm 07746-0050300</p> 	<p>Bearing remover shaft 07746-0050100</p> 
<p>Attachment, 32 x 35 mm 07746-0010100</p> 	<p>Attachment, 37 x 40 mm 07746-0010200</p> 	<p>Driver 07749-0010000</p> 
<p>Pilot, 12 mm 07746-0040200</p> 		

## TROUBLESHOOTING

### Rear wheel wobbles

- Bent rim
- Worn or damaged rear wheel bearings
- Faulty rear tire
- Loose or broken spokes
- Worn or damaged swingarm bearings or pivot bushings
- Bent frame or swingarm
- Axle fastener not tightened properly
- Unbalanced tire and wheel
- Tire pressure too low

### Wheel hard to turn

- Brake drag
- Faulty wheel bearings
- Bent axle
- Drive chain too tight (See page 3-17)

### Soft suspension

- Weak shock absorber springs
- Oil leakage from damper unit
- Tire pressure too low

### Stiff suspension

- Bent shock absorber damper rod
- Damaged suspension or swingarm pivot bearings
- Damaged swingarm pivot bushings
- Bent swingarm pivot or frame
- Tire pressure too high

### Steers to one side or does not track straight

- Drive chain adjusters not adjusted equally
- Bent axle
- Bent frame

### Rear suspension noise

- Loose suspension fasteners
- Worn or damaged suspension pivot bearings
- Faulty shock absorber

REAR WHEEL

REMOVAL

Support the motorcycle securely and raise the rear wheel off the ground by placing a work stand under the engine.

Remove the rear brake adjusting nut and disconnect the rear brake rod from the brake arm, and remove the joint pin and spring.

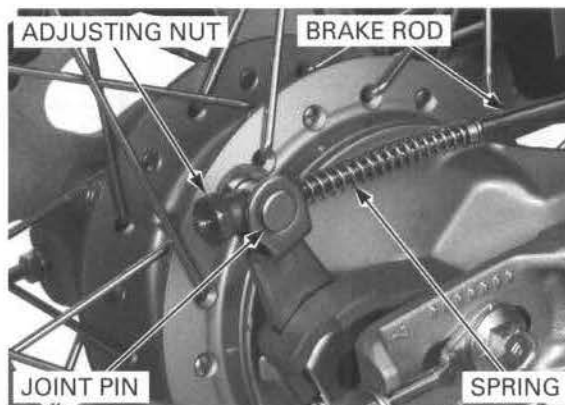

Loosen the left and right drive chain adjust nuts. Remove the rear axle nut and drive chain adjuster. Push the rear wheel forward. Remove the drive chain from the driven sprocket.

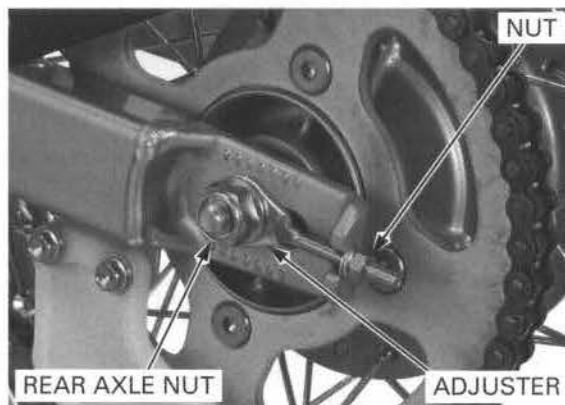

Remove the rear axle and drive chain adjuster from the right side and remove the rear wheel.

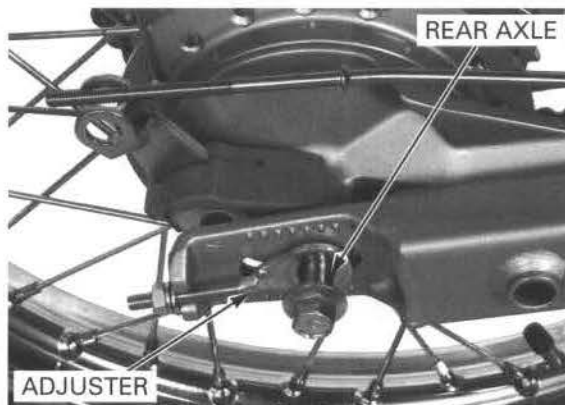

Remove the brake panel assembly from the right wheel hub.

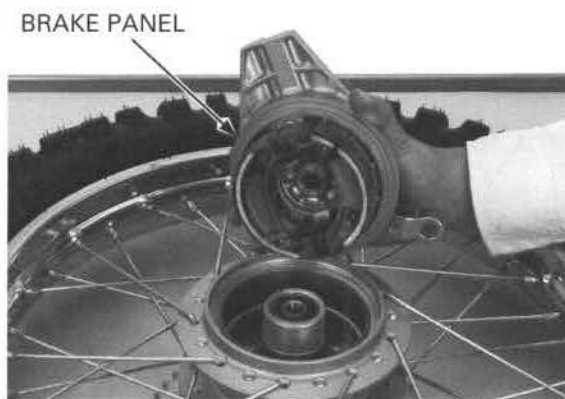

Remove the left side collar and dust seal from the left wheel hub.

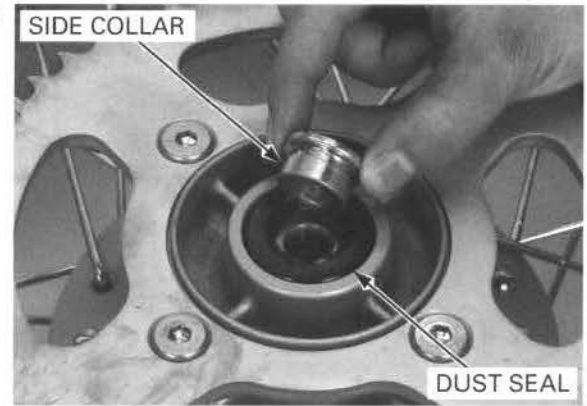

**INSPECTION**

**Axle**

Set the axle on V-blocks and measure the runout. The actual runout is 1/2 of the total indicator reading.

**SERVICE LIMIT: 0.2 mm (0.01 in)**

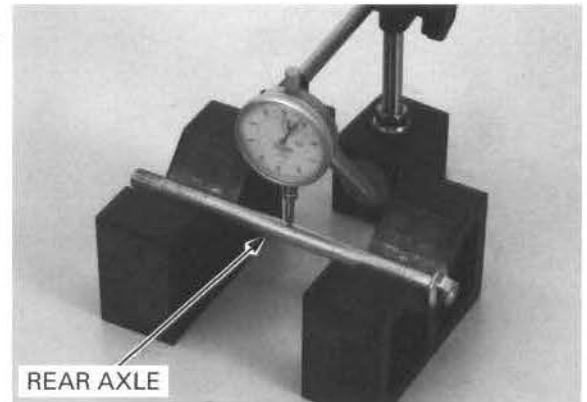

**Wheel bearing**

Turn the inner race of each bearing with your finger. Bearings should turn smoothly and quietly. Also check that the bearing outer race fits tightly in the hub.

*Replace the wheel bearings in pairs.*

Remove and discard the bearings if the races do not turn smoothly and quietly, or if they fit loosely in the hub.

Install the new bearings into the hub using the special tools (page 13-9).

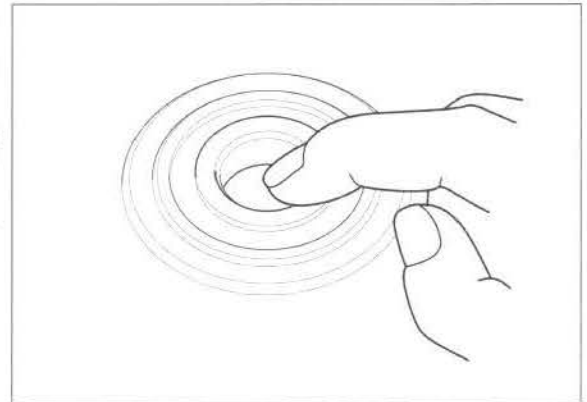

**Wheel rim runout**

Check the rim runout by placing the wheel in a turning stand.

Turn the wheel slowly and measure the runout using a dial indicator.

The actual runout is 1/2 of the total indicator reading.

**SERVICE LIMITS:**

**Radial: 2.0 mm (0.08 in)**

**Axial: 2.0 mm (0.08 in)**

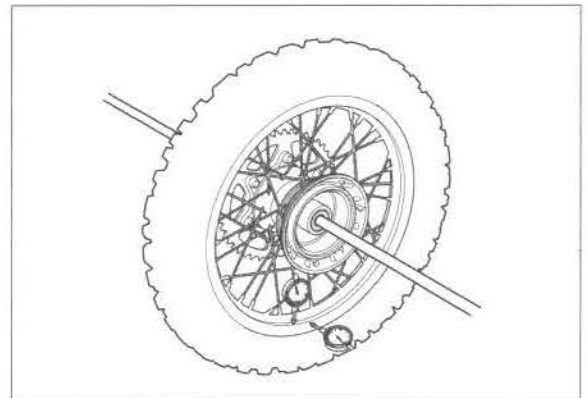

## REAR WHEEL/BRAKE/SUSPENSION

### Driven sprocket

Check the condition of the final driven sprocket teeth.

Replace the sprocket if it is worn or damaged.

- If the final driven sprocket requires replacement, inspect the drive chain and drive sprocket.
- Never install a new drive chain on a worn sprocket or a worn chain on new sprockets. Both chain and sprocket must be in good condition or the replacement chain or sprocket will wear rapidly.

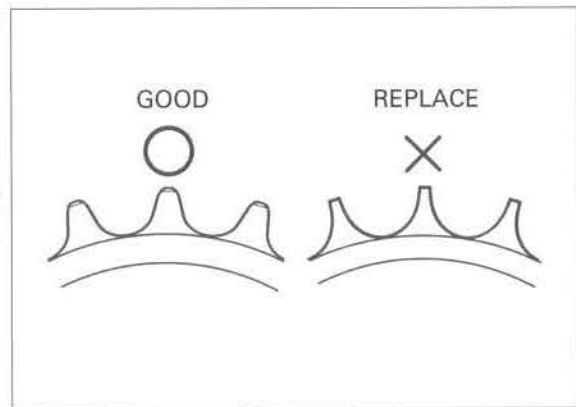

### DISASSEMBLY

Remove the driven sprocket nuts, bolts and driven sprocket.

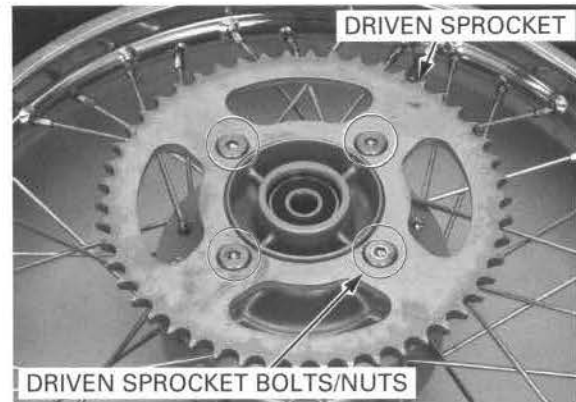

### Wheel bearing removal

Install the bearing remover head into the bearing.

From the opposite side, install the bearing remover shaft and drive the bearing out of the wheel hub.

Remove the distance collar and drive out the other bearing.

#### TOOLS:

Bearing remover head, 12 mm 07746-0050300  
Bearing remover shaft 07746-0050100





ASSEMBLY

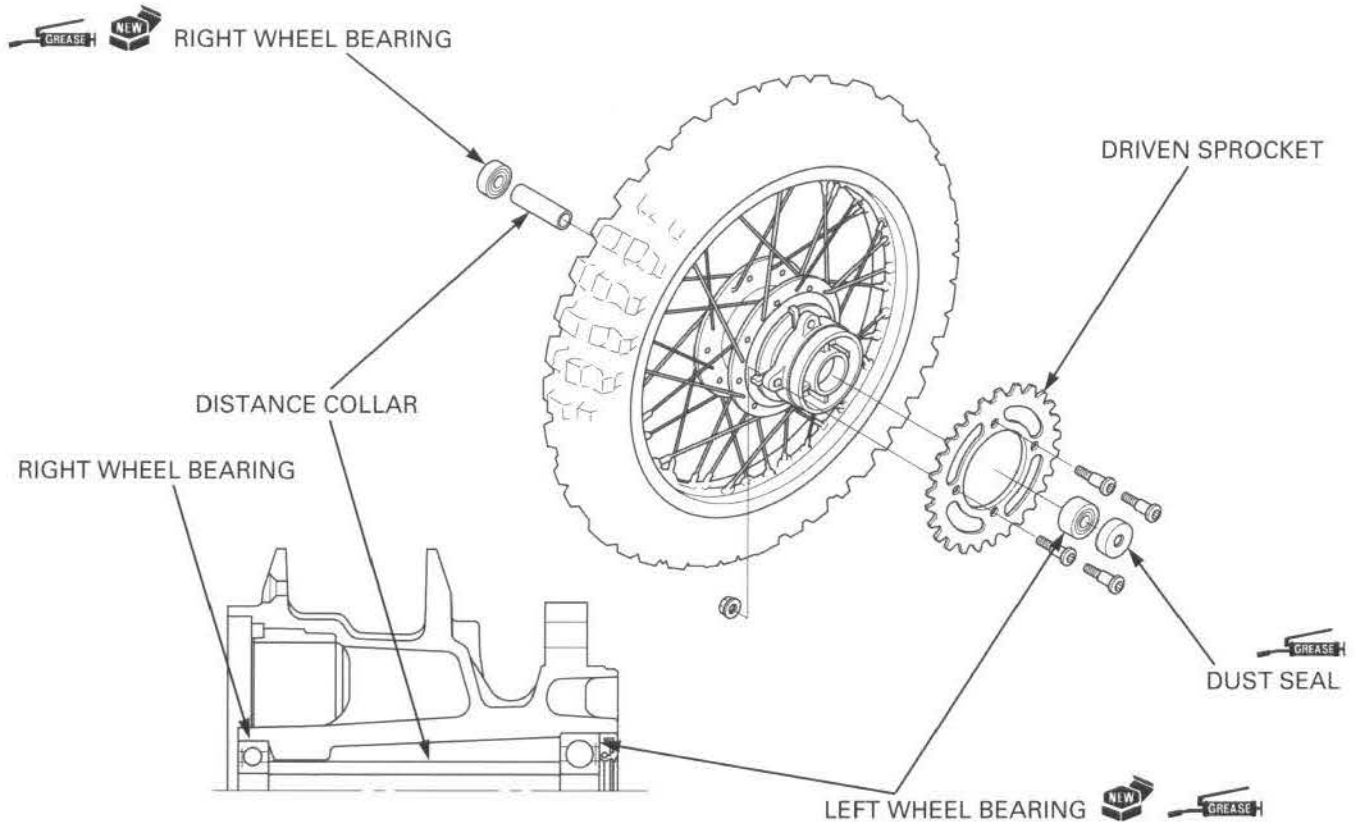

**Wheel bearing installation**

Pack the new bearing cavities with grease.

*Replace the wheel bearings in pairs. Do not reuse old bearings.*

Drive in a new right wheel bearing squarely with its sealed side facing out.

**TOOLS:**

- Driver**
- Attachment, 32 x 35 mm**
- Pilot, 12 mm**

- 07749-0010000
- 07746-0010100
- 07746-0040200

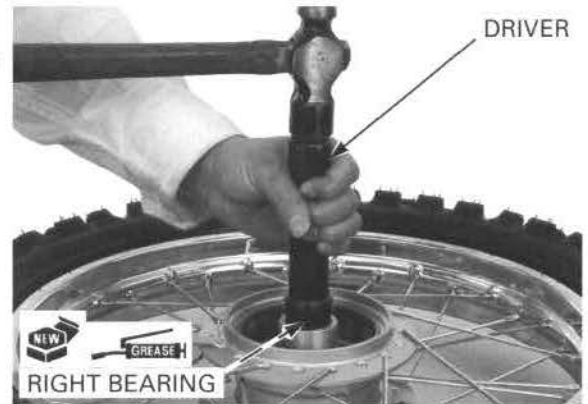

Install the distance collar, then drive in the left wheel bearing with its sealed side facing out.

**TOOLS:**

- Driver**
- Attachment, 37 x 40 mm**
- Pilot, 12 mm**

- 07749-0010000
- 07746-0010200
- 07746-0040200

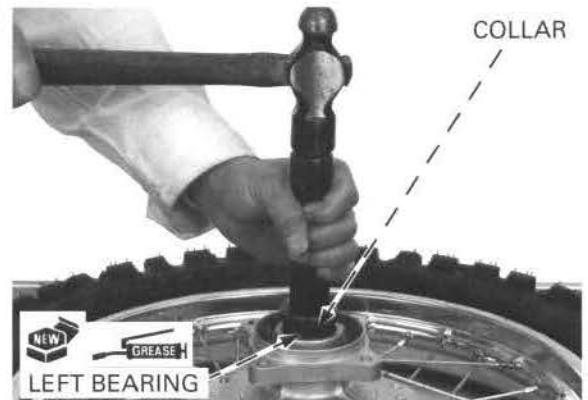

## REAR WHEEL/BRAKE/SUSPENSION

*Wheel center adjustment is necessary when new spokes are installed.*

### Wheel center adjustment

Place the rim on the work bench.

Place the hub with the left side down and begin lacing with new spokes.

Adjust the hub position so the distance from the hub right end surface to the side of the rim is  $11.0 \pm 1.0$  mm ( $0.43 \pm 0.039$  in) as shown.

Tighten the spokes in 2 or 3 progressive steps to the specified torque.

### TOOL:

Spoke wrench, 4.5 x 5.1 mm      07701-0020200 or equivalent commercially available in U.S.A.

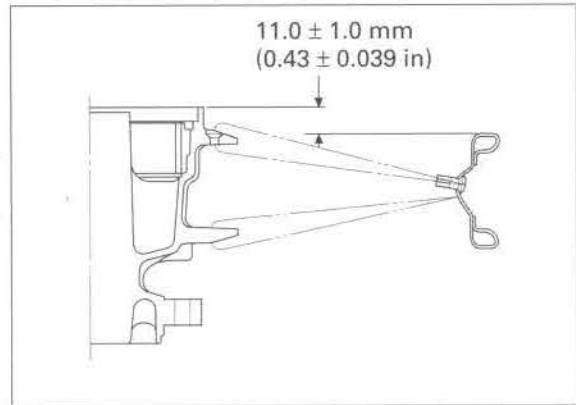

**TORQUE: 3 N·m (0.3 kgf·m, 2 lbf·ft)**

Check the wheel rim runout (page 13-7).

Install the driven sprocket, bolts and nuts.

Tighten the nuts to the specified torque while holding the bolts.

**TORQUE: 32 N·m (3.3 kgf·m, 24 lbf·ft)**

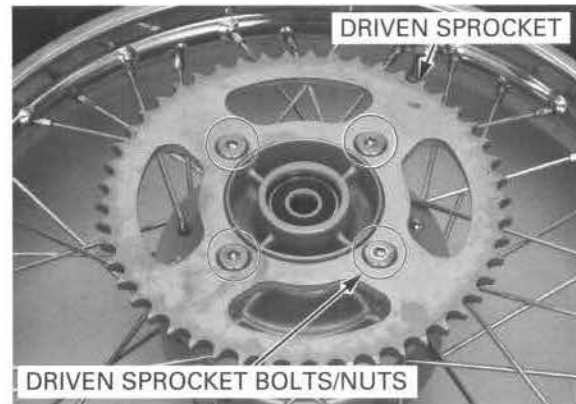

## INSTALLATION

Apply grease to the dust seal lips, then install it into the left wheel hub.

Install the left side collar into the left wheel hub.

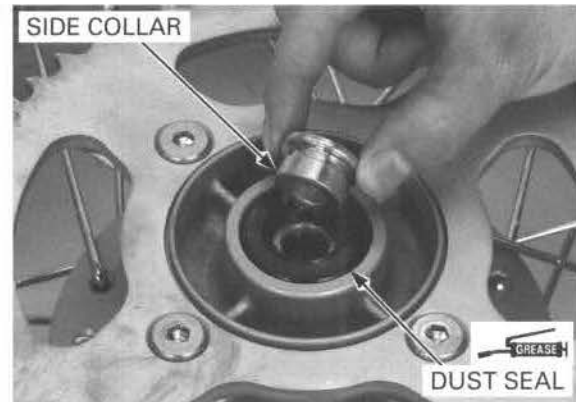

Install the brake panel assembly into the right wheel hub.

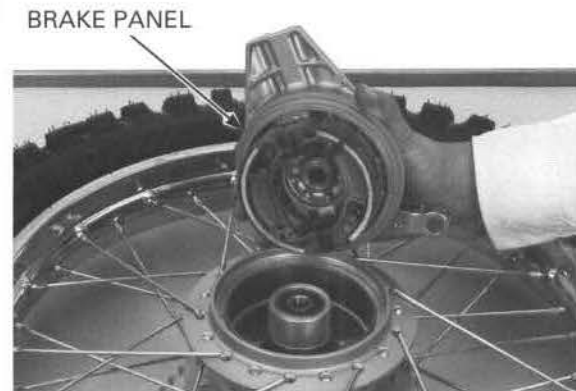

Place the rear wheel into the swingarm by aligning the brake panel groove with the swingarm boss.

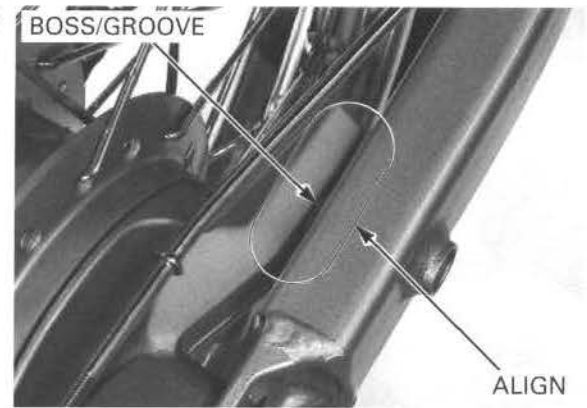

Install the drive chain over the driven sprocket.  
Apply a thin layer of grease to the axle surface.  
Install the rear axle with the right drive chain adjuster from the right side.

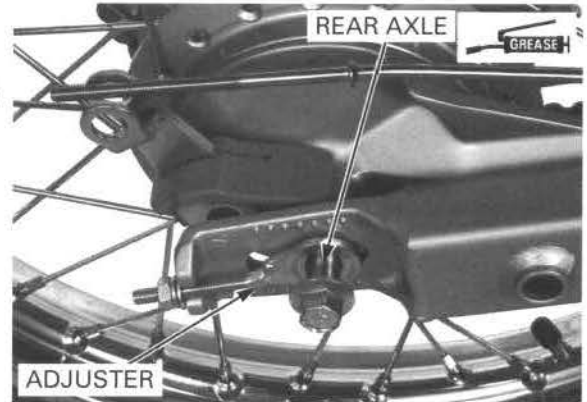

Install the left drive chain adjuster and rear axle nut.  
Adjust the drive chain slack (page 3-17).  
Tighten the axle nut to the specified torque.  
**TORQUE: 62 N·m (6.3 kgf·m, 46 lbf·ft)**

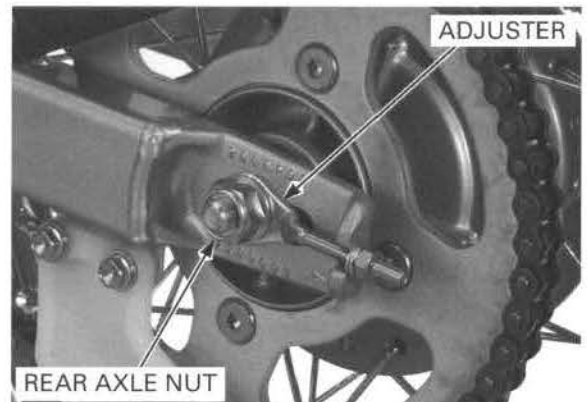

Install the spring onto the brake rod.  
Connect the brake rod to the brake arm with the joint pin.  
Install the brake adjusting nut loosely.  
Adjust the rear brake pedal free play (page 3-21).

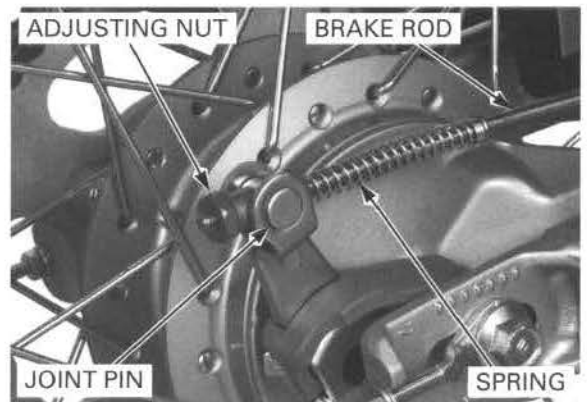

## REAR BRAKE

### BRAKE PANEL REMOVAL

Remove the rear wheel and then remove the brake panel (page 13-6).

### INSPECTION

Measure the rear brake drum I.D.

**SERVICE LIMIT: 96.0 mm (3.78 in)**

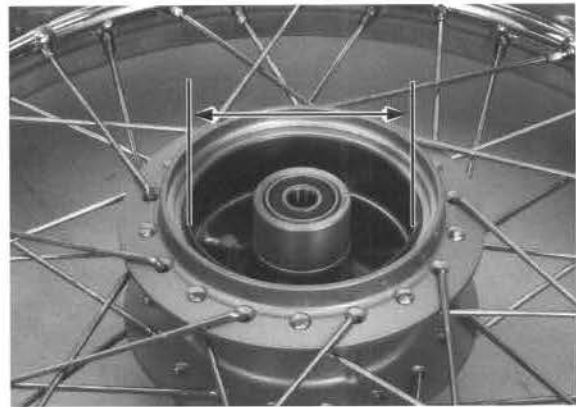

Check the brake shoe springs for fatigue or damage and check the brake cam for wear or damage.

Measure the brake lining thickness.

**SERVICE LIMIT: 2.0 mm (0.08 in)**



### BRAKE PANEL DISASSEMBLY

*Mark the side of the brake shoes to indicate their original position, before removing them.*

Pull the brake shoes apart and remove them from the brake panel.

Remove the springs from the brake shoes.

BRAKE SHOES



Remove the brake arm cover.

Remove the nut, bolt and brake arm.

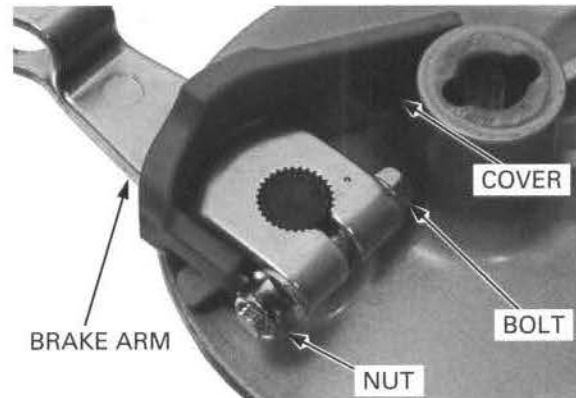

Remove the indicator plate.

INDICATOR PLATE

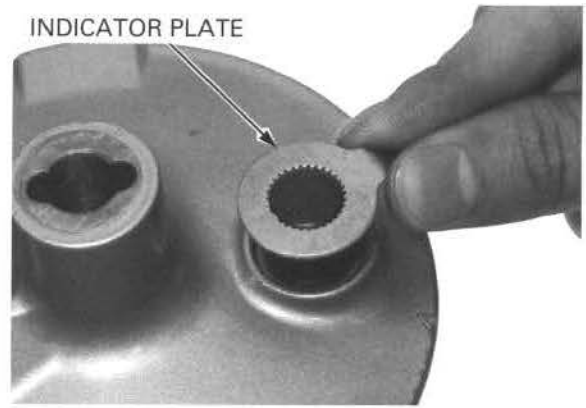

Remove the brake cam and dust seal.

BRAKE CAM



DUST SEAL

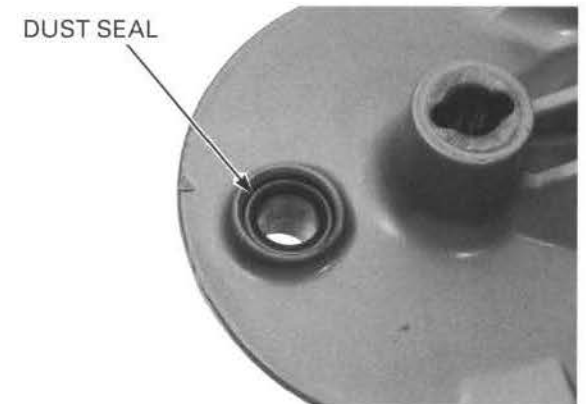

BRAKE PANEL ASSEMBLY

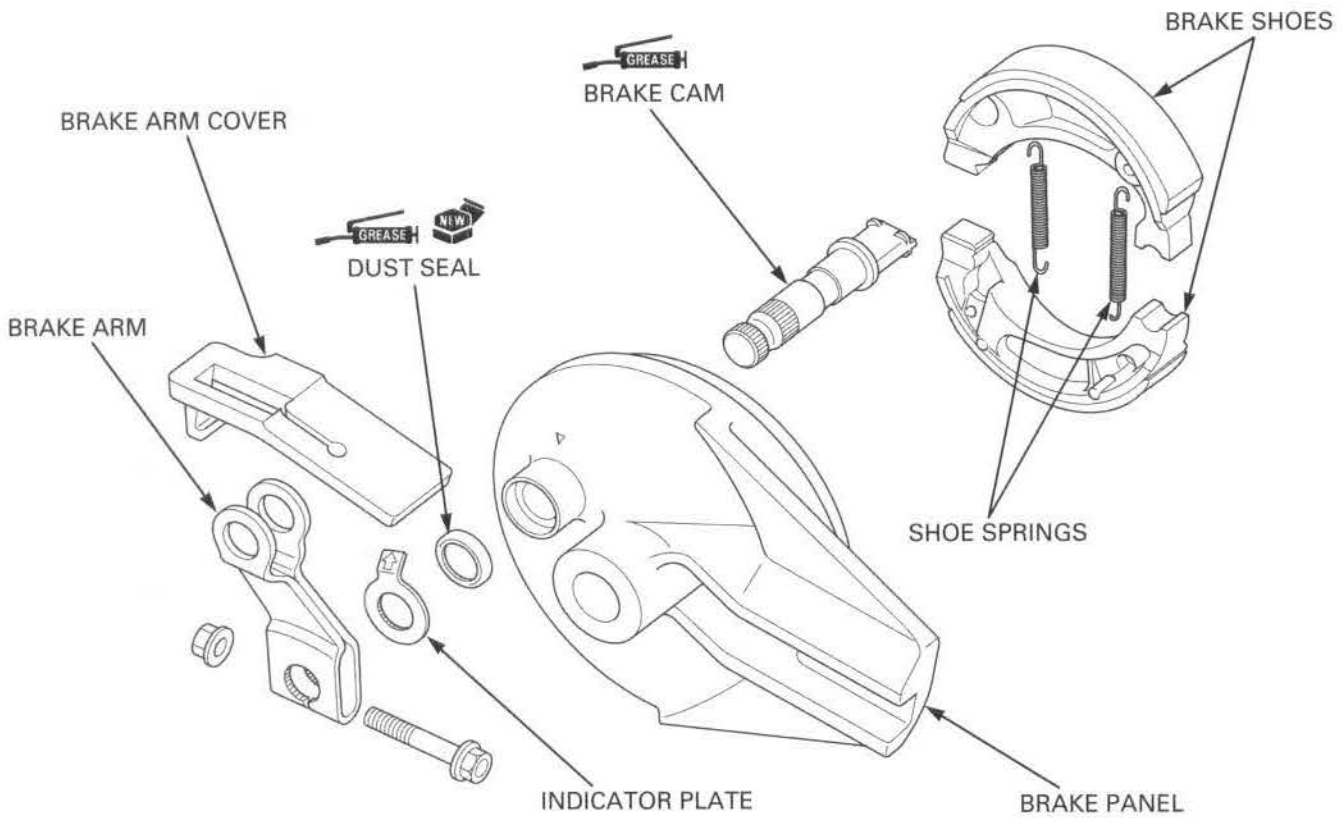

Apply grease to the new dust seal lips.

Install a dust seal with the flat surface facing out until they are seated.

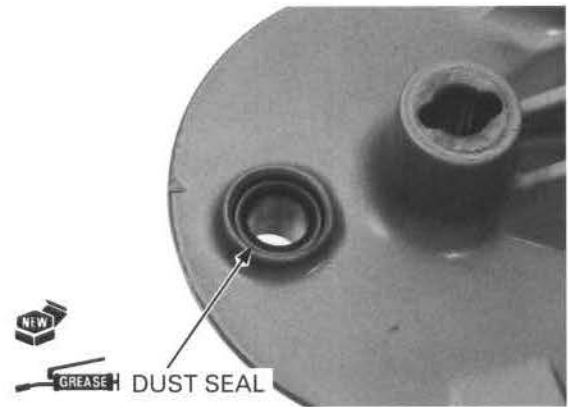

Apply grease to the brake cam and brake shoe anchor pin.

Install the brake cam into the brake panel.

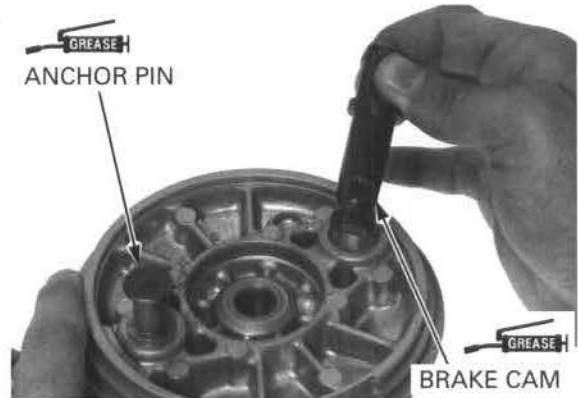

Install the wear indicator plate onto the brake cam by aligning its wide tooth with the wide groove in the brake cam.

INDICATOR PLATE

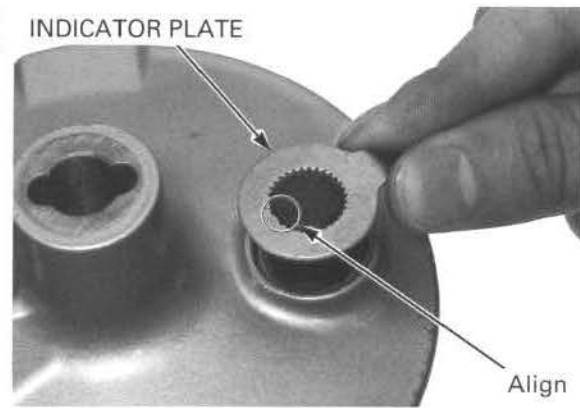

Install the brake arm by aligning the punch marks on the brake arm and brake cam.

Install the brake arm pinch bolt and nut, then tighten the nut to the specified torque.

**TORQUE: 10 N·m (1.0 kgf·m, 7 lbf·ft)**

Install the brake arm cover.

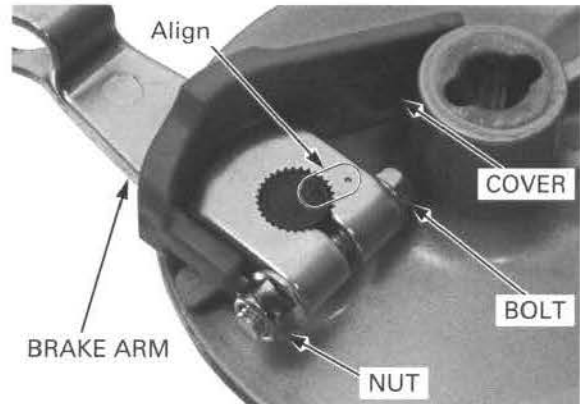

**INSTALLATION**

Install the brake shoes and springs onto the brake panel as shown.

Install the rear wheel (page 13-10).

BRAKE SHOES

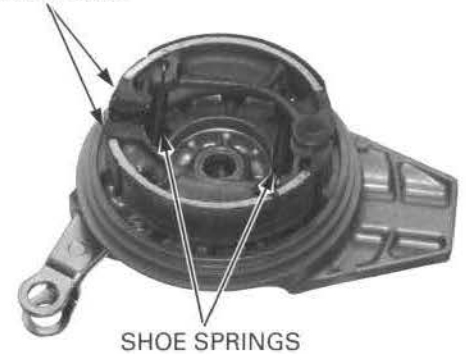

**BRAKE PEDAL**

**REMOVAL/DISASSEMBLY**

Remove the brake pedal adjusting nut.

Push the brake pedal down and remove the brake rod from the brake arm.

Remove the spring and joint pin.

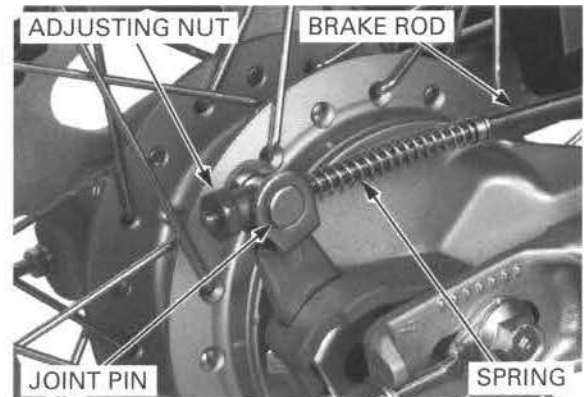

## REAR WHEEL/BRAKE/SUSPENSION

Remove the brake pedal return spring.

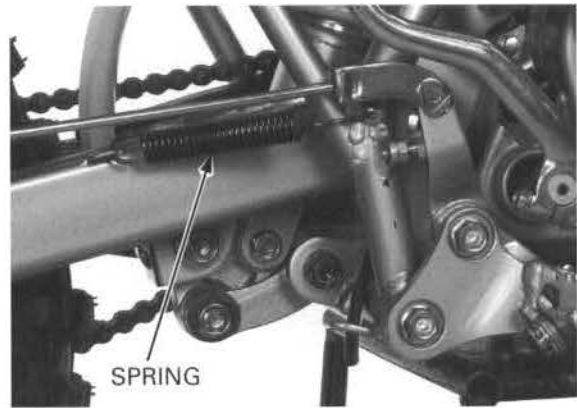

Remove the two bolts and right foot peg and brake pedal.

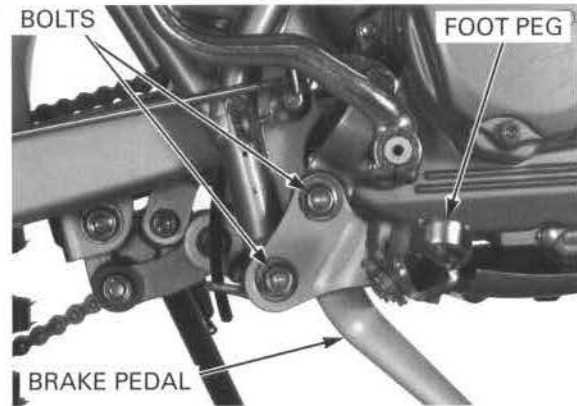

Remove the pivot collar.

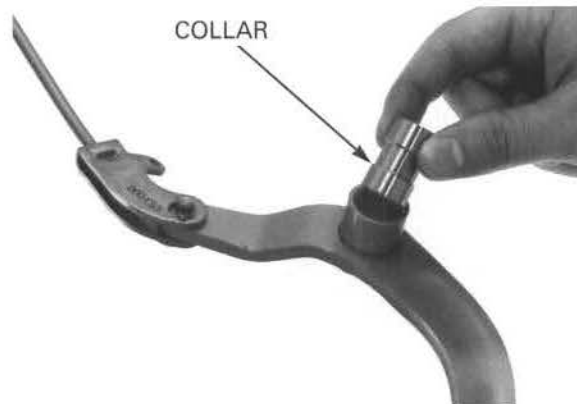

Remove the split pin and joint pin.

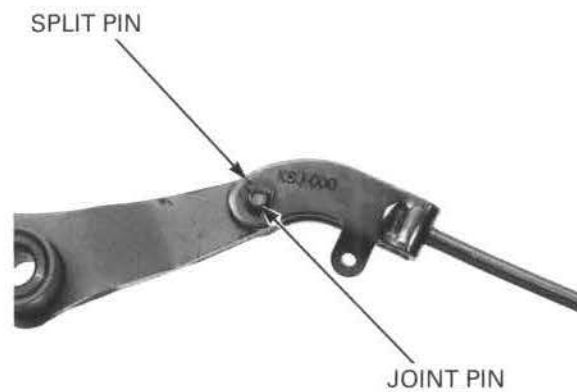



**ASSEMBLY/INSTALLATION**

Install the joint pin and new split pin.

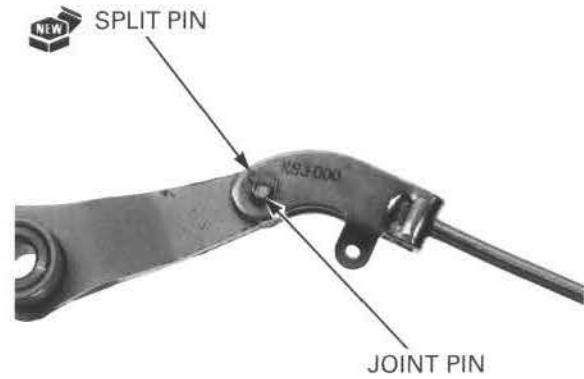

Apply grease to the pivot collar sliding surface then install the pivot collar into the brake pedal.

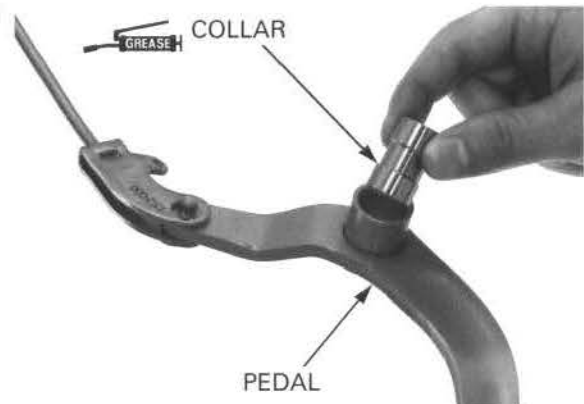

Install the brake pedal and right foot peg.  
Tighten the two bolts to the specified torque.  
**TORQUE: 55 N·m (5.6 kgf·m, 41 lbf·ft)**

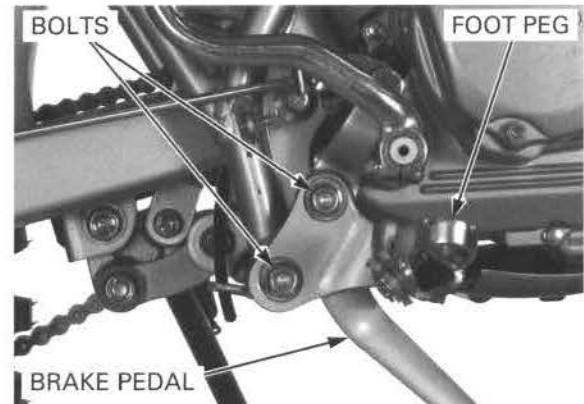

Install the return spring to the swingarm.

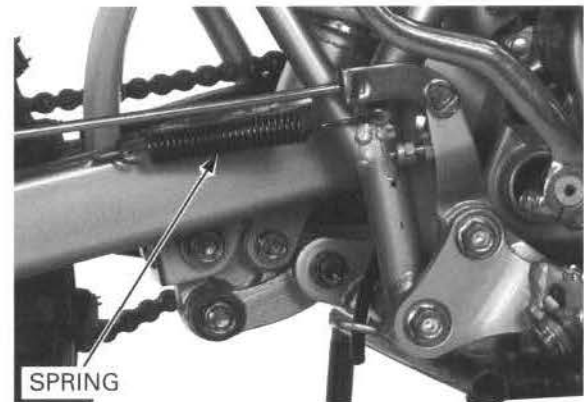

## REAR WHEEL/BRAKE/SUSPENSION

Install the spring onto the brake rod.

Install the joint pin onto the brake arm.

Push down the brake pedal and install the brake rod into the joint pin.

Install the brake adjusting nut and adjust the brake pedal free play (page 3-21).

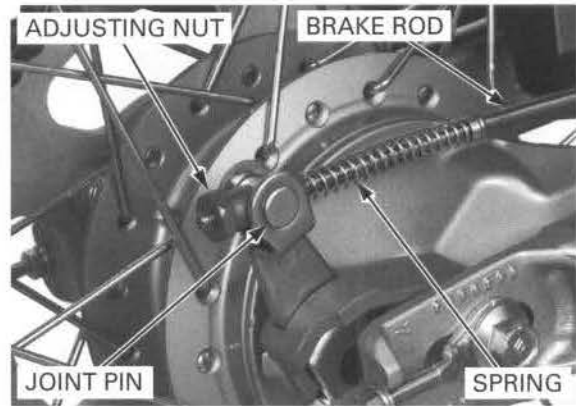

## SHOCK ABSORBER

### REMOVAL

Support the motorcycle securely and raise the rear wheel off the ground by placing a work stand under the engine.

Remove the shock absorber lower and connecting rod (swingarm side) mounting bolts/nuts.

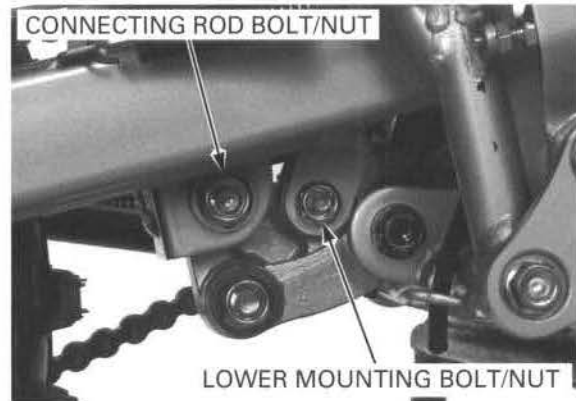

Remove the upper mounting bolt/nut, then remove the shock absorber from the frame.

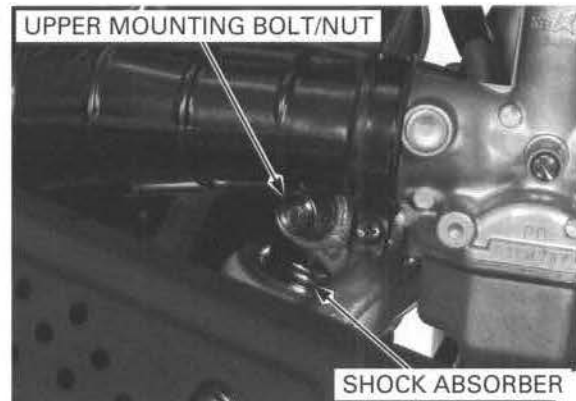

### INSPECTION

Visually inspect the shock absorber for damage.

Check the:

- Damper rod for bend or damage.
- Damper unit for deformation or oil leaks.
- Bump rubber for wear or damage.

Check for smooth damper operation.

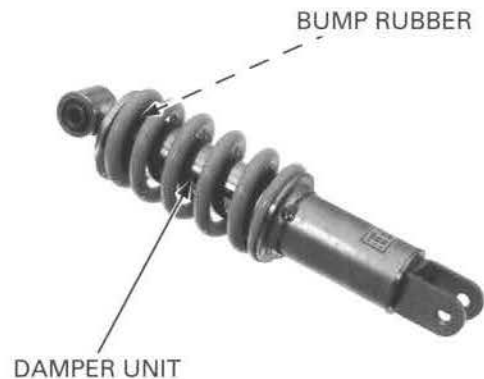

Check the upper bushing for wear or damage.  
 Inspect all the other parts for wear or damage.  
 If necessary, replace the shock absorber as an assembly.

BUSHING



**INSTALLATION**

Install the shock absorber into the frame.  
 Install the upper and lower mounting bolts and nuts.  
 Install the connecting rod (swing arm side) bolts and nuts.  
 Tighten the upper mounting nut to the specified torque.

**TORQUE: 44 N·m (4.5 kgf·m, 33 lbf·ft)**

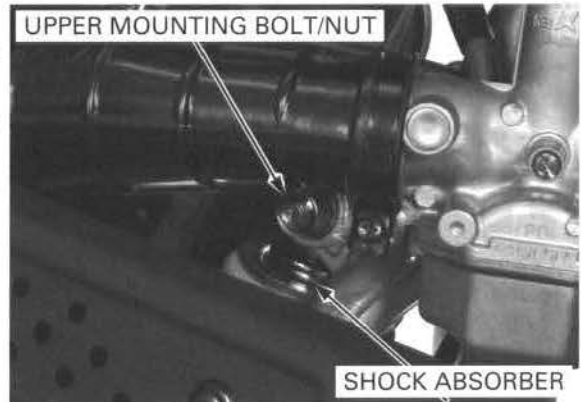

Tighten the lower mounting and connecting rod (swing arm side) bolts/nuts to the specified torque.

**TORQUE:**

- Shock absorber lower mounting nut:  
     **34 N·m (3.5 kgf·m, 25 lbf·ft)**
- Shock absorber connecting rod nut:  
     **44 N·m (4.5 kgf·m, 33 lbf·ft)**

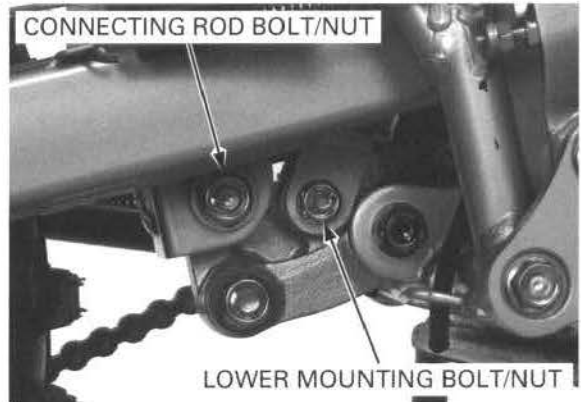

**SHOCK LINKAGE**

**REMOVAL**

Support the motorcycle securely and raise the rear wheel off the ground by placing a work stand under the engine.  
 Remove the two bolts and left foot peg.

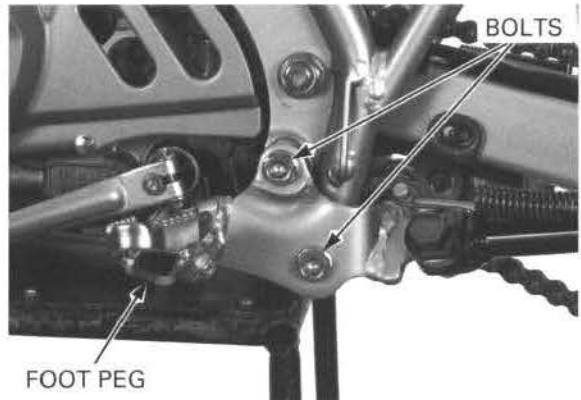

## REAR WHEEL/BRAKE/SUSPENSION

Remove the bolt and lower chain slider.

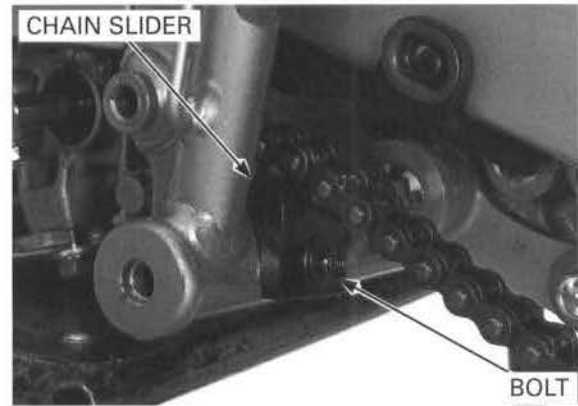

Remove the following:

- Shock absorber lower mounting bolt/nut
- Shock absorber connecting rod nuts/bolts
- Shock absorber arm bolt/nut

Remove the shock absorber connecting rod and shock absorber arm.

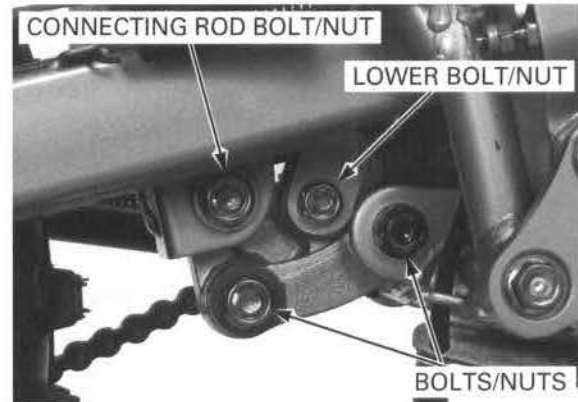

### INSPECTION

Remove the dust seals and pivot collars.

Check the dust seals and collars and bushing for wear, damage or deterioration.

Check the shock absorber arm and shock absorber connecting rod for cracks or damage.

Measure the bushing I.D.

**SERVICE LIMIT: 18.25 mm (0.719in)**

Measure the collar O.D.

**SERVICE LIMIT: 17.91 mm (0.705 in)**

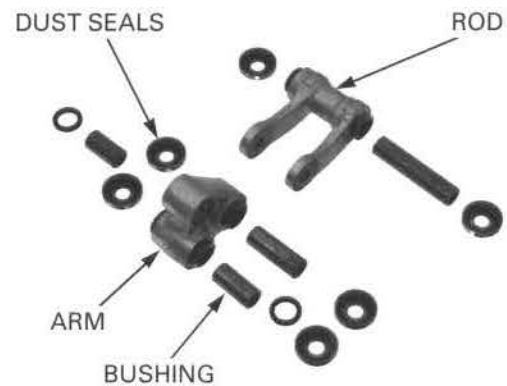

### ASSEMBLY

Apply molybdenum disulfide paste to each bushing rolling area and dust seal lips surface.



**INSTALLATION**

Install the shock absorber arm and shock absorber connecting rod.

Install the following:

- Shock absorber lower mounting bolt
- Shock absorber connecting rod bolts
- Shock absorber arm bolt

Tighten the each nuts to the specified torque as shown.

**TORQUE:**

- Shock absorber lower mounting nut:  
34 N·m (3.5 kgf·m, 25 lbf·ft)
- Shock absorber connecting rod nuts:  
44 N·m (4.5 kgf·m, 33 lbf·ft)
- Shock absorber arm nut:  
44 N·m (4.5 kgf·m, 33 lbf·ft)

Install the lower chain slider and tighten the bolt.

Install the left foot peg and tighten the two bolts to the specified torque.

**TORQUE: 55 N·m (5.6 kgf·m, 41 lbf·ft)**

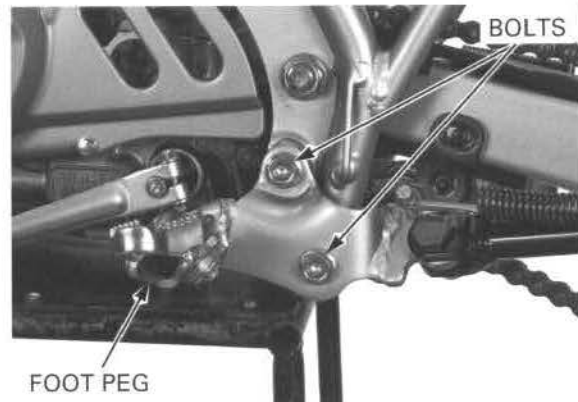
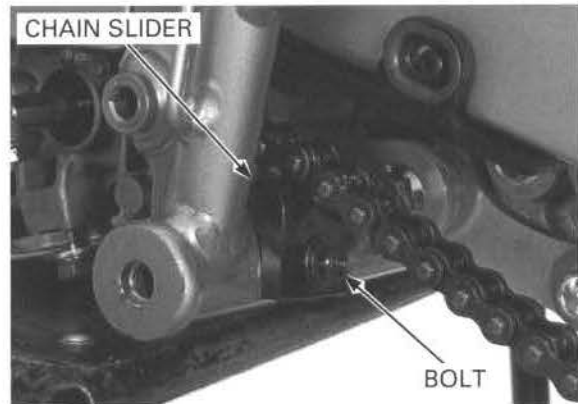
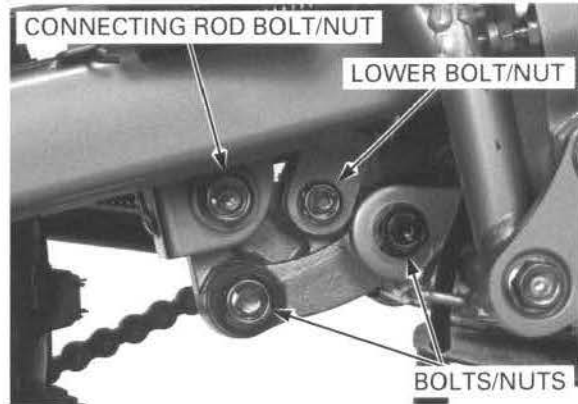
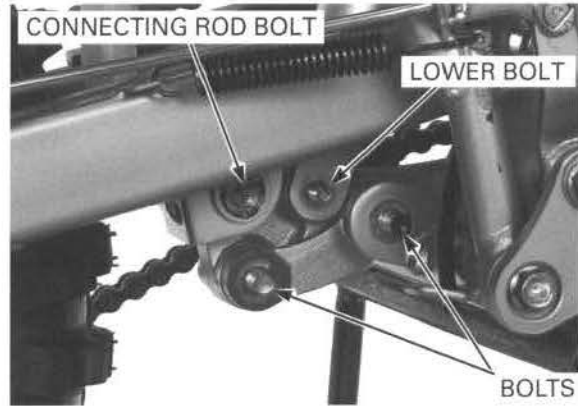

**SWINGARM**

**REMOVAL**

Remove the following:

- Rear wheel (page 13-6)
- Shock linkage (page 13-19)

Remove the return spring.

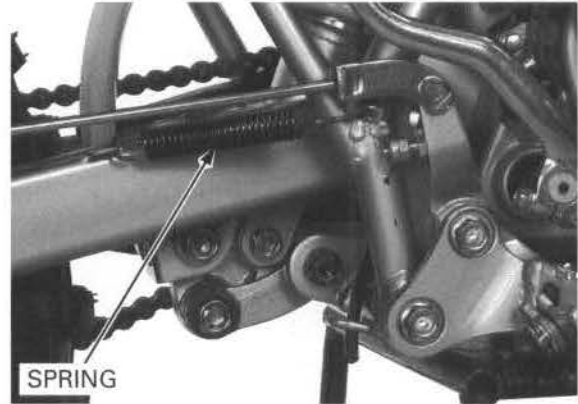

Remove the two bolts and drive chain case.

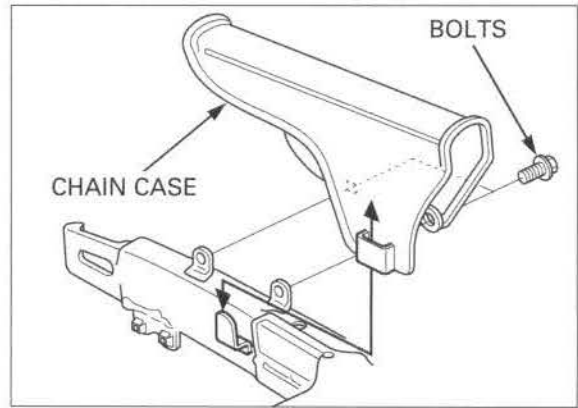

Remove the swingarm pivot nut.

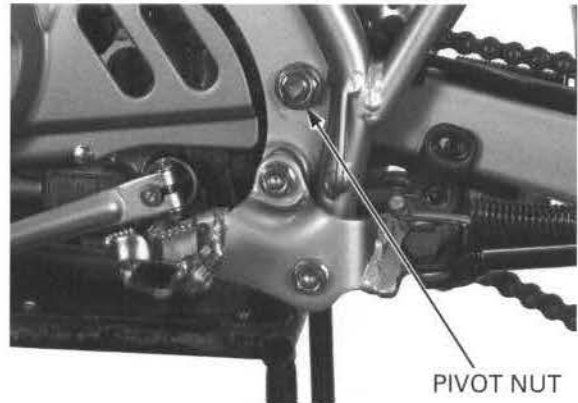

Remove the swingarm pivot bolt, then remove the swingarm from the frame.

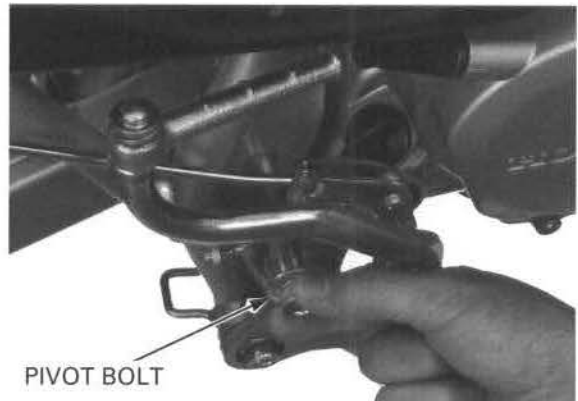

**DISASSEMBLY**

Remove the drive chain guard.

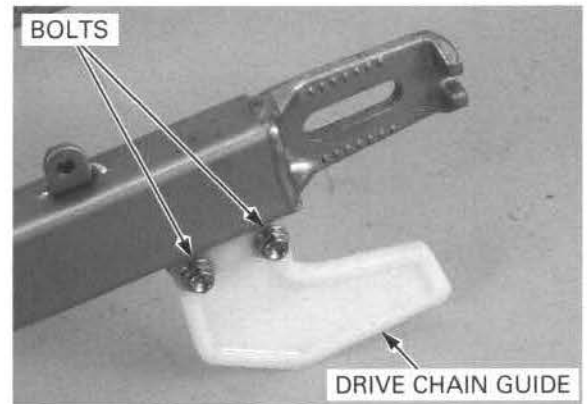

Remove the two screws and drive chain slider.

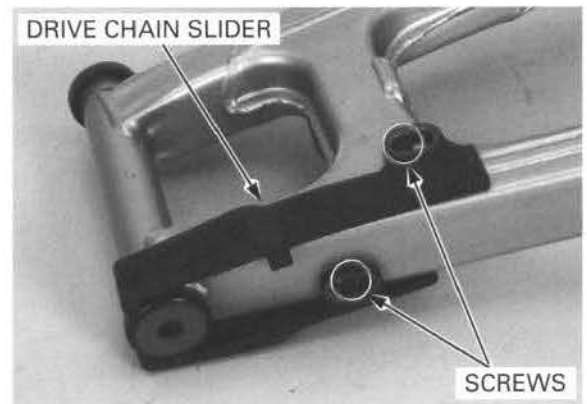

Remove the dust seals and pivot collar.

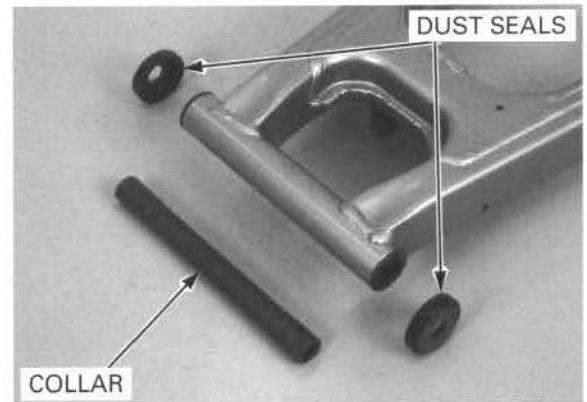

**INSPECTION**

Measure each bushing I.D. and the pivot collar O.D.

**SERVICE LIMITS:**

Bushing I.D.: 15.20 mm (0.598 in)

Pivot collar O.D.: 14.94 mm (0.588 in)

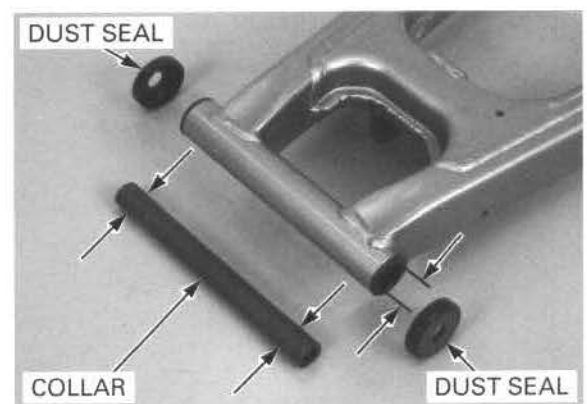

## REAR WHEEL/BRAKE/SUSPENSION

### BUSHING REPLACEMENT

Drive the bushings out of the swingarm.

Drive a new bushing into the swingarm using the special tools.

#### TOOLS:

Driver

07749-0010000

Attachment, 32 x 35 mm

07746-0010100

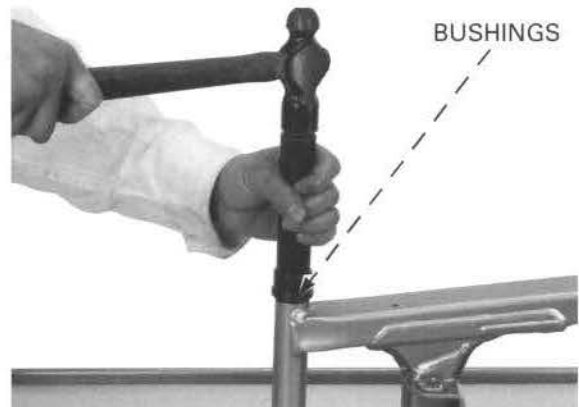

### ASSEMBLY

Apply grease to the bushings, pivot collar and new dust seal lips.

Install the pivot collar into the swingarm and install the dust seals.

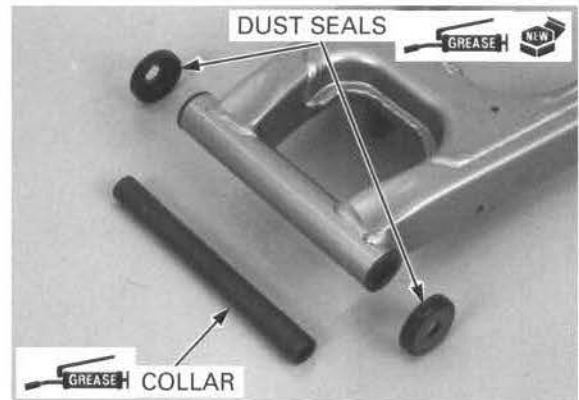

Install the drive chain slider and two screws.

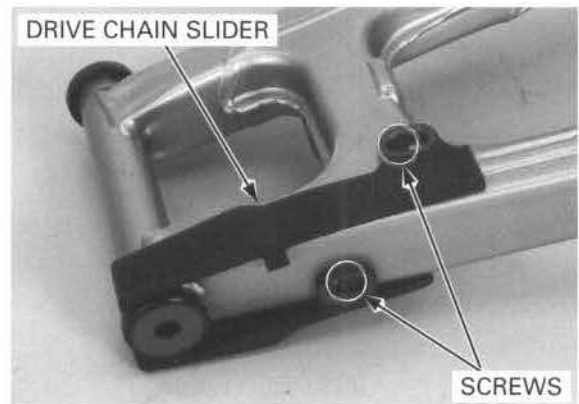

Install the drive chain guard.

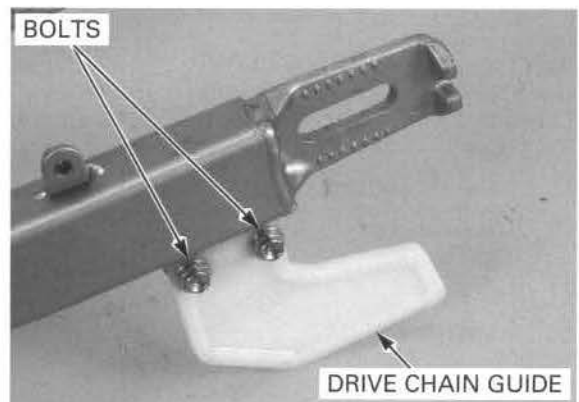



**INSTALLATION**

Apply a thin layer of grease to the swingarm pivot bolt sliding surface.

Install the swingarm and pivot bolt.

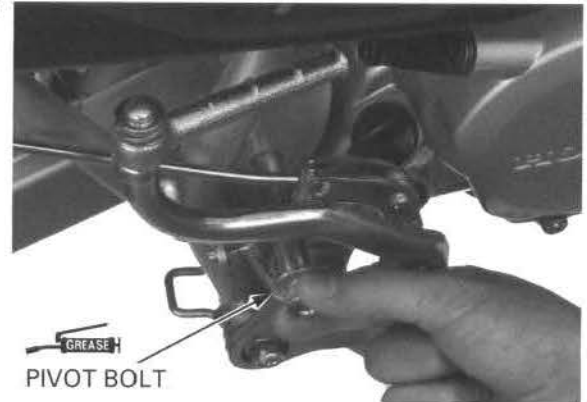

Install and tighten the swingarm pivot nut to the specified torque.

**TORQUE: 64 N·m (6.5 kgf·m, 47 lbf·ft)**

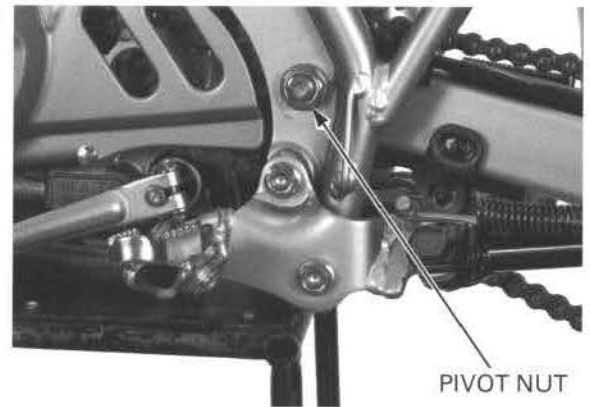

Install the drive chain case and bolts.

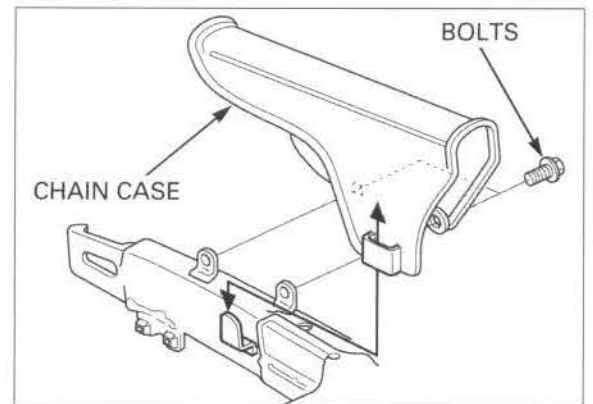

Install the following:

- Return spring
- Shock linkage (page 13-21)
- Rear wheel (page 13-10)

After installing the swingarm, check and adjust the following:

- Drive chain (page 3-17)
- Rear brake (page 3-20)
- Rear suspension (page 3-24)



# 14. ELECTRICAL SYSTEM

---

SYSTEM DIAGRAM.....	14-2	IGNITION COIL .....	14-8
SERVICE INFORMATION .....	14-3	ICM (IGNITION CONTROL MODULE) .....	14-9
TROUBLESHOOTING .....	14-4	ENGINE STOP BUTTON .....	14-9
IGNITION SYSTEM INSPECTION.....	14-5	IGNITION SWITCH .....	14-10
IGNITION TIMING.....	14-8		

# ELECTRICAL SYSTEM

## SYSTEM DIAGRAM

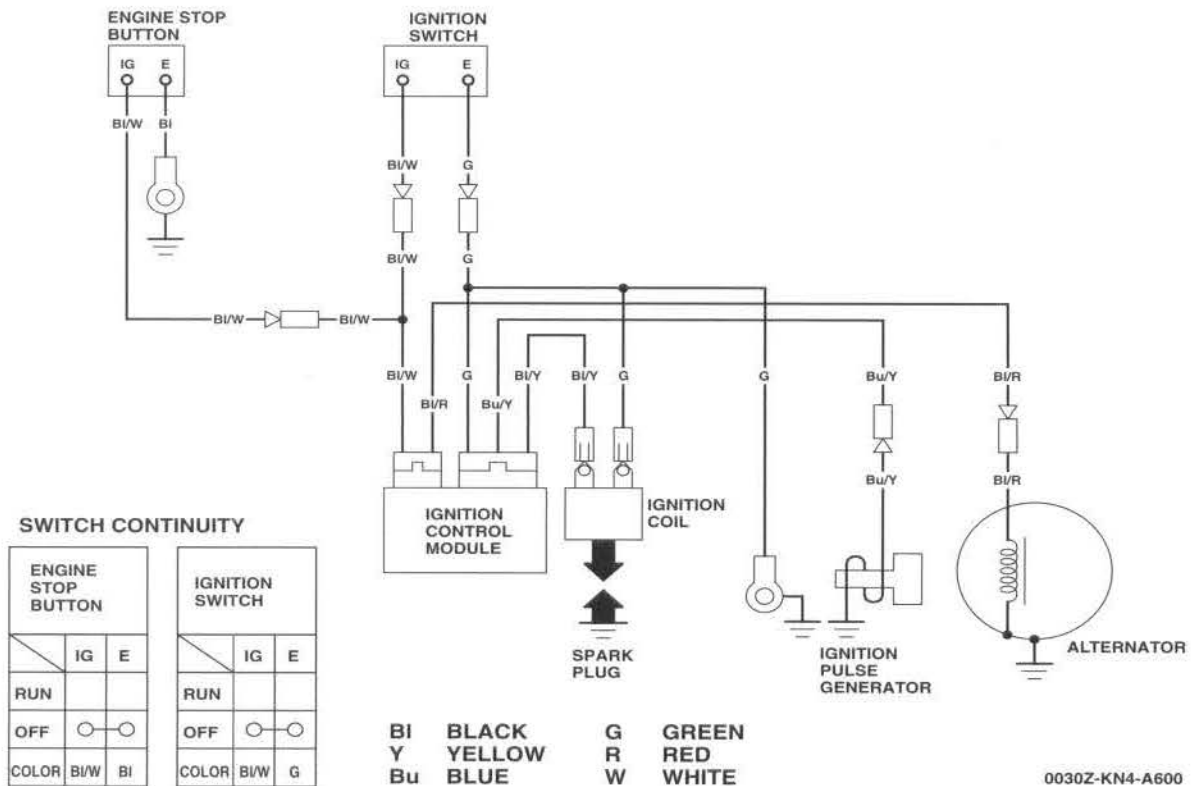
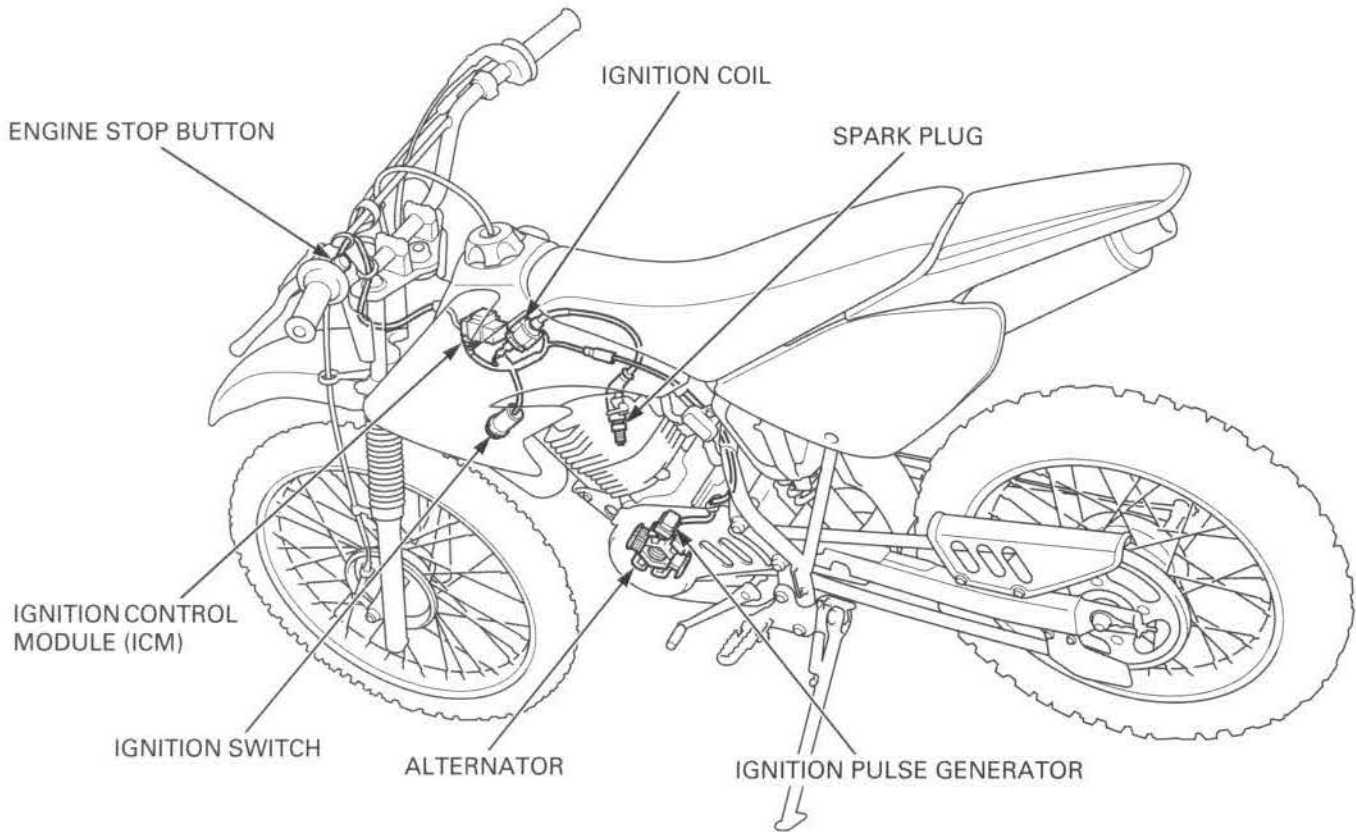

0030Z-KN4-A600

## SERVICE INFORMATION

### GENERAL

#### NOTICE

- The Ignition Control Module (ICM) may be damaged if dropped. Also, if the connector is disconnected when current is flowing, the excessive voltage may damage the module. Always turn off the engine stop switch before servicing.
- Use a spark plug of the correct heat range. Using a spark plug with an incorrect heat range can damage the engine.
- When servicing the ignition system, always follow the steps in the troubleshooting sequence on page 14-4.
- The ignition timing does not normally need to be adjusted since the Ignition Control Module (ICM) is factory preset.
- A faulty ignition system is often related to poor connections. Check those connections before proceeding.

### SPECIFICATION

ITEM		SPECIFICATION	
Spark plug	Standard	NGK	CR7HSA
		DENSO	U22FSR-U
	For cold climate/below (5°C/41°F)	NGK	CR6HSA
		DENSO	U20FSR-U
	For extended high speed riding	NGK	CR8HSA
	DENSO	U24FSR-U	
Spark plug gap		0.6 – 0.7 (0.024 – 0.028)	
Ignition coil primary peak voltage		100 V minimum	
Alternator exciter coil peak voltage		100 V minimum	
Ignition pulse generator peak voltage		0.7 V minimum	
Ignition timing ("F" mark)		15.5° BTDC / at 1,400 rpm	

### TOOLS

Peak voltage adaptor  
07HGJ-0020100 (not available in  
U.S.A.)

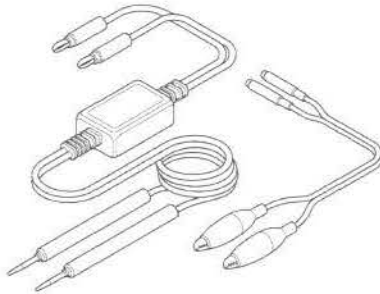

with commercially available digital  
multimeter (impedance 10 MΩ/min-  
imum)

IgnitionMate Peak voltage tester  
MTP07-0286 (U.S.A. only)

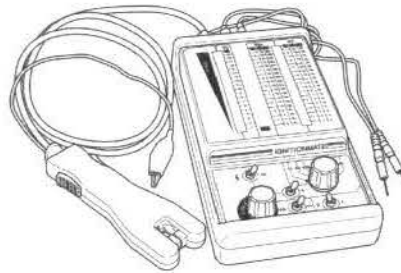

## ELECTRICAL SYSTEM

# TROUBLESHOOTING

- Inspect the following before diagnosing the system.
  - Faulty spark plug
  - Loose spark plug cap or spark plug wire connection
  - Water in the spark plug cap (leaking ignition coil secondary voltage)

## IGNITION SYSTEM

### No spark at plug

	Unusual condition	Probable cause (check in numerical order)
Ignition coil primary voltage	Low peak voltage.	<ol style="list-style-type: none"><li>1. The multimeter impedance is too low; below 10 M<math>\Omega</math>/DCV.</li><li>2. Cranking speed is too slow. (Operating force of the kickstarter is weak.)</li><li>3. The sampling time of the tester and measured pulse were not synchronized. (System is normal if measured voltage is over the standard voltage at least once.)</li><li>4. Poorly connected connectors or an open circuit in ignition system.</li><li>5. Faulty exciter coil. (Measure the peak voltage.)</li><li>6. Faulty ignition coil.</li><li>7. Faulty ICM (in case when above No. 1 – 6 are normal).</li></ol>
	No peak voltage.	<ol style="list-style-type: none"><li>1. Incorrect peak voltage adapter connections.</li><li>2. Short circuit in the Black/white wire.</li><li>3. An open circuit or loose connection in Green wire.</li><li>4. Faulty ignition switch and/or engine stop switch.</li><li>5. Loose or poorly connected ICM connectors.</li><li>6. Open circuit or poor connection in ground wire of the ICM.</li><li>7. Faulty peak voltage adaptor.</li><li>8. Faulty exciter coil. (Measure the peak voltage.)</li><li>9. Faulty ignition pulse generator. (Measure the peak voltage.)</li><li>10. Faulty ICM (in case when above No.1 – 9 are normal).</li></ol>
	Peak voltage is normal, but no spark jumps at the plug.	<ol style="list-style-type: none"><li>1. Faulty spark plug or leaking ignition coil secondary current.</li><li>2. Faulty ignition coil.</li></ol>
Exciter coil	Low peak voltage.	<ol style="list-style-type: none"><li>1. The multimeter impedance is too low.</li><li>2. Cranking speed is too slow. (Operating force of the kickstarter is weak.)</li><li>3. The sampling time of the tester and measured pulse were not synchronized. (System is normal if measured voltage is over the standard voltage at least once.)</li><li>4. Faulty exciter coil (in case when above No.1 – 3 are normal).</li></ol>
	No peak voltage.	<ol style="list-style-type: none"><li>1. Faulty peak voltage adaptor.</li><li>2. Faulty exciter coil.</li></ol>
Ignition pulse generator	Low peak voltage.	<ol style="list-style-type: none"><li>1. The multimeter impedance is too low.</li><li>2. Cranking speed is too slow. (Operating force of the kickstarter is weak.)</li><li>3. The sampling time of the tester and measured pulse were not synchronized. (System is normal if measured voltage is over the standard voltage at least once.)</li><li>4. Faulty ignition pulse generator (in case when above No.1 – 3 are normal).</li></ol>
	No peak voltage.	<ol style="list-style-type: none"><li>1. Faulty peak voltage adaptor.</li><li>2. Faulty ignition pulse generator.</li></ol>

## IGNITION SYSTEM INSPECTION

- If there is no spark at the spark plug, check all connections for loose or poor contact before measuring each peak voltage.
- If using the peak voltage adaptor, use a commercially available digital multimeter with an impedance of 10 M $\Omega$ /DCV minimum.
- The display value differs depending upon the internal impedance of the multimeter.
- If using peak voltage tester (U.S.A. only), follow the manufacturer's instructions.

Connect the peak voltage adaptor to the digital multimeter, or use the peak voltage tester (U.S.A. only).

*If using the peak voltage tester (U.S.A. only), follow the manufacturer's instruction.*

### TOOLS:

#### IgnitionMate Peak voltage tester

MTP-07-0286

(U.S.A. only) or

#### Peak voltage adaptor

07HGJ-0020100

(Not available in U.S.A.)

with commercially available digital multimeter (impedance 10 M $\Omega$ /DCV minimum)

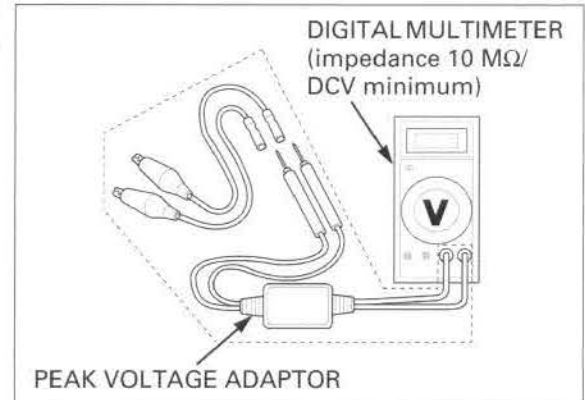

### IGNITION COIL PRIMARY PEAK VOLTAGE

- Check all system connections before inspection. If the system is disconnected, incorrect peak voltage might be measured.
- Check cylinder compression and make sure the spark plug is installed correctly.

Shift the transmission into neutral.

Disconnect the spark plug cap from the spark plug.

Connect a known good spark plug to the spark plug cap and ground the spark plug to the cylinder as done in a spark test.

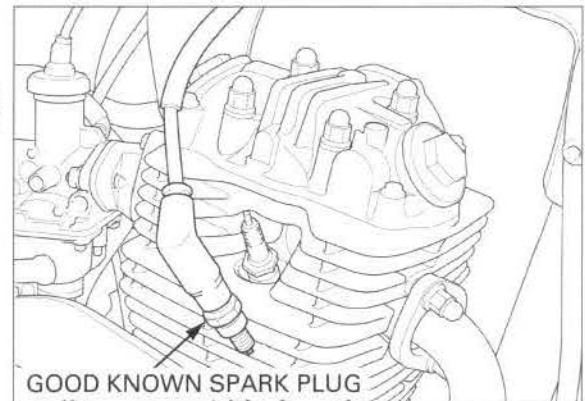

## ELECTRICAL SYSTEM

With the ignition coil primary wire connected, connect the peak voltage adaptor or peak voltage tester to the ignition coil.

### TOOLS:

**IgnitionMate Peak voltage tester**

**MTP-07-0286**

**(U.S.A. only) or**

**Peak voltage adaptor**

**07HGJ-0020100**

**(Not available in U.S.A.)**

**with commercially available digital multimeter  
(impedance 10 M $\Omega$ /DCV minimum)**

### CONNECTION:

**Black/yellow terminal (+) – Body ground (-)**

Turn the ignition switch to "ON".

*Avoid touching the  
spark plug or tester  
probes to prevent  
electric shock.*

Crank the engine with kickstarter and read ignition coil primary peak voltage.

**PEAK VOLTAGE: 100 V minimum**

If the peak voltage is abnormal, check for an open circuit or poor connection in Black/Yellow wire.

If not defects are found in the harness, refer to the troubleshooting chart on page 14-4.

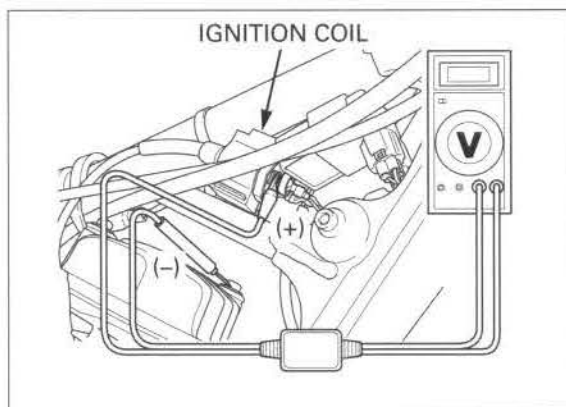

## ALTERNATOR EXCITER COIL PEAK VOLTAGE

- Check cylinder compression and make sure the spark plug is installed correctly.

Remove the fuel tank (page 2-4).

Disconnect the 2P and 4P connectors from the ICM.

Connect the peak voltage adaptor or peak voltage tester probes to the 2P connector terminal of the wire harness side and body ground.

### TOOLS:

**IgnitionMate Peak voltage tester**

**MTP-07-0286**

**(U.S.A. only) or**

**Peak voltage adaptor**

**07HGJ-0020100**

**(Not available in U.S.A.)**

**with commercially available digital multimeter  
(impedance 10 M $\Omega$ /DCV minimum)**

### CONNECTION:

**Black/red terminal (+) – Body ground (-)**

Shift the transmission into neutral.

*Avoid touching the  
spark plug or tester  
probes to prevent  
electric shock.*

Crank the engine with the kickstarter and read the peak voltage.

**PEAK VOLTAGE: 100 V minimum**

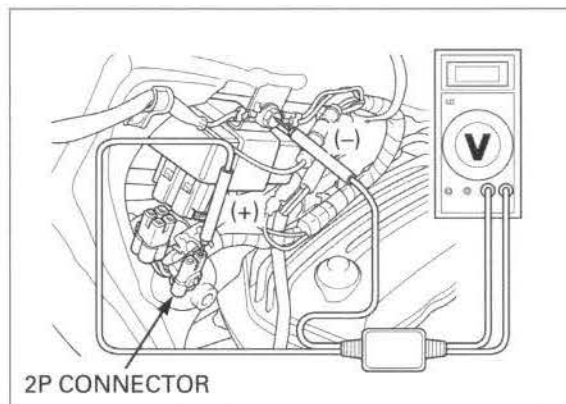

If the peak voltage measured at the ICM connector is abnormal, measure the peak voltage at the alternator exciter coil connector.

Remove the fuel tank (page 2-4).

Disconnect the alternator exciter coil connector and connect the tester probes to the Black/Red terminal (exciter coil side) and body ground.

In the same manner as at the ICM connector, measure the peak voltage and compare it to the voltage measured at the ICM connector.

- If the peak voltage measured at the ICM is abnormal and the one measured at the alternator exciter coil is normal, the wire harness has an open or short circuit, or loose connection.
- If both peak voltage measurements are abnormal, check each item in the troubleshooting chart (page 14-4). If all items are normal, the alternator exciter coil is faulty (See page 10-5 for stator replacement).

### IGNITION PULSE GENERATOR PEAK VOLTAGE

- Check cylinder compression and make sure the spark plug is installed correctly.

Disconnect the 2P and 4P connectors from the ICM. Connect the peak voltage adaptor or peak voltage tester probes to the connector terminal of the wire harness side and body ground.

#### TOOLS:

**IgnitionMate Peak voltage tester**

MTP-07-0286  
(U.S.A. only) or  
07HGJ-0020100  
(Not available in U.S.A.)

**Peak voltage adaptor**

07HGJ-0020100  
(Not available in U.S.A.)

with commercially available digital multimeter  
(impedance 10 M $\Omega$ /DCV minimum)

#### CONNECTION:

Blue/yellow terminal (+) – Body ground (-)

Crank the engine with the kickstarter and read the peak voltage.

**PEAK VOLTAGE: 0.7 V minimum**

If the peak voltage measured at the ICM connector is abnormal, measure the peak voltage at the pulse generator connector.

Remove the fuel tank (page 2-4).

Disconnect the ignition pulse generator connector and connect the tester probes to the Blue/yellow terminals of the ignition pulse generator side and body ground.

ALTERNATOR EXCITER COIL CONNECTOR

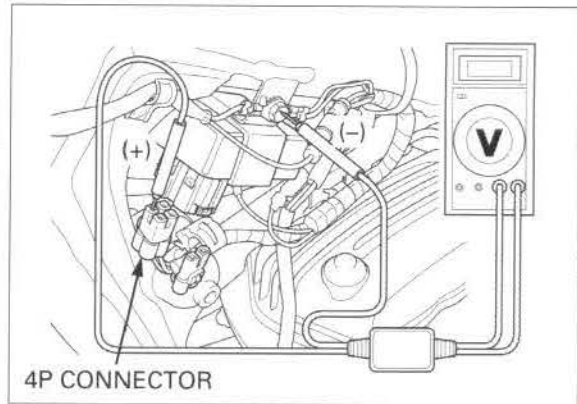
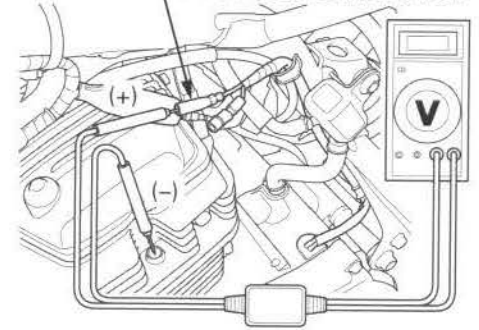

4P CONNECTOR

PULSE GENERATOR CONNECTOR

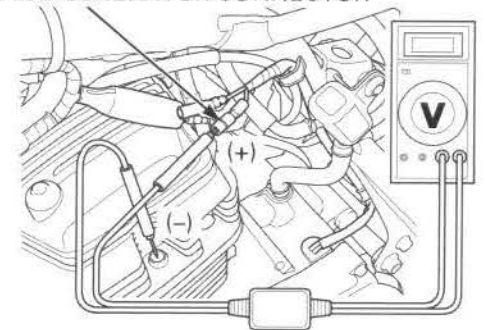



## ELECTRICAL SYSTEM

In the same manner as at the ICM connector, measure the peak voltage and compare it to the voltage measured at the ICM connector.

- If the peak voltage measured at the ICM is abnormal and the one measured at the ignition pulse generator is normal, the wire harness has an open or short circuit, or loose connection.
- If both peak voltage measurements are abnormal, check each item in the troubleshooting chart (page 14-4). If all items are normal, the ignition pulse generator is faulty (See page 10-5 for ignition pulse generator replacement).

## IGNITION TIMING

- Read the manufacturer's instructions for timing light operation.

Warm up the engine.

Stop the engine and remove the left crankcase cover (page 10-4).

Connect a timing light to the spark plug wire.

Start the engine and let it 1,400 rpm.

The ignition timing is correct if the "F" mark on the flywheel aligns with the index notch on the left crankcase.

Increase the engine speed by turning the throttle stop screw and make sure the "F" mark begins to move clockwise.

Install the left crankcase cover (page 10-8).

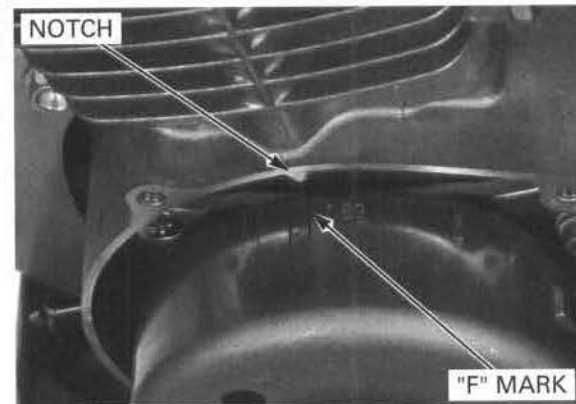

## IGNITION COIL

### REMOVAL/INSTALLATION

Remove the fuel tank (page 2-4).

Disconnect the spark plug cap from the spark plug.

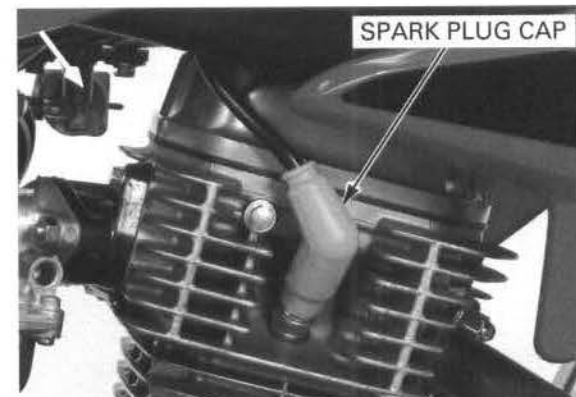

Disconnect the primary wires from the ignition coil.  
Remove the ignition coil.  
Installation is in the reverse order of removal.

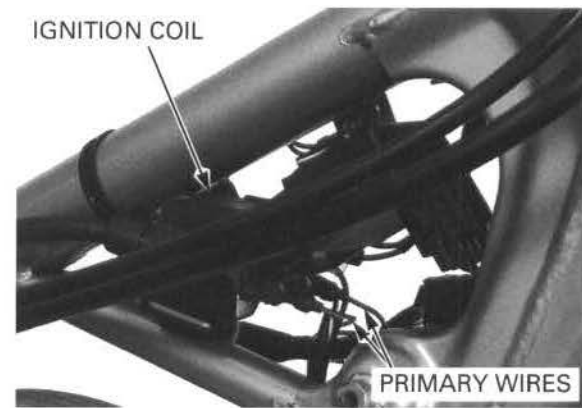

## ICM (IGNITION CONTROL MODULE)

### REMOVAL/INSTALLATION

Remove the fuel tank (page 2-4).  
Disconnect the ignition control module (ICM) connectors.  
Installation is in the reverse order of removal.  
Remove the ICM from the frame.

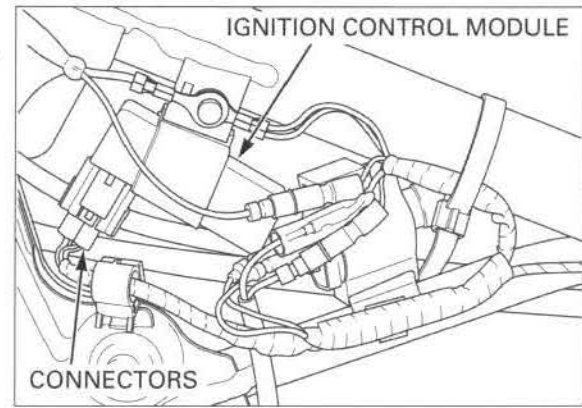

## ENGINE STOP BUTTON

### INSPECTION

Remove the fuel tank (page 2-4).  
Disconnect the engine stop button connectors.

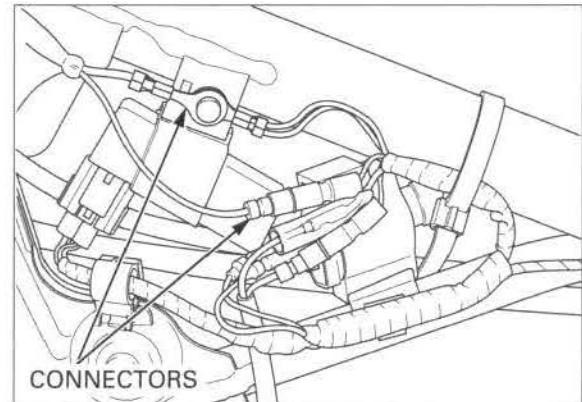

Check for continuity between the connector terminals of the engine stop switch side.

There should be continuity when the button is pressed and no continuity when released.

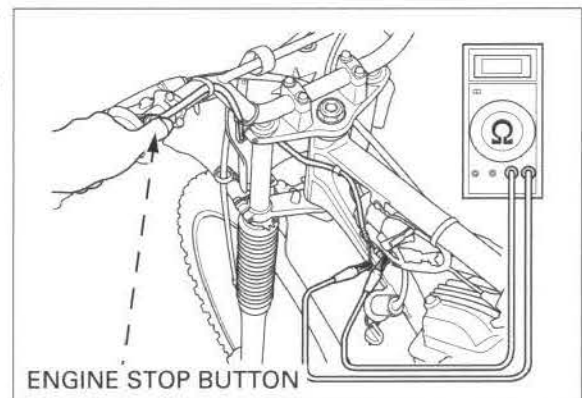

## IGNITION SWITCH

### INSPECTION

Remove the fuel tank (page 2-4).

Disconnect the ignition switch connectors.

Check for continuity between the connector terminals of the ignition switch side.

There should be no continuity with the ignition switch to "ON" and continuity with the ignition switch to "OFF".

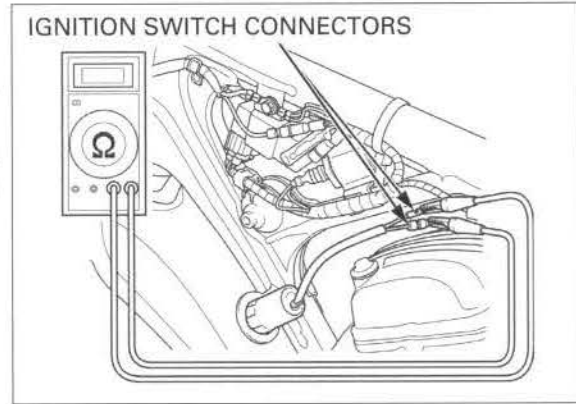

### REMOVAL/INSTALLATION

Remove the fuel tank (page 2-4).

Disconnect the ignition switch connectors.

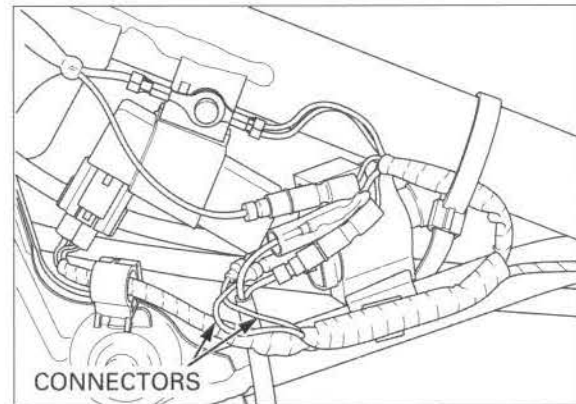

Release the tabs on the ignition switch body and remove the ignition switch.

*During installation, align the guide on the ignition switch with the groove on the bracket.*

Installation is in the reverse order of removal.

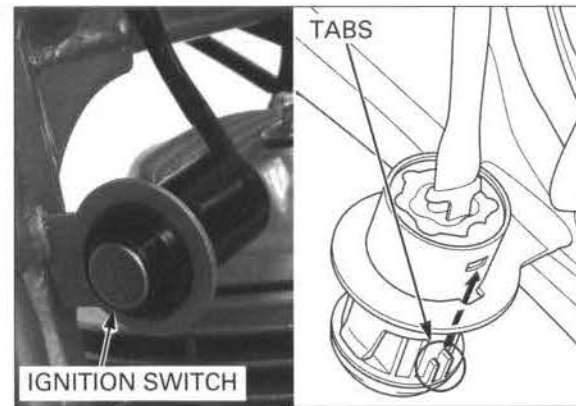

# 15. WIRING DIAGRAM

---

WIRING DIAGRAM ..... 15-2

15

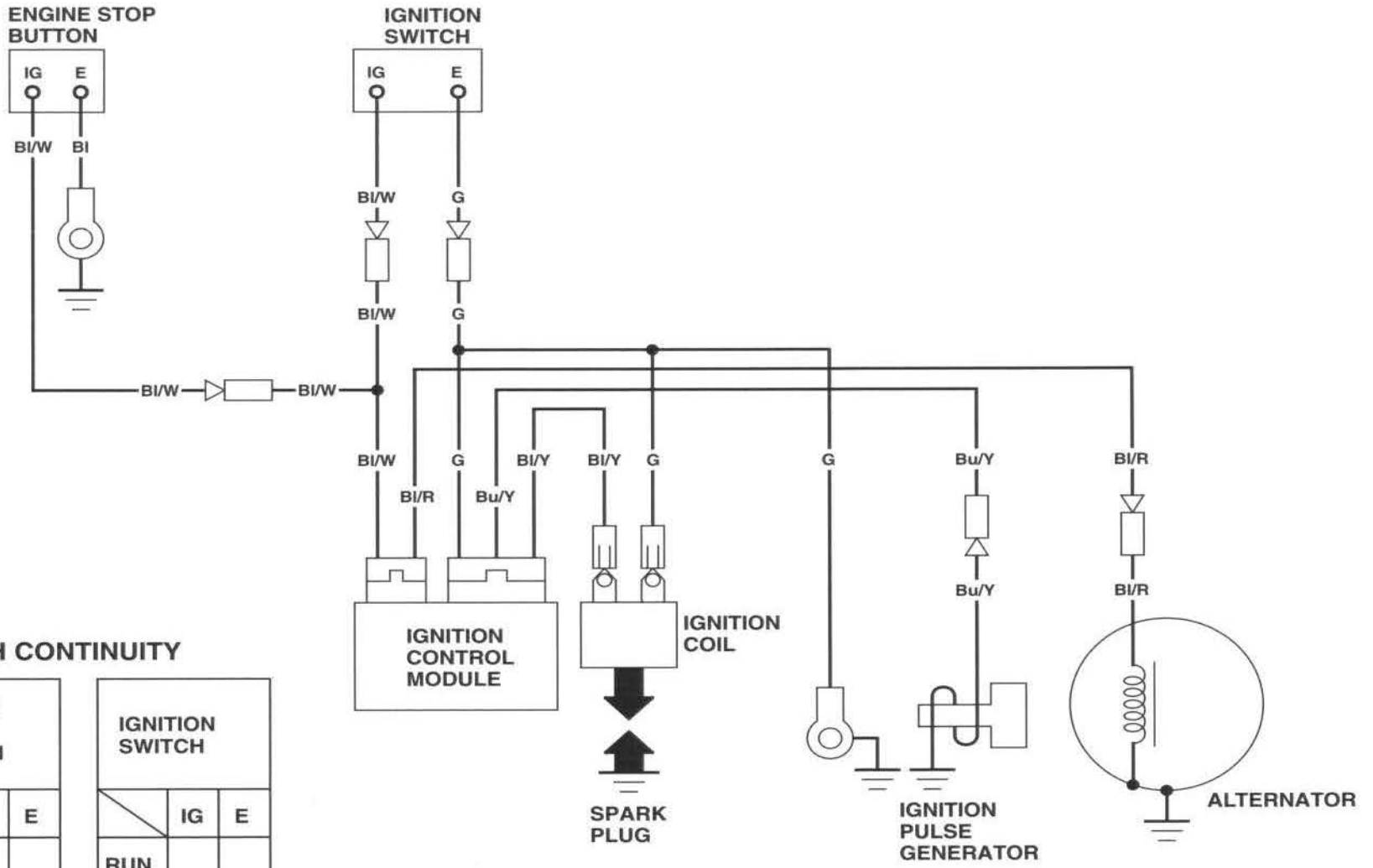

**SWITCH CONTINUITY**

ENGINE STOP BUTTON		IG	E
RUN			
OFF	○—○		
COLOR	BI/W	BI	

IGNITION SWITCH		IG	E
RUN			
OFF	○—○		
COLOR	BI/W	G	

**BI** BLACK  
**Y** YELLOW  
**Bu** BLUE  
**G** GREEN  
**R** RED  
**W** WHITE

0030Z-KN4-A600

# 16. TROUBLESHOOTING

---

ENGINE DOES NOT START OR IS HARD TO  
START ..... 16-2

ENGINE LACKS POWER ..... 16-3

POOR PERFORMANCE AT LOW AND IDLE  
SPEED..... 16-5

POOR PERFORMANCE AT  
HIGH SPEED ..... 16-5

POOR HANDLING ..... 16-6

## ENGINE DOES NOT START OR IS HARD TO START

### 1. Carburetor Inspection

Check the fuel flow to carburetor.

*Is fuel reaching the carburetor?*

- NO** – • Clogged fuel hose or fuel strainer screen  
• Sticking float valve  
• Clogged fuel tank breather hose

**YES** – GO TO STEP 2.

### 2. Spark Plug Inspection

Remove and inspect spark plug.

*Is the spark plug burning condition wet?*

**NO** – GO TO STEP 4.

**YES** – GO TO STEP 3.

### 3. Fuel system Inspection

Inspect the fuel system.

*Is the fuel system in good condition?*

- NO** – • Flooded carburetor  
• Throttle valve open  
• Air cleaner dirty  
• Improper carburetor settings

**YES** – GO TO STEP 4.

### 4. Spark Test

Perform a spark test.

*Is there a good spark?*

- NO** – • Incorrect spark plug gap  
• Incorrect spark plug heat range  
• Faulty spark plug  
• Broken or shorted spark plug wire  
• Faulty ignition control module  
• Broken or shorted ignition coil  
• Faulty ignition pulse generator  
• Faulty exciter coil  
• Faulty ignition switch  
• Faulty engine stop button  
• Loose or disconnected ignition system wires

**YES** – GO TO STEP 5.

### 5. Cylinder Compression Inspection

Test the cylinder compression.

*Is the compression normal?*

- NO** – • Valve stuck open  
• Valve clearance too small  
• Worn cylinder and piston rings  
• Leaking/damaged cylinder head gasket  
• Seized valve  
• Improper valve timing

**YES** – GO TO STEP 6.

### 6. Engine Start Condition

Start by following the normal procedure.

*Does the engine start but then stop?*

- YES** – • Improper choke operation  
• Carburetor incorrectly adjusted  
• Intake pipe leaking  
• Improper ignition timing (faulty ICM or ignition coil or ignition pulse generator)  
• Fuel contaminated

## ENGINE LACKS POWER

### 1. Drive Train Inspection

Raise wheel off the ground and spin by hand.

**Does the wheel spin freely?**

- NO** – • Brake dragging  
• Worn or damaged wheel bearings  
• Bent axle  
• Improper drive chain slack adjustment

**YES** – GO TO STEP 2.

### 2. Tire Pressure Inspection

Check the tire pressure.

**Is the tire pressure correct?**

- NO** – • Faulty tire valve  
• Punctured tire

**YES** – GO TO STEP 3.

### 3. Clutch Inspection

Accelerate rapidly from low to second.

**Does the engine speed change accordingly when clutch is released?**

- NO** – • Clutch slipping  
• Worn clutch discs/plates  
• Warped clutch discs/plates  
• Weak clutch spring  
• Additive in engine oil

**YES** – GO TO STEP 4.

### 4. Engine Performance Inspection

Accelerate lightly.

**Does the engine speed increase?**

- NO** – • Choke valve closed  
• Clogged air cleaner  
• Restricted fuel flow  
• Clogged muffler  
• Clogged fuel tank breather hose

**YES** – GO TO STEP 5.

### 5. Ignition Timing Inspection

Check the ignition timing.

**Is the ignition timing normal?**

- NO** – • Faulty ignition control module  
• Faulty ignition pulse generator

**YES** – GO TO STEP 6.

### 6. Cylinder compression Inspection

Test the cylinder compression.

**Is the compression normal?**

- NO** – • Valve stuck open  
• Worn cylinder and piston rings  
• Leaking/damaged head gasket  
• Improper valve timing

**YES** – GO TO STEP 7.



### 7. Carburetor Inspection

Check the carburetor for clogs.

**Is the carburetor clogged?**

**YES** – Carburetor not serviced frequently enough

**NO** – GO TO STEP 8.

### 8. Spark Plug Inspection

Remove and inspect the spark plug.

**Is the spark plug in good condition?**

**NO** –

- Plug not serviced frequently enough
- Incorrect spark plug heat range
- Incorrect spark plug gap

**YES** – GO TO STEP 9.

### 9. Engine Oil Inspection

Check the oil level and condition.

**Is the engine oil in good condition?**

**NO** –

- Oil level too high
- Oil level too low
- Contaminated oil

**YES** – GO TO STEP 10.

### 10. Lubrication Inspection

Remove cylinder head cover and inspect lubrication.

**Is the valve train lubricated properly?**

**NO** –

- Clogged oil passage
- Faulty oil

**YES** – GO TO STEP 11.

### 11. Over Heating Inspection

Check for engine over heating.

**Is the engine over heating?**

**YES** –

- Excessive carbon build-up in combustion chamber
- Use of poor quality fuel
- Clutch slipping
- Lean fuel mixture
- Wrong type of fuel

**NO** – GO TO STEP 12.

### 12. Engine Knocking Inspection

Accelerate or run at high speed.

**Does the engine knock?**

**YES** –

- Worn piston and cylinder
- Wrong type of fuel
- Excessive carbon build-up in combustion chamber
- Ignition timing too advanced (faulty ignition control module)
- Lean fuel mixture

**NO** – Engine does not knock

## POOR PERFORMANCE AT LOW AND IDLE SPEED

### 1. Carburetor Pilot Screw Inspection

Check the carburetor pilot screw adjustment.

**Is the pilot screw correct?**

**NO** – (page 5-18)

**YES** – GO TO STEP 2.

### 2. Intake Pipe Leaking Inspection

Check for leaks in the intake pipe.

**Is there leaking?**

**YES** – • Loose carburetor mounting nut  
• Damaged insulator

**NO** – GO TO STEP 3.

### 3. Spark Test

Perform a spark test.

**Is there a good spark?**

**NO** – • Faulty carbon or wet fouled spark plug  
• Faulty ignition control module  
• Faulty ignition coil  
• Broken or shorted spark plug wire  
• Faulty engine stop button  
• Faulty ignition pulse generator  
• Faulty exciter coil  
• Faulty ignition switch  
• Loose or disconnected ignition system wires

**YES** – GO TO STEP 4.

### 4. Ignition Timing Inspection

Check the ignition timing.

**Is the ignition timing normal?**

**NO** – Improper ignition timing (Faulty ignition control module)

## POOR PERFORMANCE AT HIGH SPEED

### 1. Fuel Line Inspection

Disconnect the fuel hose at the carburetor.

**Does the fuel flow freely?**

**NO** – • Clogged fuel line  
• Clogged fuel tank breather hose  
• Clogged fuel strainer screen

**YES** – GO TO STEP 2.

### 2. Carburetor Inspection

Remove the carburetor and check for clogged jets.

**Are the jets clogged?**

**YES** – Clean

**NO** – GO TO STEP 3.

### 3. Valve Timing Inspection

Check the valve timing.

**Is the valve timing correct?**

**NO** – Cam sprocket not installed properly

**YES** – GO TO STEP 4.

## TROUBLESHOOTING

---

### 4. Ignition Timing Inspection

Check the ignition timing.

*Is the ignition timing normal?*

**NO** – • Faulty ignition control module  
• Faulty ignition pulse generator

**YES** – GO TO STEP 5.

### 5. Valve Spring Inspection

Check for the valve springs.

*Is the valve spring free length normal?*

**NO** – Faulty valve spring

**YES** – Not weak

## POOR HANDLING

### Steering is heavy

- Steering bearing adjusting nut too tight
- Damaged steering head bearings

### Either wheel is wobbling

- Excessive wheel bearing play
- Bent rim
- Improperly installed wheel hub
- Swingarm pivot bearing excessively worn
- Bent frame

### The motorcycle pulls to one side

- Front and rear wheel not aligned
- Faulty shock absorber
- Bent fork
- Bent swingarm
- Bent axle
- Bent frame

AIR CLEANER	3-10	FRONT FENDER	2-5
AIR CLEANER HOUSING	5-6	FRONT WHEEL	12-10
AIR SCREW ADJUSTMENT (CRF80F)	5-19	FRONT WHEEL/BRAKE/SUSPENSION/STEERING SPECIFICATIONS	1-11
BODY PANEL LOCATIONS	2-2	FUEL LINE	3-9
BRAKE PEDAL	13-15	FUEL SYSTEM SPECIFICATIONS (CRF100F)	1-7
BRAKE SHOE WEAR	3-20	FUEL SYSTEM SPECIFICATIONS (CRF80F)	1-7
BRAKE SYSTEM	3-20	FUEL TANK	2-4
CABLE & HARNESS ROUTING	1-17	GEARSHIFT LINKAGE	9-12
CAM CHAIN TENSION	3-15	GENERAL SPECIFICATIONS	1-5
CAMSHAFT INSTALLATION	7-18	HANDLEBAR	12-6
CAMSHAFT REMOVAL	7-6	HIGH ALTITUDE ADJUSTMENT	5-20
CARBURETOR ASSEMBLY	5-12	ICM (IGNITION CONTROL MODULE)	14-9
CARBURETOR DISASSEMBLY	5-8	IGNITION COIL	14-8
CARBURETOR INSTALLATION	5-15	IGNITION SWITCH	14-10
CARBURETOR REMOVAL	5-6	IGNITION SYSTEM INSPECTION	14-5
CLUTCH	9-7	IGNITION TIMING	14-8
CLUTCH SYSTEM	3-22	KICKSTARTER	11-18
CLUTCH/GEARSHIFT LINKAGE SPECIFICATIONS	1-10	LEFT CRANKCASE COVER INSTALLATION	10-8
COMPONENT LOCATION		LEFT CRANKCASE COVER REMOVAL	10-4
ALTERNATOR	10-2	LUBRICATION & SEAL POINTS	1-15
CLUTCH/GEARSHIFT LINKAGE	9-2	LUBRICATION SYSTEM DIAGRAM	4-2
CRANKSHAFT/TRANSMISSION/KICKSTARTER		LUBRICATION SYSTEM SPECIFICATIONS	1-7
KICKSTARTER	11-2	MAINTENANCE SCHEDULE	3-5
CYLINDER HEAD/VALVES	7-2	MODEL IDENTIFICATION	1-2
CYLINDER/PISTON	8-2	MUD GUARD	2-6
ENGINE REMOVAL/INSTALLATION	6-2	MUFFLER/EXHAUST PIPE	2-7
FRONT WHEEL/BRAKE/SUSPENSION/STEERING	12-2	NUMBER PLATE	2-5
FUEL SYSTEM	5-2	NUTS, BOLTS, FASTENERS	3-25
REAR WHEEL/BRAKE/SUSPENSION	13-2	OIL PUMP	4-5
CRANKCASE ASSEMBLY	11-19	PILOT SCREW ADJUSTMENT (CRF100F)	5-18
CRANKCASE BEARING REPLACEMENT	11-12	PISTON INSTALLATION	8-9
CRANKCASE PROTECTOR	2-6	PISTON REMOVAL	8-6
CRANKCASE SEPARATION	11-7	PISTON/PISTON RING INSPECTION	8-7
CRANKCASE/TRANSMISSION/KICKSTARTER SPECIFICATIONS (CRF100F)	1-10	POOR HANDLING	16-6
CRANKCASE/TRANSMISSION/KICKSTARTER SPECIFICATIONS (CRF80F)	1-11	POOR PERFORMANCE AT HIGH SPEED	16-5
CRANKSHAFT	11-8	POOR PERFORMANCE AT LOW AND IDLE SPEED	16-5
CYLINDER COMPRESSION TEST	7-6	PRIMARY DRIVE GEAR	9-10
CYLINDER HEAD ASSEMBLY	7-16	REAR BRAKE	13-12
CYLINDER HEAD DISASSEMBLY	7-10	REAR FENDER	2-5
CYLINDER HEAD INSPECTION	7-11	REAR WHEEL	13-6
CYLINDER HEAD INSTALLATION	7-17	REAR WHEEL/BRAKE/SUSPENSION SPECIFICATIONS	1-12
CYLINDER HEAD OIL CHECK BOLT	4-5	RIGHT CRANKCASE COVER INSTALLATION	9-14
CYLINDER HEAD REMOVAL	7-10	RIGHT CRANKCASE COVER REMOVAL	9-5
CYLINDER HEAD/VALVES SPECIFICATIONS	1-8	SEAT	2-3
CYLINDER INSPECTION	8-5	SERVICE INFORMATION	
CYLINDER INSTALLATION	8-10	ALTERNATOR	10-3
CYLINDER REMOVAL	8-5	CLUTCH/GEARSHIFT LINKAGE	9-3
CYLINDER/PISTON SPECIFICATIONS (CRF100F)	1-9	CRANKSHAFT/TRANSMISSION/KICKSTARTER	11-3
CYLINDER/PISTON SPECIFICATIONS (CRF80F)	1-9	CYLINDER HEAD/VALVES	7-3
DRIVE CHAIN	3-17	CYLINDER/PISTON	8-3
DRIVE CHAIN SLIDER	3-19	ELECTRICAL SYSTEM	14-3
ELECTRICAL SYSTEM SPECIFICATIONS	1-12	ENGINE REMOVAL/INSTALLATION	6-3
EMISSION CONTROL SYSTEMS	1-21	FRAME/BODY PANELS/EXHAUST SYSTEM	2-2
ENGINE & FRAME TORQUE VALUES	1-13	FRONT WHEEL/BRAKE/SUSPENSION/STEERING	12-3
ENGINE DOES NOT START OR IS HARD TO START	16-2	FUEL SYSTEM	5-3
ENGINE IDLE SPEED	3-16	LUBRICATION SYSTEM	4-3
ENGINE INSTALLATION	6-7	MAINTENANCE	3-2
ENGINE LACKS POWER	16-3	REAR WHEEL/BRAKE/SUSPENSION	13-3
ENGINE OIL	3-13	SERVICE RULES	1-2
ENGINE OIL STAINER SCREEN	3-15	SHOCK ABSORBER	13-18
ENGINE REMOVAL	6-4	SHOCK LINKAGE	13-19
ENGINE STOP BUTTON	14-9	SIDE COVER	2-3
FLYWHEEL	10-4	SIDE STAND	3-23
FORK	12-18	SPARK ARRESTER	3-24
FRONT BRAKE	12-15		

## INDEX

---

SPARK PLUG.....	3-11	CRANKSHAFT/TRANSMISSION/ KICKSTARTER.....	11-6
STANDARD TORQUE VALUES.....	1-13	CYLINDER HEAD/VALVES.....	7-5
STATOR.....	10-5	CYLINDER/PISTON.....	8-4
STATOR BASE.....	10-7	ELECTRICAL SYSTEM.....	14-4
STEERING HEAD BEARINGS.....	3-26	FRAME/BODY PANELS/EXHAUST SYSTEM.....	2-2
STEERING STEM.....	12-26	FRONT WHEEL/BRAKE/SUSPENSION/ STEERING.....	12-5
SUSPENSION.....	3-23	FUEL SYSTEM.....	5-5
SWINGARM.....	13-22	LUBRICATION SYSTEM.....	4-4
SYSTEM DIAGRAM		REAR WHEEL/BRAKE/SUSPENSION.....	13-5
ELECTRICAL SYSTEM.....	14-2	VALVE CLEARANCE.....	3-12
TANK SHROUD.....	2-3	VALVE GUIDE REPLACEMENT.....	7-13
THROTTLE OPERATION.....	3-9	VALVE SEAT INSPECTION/REFACING.....	7-13
TRANSMISSION ASSEMBLY/INSTALLATION.....	11-15	WHEELS/TIRES.....	3-25
TRANSMISSION REMOVAL/DISASSEMBLY.....	11-9	WIRING DIAGRAM.....	15-2
TROUBLESHOOTING			
CLUTCH/GEARSHIFT LINKAGE.....	9-4		