

**INSIDE**

- Bank's chief executives visit the Harapan plants
- Machine of the Year (Great Britain, Germany & Australia)
- Yamaha New Turbo System (a grand dealer convention)
- '80 Baja 1000
- Be No. 1 with a perfect service system!
- Safe riding & psychology (series)

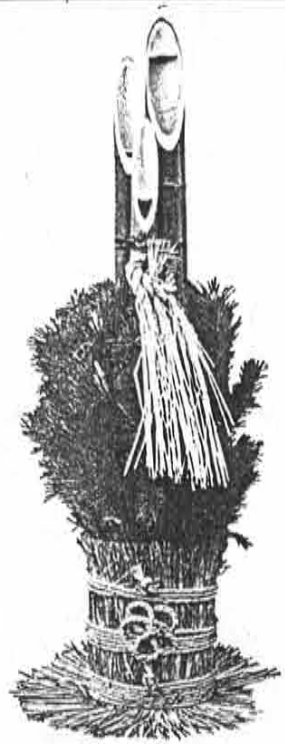

**Kado Matsu**

This is a time-honored practice in Japan. A branch or a pair of branches of a pine tree (matsu) are put up at the entrance to the house to greet the New Year. "Matsu" is evergreen and lives for a long time. For this reason it is an auspicious symbol in Japan. Sometimes pieces of green bamboo and bundled clean straw are used in combination with "matsu" to make up a more decorative "Kado Matsu". May good luck wait upon you this year!

# President Koike Announces Determined Policies for '81

*All efforts will be joined for another big advance*

- The established corporate policy will persistently be followed
- Better quality products to meet customer needs better
- A new target to establish "Yamaha" as the firmer top brand



President Koike sends a new year message, emphasizing that all efforts should be united to attain a new target.

Last year we attained a production target of 2,500,000 bikes. Power products, such as portable generators, multipurpose engines, etc., greatly expanded their market all over the world while marine engines and FRP boats enjoyed a remarkable rise in sales. These business achievements, for which we owed much to overseas distributors and dealers, marked a significant milestone in our 25-year history. We have to make these achievements a springboard to another big advance in 1981.

As you know, our business climate is inevitably influenced by international politics and economy. For instance, it must be taken for granted that the conversion rate of the yen will reach even ¥190 to the dollar in the course of the year. Under whatever circumstances, however, we must persistently follow our long established corporate policy to develop and market a wide range of quality products for our worldwide customers.

To this end, all possible measures will be taken to improve our production and supply system in all aspects by joining the efforts of all work divisions in closer cooperation with our domestic suppliers concerned. Representing our renewed determination to improve the level of our technology, the new Research & Development Center will soon be put into operation. Better quality products will be developed and manufactured in larger quantities, based on an accurate insight into market trends, and they will be supplied to customers within the shortest possible period of time. We must now consider how best to utilize all our capabilities, materials, and money which, I hope will result in overall higher work efficiency. 1981 should be the banner year and let's make it a new target to establish "Yamaha" as the more stabilized leading brand in the industry.

## Smooth Development of Yamaha New Turbo System

Yamaha's technical staff are striving to put the Yamaha New Turbo System to practical use within the shortest possible period of time. High performance is combined with low fuel consumption in this system. (see page 7 for more details)

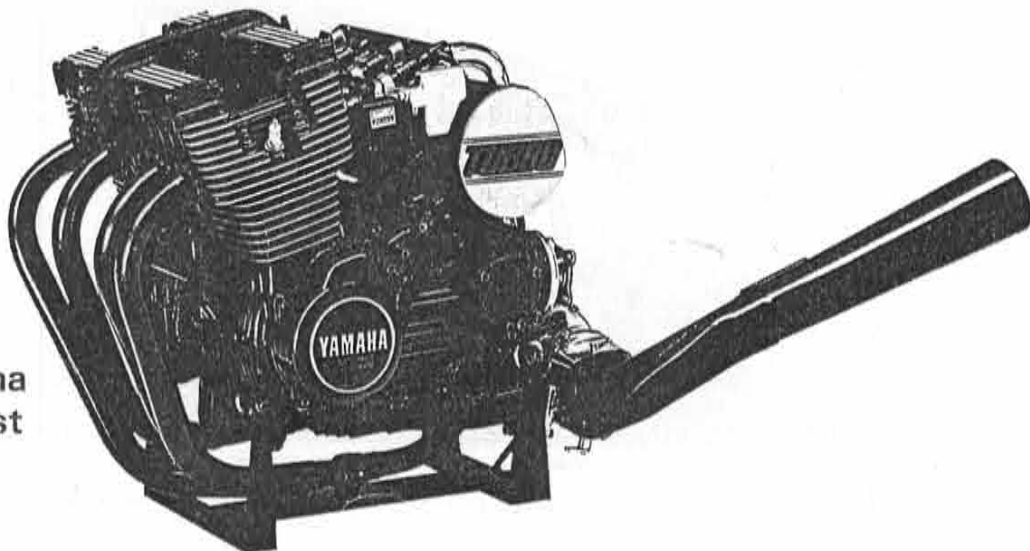

# 1981 motorcycle dealer show

From Canada: The new models in the '81 line were introduced during the recent Canadian dealer meeting which took place for three days in Quebec City. On the evening of the first day there was a reception for all dealers, with Mr. Hisao Koike, President of Yamaha Motor and Mr. Keisuke Abe, President of Yamaha Motor Canada attending. On the second day the presentation of new models was held at the beautiful Grand Theatre and then selected dealers received awards for their outstanding business results. Mr. Gordon Alenbauch, of G.A. Checkpoint, was awarded a briefcase and pen for being Canada's number

one Yamaha dealer for 1979-80. The display area was arranged at the hotel and open for two days, while at the same time dealers could attend information seminars or take one of the many tours offered around historic Quebec City. Many key models were positioned on revolving turntables and some of them were introduced in a dramatic fashion to repeat a sensation in the United States. The staff of Yamaha Motor Canada conducted product surveys on some of the new models in order to gain a great deal of valuable information from all Yamaha dealers.



## Popular Seca 750

From the U.S.A.: The Seca 750 which features a unique computerized monitoring system among its many technical improvements, is introduced under the title of "Motorcycle Monitor in the column of New Products And Processes" of Newsweek dated November 17, 1980. The account reads as follows (extracts): "Motorcyclists who like to know all they can about the machines they ride will appreciate a new piece of equipment on the Seca 750, recently introduced in the United States..."

This new motorcycle has a miniature computer console mounted on its handlebars. The so-called Computerized Monitoring System on the Seca 750 is designed like a scaled-down version of the "intelligent" electronic instrument panels...

Sandwiched between the motorcycle's speedometer and tachometer, this easy-to-read panel indicates the performance condition of seven important functions of the motorcycle.

Each time the rider starts the bike, the computer flashes a liquid-crystal-display (LCD) light to confirm that everything is OK with the battery-fluid level, the engine-oil level, the headlight, taillight, spotlight -- even the side-mounted kickstand...."

## Egyptian traffic police officers visit Yamaha

From Tokyo: The Japanese Government organized a 41-day international traffic police conference in Tokyo starting on Oct. 2, as part of the Colombo Plan, which is aimed at the cooperative economic development of South and Southeast Asia. 12 senior police officers from 10 signatory nations of the Plan took part in this conference, where they discussed important points concerning traffic police administration. The participating nations were: Bangladesh, Egypt, Fiji, Indonesia, Iraq, Mexico, Peru, Philippines, Singapore and Syria. Col. Abd el Salam of Cairo Central Police and Col. Medhat Abbas of Portside

Police, who represented Egypt in this conference, paid their first visit to the Yamaha Safe Driving Promotion Center located in the Yamaha Tokyo Office after the conference was over. Both police officers who are active in the first line of traffic police administration in Egypt are highly appreciative of the merits of Yamaha's safe driving promotion activities, including the learn-to-ride safety program. They talked with Mr. Goro Hirai, General Manager, Mr. Nitta, Manager, and other staff of the Center including Mr. Ogai and Mr. Takahashi, both safe driving instructors.



Col. Abd el Salam (second from the left) and Col. Medhat Abbas (fourth from the left).

## Overseas Yamaha Plant News

### Bank's chief executives visit the Harapan plants

— Always-growing Harapan group —

Last year Yamaha bikes greatly expanded their market in Indonesia as Harapan Motor, Indonesian Yamaha importer and assembler, successfully conducted the series of sales promotion campaigns keeping pace with the smooth supply of products and progressive improvement of after-sale service system based on the results of careful, extensive market survey.

As a result, yearly sales exceeded the 150,000 mark. This has further consolidated Yamaha's position as number one in Indonesia. This year, with the introduction of new quality models to meet customer needs better, the company has firm confidence in attaining even the 200,000 mark.

It is no wonder that such a remarkable growth is becoming a matter for keener attention among financial circles.

Recently, Mr. Meraud, General Manager of Societe Generala, Far East, one of Harapan's main bank, paid his first visit

to the main office of the company in Jakarta, accompanied by Mr. Chavy, General Manager of Singapore Branch. They looked deeply impressed by the clear picture of always-growing Harapan group when they were guided by Mr. Hendra Rahardja, President of Harapan Motor, through the plants of Yamaha Indonesia Motor Manufacturing and Karya Sakti Utama Motor at full capacity for the production of quality bikes and parts.

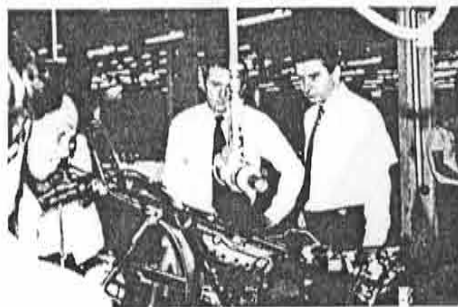

Modern assembly line



President Hendra (left) is guiding Mr. Meraud (third from the left) and Mr. Chavy (second from the left) through the plants.

## A Special fishery course for overseas students

From Iwata: The Kanagawa International Fisheries Training Center, belonging to the Japan International Cooperation Agency (JICA), has conducted its training program for technical students from developing nations since it was founded in April, 1974. Yamaha cooperates with the Center by giving a special fishery course for them. This gives a finishing touch to the student's study in Japan.

This year the fishery course was given for 18 students from 17 nations — Indonesia, Malaysia, Thailand, Fiji, Tonga, Solomon, Turkey, Tunisia, Yemen, Ghana, Kenya, Mauritania, Senegal, Tanzania, Colombia, Peru and Mexico. These students were divided into two groups and learned how to practice young sardine fishery and bottom fish fishery on the Sea of Enshu for 3

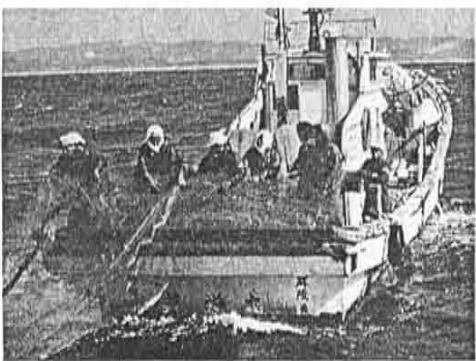

days from Oct. 27 through Oct. 29. Yamaha FRP fishing boats were offered for this training and these students got a chance to learn a lot about these products as well. After the fishery course was over, they made a tour of the Arai Boat Plant and Sanshin Industries (outboard motor plant). What they have learned in Japan will be of great use for these students who are to



take an important role in the promotion of fisheries in their respective nations.

## Actualidades Venemotos

From Venezuela: Venemotos, Venezuelan Yamaha importer with its head office located in Caracas, has recently published the first issue of its periodic bulletin called "Actualidades Venemotos as part of its extensive public relations program. Venezuela" is one of the most important markets for Yamaha products such as motorcycles and outboard motors in South America.

Venemotos (Mr. Andrea Ippolito, Managing Director) and all Yamaha dealers concerned are joining forces to expand the market for Yamaha products, and the newly founded bulletin provides these dealers with a variety of useful news and information concerning "Yamaha", thus serving as an effective means of communication between Venemotos and dealers and also helping to tighten the unity of the Venezuelan Yamaha family. "Our new bulletin will help promote friendly relations and mutual understanding between us and our dealers", says the editor, "We intend to make the bulletin as informative and instrumental as possible by expanding our coverage to motorcycle

sports, sales and service campaigns, general business guide, technical tips, etc. so that it can always furnish our dealers with what they want to know for the sales promotion of Yamaha products."



## Día Campestre Yamaha!

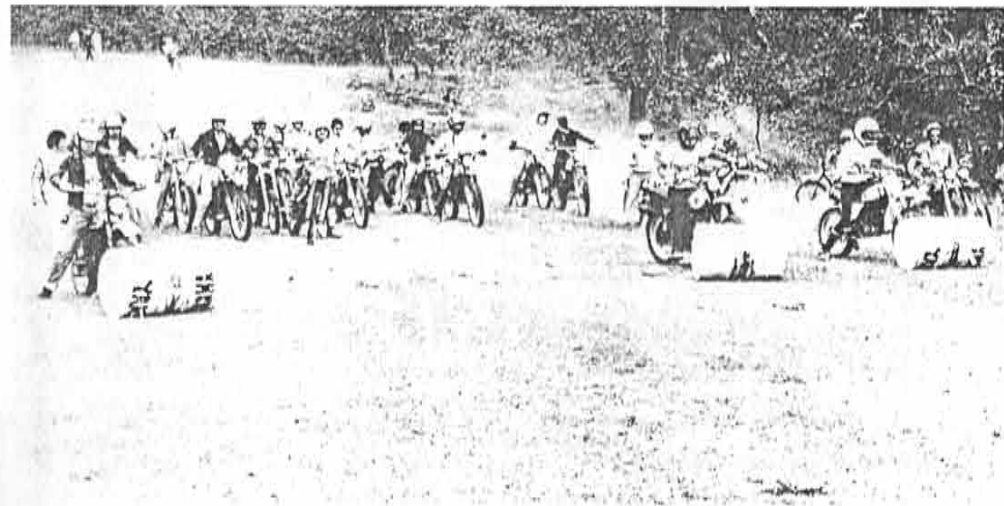

From Guatemala: Canella, S.A. which is handling Yamaha products as the general distributor in Guatemala, has recently organized a unique, large-scale sales promotion campaign called "Día Campestre Yamaha (Yamaha Field Day)".

The campaign was designed to create a favorable image for Yamaha products among the buying public, especially young motorcyclists by promoting a rich variety of delightful motorcycle games such as cask trundling, tight bridge, moto ball, the cleaner — the better, etc.

The campaign received a great deal of response from Guatemalan motorcycle enthusiasts. On the festival day about 1,200 people participated in these games. The number of bikes used was in excess of 800 (600 Yamahas and 200 others). Prizes were also prepared in abundance for these participants, including:

- \* Coupons worth \$50 each
- \* Tires (for Yamaha bikes)

- \* Helmets
- \* Yamaha purses
- \* Yamaha key holders
- \* Yamaha emblems
- \* Yamaha T-shirts
- \* Bardahl additives

The campaign was one of the most impressive and successful motorcycle events in Guatemala, creating a strong brand image for Yamaha in the motorcycle market.



# Multiplying the effect of Caravana YAMAHA

From Colombia: Incolmotos Cia., S.A., Yamaha's Colombian importer, by its close cooperation with Yamaha Motor promoted a large-scale sales, service and safety campaign in May of 1980. This campaign, the details of which were reported in our issue No. 9 of last year, covered all the major markets in Colombia where it was a great success, creating a higher sense of trust in the Yamaha brand. The Colombian motorcycle market is still growing and Yamaha's share also continues to increase. Incolmotos has a forward-looking goal of making its leadership in the market indisputable.

In connection with this, the company has recently launched a series of similar campaigns in several cities in an effort to multiply the effect of the very successful Caravana YAMAHA. In this respect, they may be called "Mini Caravana YAMAHA". The staff of the company conducted these campaigns in close cooperation with associated local Yamaha dealers as follows:

- July Armenia
- September Caucaia
- October pasto
- November Ibagué and Hilardo

Each campaign program included a reception, free check service, new model exhibitions, a lottery, BGM, sales of parts and accessories, and the Learn-To-Ride classes.

Each campaign attracted a lot of people and especially, the LTR (Escuela de Motociclismo) which could be considered as a form of before-sale service, received a great number of favorable comments.

**YAMAHA NEWS**

**Contributions wanted**

We at the Editorial Room of Yamaha News are always looking forward to having you supply us with various editorial materials so that we can make Yamaha News more instrumental to sales business. Any sort of news or information would be highly appreciated, if it is about Yamaha. Newspaper or magazine clippings will also serve to help us. Please attach some photos, colored or black-white to your news or information wherever possible.

Address: Editorial Room of Yamaha News  
Advertising & Public Relations Div.  
Overseas Markets  
Yamaha Motor Co., Ltd.  
2500 Shingai, Iwata-shi,  
Shizuoka-ken (Japan)

Tel: IWATA 05383-2-1111  
Telex: IWATA 4263 751 YAMAHA J  
Cable: YAMAHA MOTOR IWATA

## Colombian dealer meeting

Yamaha's Colombian dealers affiliated to Incolmotos recently met in Coltejer to discuss many important matters concerning Incolmotos' future sales program and policy.

As mentioned above, Incolmotos is enthusiastic about securing a position of unchallenged leadership in the always-growing Colombian motorcycle market in close cooperation with all dealers concerned. In response to this, all the dealers have promised to join forces under the Incolmotos banner to expand the market for Yamaha products.



## The oldest Yamaha fan!

From New Zealand: Mr. Oliver Cottrell, an 85-year-old gentleman of Napier, New Zealand, has recently purchased a

"I wanted something to beat the wind and go shopping", he says.

### Back on two wheels . . .

new Yamaha QT50 from Jack Burn Ltd., one of Moller Yamaha's dealers. Introduced here are the extracts of the story appearing in the Daily Telegraph: "It's a corker little job," Mr. Cottrell says, "It will be very, very handy."

Three attempts were needed before the ex-motor mechanic passed the written examination enabling him to get a provisional licence. Motorcycles are not new to Mr. Cottrell. He started riding in 1912 as a motor apprentice in Invercargill, and still has the one shilling 1918 licence..... In those days, he raced Douglas bikes on the beach and rode around on such famous names as BSA and Triumph.

The 50cc commuter bike is a big change from what he has been used to recently.....



# New Technical Center Opens in Kakegawa

From Iwata: Back in 1973, Yamaha opened the Technical Center Iwata as the nucleus of its safe driving promotion activities. At the same time the Center was authorized as the first public motorcycle school. Since then, the Center has played an important role in the promotion of traffic safety by conducting various kinds of safe driving seminars including 50 cc bike licence classes and big bike licence classes.

Enjoying the trust of all safety-minded people and organizations, Yamaha has recently expanded the program by opening a new Technical Center in Kakegawa, a local city about 20 km east of Iwata. Construction work, which started earlier in 1980, was completed on the first of Nov. Operations started on Nov. 16 prior to its official opening. A grand opening ceremony took place on December 5, thus marking another milestone in Yamaha's safe driving promotion pro-

gram. The new Center, which is called the Yamaha Technical Center, is tackling a new project of developing advanced safe driving know-how in cooperation with the Yamaha Safe Driving Promotion Center, besides conducting all sorts of safe driving promotional activities inherited from the Technical Center Iwata.

## Outline of the Yamaha Technical Center

Site Area: 13,000 m<sup>2</sup>  
 Total course area: 9,000 m<sup>2</sup> (paved course, 6,600 m<sup>2</sup>)  
 Courses: S-type, crank, intersection, tight bridge, slalom, braking, hairpin, etc.  
 School building: Two-storied (1st floor 600 m<sup>2</sup> & 2nd floor 380 m<sup>2</sup>), comprised of two classrooms, a physical examination room, scoring room, meeting room, garage, control room, etc.

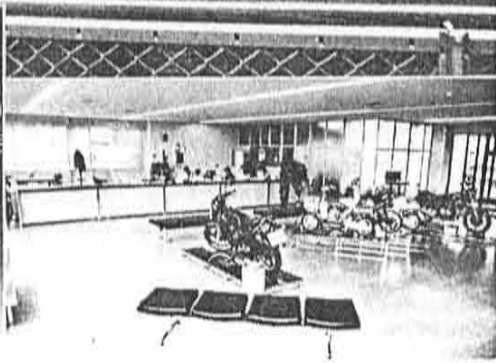
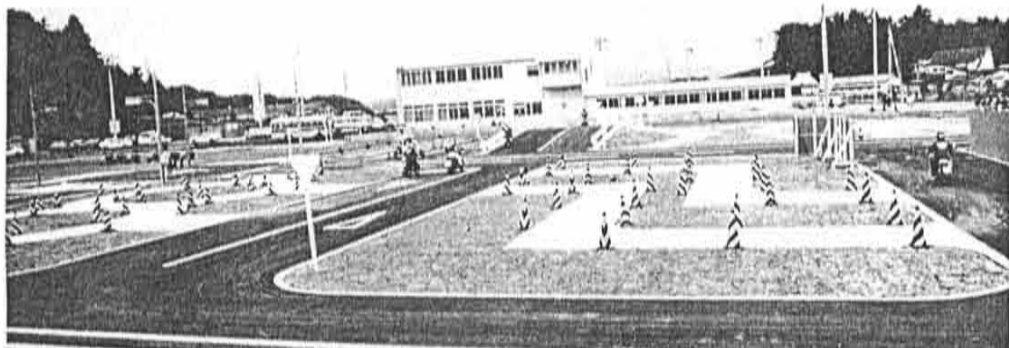

## A successful XJ650 team

From New Zealand: Introduced here are Richard Scouler (left) Peter Fleming (right) who are racing a Yamaha XJ650 on behalf of Hughson Motors, one of Moller Yamaha's dealers and with support from Moller Yamaha. The team proved to be very successful in many of the 1980 production races in New Zealand. Moller Yamaha also entered an XJ650 ridden by Trevor Discombe and Paul McLachlan in these races. In addition, there were a number of dealer entries of this model which won the prestigious "Bike of the Year" award from "Two Wheels", Australia's national monthly motorcycle magazine.



## Motorcycle Display Team



From Hong Kong: The 29th Squadron RCT Motorcycle Display Team, which is based in Hong Kong and made up of Chinese soldiers in the British arm, performs wonderful stunt displays using eight Yamaha XT bikes at various fetes, fairs, and other public events held in Hong Kong and Macau.

The team is expected to perform at the Edinburgh Military Tattoo in Scotland in August of next year. Their performances will be watched by a live audience of a quarter of a million people over a period of 3 weeks. In addition, a television audience of some 150 million will see them via the Eurovision network, which televises the Tattoo every year.



## Yamaha TZ production racers

help to promote the spread of sport enthusiasm



From Spain: Giving a strong stimulus to the growth of sport enthusiasm especially among the youth, two Yamaha TZ250 racers made their debut at the Second Criterium, a popular race event held in Barcelona. These machines were offered by Yamaha Motor N.V. to Solo Moto, Spain's leading motorcycle magazine which organized the event jointly with AGV, an Italian helmet manufacturer. The event was brought to a great success, attracting a larger number of spectators than before. Pictured here are two of the up-and-coming riders with the Yamaha TZ racers.

## How useful!

From Australia: Pictured here is Jane Lock, one of Australia's top woman golfers, aboard a Yamaha golf car. She played in the recent Dunhill Ladies Golf Classes where Yamaha golf cars were used by officials and sponsors.

Yamaha golf cars are steadily expanding their market in this part of the world for a number of their exclusive qualities including superb fuel economy, dependable brakes, smooth starting, lower engine noise, easy handling, etc.

Yamaha importers and dealers are also positive enough to seize every possible chance for the effective PR of these products.

Both players and officials admit how useful these products are for the smooth organization of a golf meeting.



# MACHINE OF THE YEAR

**THE GRAND SLAM!**  
Yamaha grasp the coveted MGN award with a clean sweep one-two-three

**YOUR TOP 25**  
Up to 250cc 251-300 Over 301

**MOTORRAD**  
New Yamaha XS 1100 Sport XS 1100 Turbo

**TWO WHEELS**  
BIKE OF THE YEAR  
Yamaha shaft drive XJ650H

A number of Yamaha models in the '80 range, which feature much of Yamaha's leading motorcycle technology, won annual motorcycle popularity contests sponsored by the following motorcycle magazines:

## Yamaha RD350LC, Overall Contest Winner!

(Extracts from Motor Cycle News, Great Britain)

The '80 "Machine of the Year" contest which was sponsored by Motor Cycle News, one of Britain's leading motorcycle journals, was brought to a truly grand finale for Yamaha.

The 2-stroke water-cooled RD350LC won this popular motorcycle contest overall. The XJ650 and the RD250LC placed second and third to complete a dramatic one-two-three Yamaha victory in the contest while these models won their respective classes as well.

Never in the long history of the contest has a single manufacturer scored such a brilliant victory.

"Over the past few years Yamaha has devoted considerable time and effort to developing a range of machines especially for Europe", said Mr. Akira Joh, managing director of Mitsui Machinery Sales, "The result was the RD water-cooled twins and the XJ650. We are greatly encouraged to have our efforts rewarded by having the win what is probably the most prestigious award of its kind in Europe".

All three Yamahas made their showroom debut in 1980 and have established themselves as the performance leaders of their respective classes.

Based on the TZ production racers, the RD350LC hits top speed at 110mph. Its superb handling enables it to tie rings round much faster superbikes.

It is still fresh in our memory that British star Charlie Williams won the 1980 Formula Two world championship using the 350LC engine in a TZ frame.

### Top 5 (overall)

1. Yamaha RD350LC
2. Yamaha XJ650
3. Yamaha RD250LC
4. Triumph Bonneville T140E
5. Suzuki GSX1100

### Up to 250cc

1. Yamaha RD250LC
2. Honda 250 Super Dream
3. Honda CB250 RS
4. Suzuki GSX 250
5. Kawasaki Z250

### 251 to 500cc

1. Yamaha RD350LC
2. Honda CX500A
3. Ducati Pantah
4. Moto Guzzi V50
5. Laverda Montjuic

### Over 501cc

1. Yamaha XJ650
2. Triumph Bonneville T140E
3. Triumph Bonneville T140ES
4. Suzuki GSX 1100
5. Honda CB900

## Yamaha Models Win Three Classes

(Extracts from Motorrad, West Germany)

Yamaha models enjoyed unmatched popularity in three different classes of the '80 motorcycle contest sponsored by "Motorrad", West Germany's leading motorcycle magazine as follows:

### Up-to 27PS category

The 4-stroke single cylinder road model, the SR500 placed top by obtaining 96,320 votes against runner-up BMW R45's 63,460.

### Chopper category.

The brand-new XV750 Special which made its debut during the '80 IFMA, won this category by obtaining 96,620 votes and the Harley-Davidson FXWG placed second with 74,379.

### Up-to 17PS category

The water-cooled RD250 obtained 131,761 votes to win this category by big margins over the Kawasaki Z250 (44,316). The RD250 attracted the largest number of votes in this popularity contest. The model is included in 17ps insurance category though its 250cc engine delivers 39ps.

In addition, the 4-stroke single cylinder XT500 and the 2-stroke RD80 ranked second respectively in enduro category and lightweight category. Furthermore, the 2-stroke RD350 placed second with the 4-stroke XJ550 third in up-to 50PS category.

It is also very important to note that the brand-new TR-1 (XV1000) ranked third in superbike class even before it appeared on the market. All in all, Yamaha proved to be the most successful make in this contest.

## Yamaha XJ650H, Bike of the Year!

(Extracts from Two Wheels, Australia)

The Yamaha XJ650H has won the prestigious "Bike of the Year" award from Two Wheels, Australia's national monthly motorcycle magazine. In this contest seven motorcycles made the final selection of potential winners, all Japanese with the exception of the three-cylinder Italian Laverda Jota, and ranging in size from Suzuki's GT200 two-stroke twin to Kawasaki's water-cooled Z1300. Contenders for the award — presented separately for road and off-road motorcycles — are chosen from machinery tested by Two Wheels over the previous year. Points are awarded on the basis of:

- Value for money.
- Performance of intended function.
- Advancement of design.
- Engineering excellence.
- Safety.
- Use of resources.

In their assessment of this year's new models, Two Wheeler testers particularly praised the new Yamaha for its combination of lightness (the bike is the lightest in its class and only marginally heavier than some 500s), shaft drive, handling excellence, sporting performance and value for money. "These factors, never previously combined in a shaft-drive motorcycle, are part of a futuristic concept", Two Wheels commented, "The XJ650 is a safe, well-balanced all-rounder which Yamaha can be justifiably proud of. If the 650 was conceived as the forerunner of a new generation of sporting motorcycles as Yamaha claims, we eagerly wait the others. We thought the XJ650 so good the model is now Two Wheels 1980 Bike of the Year. There is no higher commendation than that, and for \$2699 the Yamaha XJ650 is a top bike for a good price."

## Market trends roundup

This is a new column which is devoted to reporting the roundup of motorcycle market trends appearing in various kinds of magazines and newspapers.

### FOUR DIFFERENT CATEGORIES

Extracts from No. 414 (Dec. 1980), L'Automobile, France

The motorcycle market will be divided into four different categories in the future as follows:

- (1) Touring type
- (2) Sports type
- (3) Off-road type
- (4) Custom type (chopper type)

According to Mr. Herve Guio, sales manager of Honda France, these types have their own performance characteristics. Therefore, good selling time differs from one type to another.

Touring bikes sell well during Eastertide and then during the summer period. The market of sports bikes picks up after big races, such as Bol d'Or, Le-Mans, etc.

Off-road models enjoy an upsurge of demand during the period from Dec. 1 through Mar. 30 of the following year. This period benefits a great deal from the exciting Paris-Dacar Rally.

Custom bikes which are extra-gorgeous or sophisticated, sell good only during the period of "big touring" which begins early in summer. Manufacturers, however, can never disregard this newly-born category of purchasers (mostly in the age bracket of over 30 years) as their main French dealers report that the sales of these bikes account for about 32% of their gross sales.



### 125cc class

Japanese models available on the market are as follows:

Honda: XL125S, XR125, TL125, CM125 & CY80.

Yamaha: DT125MX, RD125, TY125 & TZ125.

Suzuki: GT125, RG125, & ER125.

Kawasaki: KE125A.

The Yamaha DT125MX is the best seller, according to the latest statistics available. Come next the Honda XL125S and the XR125. There is a notable trend that 2-stroke models are gaining on the share of 4-strokers in this category.

### Over 125cc class

Honda: 400N, CB900, CX500, XL500S, CM400T, 750K2, CX500 Custom & GL1100.

Yamaha: XT500, RD350LC, XJ650, XT250 & XS400US.

Suzuki: GS1000, GSX1100 & GSX400.

BMW: R100RT & R65.

In this category the XT500 is the long time best seller. 3,300 bikes were already sold for the first 8 months of 1980. Therefore, the XT500 is the most promising all-category best seller in France, followed by the sparkling Honda range including the 400N, the 900CB, the CX500 and the XL500S. The Kawasaki 650 also sells well but the newly marketed XJ650 will be a big threat to the Kawasaki. The popular RD350LC is expanding its own market as well. No Suzuki model is included among the top ten. Kawasaki is aiming at third spot in France though big Suzukis including the GSX1100 are still popular.



1,000 Yamaha dealers from 9 different countries get together at the Iwata city hall to celebrate the 25th anniversary.



President Koike is presented memorial gifts by each block representative. He is shaking hands with Mr. Thompson, European block representative.

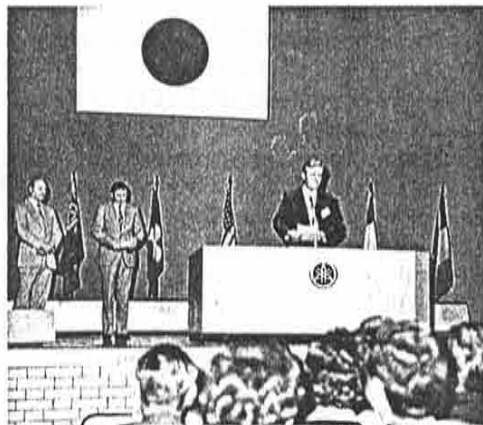

Mr. C.M.A. Meinrath representing the European block makes an address in celebration of the 25th anniversary, with Mr. W. Page and Mr. K. Severson on the left.

Mr. & Mrs. Koike, together with other Yamaha directors received all guests with a hearty clapping of hands at the entrance to the Center. Now all are seated in the hall. All lights are put out. Only a charming figure of a girl dancer in kimono costume

is spotlighted with beautiful flowers arranged in a vase on the stage. She begins to dance a graceful classic dance to a Japanese harp accompaniment. Then modern music takes the place of the

# Cooperation will be a big step toward a yearly production

## A grand dealer convention takes place in

notes of a Japanese harp and her performance becomes dynamic. Her flowing and elegant carriage is truly pleasant to see. A kuroko (black-dressed stagehand) who is in waiting behind her as the shadow follows the form, helps her change costumes one after another very dexterously .....

The ceremony opened with such a fantastic representation, and Mr. Toshiyuki Sakamoto, Manager of Overseas Operations acted as the master of proceedings. Dealer representatives holding their national flags proceeded to the stage amidst a storm of applause. Representatives were: Mr. Capiou, Belgium; Mr. M. Lawrence, Canada; Mr. W. Fischer, West Germany; Mr. Sohn, France; Mr. T. Husband, Great Britain; Mr. P. Sheaff, New Zealand; Mr. B.J. Mager, Australia; Mr. Folegger, Switzerland, and Mr. D. George, USA.

With all representatives lined on the stage, Mr. & Mrs. Koike, all Yamaha directors accompanied by their wives, directors of overseas corporations, all the key staff of related divisions and affiliated companies, staff officials of Iwata City, etc. were spotlighted one after another for introduction to all guests.

Then President Koike appeared on the stage amidst a thunderous clapping of hands. He gave an address, saying that Yamaha has grown up enormously, soon to have the capacity to produce 3 million bikes per annum, export its various products to 160 countries and have production facilities in 35 countries all over the world .....

Mr. Katsumi Yamauchi, Major of Iwata

About 1,000 Yamaha dealers from Oceania were invited to take part in a grand dealer convention at the Iwata City Culture Center on November 10, 1981, to celebrate the 25th anniversary of Yamaha Motor's founding.

## YAMAHA NEW TURBO SYSTEM



A prototype turbocharged engine which is exhibited in a hall area attracts dealers' great attention.

City, delivered a speech on behalf of all Iwata people, stating that they are proud of their city where the headquarters of world-renowned Yamaha is located.

Mr. W. Page (Oceanian block representative), Mr. C.M.A. Meinrath (European block representative) and Mr. K. Severson (North American block representative) gave an address of thanks, all emphasizing that mutual cooperation and understanding should be strengthened under Yamaha's established corporate principle.

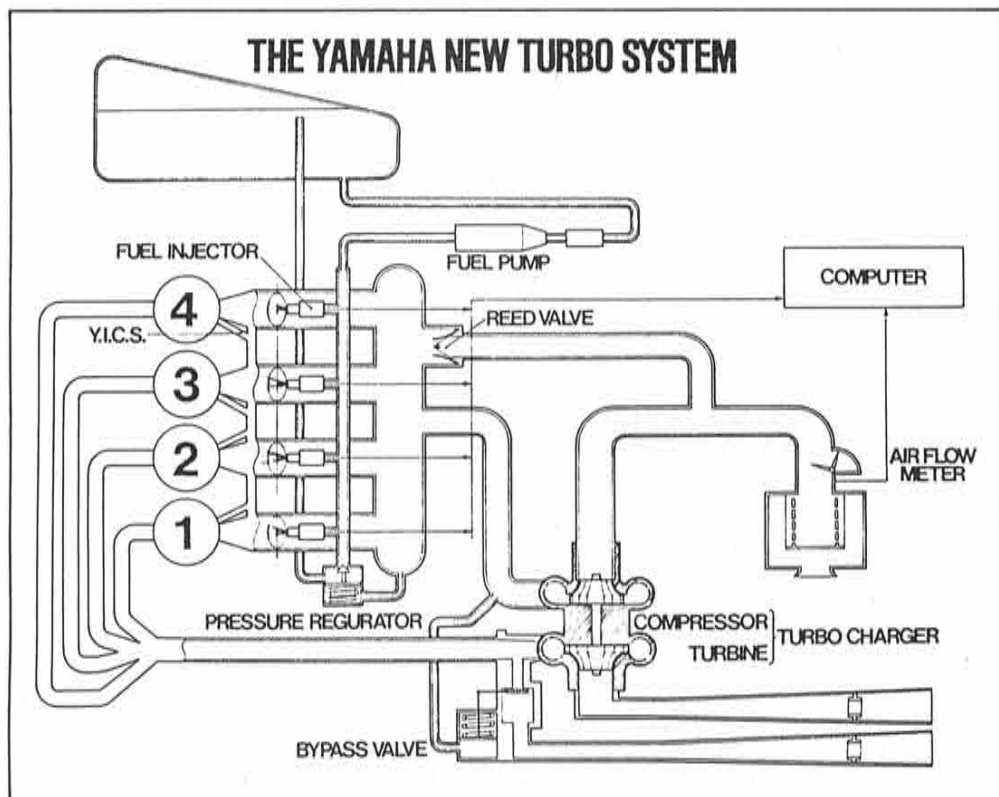

Construction of the Yamaha New Turbo System

- 1. Y.I.C.S. \_\_\_\_\_
  - 2. Reed valve \_\_\_\_\_
  - 3. Turbocharger \_\_\_\_\_
  - 4. Electronic fuel injection \_\_\_\_\_
- Integrated system

## Low fuel consumption and

# Yamaha New Turbo System

The development of the Yamaha New Turbo System is indisputably the big news attracting public attention at the beginning of 1981. The technical staff of Yamaha are striving to put this system to practical use for compact, lightweight and high performance motorcycle engines within the shortest possible period of time. It will be a revolutionary system combining the advantages of low fuel consumption and high performance.

## Low fuel consumption over a wider range of speeds

The development of the Yamaha New Turbo System created a great sensation among motorcycle journalists throughout the world when it was announced on Dec. 10 of last year.

The announcement read — "The new system features the combination of a Yamaha-original fuel-saving system, the Y.I.C.S. (Yamaha Induction Control System) and a newly developed motorcycle turbocharger, together with a unique electronic fuel injection system, in which high performance proves to be compati-

ble with low fuel consumption over a wider range of speeds.

Back in 1974, we introduced the Y.L.C.S. (Yamaha Lean Combustion System). Based on this technology, the Y.I.C.S. and the Y.E.I.S. (Yamaha Energy Induction System) have been developed and put to practical use on production models. The Yamaha New Turbo System has been completed on the basis of such proven fuel-saving technology coupled with a Yamaha-original motorcycle turbocharger and electronic fuel injection system.

The Y.I.C.S. has greatly helped to reduce fuel consumption especially over low and medium speed ranges but in the Yamaha New Turbo System, this advantage is extended to a high speed range so that fuel economy is achieved over the entire range of speeds.

Yamaha has more than ten years experience in the technical research and development of a turbocharger and electronic fuel injection systems. This dates back to July, 1970, when Yamaha developed and built a V-8 5,000cc turbocharged EFI engine for the Toyota 700, the first racing car ever built in Japan.

# Strengthened to take new business target of three million bikes!

## in celebration of the 25th anniversary

ceania, Europe and North America dealer convention which was held at December 21 of 1980 in celebration of the founding.



President Koike with Yamaha dealers posing for a camera.

### Exchange of courtesies

Mr. Koike presented a beautiful decoration plate to each block representative in commemoration of the 25th anniversary. Each block representative handed a memorial gift with words of thanks to President Koike in return. A fresh sensation aroused among all guests when a new PR film of the 25th anniversary titled "Yamaha, The Innovation Challenger" was shown on a screen on the stage. The film features Yamaha's corporate principle of bringing more convenience and pleasure to people and represents a clear picture of always-growing Yamaha in its

entire aspect as follows:

- Modern production lines
- Computerized design system
- A wide range of products such as motorcycles, snowmobiles, boats, outboards, portable generators, golf cars, etc. together with local KD plants in Thailand, Indonesia, etc.
- IPC activities
- Yamaha Power Valve System (Y.P.V.S.)
- Yamaha Energy Induction System (Y.E.I.S.)
- Yamaha Induction Control System (Y.I.C.S.)
- Exciting shots of road racing and motocross
- Rigorous tests conducted on a machine's performance, durability, strength, safety, etc.

The Yamaha New Turbo System was also featured in this film, thus causing another sensation among the guests. The convention was brought to a great success. It was attended by 1,000 people from 9 different countries as one of the largest-scale meetings ever held in Japan. "It was an excellently organized convention", said Mr. Glover, a Yamaha dealer from Great Britain, "What a wonderful experience we had today! Yamaha will continue to grow on the basis of its firm corporate policy and long proven technology and I feel it happy to be a member of the great Yamaha family". The guests moved to Tokyo on November 23 and attended the Yamaha All Together Party which was held at the Pacific Hotel, thus completing their schedule in Japan.

## Extracts from Mr. Koike's address

I am very proud that Yamaha Motor Company is able to celebrate its 25th anniversary this year.

When I recall that past years of Yamaha history, we have encountered various waves of business problems, economic crises and currency crises in Japan as well as in other part of the world. However we, Yamaha, could ride out such difficult times with a challenging, cooperative spirit and vitality with a corporate policy of creative and high-quality product development and persistent effort for the creation of a new market for our products. In the future, we shall face an unforeseeable business climate influenced by politics, economy and energy problems, however, we are very confident we will pass through such periods successfully owing to our past precious experience.

On this occasion, I would like to announce to you briefly what Yamaha is planning for the 1981 season and the future.

Firstly, thanks to the energy crisis, which influenced positively the motorcycle market, and your great efforts in the promoting of Yamaha products in your markets, our factories are, at present, running at full capacity to supply a 30% increase in orders this year,

we have committed ourselves to investing in the enlargement of our yearly production capacity to 3 million units in order to meet your demand fully and manage expected market growth.

We admit that our Four stroke model ranges haven't been superior to our competitors' in the past. But certainly you will agree with me that our last year's new models such as the XJ650, XT250 and SR250 have become very competitive, or better than those of our competitors. In addition to these newly born four stroke models, the '81 models which you have seen already at dealer meetings and motorcycle shows, will make a satisfactory contribution to your business next season. Let us say that Yamaha is always looking for ways to expand its market. However, our plans cannot be made for your diverse markets without your sincere evaluation of Yamaha products. We are helpless without your comments and ideas about sales, service, parts and financing. Give us your feedback and we can support you with a strong diverse live of dependable products. Only by working together will our efforts bear fruit.



A wooden hammer is used to open a cask. This is a time-honored practice in Japan. Managing Director Nemoto with three lady guests is showing this practice on the stage.



A grand Yamaha All Together Party at the Tokyo Pacific Hotel.



How fantastic Japanese dancing is!

## and high performance

# Turbo System

### Yamaha's unique turbo-charging system

A turbocharging system compresses the air going into the engine by means of a turbine driven by the pressure of exhaust gases. This increases the power output by charging a larger amount of air into the engine.

The system functions by utilizing exhaust energies which would otherwise be wasted, and needs no extra power to drive the turbine.

In this respect, it is as an ideal means of boosting power. The New Yamaha Turbo System incorporates a combination of already proven Yamaha technological improvement in an effort to develop the benefits of turbocharging to a maximum degree.

The reed valve induction system, for example, proves to be very useful at the time of quick acceleration or deceleration is needed by controlling the amount of air intake so that the engine provides sharp response to every throttle operation.

In addition, the new electronic fuel injection system represents. The high level of Yamaha's electronic technology, used,

Specific consideration is given to the improvement of safety factors as well by arranging the main assembly of this system in the lower space behind the engine. In this system, the advantages of individual components are integrated into one so that both fuel economy and high performance are attained at the same time, without spoiling the riding comfort inherent in a motorcycle, providing one of the best examples of Yamaha's superior integrated motorcycle technology.

### How it functions

#### At low speed

The engine continues its natural aspiration and the Y.I.C.S. functions to reduce fuel consumption without adversely affecting the driveability.

#### At high speed

The turbocharger begins to work with increased exhaust energies, thus charging a larger amount of air into the engine so that power output is increased. The fuel injection system supplies the correct amount of fuel, increasing combustion efficiency and decreasing fuel consumption per horsepower.

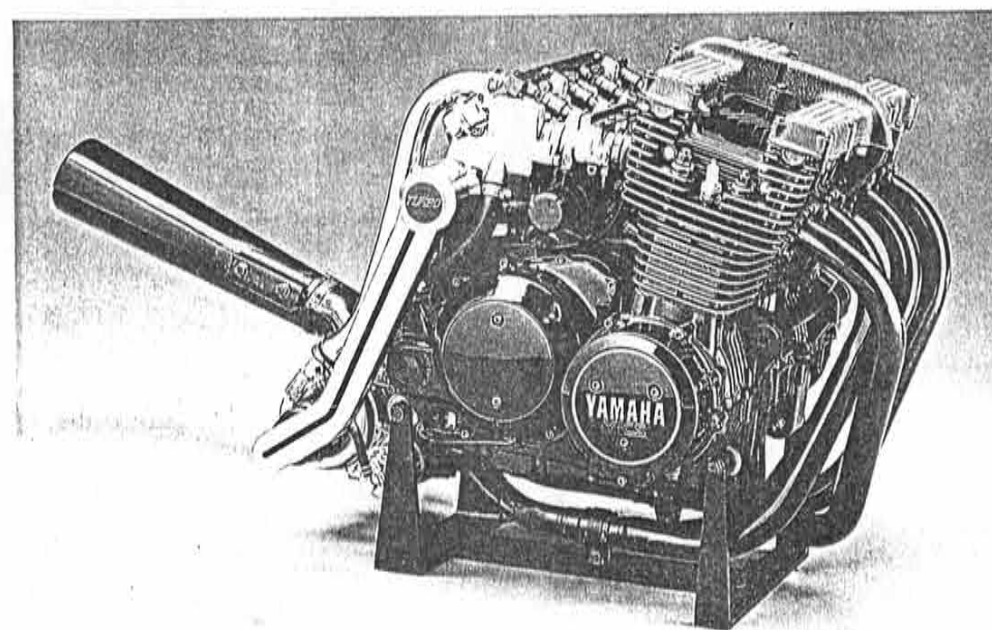

### Acceleration

The reed valve induction system increase the amount of air intake during fast acceleration so that the engine is kept highly responsive to every throttle operation, thus resulting in super-smooth turbocharging.

The Yamaha New Turbo System is designed and built, not as a conventional combination of an engine and turbocharger, but as a unique integrated system. It features the combination of the Y.I.C.S., Yamaha's renowned fuel-saving engine system, the reed valve induction system to keep the engine highly

responsive to every throttle operation, the newly developed turbocharger to ensure the smoother development of power output over the high speed range, and the electronic fuel injection system working to supply the optimum amount of fuel for a variety of different riding conditions.

The system decreases fuel consumption per horsepower by achieving maximum combustion efficiency, and represents Yamaha's positive policy to meet the needs of our resources conservation-conscious age.

## Yamaha products are finding a new market

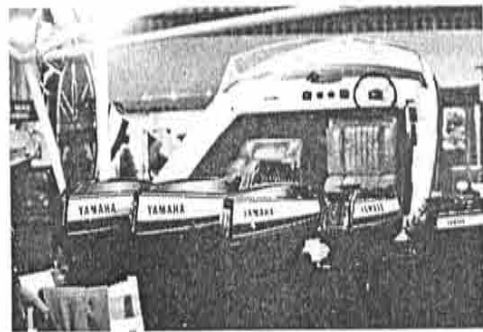

From Argentina: Astilleros Voguecraft S.A.C.I.F., Yamaha's Argentine importer with its head office located in Buenos Aires, arranged the Yamaha corner displaying the full range of Yamaha outboard motors, together with Yamaha F.R.P. powerboats and portable genera-

tors, in a very attractive manner during the international trade fair recently held in Buenos Aires.

The corner was attended by the competent sales staff of the company, who strove to make a successful approach to as many would-be customers as possible during the fair period.

This was a reflection of the company's positive policy toward the expansion of Yamaha products in the always-growing Argentine marine market where American brands are still predominant. Yamaha portable generators are also finding a good market in this country.

These products are steadily becoming popular among farmers and merchants who want to have a handy and economical source of electricity.

## Yamaha products gain popularity



Their dynamic performance adds another glamour to the event.

From Colombia: Yamaha products which were put on display during the Agrocaldas, an agriculture and fishery show recently held in La Dorado, became the talk of conversation among a number of visitors each day. The Yamaha corner was arranged by Yamaha Dorado (Sr. Arnulfo Rodriguez) and showed a wide range of quality products such as road bikes, off-road bikes, road racers and motocrossers, together with outboards and portable generators, all of which prove to be very useful for the improvement

of people's living conditions. Incolmotos, Colombian importer of Yamaha motorcycles, dispatched a motocross team to La Dorado at the request of Yamaha Dorado. The team showed off advanced motocross techniques as an attraction during the Agrocaldas, thus helping to promote the spread of motocross enthusiasm in this part of the country.



Team members with race queens



Yamaha corner with mascot girls

## A rise in Yamaha sales

Malaysia: It is something to behold that Yamaha motorcycles have continued to expand their market in Malaysia since the "Yamaha 80 Ada Kelas" campaign was successfully promoted in May of last year. The campaign has greatly helped to ele-



Fortun Motors Industries

## New Models

# Yamaha 4HP and 5HP outboards

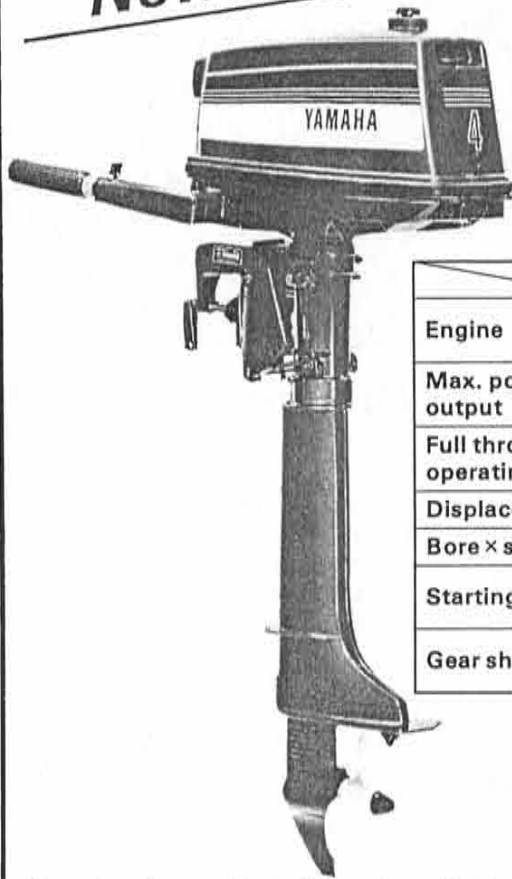

### SPECIFICATIONS

	4AC	5C, 5CS
Engine	Water-cooled 2-stroke single	Water-cooled 2-stroke single
Max. power output	4HP/5,000 rpm	5HP/5,500 rpm
Full throttle operating range	4,500 ~ 5,500 rpm	4,500 ~ 5,500 rpm
Displacement	83 cc	103 cc
Bore x stroke	50 x 42 mm	54 x 45 mm
Starting system	Recoil hand starter	Recoil hand starter
Gear shift	Forward-Neutral -Reverse	Forward-Neutral -Reverse

Yamaha has added the new single-cylinder 4HP and 5HP models to the range of small outboards with a wide variety of both customer segments and applications in recreational and commercial use. Yamaha has designed and built these models by giving specific emphasis to "better control", "simpler construction" and "easier maintenance".

Main technical improvements include the following:

- Newly designed cylinder body  
The die-cast cylinder body and head make up one unit construction and the sleeve is also cast in during the die-casting process.
- More stable performance through water cooling  
The new models feature a water-cooling system to meet the following requirements: greater reliability of the cooling system, and more stable performance even when used for many consecutive hours.

- Large capacity metal fuel tank  
A built-in type fuel tank holds 2.8 liters of fuel, the maximum in this class.
- Carburetor with built-in type fuel pump  
The carburetor and fuel pump are of unit construction. The fuel from the built-in tank is sent to the carburetor by means of the pump, making it possible to run to the last drop of fuel.
- Watertight top and bottom full cowlings  
The new models have a watertight aluminum alloy die-cast bottom cowling and F.R.P. top cowling.
- Easier fitting and carrying  
The steering handle can be turned 180 degrees for easier carrying in a vehicle. The swivel bracket has no extra projection.
- All controls grouped at the front  
All controls such as the fuel cock, choke knob, stop switch, etc. are neatly arranged at the front of the bottom cowling for easier operation.
- Maintenance-free C.D. ignition system
- Multi-location of handgrip
- Ultra-lightweight (19 kg)
- Service tools stored inside the cowling and a 12 lit. separate fuel tank (5CS)

## German international boatshow



From Germany: During a recent international boatshow held at Lake Constance, Friedrichshafen in South Germany, near Austria and Switzerland, Messrs. Wizeman & Co., the Yamaha dealer for this area showed the complete range of Yamaha outboard motors, a rich variety of Yamaha-original

marine accessories and the range of Yamaha portable generators. The new single-cylinder 4HP and 5HP models made their debut during the show. These models are designed to suit the diversified needs of fishermen, and leisure-time boatmen in this vitally important sector of the marine market.

vate the brand image of Yamaha on the market while improving and consolidating cooperative relations between Hong Leong Yamaha and all dealers concerned. Reflecting this tendency, the sales of Yamaha bikes, such as the V80 and the RX125, are constantly increasing everywhere in this country. Now all Yamaha dealers are enthusiastic about establishing "Yamaha" as the number one brand in Malaysia at the earliest possible time.



Syarikat Choong Motor



# '80 Baja 1000

## Yamaha chalks up a run-away victory

Yamaha riders on YZ-G machines swept the '80 Baja 1000, an extremely hard speed race which was recently run across the vast desert area of Baja California (Mexico). Back in 1967, the first Baja 1000 was organized as a unique car/motorcycle speed event over a 1000-mile desert course between Tijuana and Lapaz. Since then, the event has become one of the most exciting speed spectacles in the motorcycle world. But in conjunction

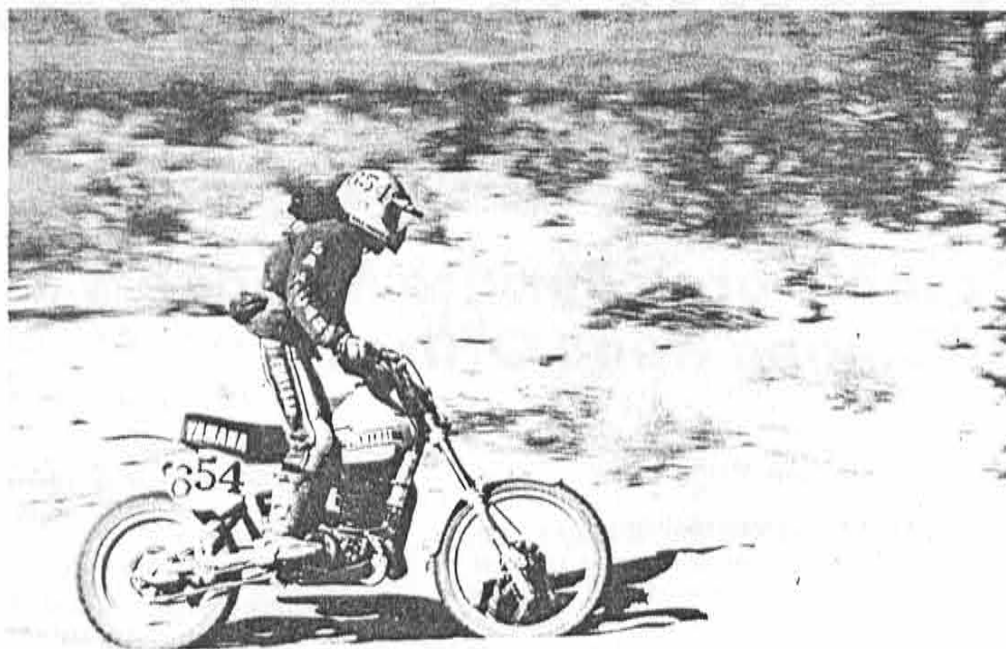

with the rapid progress of desert development, race distance has been reduced to 1,000 km from 1,000 miles in recent years. The event is open to both motorcycle riders and car drivers who compete for superiority in man's skill and machine's performance over one of the most gruelling desert courses. This year the race was held over a 1,000-km course running through the desert between Ensenada and San Felipe. Competitors had to reach the goal within 28 hours of their starting time. Motorcycle riders were grouped into the following classes:

- Open capacity
- 250 cc class
- 125 cc class
- Under 38 years old
- Over 38 years old

The motorcycle brands entered were announced as follows:

- Yamaha 24
- Husqvarna 29
- Honda 4
- KTM 2
- Can-Am 3
- Maico 1
- BMW 1

Yamaha riders rode their favorite YZ-G motocrossers in this race. Motorcycles proved to be faster than cars



in this type of competition. Especially the Yamaha machines were surprisingly tough and reliable. A Roseler/Johnson pair who started sixth, streaked into the lead at the 160 km point. From then on, they continued to widen their lead over the others and rode their Yamaha to a run-away win of the open capacity class. At the same time they were declared overall winner of the '80 Baja 1000. All other classes were also won by Yamaha riders.

## Asami rides a TZ750 to an easy win! — Macau GP

Sadao Asami (Yamaha TZ750) outclassed the others in both legs of the '80 Macau GP held on the hilly road circuit of Macau on November 15. The GP is reputed as the biggest motorcycle road race meeting in East Asia. Macau GP favorite Asami rode his big

Yamaha superbly around the 4-mile tricky road circuit between stone walls, sheer drops, etc. and allowed no challenge from the others including British Suzuki ace Steve Parrish. Asami repeated last year's success by winning both 15-lap legs very easily.

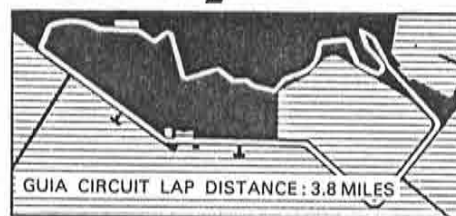

Parrish's Suzuki could not match the speed of Asami's TZ750 and his attempt of beating "Asami" ended in a failure for the second time. Parrish managed to finish second in both legs while another British rider Bernard Murray (Yamaha TZ750) counted two third places to his credit.

This made the results an exact copy of last year's first three. Dutch Yamaha rider Boet van Dulmen who was one of the pre-race favorites retired with mechanical problems in both legs.

### RESULTS

First leg	
1. S. Asami	Yamaha 750
2. S. Parrish	Suzuki 500
3. B. Murray	Yamaha 750
4. G. Vogt	Suzuki 500
5. B. Fau	Suzuki 500
Second leg	
1. S. Asami	Yamaha 750
2. S. Parrish	Suzuki 500
3. B. Murray	Yamaha 750
4. G. Vogt	Suzuki 500
5. J. Hage	Suzuki 500



### FROM '80 FIM CONGRESS

A number of important decisions were made during the '80 FIM Congress which was organized in Malta late in October. They included the following:

#### Two grands prix in Italy

Two world championship road racing grands prix will be organized in Italy in 1981. One will be the regular Italian GP and the other the San Marino GP which is to be run by Italians using their own circuit. San Marino which is a small independent state not far from Bologna, used to be represented at the FIM by Italy but recently became a separate member. This gives them voting rights in the FIM. Their application for the organization of their own GP was approved by the FIM. The race will be run at Imola on July 12 and will cater for 50, 125, and 250 cc solos and sidecars. The real Italian GP will move back to the revised Monza circuit on May 10. All solo classes will be run.

#### Argentina GP

The Argentina road racing GP will add to the world championship series in 1981 for the first time for nearly 20 years. The meeting, to be staged in Buenos Aires on March, will cater for only 125, 250 and 350 cc classes. Venezuela cancelled their GP because revision work on the new Turagua circuit will not be finished in time.

#### Turbocharged engines

Turbocharged engines will be allowed to compete in the '81 Bol d'Or 24-hour endurance

race in France so that prototypes can be tested under actual race conditions. The technical committee of the FIM will study the situation and gather sufficient data together to make definite proposals regarding capacity differentials to be imposed on turbocharged engines at the '81 FIM Congress in Japan. The FIM also decided to allow these engines to compete in all types of road racing in 1984. At the Bol d'Or 500 cc turbocharged engines are to compete with 1,000 cc naturally aspirated engines.

#### New 80 cc class

The 50 cc class, not so popular as before, will be replaced by an 80 cc class in 1984. The new class, like the 50 cc class, will be restricted to single cylinder engines and 6-speed gearboxes.

#### New capacity limits

The road racing committee of the FIM agreed to the new capacity limits for TT Formula One and Endurance races (now covered by the same regulations) from 1983 onwards as follows:

Formula One	— 750 cc 4-strokes and 550 cc 2-strokes
Formula Two	— 500 cc 4-strokes and 360 cc 2-strokes
Formula Three	— 350 cc 4-strokes and 250 cc 2-strokes
Formula Four	— 250 cc 4-strokes and 175 cc 2-strokes

New Formula Clubman — Restricted to single cylinder engines; 500 cc 4-strokes and 360 cc 2-strokes

## Growing motocross enthusiasm



125 cc class start

From Uganda: Motocross enthusiasm is rapidly growing in the Republic of Uganda, a newly-risen nation in East Africa. The nation, with a population of about 15 million, is noted for its abundant production of coffee. Lake Victoria, which bestrides the boundary between the southern part of this nation and Tanzania, is well known as the source of the Nile which runs through the continent.



Paddy Blick on a Yamaha YZ250 is in full action.

# Be No.1 with a perfect service system!

## European and Oceania area Service Managers Meeting held at Yamaha Head Offices

The annual meeting for Service Managers from the European and Oceania areas was held in November of last year at Yamaha's Head Offices. In attendance at this meeting were 15 representatives of 10 European Countries, 6 importers from 2 Oceania countries as well as a special attendance by a South African importer. During the 10 day meeting the representatives attended reports and discussions on Service Systems, service seminars on the new '81 models, and inspection tours of the manufacturing plants for related parts, making for a very significant and productive meeting.

From Iwata: This was the second meeting held in Japan in a four year period for Service Managers of the European and Oceania areas. As well as focusing on an early beginning to sales of the new '81 models, this meeting was seriously involved with the urgent business of meeting the rise in demand for quality service systems.

The main themes of this meeting were  
 1 The introduction of the 1981 Yamaha Model line  
 2 Explanations of the commercial features of the XV1000/750 and a seminar on service points for these models  
 3 Discussion of the preparation and availability of service information materials. Also as necessary such items as:  
 4 Discussion of technical aspects and servicing of the C.D.I. and T.C.I. system.  
 5 Discussions of other sub-

jects that came up such as Warranty Policies. From Yamaha such representatives as the General Manager, Mr. Takao Takahashi and Manager, Mr. Ishida of the Overseas Service Division, as well as the representative in charge of each country, in addition, Mr. Tadanori Arata, Managing Director, Mr. Tsuyoshi Konomi, Director and Chief General Manager of Overseas Operations, and Mr. Satoshi Watanabe, General Manager of Overseas Operations, in order to express their concern for the importance of service activities were in attendance for some parts of the 10 day meeting where they heard reports from each country on the present condition of service activities and extended their requests for broader and even more effective cooperation in the future in the area of service activities.

One of the highlights of the meeting was a session in which the teams of 3 or 4 representatives were each given a new model of Yamaha's new "ace" in the big machine market, the 75° V twin XV1000/750 as a practice model to break down and overhaul completely in order that they might master the new service techniques.

The following is the address given by Managing Director Mr. Tadanori Arata. "All of us at Yamaha are renewing the determination to perfect our after-sale service system as we feel ever more than before the important role that service plays in sales promotion, and we do need the assistance of your service personnel

to an ever greater degree."

The following is a list of those in attendance.

### 15 representatives from Europe

Mr. P. Olbrich (Jamoto, Austria) Mr. O. Beschorner (Jamoto, Austria) Mr. A. Vandersypen (Dieteren, Belgium) Mr. M. Jensen (S.R.I., Denmark) Mr. M. Weihe (Mitsui Iöhne, W. Germany) Mr. H. Otting (Mitsui Iöhne, W. Germany) Mr. K. Lavrentz (Mitsui Iöhne, W. Germany) Mr. H. Farey (Mitsui UK, England) Mr. P. Kibbler (Mitsui UK, England) Mr. K. Fredriksson (Arwidson, Finland) Mr. A. Rault (Sonauto, France) Mr. D. Bauche (Sonauto, France) Mr. H. Dullens (I.M.N., Holland) Mr. B. Casserborg (Hallman & Eneqvist, Sweden) Mr. O. Hostettler (Hostettler, Switzerland)

### 7 representatives from Oceania

Mr. J. Klavitter (Annand & Thompson, Australia, QLD) Mr. A. Nash (Ken-George, Australia, W.A.) Mr. T. Willis (Ken-George, Australia, W.A.) Mr. J. Testore (Mucculloch, Australia, N.S.W.) Mr. J. Paddock (Milledga, Australia, VIC) Mr. G. Pitman (Pitman, Australia, S.A) Mr. M. Elliot (Moller, New Zealand)

## FROM OUR EDITORIAL ROOM

How do you like the first issue of 1981? As you see, it is considerably renewed in format. The size is enlarged, with the number of pages decreased to 12 from 16. But we do not mean that we will stick to the same number of pages each month in the future. The number of pages will be changed from time to time, according to the quantity of news and information as we deem it necessary to cover. We hope that our new editorial method will be given your kind consent.

We are most grateful for your continued cooperation which is essential to the improvement of our Yamaha News. We are always enthusiastic about making the contents as informative and interesting as possible. Contributions including your esteemed comment or advice are cordially invited.

### Special attendance

Mr. T. Jhons (Charlie young, South Africa)



Together with a self-introduction, each representative gives a report on the present conditions of Service activities in his area.



Mr. H. Farey from Mitsui U.K. uses slides and charts to discuss the state of their Service System.

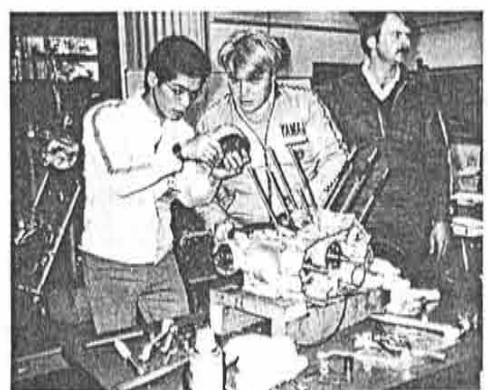

A Yamaha staff member uses an overhead projector to explain service points for 1981 new models.



Managing Director Tadanori Arata gives his address, on his right is Mr. Konomi, Director and Chief General Manager, Mr. Satoshi Watanabe, General Manager, and on his left Mr. Takao Takahashi, General Manager.



A lecture on service and repair of the important V twin.

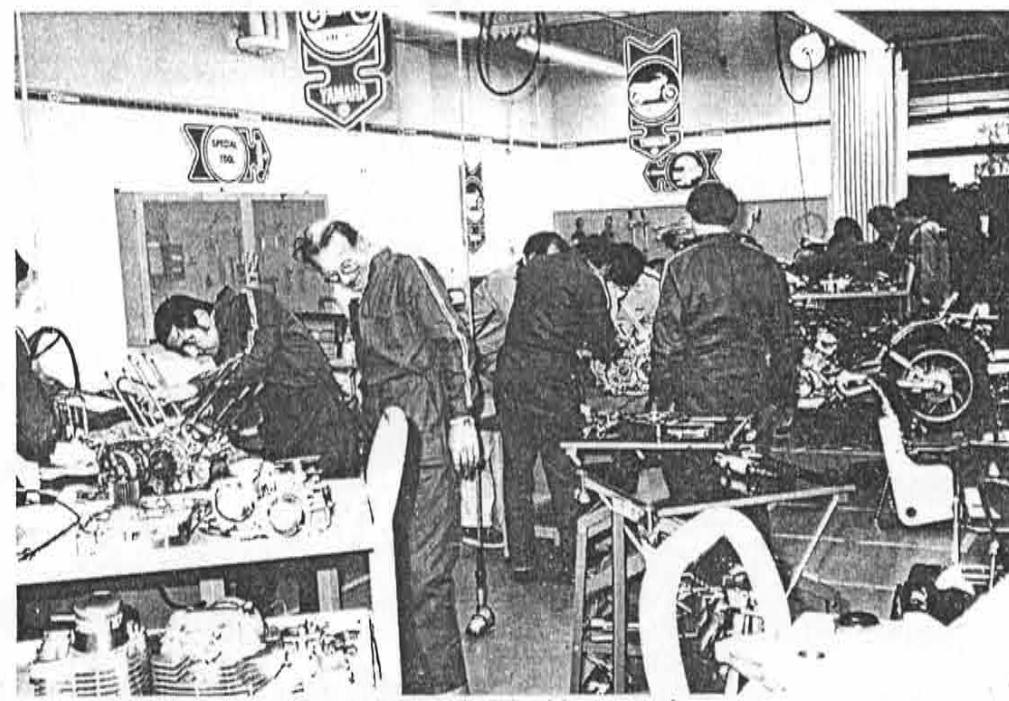

Let's start the job with teamwork.

## Dealing with an expanding market

### A Power Products Dealers Meeting is held for the first time in Indonesia

As has been mentioned time and again the expansion of the motorcycle market in Indonesia during 1980 was truly amazing. Recently a Dealer's meeting was organized by Harapan Motor to prepare for even higher goals in 1981. Also as you probably recall from our Yamaha News issue No. 5 of last year Indonesia was sighted as one of the most promising markets for power products. Now expected expansion of the Indonesian market is progressing at a marvelous rate. What is more this strong trend shows no sign of waning.

All this clearly suggests that these power products are on the way toward becoming one of Yamaha's staple items. In order to decide how to respond to this tremendous rise in demand, for the first time ever a Dealers meeting was held strictly for power products dealers. The need is growing year by year in Indonesia for products such as generators for nighttime home or construction site lighting, multi-purpose engines necessary for water transportation on large and small rivers, water pumps essential for



Presidents Koike and Hendra present panel clocks to the outstanding dealers.



Mr. & Mrs. Koike and President Hendra involved on conversation at the dinner party.



A warm handshake for one of the dealers from President Koike. In the center is Mr. Y. Sato, General Manager of Marine & Power Products Division.

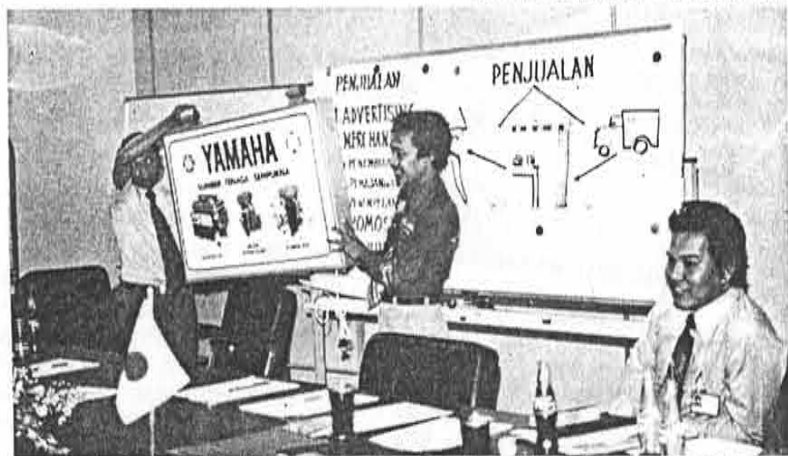

A display showing the effective use of a billboard, and repeated discussions of different aspects of sales techniques for the future.

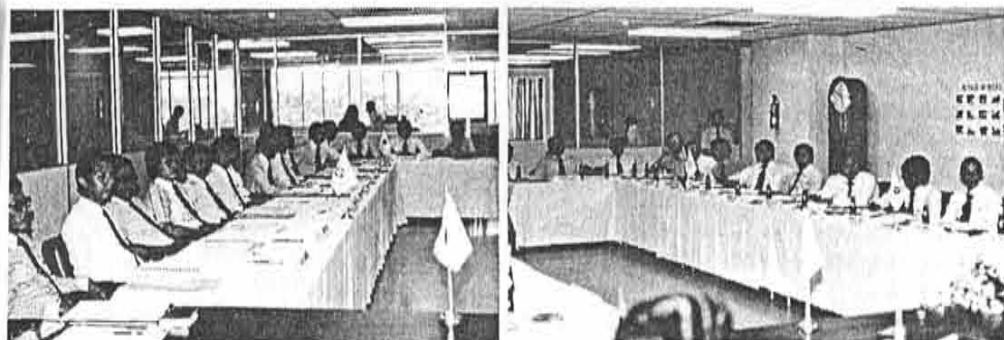

Intense discussions go on at the Power Products Dealers Meeting in the Conference room of Harapan Motor's Head Offices.

agriculture and irrigation and the like. As a result of this trend P.T. Adiasa Sakti, a member of the Harapan group, was appointed head of a new division for power products. On December 5th and 6th the first Dealers meeting to deal strictly with power products was organized by P.T. Adiasa Sakti. It turned out to be a very active two-day meeting attended by such notables as Yamaha's President Koike, Mr. Hendra, President of Harapan group, Mrs. Cheong Swee Kheng and Mr. Lo, both directors of P.T. Adiasa Sakti, Mr. Gani, General Manager and Mr. Frans, Manager. The 21 dealers who gathered on the fourth floor of the Harapan Building listened intently to the explanation from Harapan as well as actively exchanging questions of their own. The purpose of this dealers meeting was, in response to the rapidly growing demand, to educate the dealers in sales promotion on a level fitting a true sales leader; in other words, to make the dealers knowledge of the various products more accurate and more detailed, and at the same time to discuss contemporary sales techniques as well as attempting to find techniques suited to the needs of a particular market. In addition to these types of dealer training, they strove to set their sales targets, show the sales leaders in each territory and analyse the reasons for their success, and all in all to

set concrete plans for the coming year. There were also displays of the continually high demand generator models (ET500, EF/1500, 1800, 2000, 2600 etc.) and the multi-purpose engine models (MT110A/AR/VL, MF150A, 180A/AR, MF260A/AR, F) also the YP20G and YP30G model water pumps. Along with the displays were charts giving explanations, detailed examples of different uses, and how to repair the different products. At the same time the new water pump and generator models YP20G, YP30G, EF2000 and 2800 were introduced. President Koike of Yamaha, who was in attendance for one day of the two day meeting, presented all the 21 dealers with a gift panel clock, and to the 9 dealers out of the 21 who's sales made up 75% of the total, he presented a shield. It was also stated that the 8 dealers with the best sales records in the coming year would be invited on a 10 day tour of Japan. At the dinner party held for President Koike, Harapan and P. T. Adiasa Sakti and their representatives along with the 21 dealers on the night prior to the Dealers Meeting, there was plenty of celebrating as well as serious talk centered around the forecast of continued growth in the demand for power products in Indonesia. It was decided by all that the Dealers Meeting would become a yearly event.

# SAFE RIDING AND PSYCHOLOGY

"What is 'Safe Riding'?"  
 If asked this question, there are probably few people who could answer immediately and with complete confidence.  
 "Handling a vehicle skillfully."  
 "Keeping all the rules of the road."  
 "Never letting your attention stray."  
 "Correctly reading each traffic situation."  
 "Making correct judgements and quick decisions."  
 All of these are important elements, but real "Safe Riding" comes from the ability to control each situation through the proper synthesis of all these important elements. If we take a look at the way we make judgements of situations as just one example, we will see that such internal factors as one's way of thinking or way of looking at things, what things one is interested in, one's personality, the things one wants, all have a strong effect on one's judgements as a driver. The act of driving a vehicle safely is quite a complicated matter. With this in mind, beginning with this issue, we at Yamaha, who's business is so strongly connected with traffic safety, would like to share with you a series of articles on this subject. The articles in this column will take their contents from the Yamaha Safe Riding Promotion Center's publication "Safe Riding and Basic Psychology".

this column) It's a nude, isn't it. If you look now in sequence from A to B to C etc., when you get to the original drawing E, you can still see a nude in it, can't you. Those who saw the nude at first please look at drawing H. It is a man's face, isn't it. When you look back in sequence H, G, F, and reach drawing E you can still see a man's face, can't you.

★ If you have a preconception, it will change the way you see things.

The majority of people saw a nude in the drawing first will continue to see a nude as they look from drawing A all the way to drawing H. In the same way, people who first saw a man's face will continue to see only a man's face as they look from drawing H all the way to drawing A. If you hold a preconception, you will always be subject to misconception. When you see the drawing as a young lady, the image of the old woman disappears. If you think you see an old woman you will not see the young lady. In short, when you take one view point another view point is obscured.

## 2. The world you see and the world others see.

★ What does it look like now?

Look at this drawing. It is a woman's face, isn't it. What is the lady's age? What? Is it a high class lady in her 20's. Wrong? You say it looks like an old witch! We have a problem here. How can we have such different views? Well, shall I give you the answer? Both views are correct. Look. When we hide the old woman's eyes and mouth, it looks more like the profile of a young lady. Now let's hide the young lady's eyelashes and her cute nose. Look! Now it's a hook-nosed old woman.



★ When you look at something in one way, another way of looking at it disappears.

From this you can see that the same drawing, depending on who is looking at it may look like an old woman or a young lady. It is not that the picture is changed, the image that reaches your retina has not changed. In spite of this, however, the way we see things, and also what reaches our attention does change.

This is an example of the fact that often what you think you are seeing can also be seen in other completely different ways.

★ While driving, in order to be sure that are not mistaking one thing for another it is important to always be objective and cool headed.

★ What you see is not always what actually exists.

We usually tend to think that the way we see things, or experience things, is the way they are. The things we see (our subjective world) we tend to think of as the way things actually are (the objective world).

However, as we have seen, that is not always so.

Perhaps now we all understand that "Seeing" is not simply a phenomenon of the retina and nerves.

We see with our "minds". The eye simply serves the role of a lens for the "mind".

## Part 1 Are you "seeing correctly" when you drive?

If you were to describe it simply, the job of driving vehicle is a constant repetition of the process of "recognition" → "judgement" → "action". The eyes and ears must quickly read the situation, from this information the mind must immediately make a judgement and finally the proper action must be taken. The continuous repetition of this process is the way we drive a vehicle on the road. Reading the surrounding situation is the job of the sense organs, and in the case of driving a vehicle 80% of the sense information involved is visual information. About one half of all traffic accidents are results of a visual mistake. These consist of lack of recognition, mistaken recognition, or delayed recognition. It can be said without exaggeration "seeing correctly" is the most important single element in safe driving. Now comes the question of what is "seeing correctly" with regards to driving a two-wheeled vehicle safely? Let's explore this important question together.

Here is a drawing. What is this a drawing of? Look carefully please.



### 1. "Mistaking one thing for another". The same object can be seen in many different ways.

★ Well, what does this look like?

Is it a man's face? Is it a nude portrait of a young woman? Most young men answer that it is a nude, while most children and women answer that it is a man's face. Both views are correct.

Those of you who saw a man's face, please look at drawing A. (Shown at the bottom of

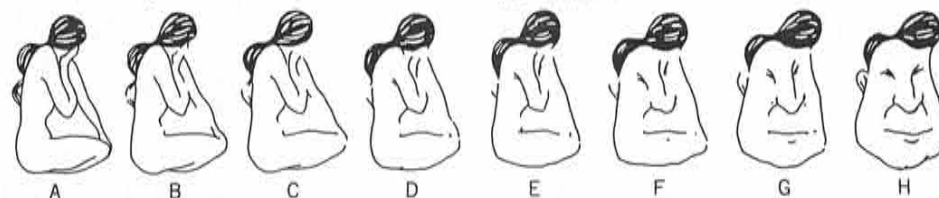



# "AT SPEED" & "An Exciting Start" Will Bring the Vivid Excitement of '80 World Championship Road Racing & Motocross

The two new race films which we have recently produced for worldwide distribution, recreate the vivid sensation & excitement of the '80 world championship road racing and motocross with Yamaha stars in the heat of competition. One is titled "AT SPEED" which follows the exciting highlight scenes of the fierce 500cc title battle where "King" Kenny accomplished a brilliant hat trick by beating Randy Mamola (Suzuki), his strongest rival. The other is titled "An Exciting Start" which brings vivid how Yamaha stars fought in the 125cc and 500cc world championship motocross series of 1980. As you know, films are one of the most effective sales promotion aids. Especially, sports films never fail to create a fresh sensation or interest each time they are shown.

They will serve as a very effective tool in your approach to would-be customers while they will help to improve the brand image of Yamaha, if you use them, for instance, on the following occasions:

- Dealers meeting
- Service seminar
- Clubmen's meeting
- Licence or safe driving school
- Various sport events
- Visit to would-be customers

### Specifications

Title: AT SPEED  
 Size (width): 16 mm  
 Running time: 34 minutes  
 Length: 372 m  
 Narration: English, Spanish, French, German or Chinese  
 Price: ¥ 60,000 FOB Japan

Title: AN EXCITING START  
 Size (width): 16 mm  
 Running time: 30 minutes  
 Length: 330 m  
 Narration: English, Spanish, French, Germany or Chinese  
 Price: ¥ 60,000 FOB Japan



### Summary of the films

• **AT SPEED (Road racing)**  
 The Italian GP, which took place on the circuit of Santa Monica on May 11, became the virtual curtain raiser of the 8-

round 500cc world championship series as the Venezuelan GP (March 23) was cancelled and the Austrian GP (April 27) was not organized due to a heavy snowfall. American superstar Kenny Roberts who

was enthusiastic about clinching the 500cc crown for the third consecutive year, rode a Yamaha YZR500 to a convincing win after a fierce first-stage battle with Italian Suzuki ace Marco Lucchinelli who had clocked the fastest practice time the previous day. That was a superb start in the '80 title chase.

"King" Kenny repeated his success in the Spanish GP at Jarama on May 18 and counted the third win of the year to his credit in the French GP at Paul Ricard on May 25.

The film follows the development of a white-hot title battle between Kenny and Randy Mamola until Kenny clinches his third crown in the West German GP, the final round of the series.

### • AN EXCITING START (Motocross) — Four Lions —

Yamaha motocross riders fought their way on under the Yamaha banner! Hakan Carlqvist (Sweden) and Andre Vromans (Belgium), both GP stars, chalked up a number of wins in the 500cc series. Up-and-coming Tetsumi Mitsuyasu (Japan) and Marc Velkeneers (Belgium) did it well in the 125cc series. They are the four lions selected by Heikki Mikkola, Yamaha's superstar who won the 500cc world championship title in 1977 and 1978.

The film follows how these riders and Yamaha YZM machines performed in the '80 world championship motocross series. Introduced in this film are the highlight scenes of the following grands prix:

- 125cc Yugoslavian GP
- 125cc West German GP
- 125cc Finnish GP
- 125cc Spanish GP
- 500cc Dutch GP
- 500cc West German GP
- Belgian sidecar cross counting toward the world championship

## Yamaha Towny commercial is awarded Grand Prize

From Iwata: A bike which has been left by the roadside attracts a labourer's attention. He looks greatly interested in the bike and begins to inspect it carefully. The bike owner appears on the scene with a smile. The following words pass between them:  
 "Is this yours?" "Yes, it is mine."  
 "What a nice one!" "Right!"  
 Then the bike owner rides off, leaving the labourer alone. He mutters to himself with a sigh of admiration — "What a nice one!"

This is an outline of a Yamaha Towny commercial recently televised all over Japan. The bike owner is played by Mr. Sadao Watanabe, one of Japan's most popular jazzmen, nicknamed "Nabe Sada". The labourer is played by amateur

who really works as a labourer. The commercial has achieved a tremendous PR success, thanks to his unsophisticated

performance coupled with Mr. Watanabe's agreeable character. Mr. Watanabe was introduced in No. 5

issue of 1980. "Is this yours?" and "What a nice one!" — these words have already become catchphrases.

The commercial was awarded a Grand Prize and Special Prize in the 20th Commercials Festival recently organized by the All Japan Commercials Council (ACC).

The Yamaha 50cc series which includes the above model has already made up the largest share of the 50cc market in Japan. In the 20th commercials festival 2,810 works were judged for their originality and content as well as PR effect.



The All Japan Commercials Festival



Yamaha Towny commercials are awarded an ACC Grand Prize and Special Prize. Mr. Ishida, Assistant General Manager of the AD Div. (center) and the staff.

