

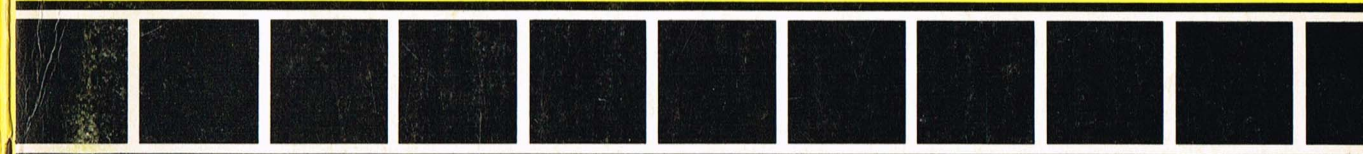

YAMAHA

YZ125E

OWNER'S SERVICE MANUAL



LIT-11626-00-99

IMPORTANT NOTICE

This model is designed for motocross competition only. It is illegal to operate this vehicle on any public street, road, or highway. Know your local laws and regulations before operating this vehicle.

Particularly important information is distinguished in this manual by the following notations:

NOTE:

A NOTE provides key information to make procedures easier or clearer.

CAUTION:

A CAUTION indicates special procedures that must be followed to avoid damage to the machine.

WARNING:

A WARNING indicates special procedures that must be followed to avoid injury to a machine operator or person inspecting or repairing the machine.

**YZ125E OWNER'S SERVICE MANUAL
FIRST EDITION SEPTEMBER 1977
SECOND EDITION AUGUST 1978
ALL RIGHTS RESERVED
BY YAMAHA MOTOR COMPANY
LIT-11626-00-99**

INTRODUCTION

Congratulations on your purchase of the Yamaha YZ125E. This model represents the product of many years of Yamaha experience in the production of fine sporting, touring, and pace-setting racing machines. You can now appreciate the high degrees of craftsmanship and reliability that have made Yamaha a leader in these fields.

PLEASE READ THIS MANUAL CAREFULLY AND COMPLETELY BEFORE OPERATING YOUR NEW MACHINE. This manual will provide you with a good basic understanding of the features, operation, and basic maintenance and inspection items of this vehicle. If you have any questions regarding the operation or maintenance of your machine, please consult your Yamaha dealer.

NOTICE:

Some data in this manual may become outdated due to improvements made to this model in the future. If there is any question you have regarding this manual or your machine, please consult your Yamaha dealer.

SERVICE DEPT
INTERNATIONAL DIVISION
YAMAHA MOTOR COMPANY, LTD.

CONTENTS

MACHINE IDENTIFICATION	1
CONTROL FUNCTIONS	2
PRE-OPERATION CHECKS	6
PERIODIC MAINTENANCE	9
ADJUSTMENT AND MAINTENANCE	15
MINOR REPAIRS	37
SPECIFICATIONS	69
CLEANING AND STORAGE	79
WARRANTY INFORMATION	81

MACHINE IDENTIFICATION

Frame serial number

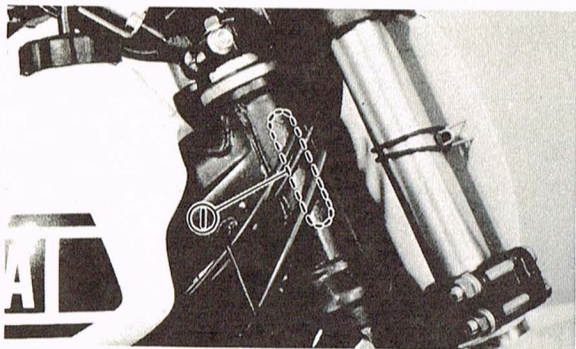

1. Frame serial number

Engine serial number

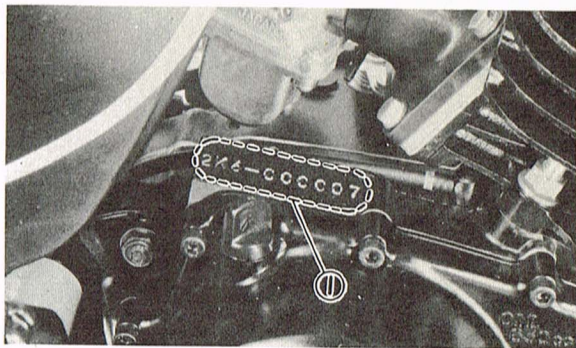

1. Engine serial number

NOTE:

The first three digits of these numbers are for model identifications; the remaining digits are the unit production number. The engine and frame serial numbers are usually identical.

CONTROL FUNCTIONS

CAUTION:

Before riding this motorcycle, become thoroughly familiar with all operating controls and their function. Consult your Yamaha dealer regarding any control or function you do not thoroughly understand.

WARNING:

This model is not equipped with highway approved lighting. This model is designed solely for competition use and should not be used on a street or highway at any time. In most instances, it is illegal to ride this model on any public street or highway.

Clutch lever

Front brake lever

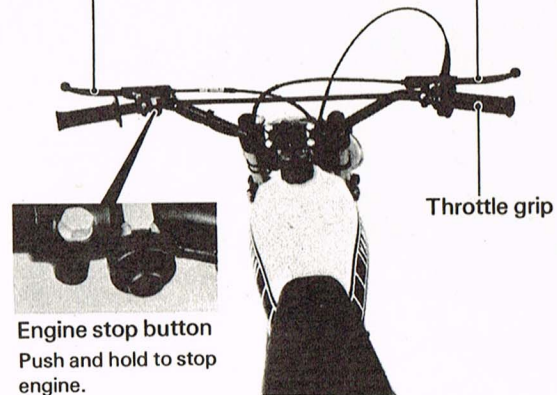

Throttle grip

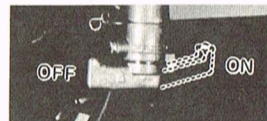

Forward "ON"
Backward "OFF"

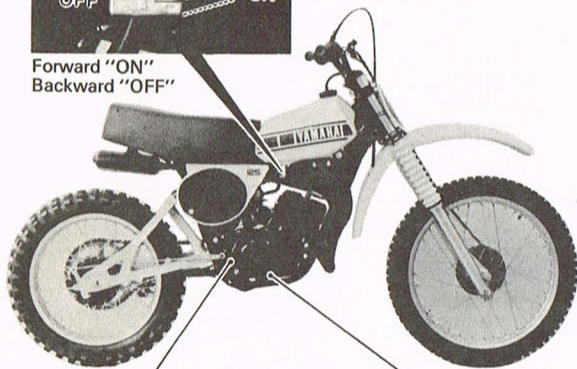

Kick
Crank
Primary kick starter system

Rear
brake pedal

Starter jet lever

For starting a cold engine, push lever down to open the jet and kick the kick crank briskly to start the engine.

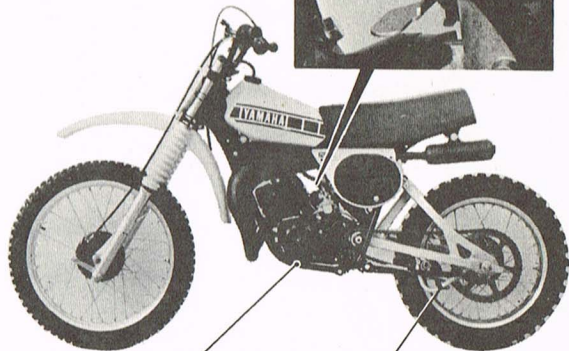

Shift pedal
Ratcheting type 6-speed
transmission

Chain tensioner

Fuel

Use premium gasoline with an octane rating of 90+ mixed with oil at a gas/oil ratio of 20 : 1. Always use fresh, name-brand gasoline. Always mix a fresh batch of fuel the morning of the race and do not retain a mixed batch overnight.

Fuel tank capacity: 5.8 lit (5.5 US. qt)

Lee Waldie Craig Scott Chris Koira

Engine mixing oil

Recommended oil: Yamalube "R"
(Yamalube Racing 2-cycle oil)

Check the container top or label for service specification and mixing ratios.

Transmission oil

Recommended oil:
Yamalube 4-cycle oil or SAE 10W/30
"SE" motor oil

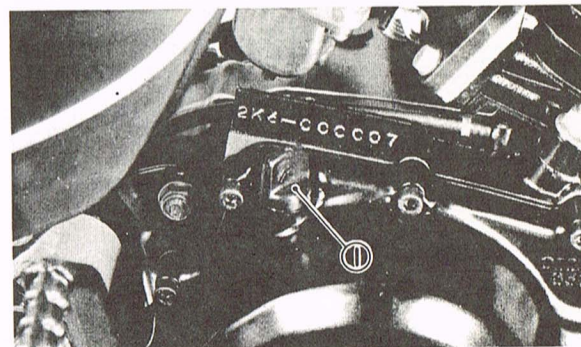

1. Filler plug

Transmission oil capacity:
Periodic oil change: 600 ~ 700 cc
(36.6 ~ 42.7 cu. in)
Overhaul: 700 ~ 800 cc
(42.7 ~ 48.8 cu. in)

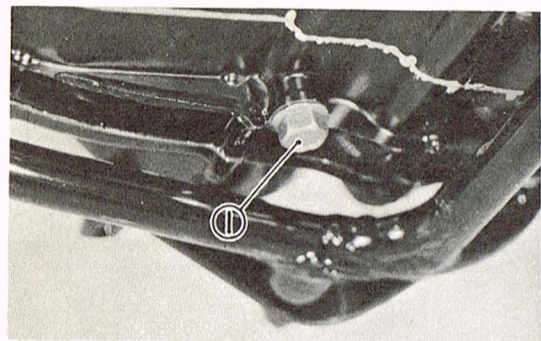

1. Drain plug

OIL LEVEL CHECK

To check, warm up the engine for 2 ~ 3 minutes. Place the motor-cycle upright and remove the oil level checking screw. If oil flows out, the oil level is correct. The transmission oil should be drained and refilled every second race meet.

NOTE: _____
Do not add any chemical additives. Transmission oil also lubricates the clutch and additives could cause the clutch to slip.



1. Checking screw

PRE-OPERATION CHECKS

Before using this motorcycle please check the following points:

Item	Procedure	Page
Brake (Front & Rear)	Check operation/adjustment	23 ~ 25
Clutch	Check operation/adjustment	22, 23
Fuel tank	Fill with proper fuel/oil mix	4
Transmission	Check oil level/top-up as required	4, 5
Drive chain	Check alignment/free play/adjustment/lubrication	25, 26
Throttle	Check for proper cable operation	16
Wheels & tires	Check pressure/runout/spoke tightness/axle nuts	—
Fittings/fasteners	Check all/tighten as necessary	—

NOTE: _____
Pre-operation checks should be made each time the machine is used. Such an inspection can be thoroughly accomplished in a very short time and the added safety it assures is more than worth the time involved.

STARTING AND OPERATION

CAUTION:

Prior to operating the machine, perform steps listed in pre-operation check list.

Starting a cold engine

Shift transmission into "NEUTRAL". Turn the fuel petcock to "ON" and operate the starter jet and completely close the throttle grip. Engage the kick starter and start the engine.

Warm-up

Run the engine at idle or slightly higher using the starter jet as required until the engine is warm. This procedure normally takes 1 to 2 minutes. To check, see if the engine responds normally to throttle with starter jet off.

CAUTION:

Do not operate engine for extended warm-up periods.

Starting with engine warm

Do not engage starter jet. Open throttle slightly. Engage the kick starter and start the engine.

NOTE:

Observe break-in procedures for initial operation.

Break-in procedures

1. Prior to starting, fill tank with a break-in gasoline/oil mixture of 15 : 1.
2. After fueling and pre-operational checks have been made, refer to "Starting and Operation" and start engine.
3. Allow engine to warm up. Check engine idle speed. Check operating controls and "Engine stop" button operation.

4. Operate machine in lower gears at moderate throttle settings for 3 ~ 5 minutes. Check spark plug condition. Spark plug will show rich condition during break-in.
5. Allow engine to cool. Repeat procedure, running for 5 minutes. Very briefly, shift to higher gears (5th or 6th) and check full throttle response. Check spark plug condition.
6. Allow engine to cool. Repeat procedure, running for 5 minutes. Full throttle and higher gears may be used, but avoid sustained full throttle operation. Check spark plug condition.
7. Allow engine to cool. Remove top end and inspect. Remove "high" spots on piston with No. 600 grit, wet sandpaper. Clean, and carefully reassemble.
8. Remove break-in fuel/oil mixture from tank. Refill with 20 : 1 operation fuel/oil mixture. Check entire unit for loose or mis-adjusted fittings/controls/fasteners.
9. Re-start engine and check through entire-operating range thoroughly. Stop. Check spark plug condition. Re-start. After 10 ~ 15 minutes operation, machine is ready to race.

PERIODIC MAINTENANCE

The maintenance and lubrication schedule chart should be considered strictly as a guide to general maintenance and lubrication intervals. You must take into consideration that weather, terrain, geographical locations, and a variety of individual uses all tend to demand that each owner alter this time schedule to match his environment. For example, if the

motorcycle is continually operated in an area of high humidity then all parts must be lubricated much more frequently than shown on the chart to avoid rust and damage. If you are in doubt as to how closely you can follow these time recommendations, check with the Yamaha dealer in your area.

MAINTENANCE AND LUBRICATION SCHEDULE CHART

Item	Recommended lubricant (By type *)	Every heat (moto)	Every meet	Every second	Every third	Every fifth	As required
PISTON Inspect Clean Replace			○ ○		○		
PISTON RINGS Replace				○			
CYLINDER HEAD Inspect (Compression) Clean Replace Check head nut torque			○ ○ ○				○
CYLINDER Inspect Clean Replace Check cylinder nut			○ ○ ○				○
CLUTCH Adjust Inspect Replace	#3		○		○		○
TRANSMISSION Change oil Inspect (gears and shift fork) Replace bearing	#1			○		(○) ○	○

Item	Recommended lubricant (By type *)	Every heat (moto)	Every meet	Every second	Every third	Every fifth	As required
ENGINE MAIN BEARING Replace						○	
CONNECTING ROD Inspect bearings Replace						○	○
PISTON PIN Inspect Replace			○				○
ROTOR NUT Torque							○(E/G O-verhaul)
KICK STARTER Inspect idle gear replace							○ ○
EXHAUST SYSTEM Inspect Clean		○				○	
CARBURETOR Check/Adjust/Tighten Clean			○ ○				
AIR FILTER Clean and oil Replace	#4	(○)	○				○

Item	Recommended lubricant (By type *)	Every heat (moto)	Every meet	Every second	Every third	Every fifth	As required
SPARK PLUG Replace Inspect		○					○
DRIVE CHAIN Clean/Lubricate Check tension and alignment Replace	#2	○ ○			○		
FRAME Clean/Inspect			○				
FUEL TANK AND PETCOCK Clean			○				
FRONT FORKS Drain and refill Replace seals Check air pressure	#5		○		○		○
REAR SHOCK ABSORBER Inspect Adjust			○ ○				
STEERING HEAD Inspect Clean/Lubricate Replace	#3			○	○		○
SWING ARM Inspect Lubricate Replace guide roller	#3		○ ○	○			

Item	Recommended lubricant (By type *)	Every heat (moto)	Every meet	Every second	Every third	Every fifth	As required
BRAKE Clean/Inspect/adjust Replace			○				○
WHEELS AND TIRES Check pressure Check runout Check spoke tension Check bearings Replace bearings		○	○ ○ ○				○
CONTROL CABLES Routing (Connection) Inspect Lubricate			○ ○ ○				
CLUTCH AND BRAKE PIVOT Lubricate Retighten	#3	○	○				

RECOMMENDED LUBRICANT

No. 1 Use Yamalube 4-cycle oil or SAE 10W/30 "SE" motor oil.

No. 2 a. Use YAMAHA CHAIN/CABLE LUBE

b. Use SAE 10W/30 motor oil. (If desired, specialty type lubricants of quality manufacture may be used.)

No. 3 Medium-weight wheel bearing grease of quality manufacture (preferable water-proof.)

No. 4 Air filter: Foam element air filter must be damp with oil at all times to function properly. Clean and lube every meet. In hard usage, clean and lube every heat (MOTO). Do not over-oil. Use SAE 10W/30 motor oil.

No. 5 Use SAE 10W/20.

SPECIAL TOOLS

No.	Part name	Part No.
1	Crankshaft setting pot	90890-01012
2	Crankshaft setting tool	90890-01017
3	Spacer	90890-01016
4	Clutch holding tool	90890-01022
5	Crankcase separagint tool	90890-01135

No.	Part name	Part No.
6	Dial gauge	90890-03002
7	Dial gauge stand	90890-01195
8	Dial gauge needle	90890-03042

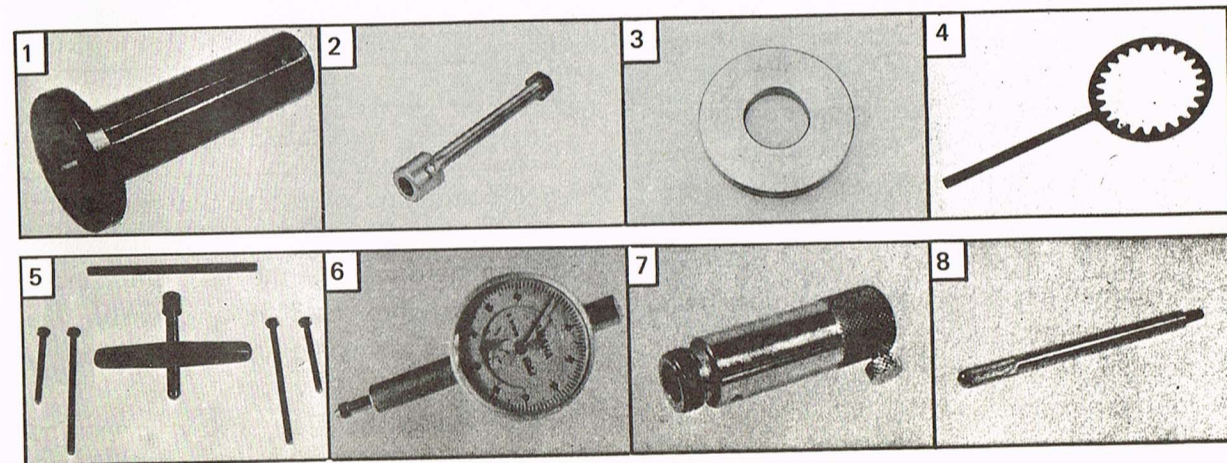

ADJUSTMENTS AND MAINTENANCE

Spark plug

The spark plug in your machine indicates how the engine is operating. If the engine is operating correctly, and the machine is being ridden correctly, then the tip of the white insulator around the center electrode of the spark plug will be a medium to light tan color. If the porcelain is a very dark brown or black color, then a plug with a hotter heat range may be required.

This situation is quite common during the engine break-in period. However, use the standard plug. If the insulator tip shows a very light tan or white color or is actually pure white or if the electrodes show signs of melting, then a spark plug with a colder heat range is required.

Remember, the insulator must be a medium-to-light tan color. If it is not, check carburetion, timing, and ignition adjustments.

If the situation persists, consult your Authorized Yamaha Dealer.

Do not attempt to experiment with different heat range spark plugs. This takes an experienced eye, to gauge the proper spark plug heat range to use and to determine if the spark plug itself is at fault.

For normal operation use:
N59G/Champion

Spark plug gap:
0.7 mm (0.028 in)

Engine conditions will cause any spark plug to slowly break down and erode. If erosion begins to increase, or if the electrodes finally become too worn, or if for any reason you believe the spark plug is not functioning correctly, replace it.

When installing the plug, always clean the

gasket surface, use a new gasket, wipe off any grime that might be present on the surface of the spark plug, and torque the spark plug properly.

Spark plug torque:
2.5 m-kG (18 ft-lb)

The spark plug must be removed and checked prior to using the machine. Check electrode wear, insulator color, and electrode gap.

CARBURETOR

Throttle cable adjustment:

Check play in turning direction of throttle grip. The play should be 3 ~ 5 mm (0.12 ~ 0.2 in) at grip flange, loosen the lock nut and turn the wire adjuster to make the necessary adjustment. Tighten the adjuster lock nut.

Lee Waldie Craig Scott Chris Koira

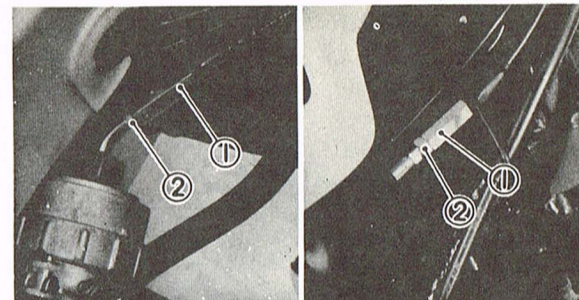

1. Adjuster 2. Lock nut

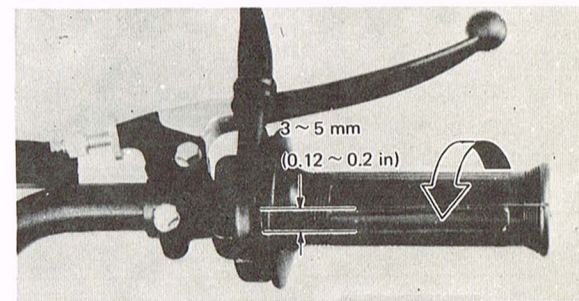

Idle speed adjustments:

1. Turn pilot air screw in until lightly seated.
2. Back out 1-3/4 turns. Start the engine and warm it up.

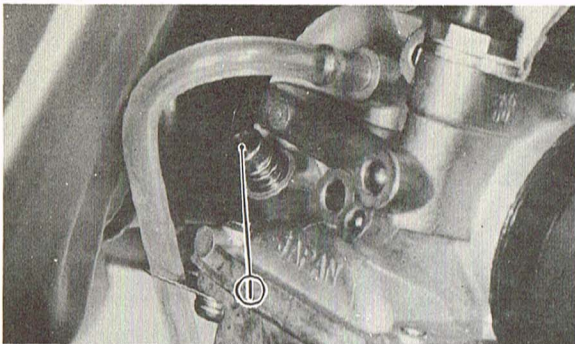

1. Pilot air screw

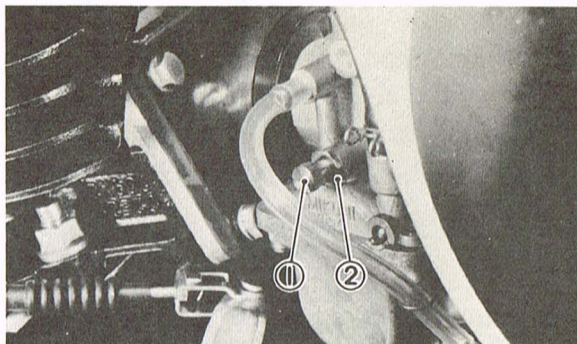

1. Throttle stop screw 2. Lock nut

3. Turn the throttle stop screw until idle is at desired r/min.

NOTE: _____
A lock nut is incorporated for positive retention of throttle stop screw.

4. Turn the pilot air screw in or out until idle speed is at highest r/min.
5. Turn the throttle stop screw in or out until idle speed is at desired r/min.

NOTE: _____
Pilot air and throttle stop screws should be so adjusted that engine response from idle position is rapid and without hesitation.

Pilot air screw: Back out 1-3/4 turns.

Idle speed: As desired

If the engine, when warm, hesitates after adjusting as described, turn the idle air mixture screw in or out in 1/4 turn increments until the problem is eliminated.

Replacement of main jet:

NOTE: _____
Generally, in a race held in the rain or at altitudes, the main jet should be replaced by a one-step smaller type.

1. Turn fuel petcock lever to the "OFF" position.
2. Remove the gasoline tank fuel line into from the fitting at the carburetor.
3. Loosen the manifold and inlet joint bands (hose clamps).
4. Rotate carburetor, exposing main jet cover bolt.
5. Remove bolt. Main jet is located directly behind bolt.

WARNING: _____
Removing the main jet cover bolt will allow the fuel in the float bowl to

drain. Do not remove if engine is hot. Place a rag under carburetor to catch overflow. Remove bolt in well-ventilated area. Do not remove near open flame. Always clean and dry machine after reassembly.

6. Remove the main jet. Change as required. Reinstall cover bolt and reassemble, reversing steps 2 through 5.

Main jet: #280

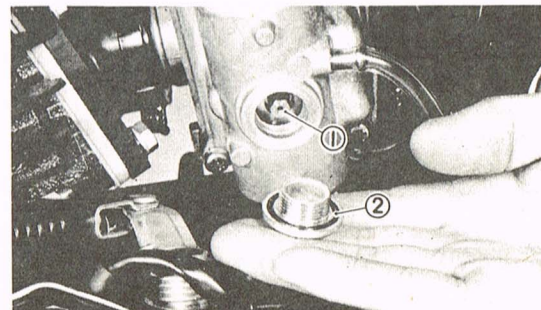

1. Main jet 2. Cover bolt

Ignition timing

Ignition timing must be set with a dial gauge (to determine piston position).

Proceed as follows:

1. Remove spark plug, muffler and screw Dial Gauge Stand into spark plug hole.
2. Insert Dial Gauge Assembly with a 56 mm (2.2 in) extension (needle) into stand.
3. Remove left engine crankcase cover.

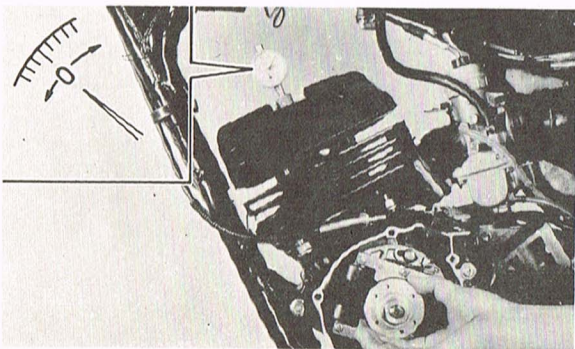

4. Rotate rotor until piston is at top-dead center (T.D.C.). Tighten set screw on

spark plug stand to secure dial gauge assembly. Set the zero on dial gauge face to line up exactly with dial gauge needle. Rotate rotor back and forth to be sure that gauge needle does not go past zero.

5. Starting at T.D.C., rotate rotor clockwise until dial indicator reads 1.2 mm (0.047 in) before top-dead-center (B.T.D.C.)

Ignition timing: 1.2 mm \pm 0.15 mm
(0.047 in \pm 0.006 in) B.T.D.C.

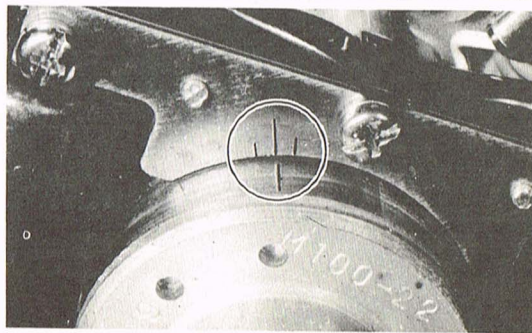

6. Check to see that the rotor timing mark aligns with the stator timing mark. To adjust, loosen the two stator retaining screws and rotate the stator. Tighten screws and recheck the ignition timing.

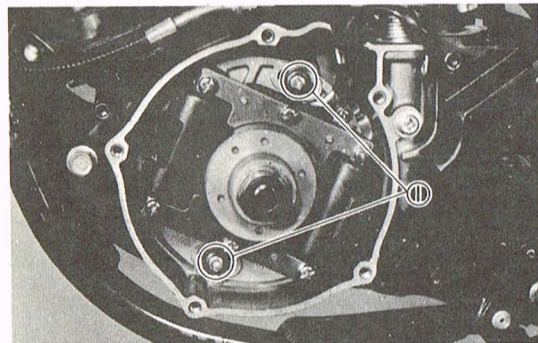

1. Retaining screw

7. Remove dial gauge assembly and stand. Replace spark plug.

Spark plug torque:
2.5 m-kg (18 ft-lb)

8. Replace engine crankcase cover.

Air filter cleaning

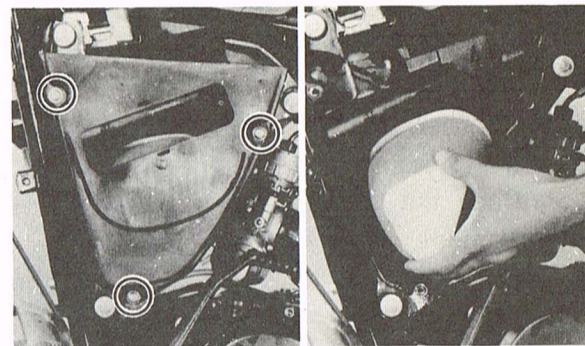

1. Wash the element gently, but thoroughly, in solvent.
2. Squeeze the excess solvent out of the element and let dry.
3. Pour a small quantity of air cooled 2-stroke engine oil onto the filter element and work thoroughly into the porous foam material.

NOTE: _____

In order to function properly, the element must be damp with oil at all times, but not dripping with oil.

4. Re-insert the filter element guide into the element.
5. Coat the sealing edges of the filter element with light grease. This will provide an air-tight seal between the filter case cover and filter seat.

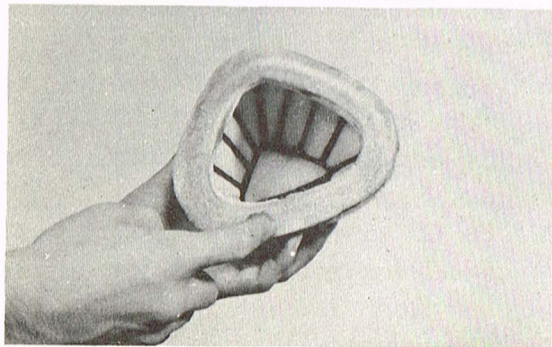

6. Reinstall the element assembly and parts removed for access.

NOTE: _____

Each time filter element maintenance is performed, check the air inlet to the filter case for obstructions. Check the air cleaner joint rubber to the carburetor and manifold fittings for an air-tight seal. Tighten all fittings thoroughly to avoid the possibility of unfiltered air entering the engine.

CAUTION: _____

Never operate the engine with the air filter element removed. This will allow unfiltered air to enter, causing rapid wear and possible engine damage. Additionally, operation without the filter element will affect carburetor jetting with subsequent poor performance and possible engine overheating.

CLUTCH

Mechanism adjustment:

1. Fully loosen the cable in-line length adjuster lock nut and screw in the adjuster until tight.
2. Turn the handle lever adjuster in.
3. Remove the rear brake adjuster, foot rest (R) and kick crank.
4. Drain the transmission oil and remove the crankcase cover (R).
5. Loosen the adjuster lock nut.

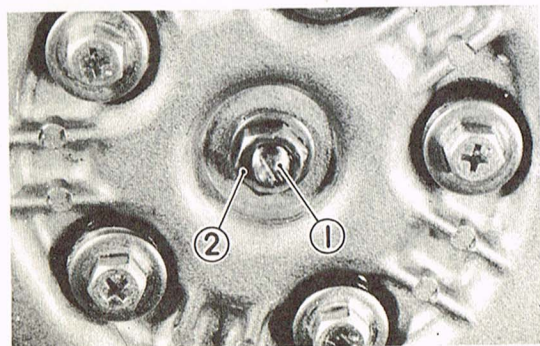

1. Adjuster 2. Lock nut

6. Push the push lever forward with your finger until it stops. With the push lever in this position, turn the adjuster in until the push lever mark and crankcase match mark are aligned. Tighten lock nut.

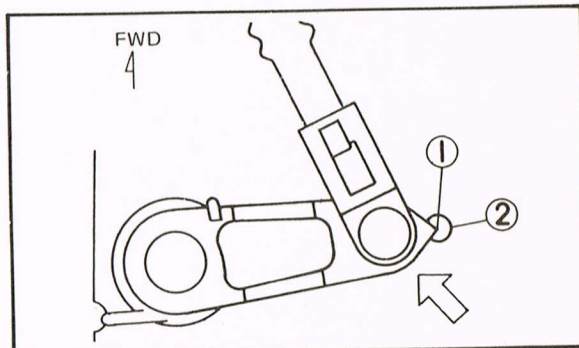

1. Push lever mark 2. Case match mark

7. Install the crankcase cover, kick crank, foot rest (R) and rear brake adjuster. Re-adjust brake pedal and clutch lever freeplays as required.

Freeplay adjustment:

Loosen either the handle lever adjuster lock nut or the cable length adjuster lock nut. Next, fully turn the lever adjuster in and adjust the lever freeplay by turning the cable length adjuster in or out.

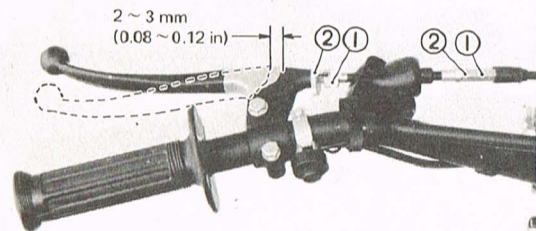

1. Adjuster 2. Lock nut

Front brake

Front brake should be adjusted to suit rider preference with a minimum cable slack of 5 — 8 mm (0.2 — 0.32 in) play at the brake lever pivot point.

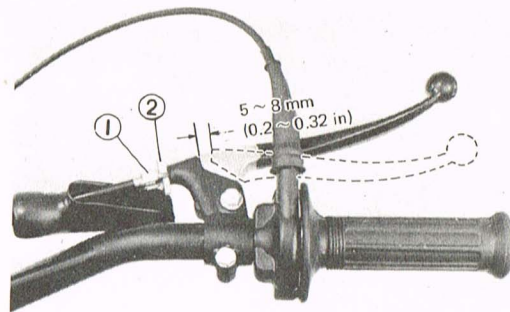

1. Adjuster 2. Lock nut

Adjustment is accomplished at one of two places; either the handle lever holder or the front brake shoe plate.

1. Loosen the lock nut and fully turn the lever holder adjuster in.
2. Loosen the adjuster lock nut.
3. Turn the cable length adjuster in or out until adjustment is suitable.
4. Tighten the lock nut.

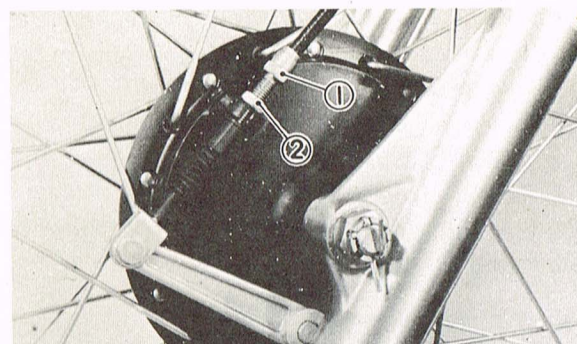

1. Adjuster 2. Lock nut

REAR BRAKE

Brake pedal position adjustment:

The position of the rear brake pedal should be adjusted so as to suit the rider. Loosen the lock nut and adjust the pedal height by turning the adjusting bolt. After adjusting, check for correct rear brake play. Do not forget to tighten the lock nut.

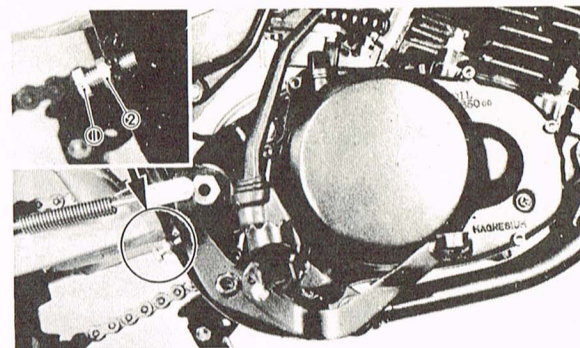

1. Adjusting bolt 2. Lock nut

Brake pedal freeplay adjustment:

Adjust rear brake pedal play to suit, providing a minimum of 20 — 30 mm (0.80 — 1.20 in) freeplay. Turn the adjusting nut on the rear brake ferrule in or out until brake pedal freeplay is suitable.

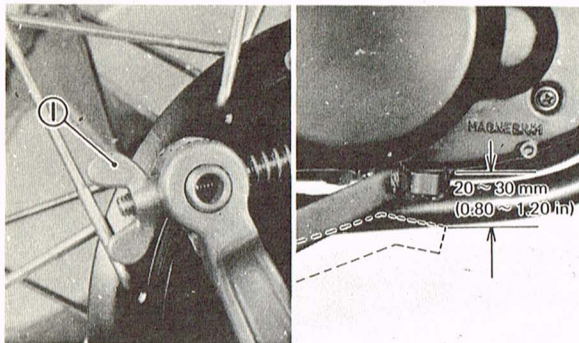

1. Adjusting nut

NOTE:

Rear brake pedal adjustment must be checked anytime chain is adjusted or rear wheel is removed and then reinstalled.

Drive chain

Place a proper-size wooden box or a stand under the engine to keep the rear wheel raised off the floor.

Push down the chain tensioner to let the chain free from it.

In this state, measure the chain play in the

middle of the upper portion of the chain as follows.

Chain free play:
55 ~ 60 mm (2.17 ~ 2.36 in)

Adjust the chain if the play exceeds the specified value.

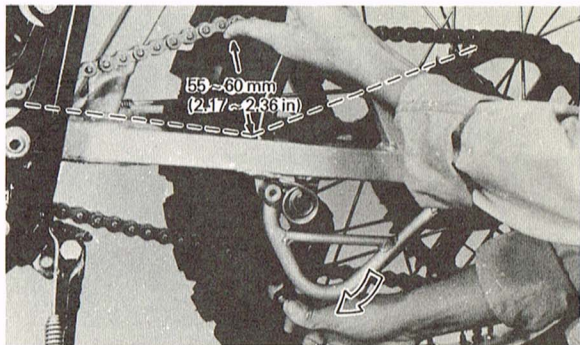

To adjust drive chain, proceed as follows:

1. Remove rear axle cotter pin.
2. Loosen axle nut.

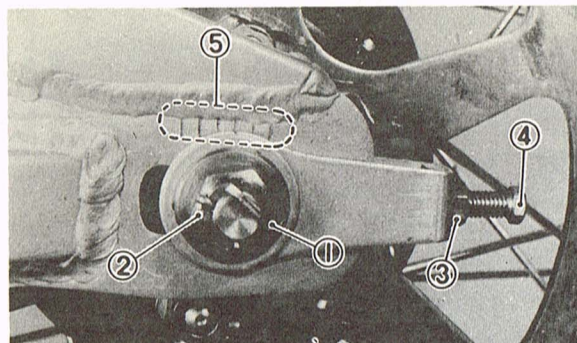

1. Cotter pin 3. Lock nut 5. Adjusting mark
2. Axle nut 4. Adjuster

3. Turn adjuster (left and right) until the adjusting marks on chain pullers are aligned with the adjusting marks on each side of the swing arm. In this step, make sure that the adjusting marks are in the same position on both side. Tighten lock nuts.

4. Tighten the rear axle nut.

Torque: 8.5 m-kg (61 ft-lb)

5. Install a new cotter pin.
6. Check brake pedal freeplay.

CAUTION:

Whenever the chain is adjusted and/or the rear wheel is removed, always check the rear axle alignment and brake pedal freeplay.

Lee Waldie Craig Scott Chris Koira

FRONT FORKS

CAUTION:

To prevent an accidental explosion of air, the following instructions should be observed:

1. Use only air or nitrogen for filling. Never use any other gas. An explosion may result.
2. Never subject the front forks to fire or place them in heated a place.

Fork oil replacement:

1. Raise the front wheel off the floor with a suitable stand.
2. Remove the rubber cap and valve cap.

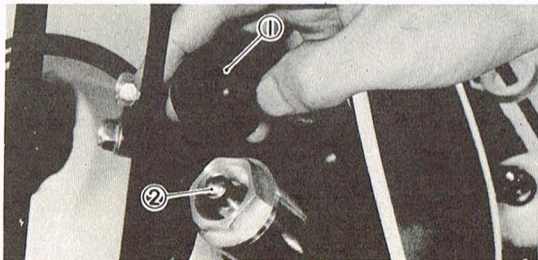

1. Rubber cap 2. Valve cap

3. Press on the valve to remove all air pressure.

CAUTION:

When the air has to extract it little by little. If not, oil will spurt out together with the air.

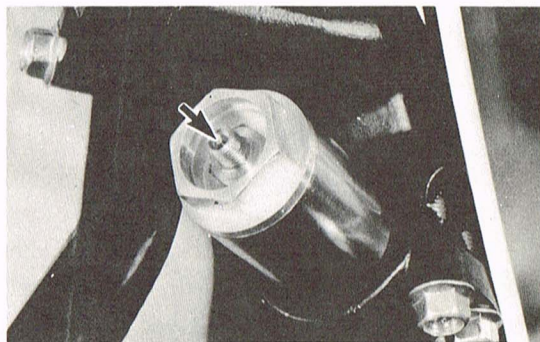

4. Remove the cap bolt assembly.
5. Remove drain screw from bottom of fork leg and drain oil.

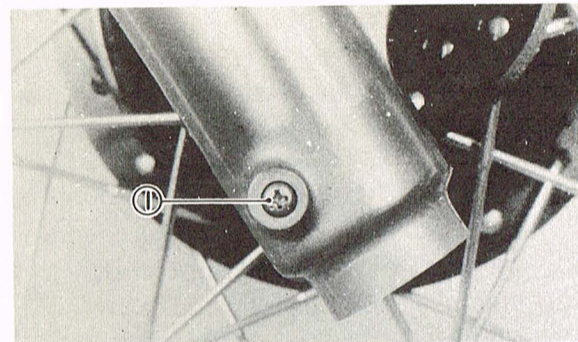

1. Drain screw

6. When most of oil has drained, slowly raise and lower outer tubes to pump out the remaining oil.
7. Replace drain screws.

NOTE:

Check gasket, replace if damaged.

8. Remove the spacer and main spring. And measure correct amount of oil and pour into each leg.

Recommended oil: SAE #15
Oil quantity: 283 cc (9.65 oz)

9. After filling with oil, measure the oil level from the inner tube top end with the forks bottomed. The oil levels must be the same.

Oil level: 181 mm (7.1 in)

Replace main spring and spacer.

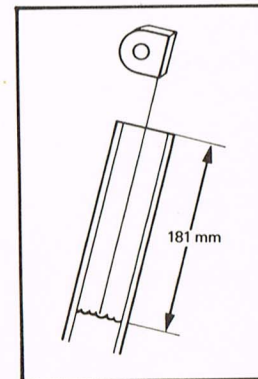

10. Inspect the O-ring on cap bolt and replace if damaged.

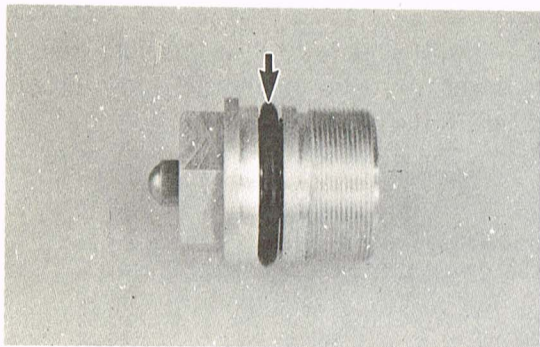

11. Install cap bolt and torque to specification.

Tightening torque:
2.0 m-kg (14 ft-lb)

12. Install valve cap and rubber cap.

Air pressure adjustment:

IMPORTANT:

Correct, exact air pressure charging is **CRITICAL** for proper fork operation.

1. Raise the front forks off the ground by placing a wooden block under the engine. (No weight on front wheel)
2. Remove the rubber cap and valve cap.
3. Fill fork with air or nitrogen gas.

CAUTION:

Never exceed 2.5 kg/cm² (35 psi).
Damage to the fork seals will result.

4. Using the air check gauge, adjust the air pressure to specification.

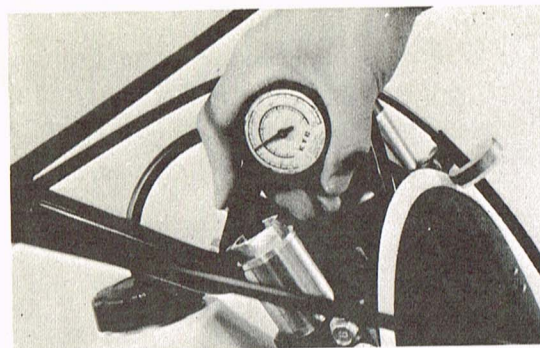

STANDARD AIR PRESSURE:
0.98 kg/cm² (13.9 psi)

ADJUSTABLE EXTENT:
0.88 ~ 1.08 kg/cm² (12.5 ~ 15.3 psi)

NOTE:

Increasing air pressure:

Initial load to increase and cushion becomes hard.

Decreasing air pressure:

Initial load to decrease and cushion becomes soft.



5. The difference between both right and left tubes should be 0.1 kg/cm² or less.

NOTE:

The needle indicating 0 on the air gauge may sometimes deflect when the gauge is inserted into oil. In this cause, loosen the screw and shake the gauge several times. Wait until the needle returns to 0 and tighten the screw.

Fork spring replacement:

In addition to the standard type, two different type fork spring are sold. A proper spring should be selected according to the conditions of a racing course or the weight of the rider.

Type		Part No.	Spring rate (kg/mm)	I.D. mark
SOFT	Spring	1W1-23141-10	K = 0.223	
	Spacer	1W1-23118-10	—	L = 80 mm
STD	Spring	1W1-23141-LO	K = 0.255	
	Spacer	1W1-23118-LO	—	L = 30 mm
HARD	Spring	1W1-23141-20	K = 0.279	
	Spacer	1W1-23118-LO	—	L = 30 mm

NOTE: _____

1. Replace the spring and spacer in a set.
2. I.D. marking can be found scored on the top of the spring end.

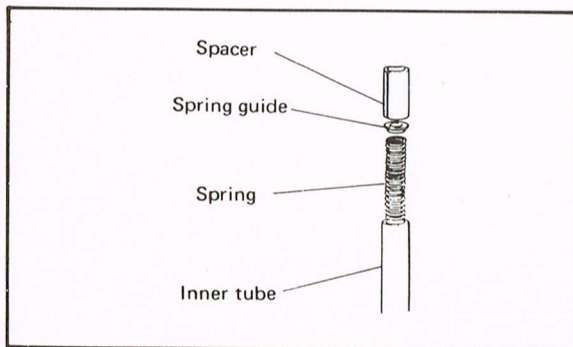

Steering head adjustment

1. With front wheel elevated, grab bottoms of fork legs and gently push and pull to check steering head free play. There should be no noticeable free play.

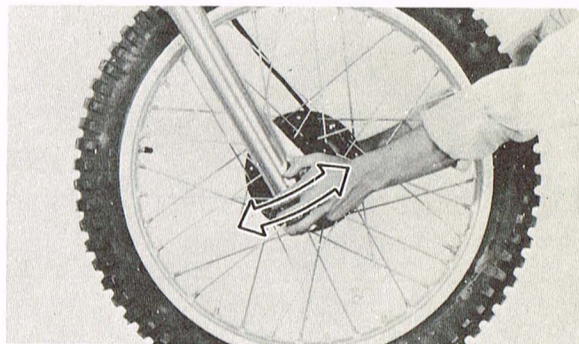

2. To adjust, first loosen upper stem pinch bolt.
3. Loosen steering fitting bolt.

4. Use steering nut wrench to tighten ring nut. Tighten until free play is eliminated.

NOTE: _____
Forks must swing from lock to lock without binding or catching.

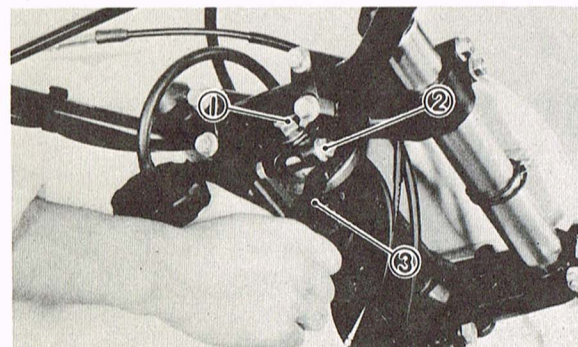

1. Steering fitting bolt
2. Stem pinch bolt
3. Steering nut wrench

5. Tighten fitting bolt and torque to specification.

Fitting bolt torque:
5.5 m-k (40 ft-lb)

6. Tighten pinch bolt at fork crown and torque to specification.

Stem pinch bolt torque:
1.5 m-k (11ft-lb)

REAR SHOCK (MONOCROSS SUSPENSION" DE CARBON" SYSTEM)

—WARNING:—READ CAREFULLY—

This shock absorber contains highly compressed nitrogen gas.

Read and understand the following information before handling the shock absorber. The manufacturer cannot be held responsible for property damage or personal injury that may result from improper handling.

1. Do not tamper with or attempt to open the cylinder assembly. Injury may result.
2. Do not subject shock absorber to an open flame or other high heat. This may cause the unit to explode due to excessive gas pressure.
3. Do not deform or damage the cylinder in any way. Cylinder damage will result in poor damping performance.

4. Handle it with great care, for a score or scratch in the piston rod sliding portion will cause oil leakage.
5. Never remove the plug on the cylinder bottom. Injury may result.

Notes on disposal (Yamaha dealers only):

Gas pressure must be released before disposal of shock absorber. To do so, drill a 2 ~ 3 mm (0.08 ~ 0.12 in) hole through the cylinder wall at a point 10 ~ 15 mm (0.4 ~ 0.6 in) above the bottom of the cylinder.

—CAUTION:—

Wear eye protection to prevent eye damage from escaping gas and/or metal chips.

—WARNING:—

To dispose of a damaged or worn out shock absorber, take the unit to your Yamaha dealer for this disposal procedure.

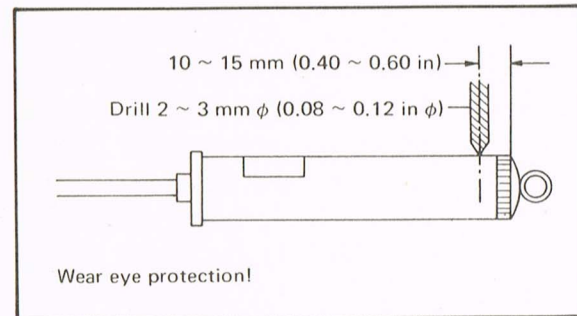

Adjustment:

- When bottoming feels excessive and too soft:
 1. Increase the spring pre-load
 2. Make damping performance stiffer
- When springing feels excessive and too hard:

1. Decrease the spring pre-load
2. Make damping performance softer

Changing damping performance:

Adjustment can be made without removing the shock absorber. Turn the adjusting nut with a slottedhead screw driver through the hole provided one each on either side of the frame.

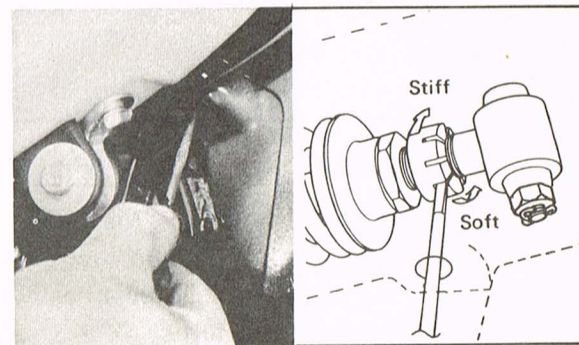

- * To make it stiffer, screw IN the adjuster.
- * To make it softer, screw OUT the adjuster.

Make notch by notch adjustment and test it by riding after each adjustment.

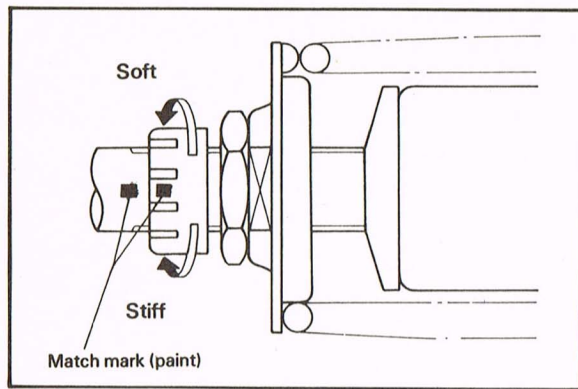

NOTE: Turn the adjuster until it clicks. Maximum (Minimum) extent can be known by the position where turning suddenly feels heavy (light). Do not give any more turns.

WARNING:
Do not increase damping beyond 5 notches from the standard setting.
Do not decrease damping beyond 11 notches from the standard setting.

Changing suspension spring preload:
Perform this adjustment with a special wrench (in the owner's tool).

1. Remove the shock absorber.
2. Loosen the adjuster lock nut.
3. To increase fitting load, screw IN the adjuster.
To decrease fitting load, screw OUT the adjuster.

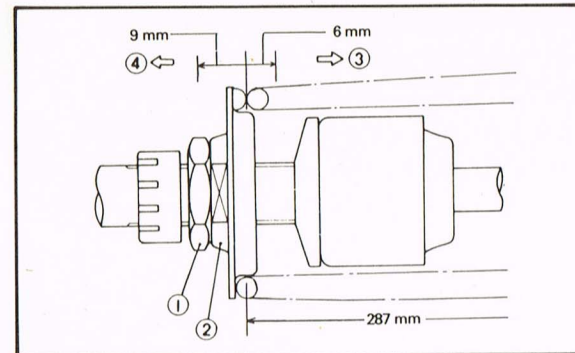

1. Lock nut
2. Adjusting nut
3. Increase
4. Decrease

NOTE: Initial fitting length is set for 287 mm (11.30 in). Adjustable extent is maximum 296 mm (11.65 in) and minimum 281 mm (11.06 in). Be sure to adjust within the above limits.

4. Tighten the lock nut by retaining the adjuster at turning position.

Tightening torque:
6.0 m·kg (43 ft·lb)

Gas pressure:

The gas pressure can be adjusted. For this adjustment, take the unit to your Authorized Yamaha dealer.

Rear shock spring replacement:

In addition to the standard type, two different type rear shock springs are sold. A proper type should be selected according to the conditions of a racing course or the weight of the rider.

Type	Part No.	Spring rate (kg/mm)	Color code
SOFT	90501-98478	K1 = 1.9 K2 = 4.0	White/ Red
STD	90501-98466	K1 = 2.31 K2 = 4.01	White/ Blue
HARD	90501-98477	K1 = 2.7 K2 = 4.0	White/ Yellow

NOTE: _____
Code color is shown on the end of the spring.

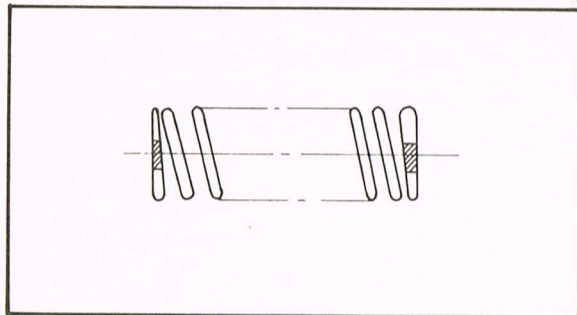

MINOR REPAIR CARBURETOR

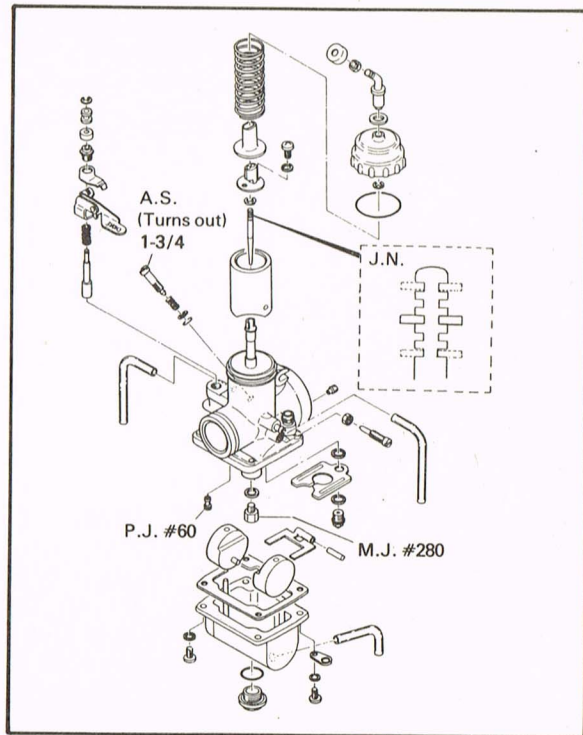

Inspection

1. Examine carburetor body and fuel passages. If contaminated, wash carburetor in petroleum based solvent. Do not use caustic carburetor cleaning solutions. Blow out all passages and jets with compressed air.
2. Examine condition of floats. If floats are leaking or damaged, they should be replaced.
3. Inspect inlet needle valve and seat for wear or contamination. Replace these components as a set.

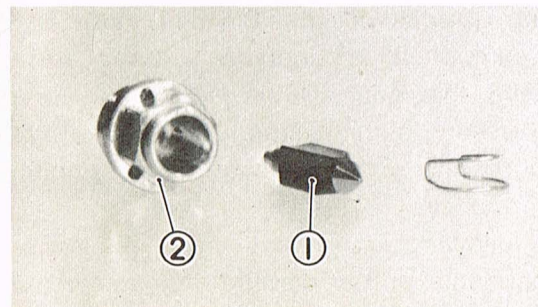

1. Needle valve 2. Valve seat

Adjustments

1. Float arm height
 - a. Checking

Hold the carburetor in an upside down position. While holding the float arm so the tang is just touching the float needle, measure the distance from the top of the float arm to the float bowl gasket surface. Both arms must be the same height.

Float arm height:
23.5 mm (0.925 in)
Level with carburetor base

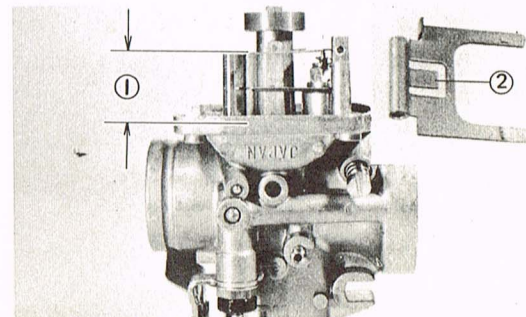

1. Float arm height 2. Tang

b. Adjustment

CAUTION:

Check the needle valve and valve seat for wear before adjustment.

Make the adjustment by bending the tang on the float arm.

2. Jet needle

The mid-range air/fuel supply is affected by the position of the needle in the needle jet. If it is necessary to alter the mid-range air/fuel mixture characteristics of the machine, the jet needle position may be changed. Move the jet needle up for a leaner condition or toward the bottom position for a richer condition.

Jet needle type: 6F22-3
Clip position: No. 3 Groove

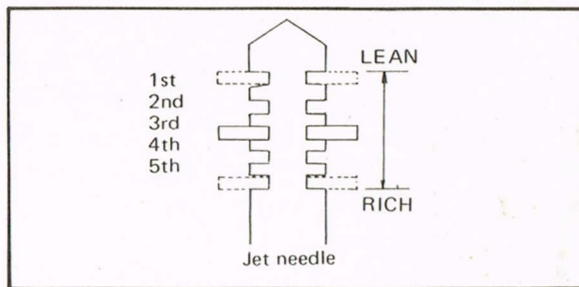

Troubleshooting

A motorcross machine requires immediate, predictable throttle response over a wide operating range. Cylinder porting, combustion chamber compression, ignition timing, muffler design, and carburetor size and component selection are all balanced to achieve this goal. However, variations in temperature, humidity and altitude will affect carburetion and consequently, engine performance.

The following list gives each of the major components of the carburetor that can be

readily changed in order to modify performance if required. If you are unfamiliar with carburetor theory, we suggest you refrain from making changes. Quite often, a performance problem is caused by another related component, such as the exhaust system, ignition timing or combustion chamber compression.

NOTE:

See **MECHANICAL ADJUSTMENTS** for additional carburetor adjustments.

Lee Waldie Craig Scott Chris Koira

Pilot air screw

Controls the ratio of air-to-fuel in the idle circuit. Turning the screw in decreases the air supply, giving a richer mixture.
OPERATING RANGE MOST AFFECTED BY THIS ADJUSTMENT: ZERO TO 1/8 THROTTLE.

Pilot jet:

Controls the ratio of fuel-to-air in the idle circuit. Changing the jet to one with a higher number supplies more fuel to the circuit giving a richer mixture.

OPERATING RANGE MOST AFFECTED BY THIS JET: ZERO TO 1/8 THROTTLE.

Throttle valve (slide):

The throttle valve (slide) has a portion of the base cut away to control air flowing over the main nozzle. A wider angle (more "cutaway") will create a leaner mixture. Throttle valves are numbered according to the angle of the cutaway. The higher the number, the more cutaway, the leaner the mixture.

OPERATING RANGE MOST AFFECTED BY THE THROTTLE VALVE: 1/8 to 1/4 (+) THROTTLE.

Jet Needle:

The jet needle is fitted within the throttle valve. The tapered end of the needle fits into the main nozzle outlet. Raising the needle allows more fuel to flow out of the needle. Moving the needle clip from the first, or top groove, through the fifth, or bottom groove, will give a correspondingly richer mixture. OPERATING RANGE MOST AFFECTED BY THE JET NEEDLE: 1/4 to 3/4 (+) THROTTLE.

Main jet:

The Main jet controls overall fuel flow through the main nozzle. Changing the jet to one with a higher number supplies more fuel to the main nozzle giving a richer mixture. OPERATING RANGE MOST AFFECTED BY THE MAIN JET: 3/4 TO FULL THROTTLE:

NOTE:

Excessive changes in main jet size can affect performance at all throttle positions.

CAUTION:

The fuel/air mixture ratio is a governing factor upon engine operating temperature. Any carburetor changes, whatsoever, must be followed by a thorough spark plug test.

REED VALVE

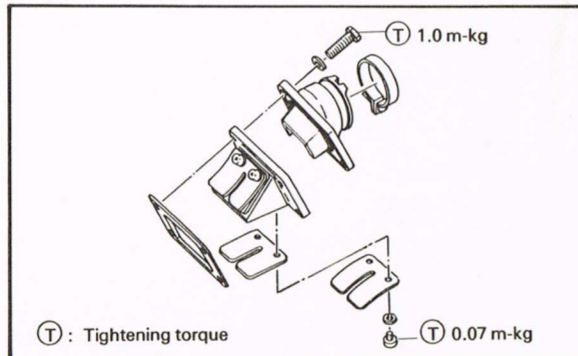

Inspection

1. Inspect rubber intake manifold for signs of weathering, checking or other deterioration.

2. Inspect reed petals for signs of fatigue and cracks. Reed petals should fit flush or nearly flush against neoprene seats. If in doubt as to sealing ability, apply suction to carburetor side of assembly. Leakage should be slight to moderate.
3. The valve stopper controls the movement of the valve. Check clearance "a".

Standard value "a":

8.1 ~ 8.5 mm (0.32 ~ 0.33 in)

If it is 0.5 mm more or less than specified, replace the valve stopper.

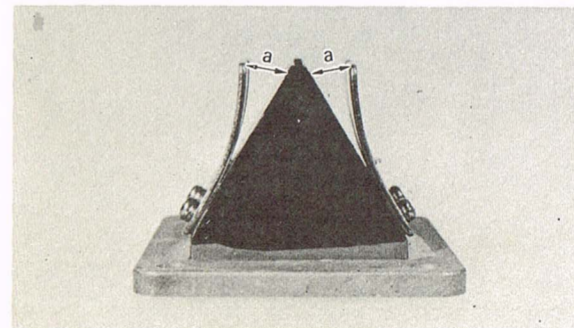

4. Check reed valve for bending. If beyond tolerance, replace reed valve.

Reed valve bending limit:
0.3 mm (0.012 in)

5. During reassembly, note the cut in the lower corner of the reed and stopper plate. Use as aid to direction of reed installation.

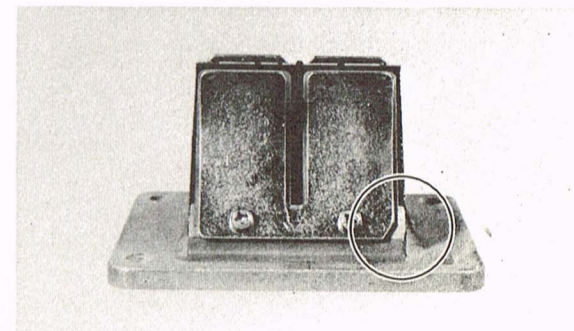

TOP END AND MUFFLER

1. Remove the two bolts and remove seat.
2. Remove the tank fitting band and securing bolt from fuel tank.
3. Turn the fuel petcock to "OFF" position and disconnect the fuel pipe. Remove tank.
4. Remove coil spring at muffler to cylinder joint and remove muffler, and silencer.
5. Remove the clutch wire at handle lever first and then at clutch push lever.
6. Remove spark plug lead wire.

CYLINDER HEAD AND CYLINDER

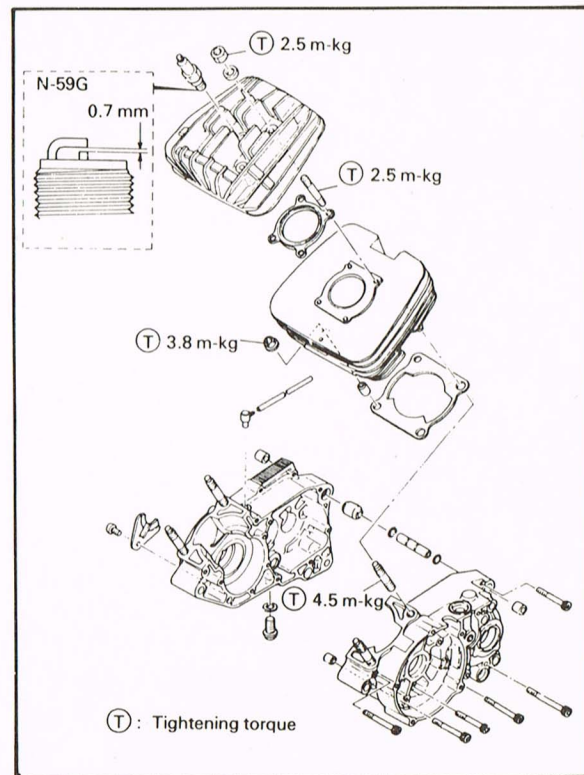

PISTON

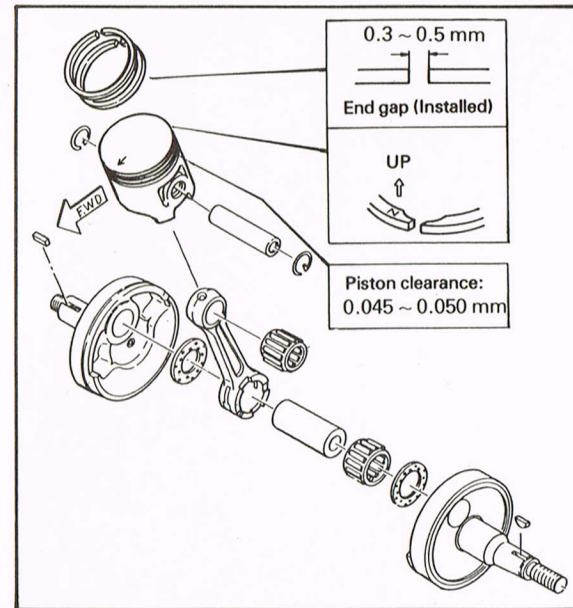

NOTE:

Stuff a clean shop rag into crankcase cavity, around rod, to prevent dirt and other foreign particles from entering.

MAINTENANCE

Decarbonizing

Using a rounded scraper, remove carbon deposits from the combustion chamber, piston crown, exhaust port and silencer.

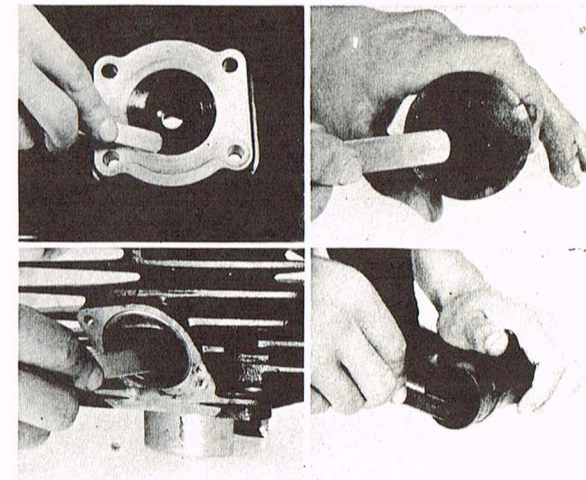

Inspection

1. Ring end gap
Insert ring into cylinder. Push down

approximately 20 mm (0.79 in) using piston crown to maintain right angle to bore. Measure installed end gap. If beyond tolerance, replace ring.

Ring end gap, installed:
0.3 ~ 0.5 mm (0.012 ~ 0.020 in)

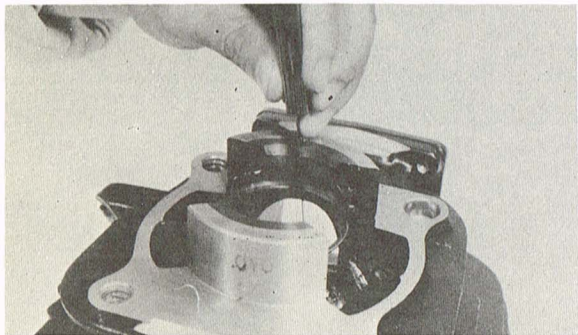

2. Piston clearance

Cylinder bore measurement:

Measure front-to-rear, side-to-side at top,

center and bottom just above exhaust port. If over tolerance and not correctable by honing rebore to next over-size.

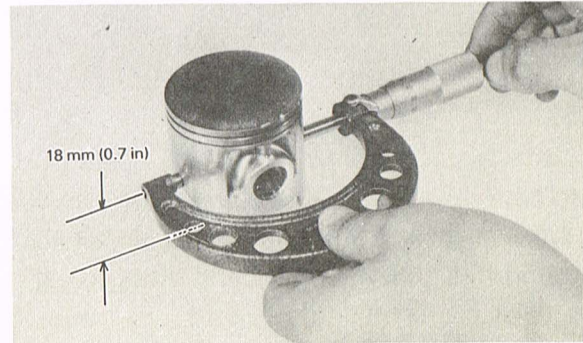
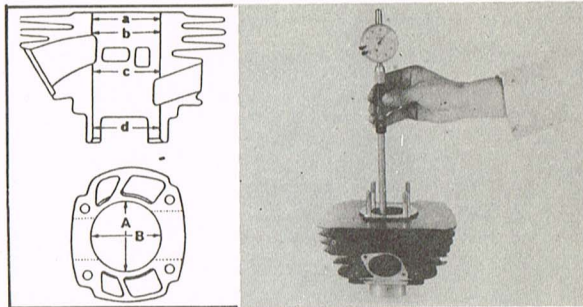

Piston O.D. measurement:

To measure a piston, measure across the skirts at a height of 18 mm (0.7 in) from bottom of piston skirts.

Piston clearance =

Minimum cylinder dia. — Maximum piston dia.

Nominal piston clearance:

0.045 ~ 0.050 mm (0.0018 ~ 0.0020 in)

Maximum wear limit:

0.1 mm (0.0039 in)

Piston pin, bearing

1. Check the pin for signs of wear. If any wear is evident, replace pin and bearing.
2. Check the pin and bearing for signs of heat discoloration. If excessive (heavily blued), replace both.
3. Check the bearing cage for excessive wear. Check the rollers for signs of flat spots. If found, replace pin and bearing.

Crankshaft specifications

Deflection tolerance (A)		Flywheel width (B)
0.03 mm	0.03 mm	55.90 ~ 55.95 mm (2.201 ~ 2.203 in)

Rod clearance			
Axial (C)		Side (D)	
New	Max.	Min.	Max.
0.8 ~ 1.0 mm (0.003 ~ 0.04 in)	2.0 mm (0.079 in)	0.2 mm (0.008 in)	0.7 mm (0.028 in)

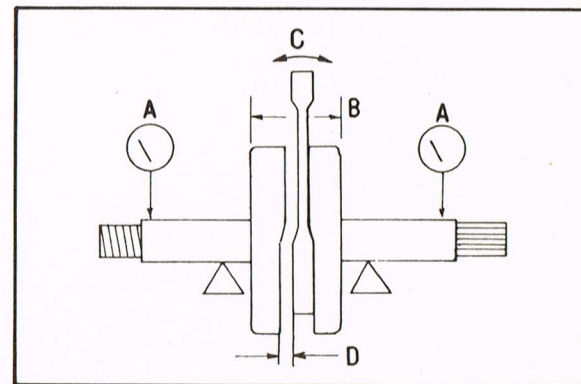

CLUTCH

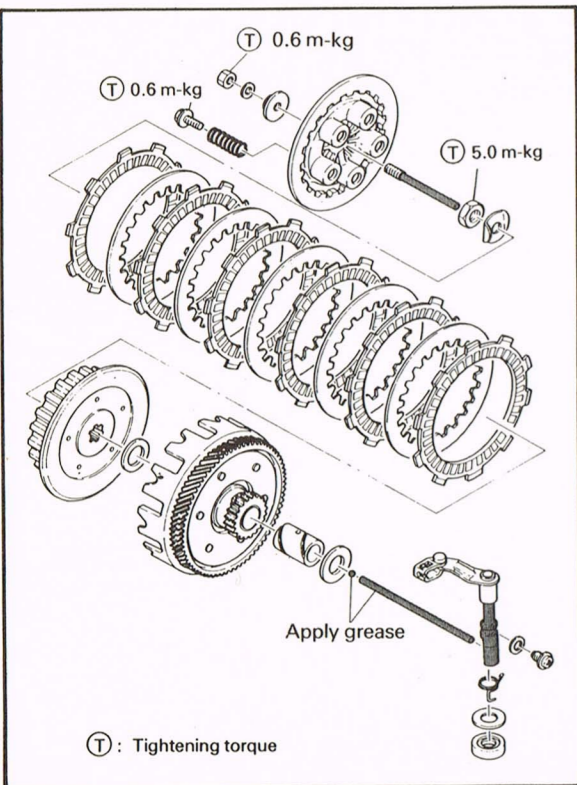

Removal:

Using the clutch holding tool, remove the clutch securing nut and lock washer.

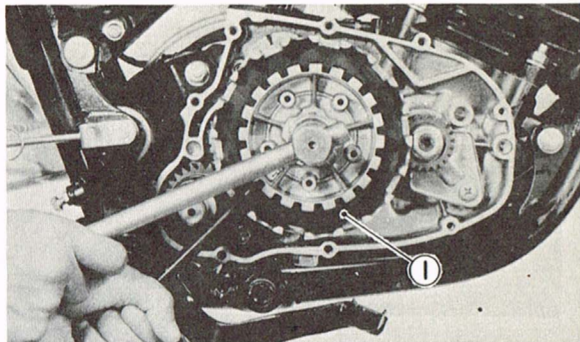

1. Clutch holding tool (90890 - 01022)

Troubleshooting:

1. Measure the friction plates at three or four points. If their minimum thickness exceeds tolerance, replace all plates.

	New	Wear limit
Friction plate thickness	3.0 mm (0.12 in)	2.7 mm (0.11 in)

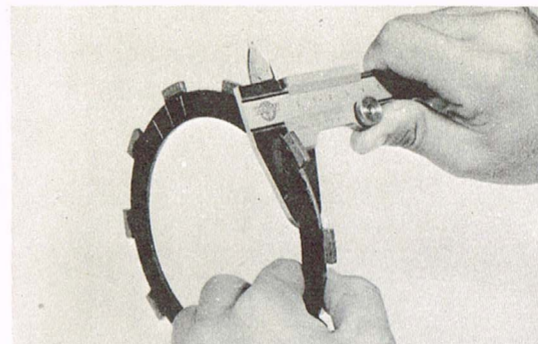

2. Check the plates for signs of warpage and heat damage, replace as required.

NOTE:

For optimum performance, if any plate requires replacement, it is advisable to replace the entire set.

3. Measure each clutch spring. If beyond tolerance replace.

	New	Minimum
Clutch spring free length	36 mm (1.42 in)	35 mm (1.38 in)

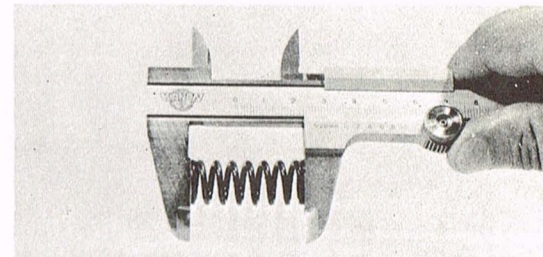

4. Roll the push rod across a surface plate. If rod is bent, replace.

Bend limit: 0.15 mm (0.006 in)

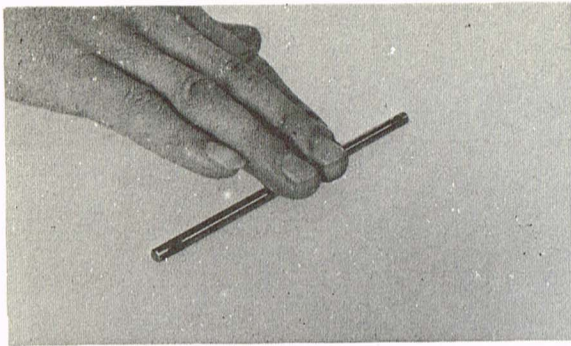

5. Check the bushing and spacer for signs of galling, heat damage, etc. If severe, replace as required.
6. Check dogs on driven gear (clutch housing). Look for cracks and signs of galling on edges. If moderate, deburr. If severe, replace.
7. Check splines on clutch boss for signs of galling. If moderate, deburr. If severe, replace.

NOTE:
Galling on either the friction plate dogs of the clutch housing or clutch plate splines of the clutch boss will cause erratic clutch operation.

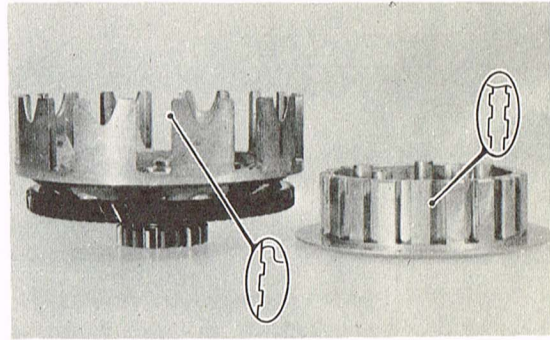

Primary reduction

If primary drive and driven gears produce excessive noise during operation, gear lash may be incorrect. Marks are scribed on the side of each gear.

And in replacement, a gear having the same mark as before must be used.

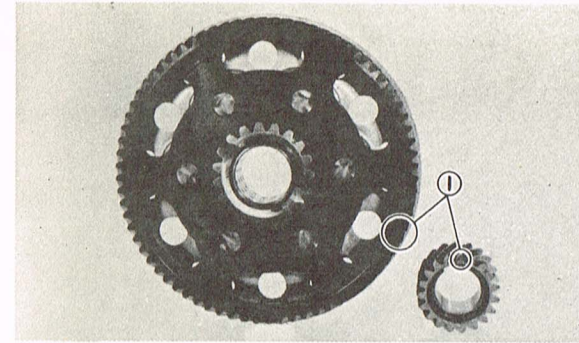

1. Mark

KICK STARTER

Inspection:

1. The pressure of the kick clip is 0.8 ~ 1.5 kg. If above pressure is too strong, spring wear and kick starter slipping will result. If it is too weak, the same slippage will occur particularly at low temperatures. Do not try to bend the clip.

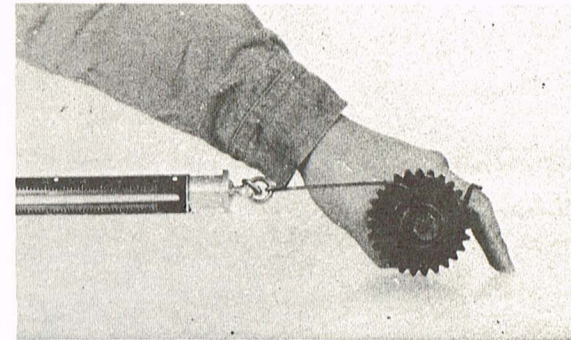

2. Check the clip for damage and wear, and determine whether or not, it should be replaced.

Installation:

1. Fit the kick gear clip in the crankcase groove, and install the kick gear assembly.

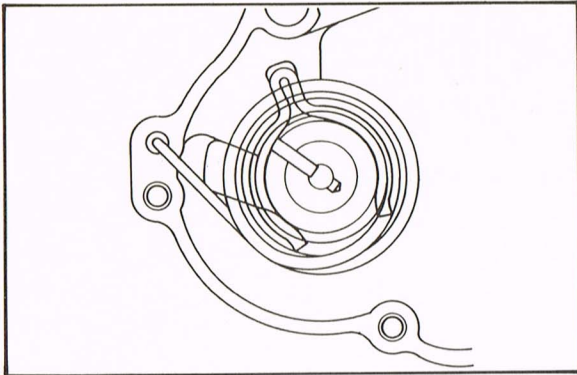

2. After installing the kick ass'y be sure to check where there it operates smoothly or not.

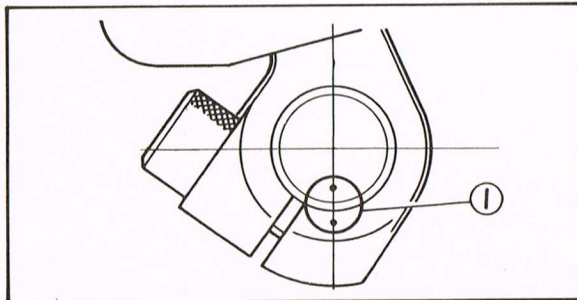

1. Matching mark

SHIFTER

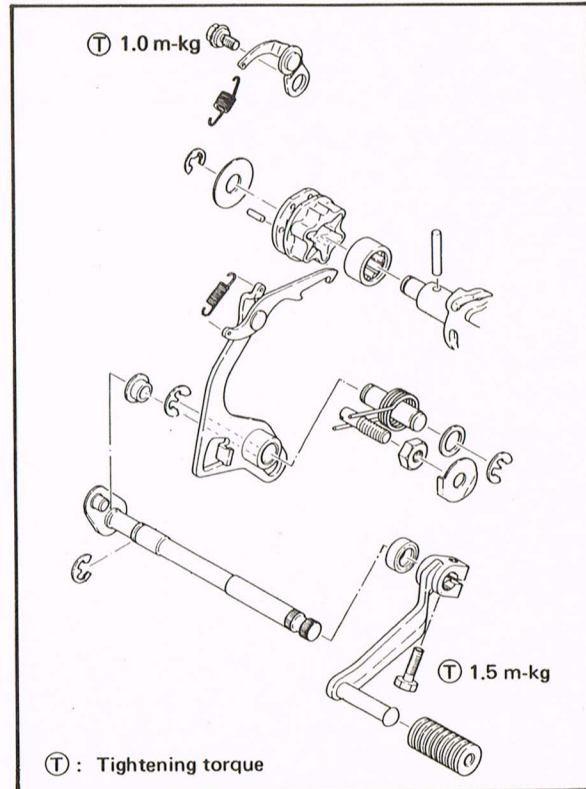

Inspection:

1. Check the segment for signs of wear or damage. Replace as required.
2. Check shift cam dowel pins and side plate for damage, or wear. Repair as required.
3. Check stopper lever roller for wear. Replace as required.

Gear shifting adjustment:

Shift into first gear. In this case, the index mark on the change lever should align perfectly with the index mark on the shift drum. If the marks are not aligned, loosen the lock nut. Turn the adjuster screw (an eccentric screw) until the marks are aligned. Tighten the lock nut.

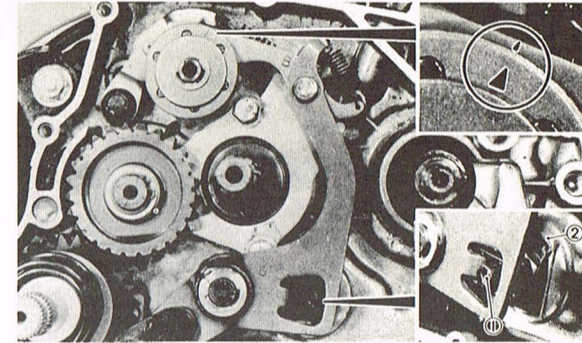

1. Adjusting screw 2. Lock nut

Drive chain

1. With the chain installed on the machine, excessive wear may be checked for by taking up chain freeplay and pulling the chain away from the rear sprocket. If the chain will lift away more than one-half the length of the sprocket teeth, remove and inspect the chain. If any portion of the chain shows signs of damage, or if either sprocket shows signs of excessive wear, remove and replace.

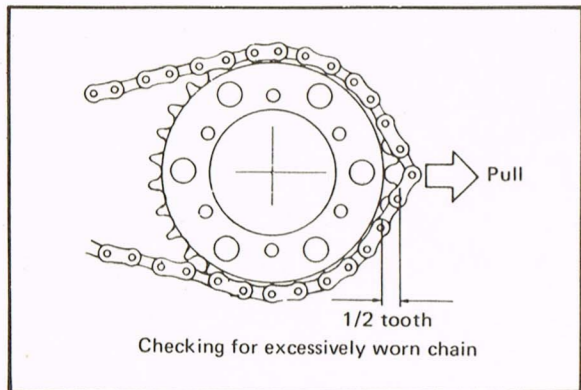

2. Check the chain for stiffness. If stiff, soak in solvent solution, clean with wire brush and dry with high pressure air. Oil chain thoroughly and attempt to work out kinks. If still stiff, replace.
3. Check the side plate for damage. Check to see if excessive play exists in pins and rollers. Check for damaged rollers. Replace as required.

NOTE:
If either chain or sprocket must be replaced due to excessive wear, be sure to replace both as a set.

Sprockets

1. Check sprocket wear. Replace if tooth width has decreased as shown.

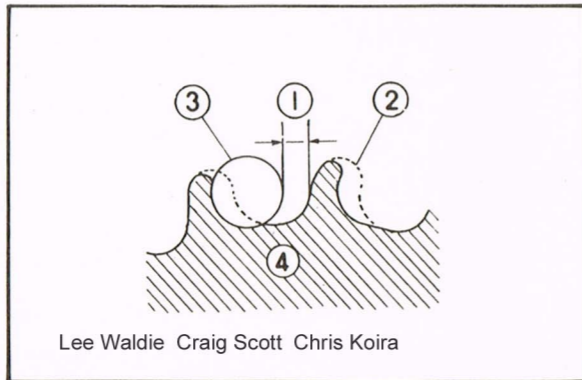

- | | |
|--------------|-------------|
| 1. 1/4 tooth | 3. Roller |
| 2. Correct | 4. Sprocket |

2. Replace if tooth wear shows a pattern resembling that in the illustration.

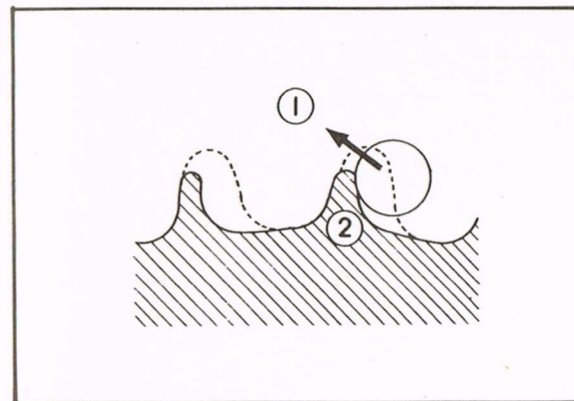

1. Slip off
2. Bend teeth

Drive sprocket securing nut torque:

5.5 m-k (40 ft-lb)

Driven sprocket securing nut torque:

4.0 m-k (29 ft-lb)

FRONT FORK

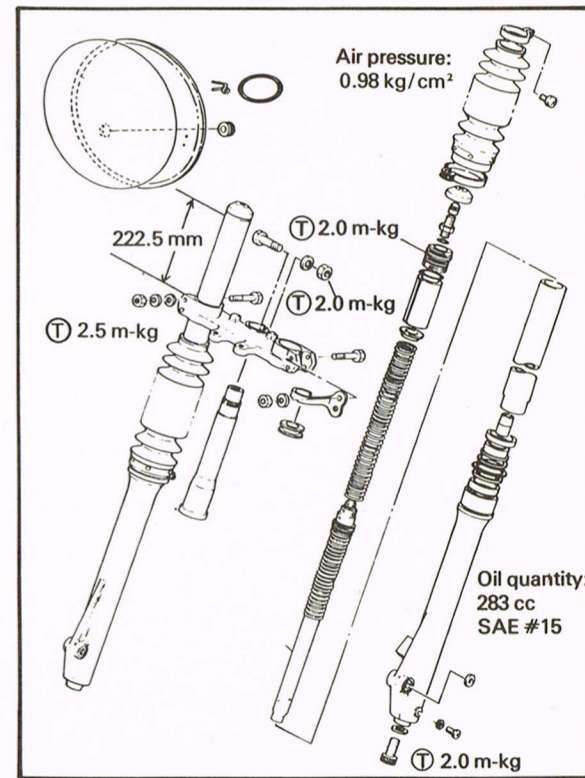

STEERING HEAD

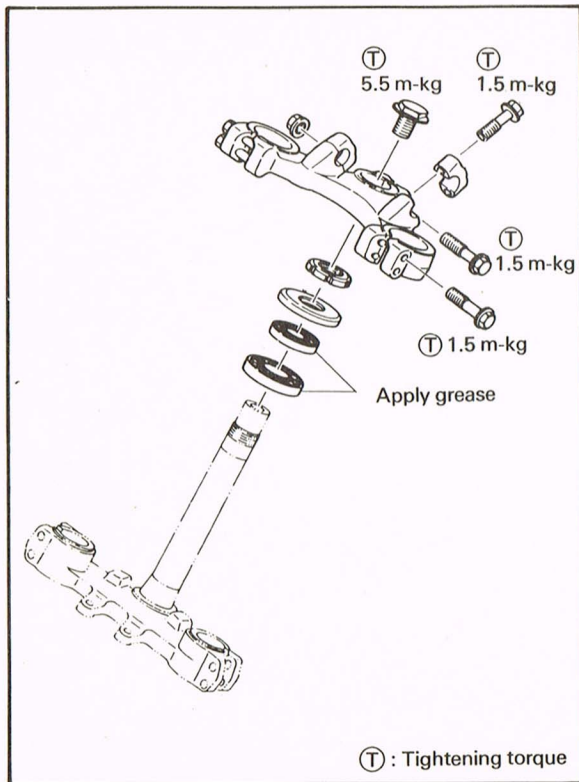

Front wheel removal

1. To remove the front wheel, disconnect the brake cable at the front brake lever.

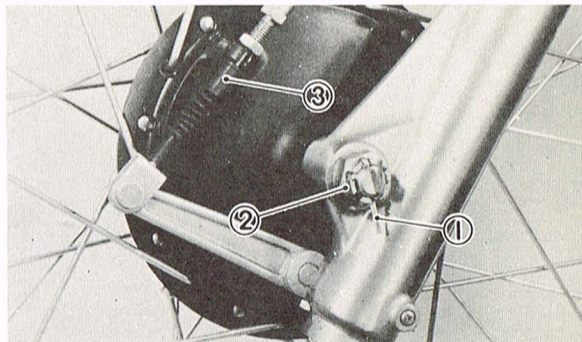

1. Cotter pin 2. Axle nut 3. Brake cable

2. Remove cotter pin from front wheel nut.
3. Remove the front wheel nut.
4. Put a box or stand under the engine.
5. Remove the front wheel axle by simultaneously twisting and pulling out on the axle. Then remove the wheel assembly.

Rear wheel removal

1. Remove the brake rod from rear shoe plate.
2. Disconnect the drive chain.
3. Remove cotter pin from rear wheel axle nut.

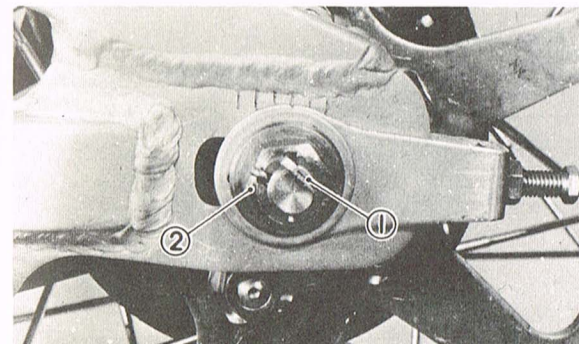

1. Cotter pin 2. Axle nut

4. Remove the rear wheel axle nut.
5. Pull out the rear wheel shaft by simultaneously twisting and pulling out.
6. Remove the rear brake shoe plate.
7. Lean the machine to the left and remove the rear wheel assembly.

Wheel installation

When installing wheels, reverse the removal procedure, taking care of the following points:

1. Check for proper engagement of the boss on the outer tube (or swing arm) with the locating slot on the brake shoe plate.

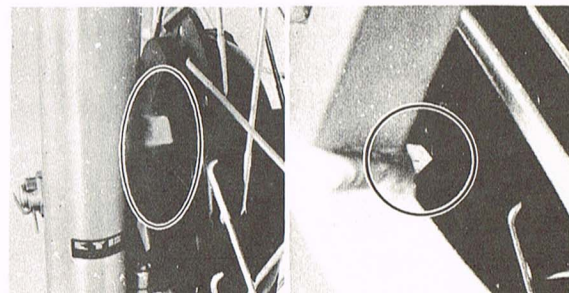

4. Make sure the axle nuts are properly tightened.

Tightening torque:

Front: 8.5 m-kg (61 ft-lb)
Rear: 8.5 m-kg (61 ft-lb)

5. Always use new cotter pins.

Checking brake shoe wear

Measure the outside diameter at the brake shoe with slide calipers. If it measures less than specified replace brake shoes.

Minimum shoe diameter:

Front: 126 mm (4.96 in)
Rear: 126 mm (4.96 in)

Minimum brake lining thickness: 2 mm

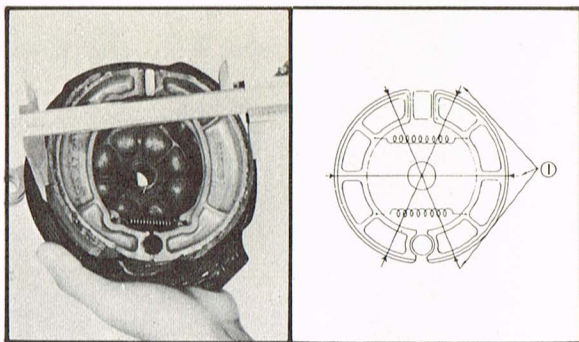

1. Measuring point

Brake drum

Oil or scratches on the inner surface of the brake drum will impair braking performance or result in abnormal noises. Remove oil by wiping with a rag soaked in lacquer thinner or solvent. Remove scratches by lightly and evenly rubbing with emery cloth.

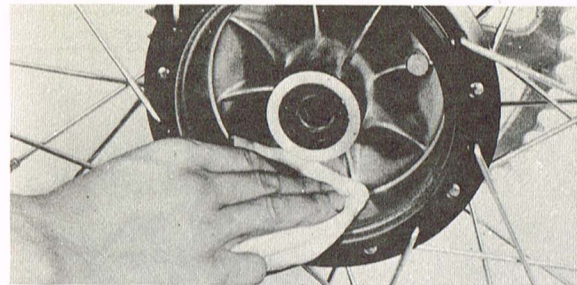

Replacing wheel bearings

If the bearings allow excessive play in the wheel or if it does not turn smoothly have your dealer replace the wheel bearings.

Spokes

Check the spokes. If they are loose or bent, tighten or replace them. The spokes should be checked before each use.

Checking rim

1. Check for cracks, bends or warpage of rim. If a rim is deformed or cracked, it must be replaced.

2. Check wheel run-out
If deflection exceeds tolerance, check wheel bearing or replace wheel as required.

Rim run-out limits:

Vertical — 2.0 mm (0.08 in)
Lateral — 2.0 mm (0.08 in)

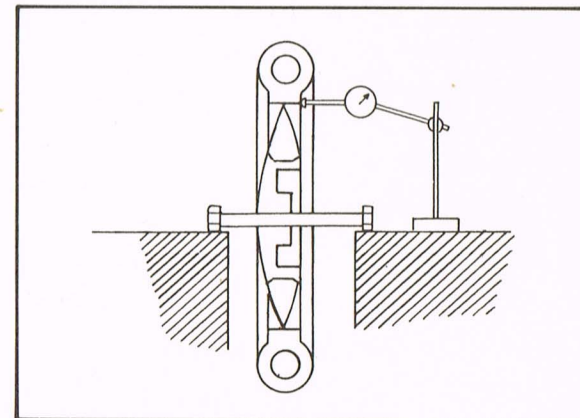

FRONT WHEEL

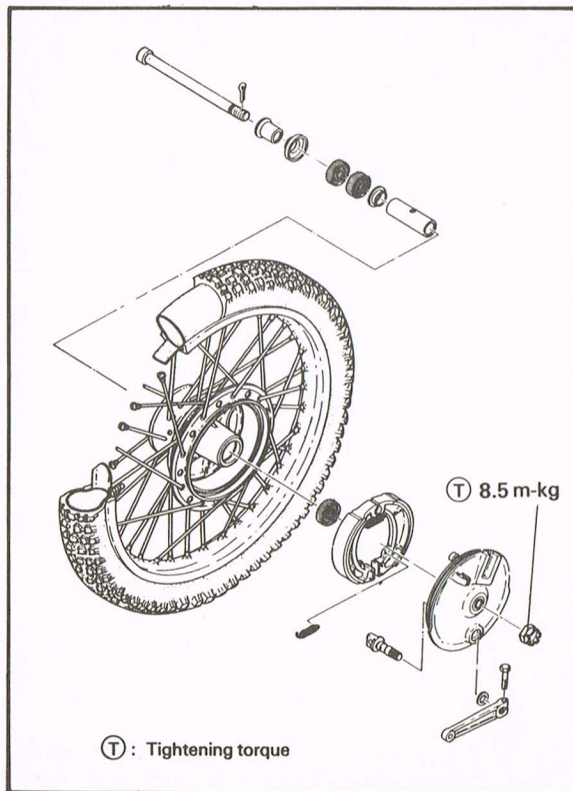

REAR WHEEL

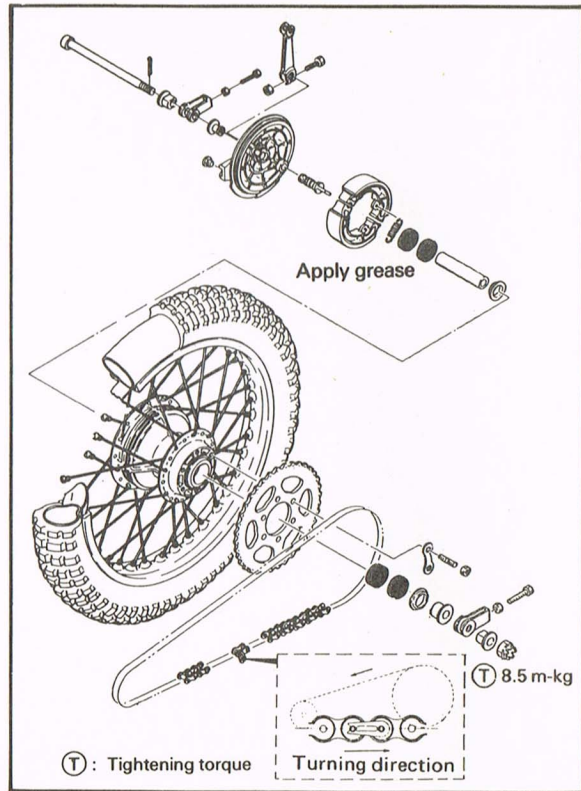

Cables

1. Remove the cable.
2. Check for free movement of the cable with its housing. If movement is obstructed, check for fraying of the cable strands. If fraying is evident, replace the cable assembly.
3. To lubricate cable, hold in vertical position. Apply lubricant to uppermost end of cable. Leave in vertical position until lubricant appears at bottom end. Allow excess to drain and reinstall.

Recommended lubricant:

Yamaha chain and cable lube or SAE 10W/30 motor oil

SWING ARM

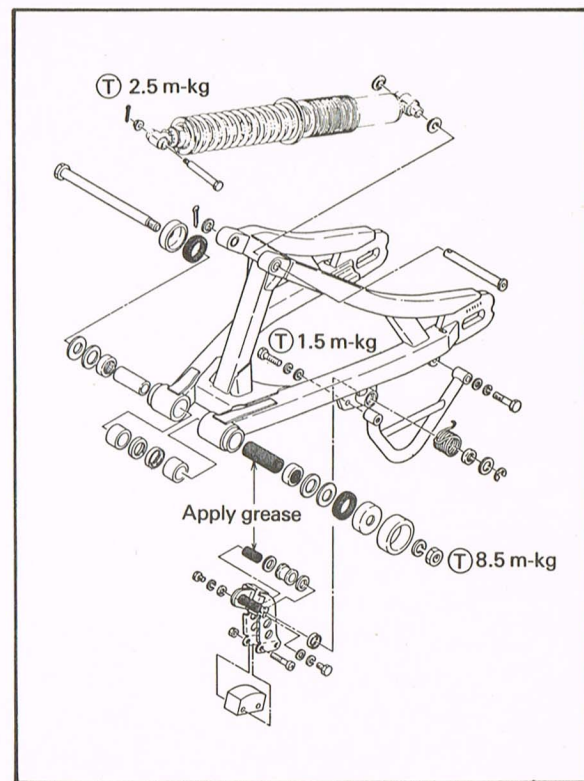

REAR SHOCK ABSORBER

Removal:

1. Remove the two bolt holding the fuel tank (petcock lever must be placed in OFF). Lift up the front of the tank and remove it.
2. Place a proper size wooden box or a frame stand under the engine to keep the rear wheel raised off the floor.
3. Remove the cotter pin and nut. And remove the bolt securing the upper bracket to frame.

Upper bracket tightening torque:
2.5 m·kg

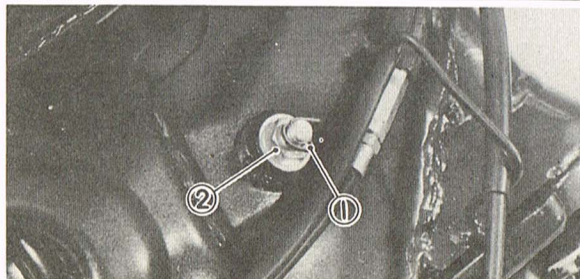

1. Cotter pin 2. Nut

4. Remove the cotter pin and pull out the pivot shaft from the lower bracket.

NOTE:

Always use a new cotter pin.

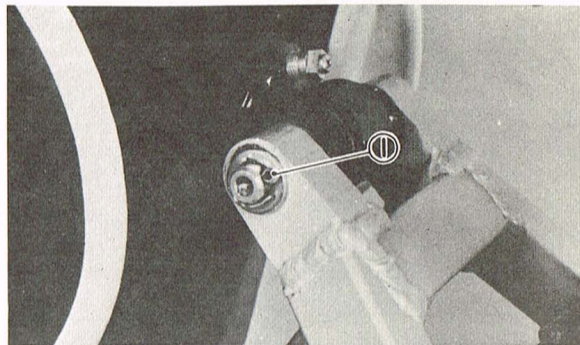

1. Cotter pin

5. Remove the rear shock absorber from the frame. (To remove, pull the rear shock backward.)

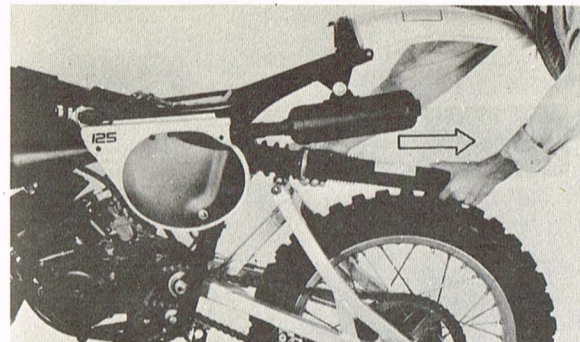

NOTE:

- a. When remove the shock absorber, be careful not to bend the absorber rod.
- b. Take care so the two washers are not lost.

Swing arm inspection

1. With rear wheel and shock absorbers removed, grasp the ends of the arm and move from right to left to check for freeplay.

Swing arm freeplay:

0 ~ 1 mm (0 ~ 0.04 in)

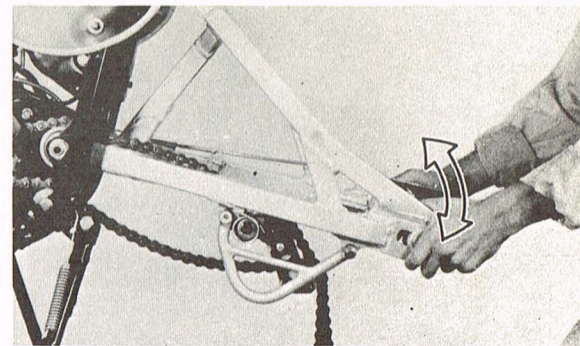

2. If freeplay is excessive, remove swing arm and replace swing arm bearings and bushing.

CABLE ROUTING DIAGRAM

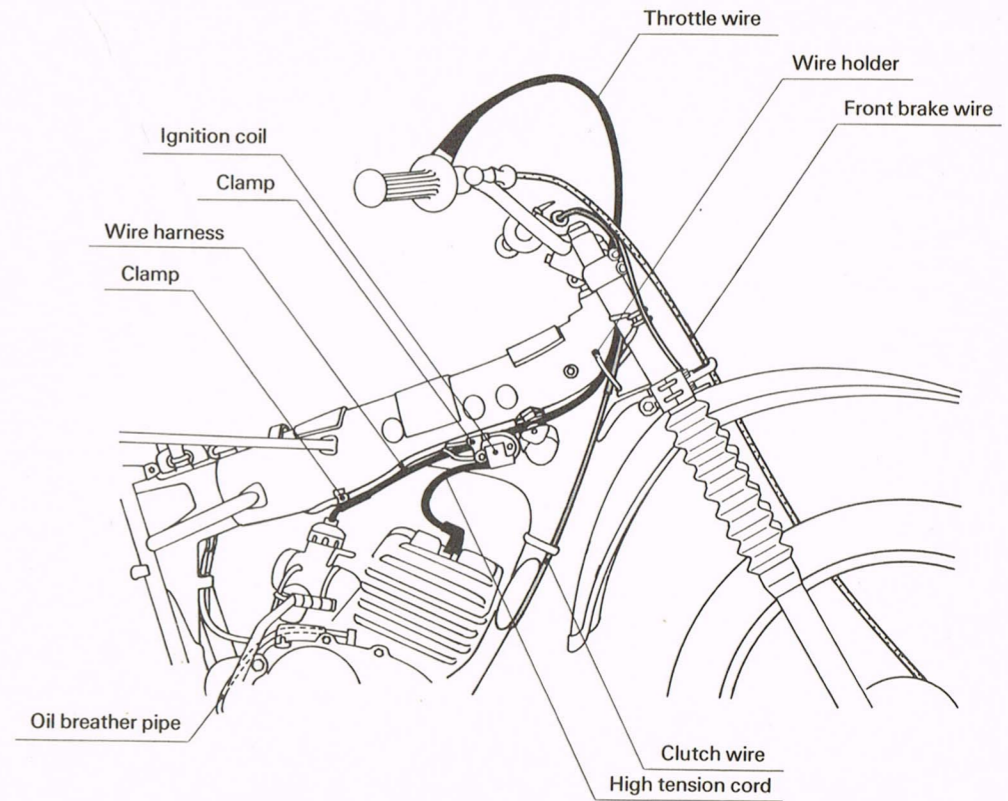
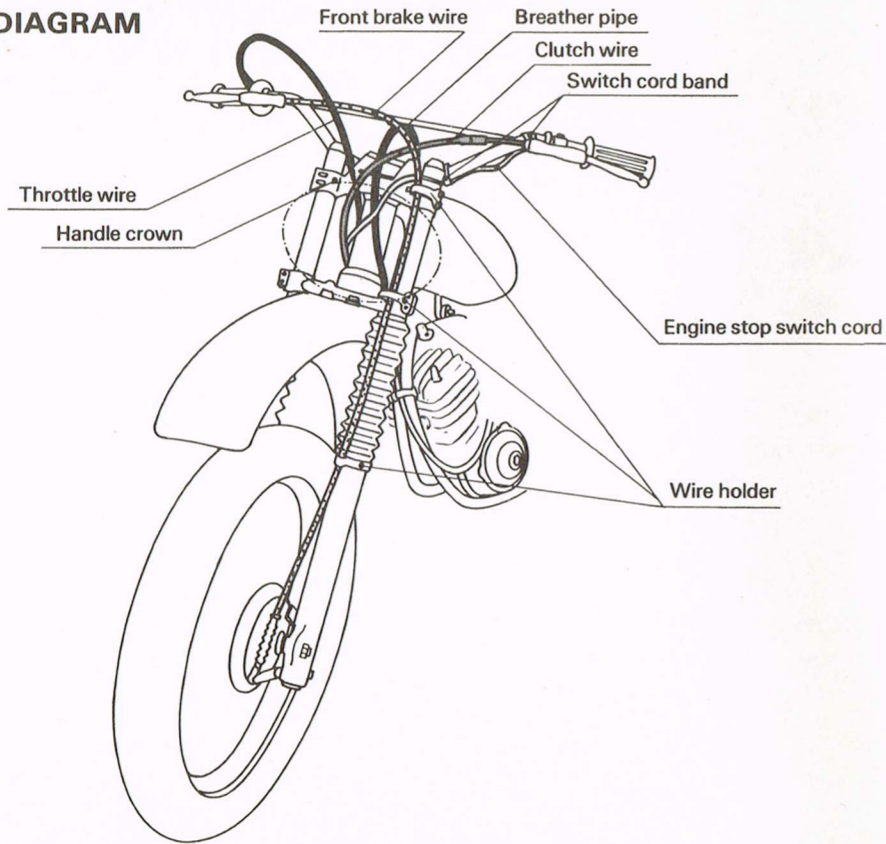

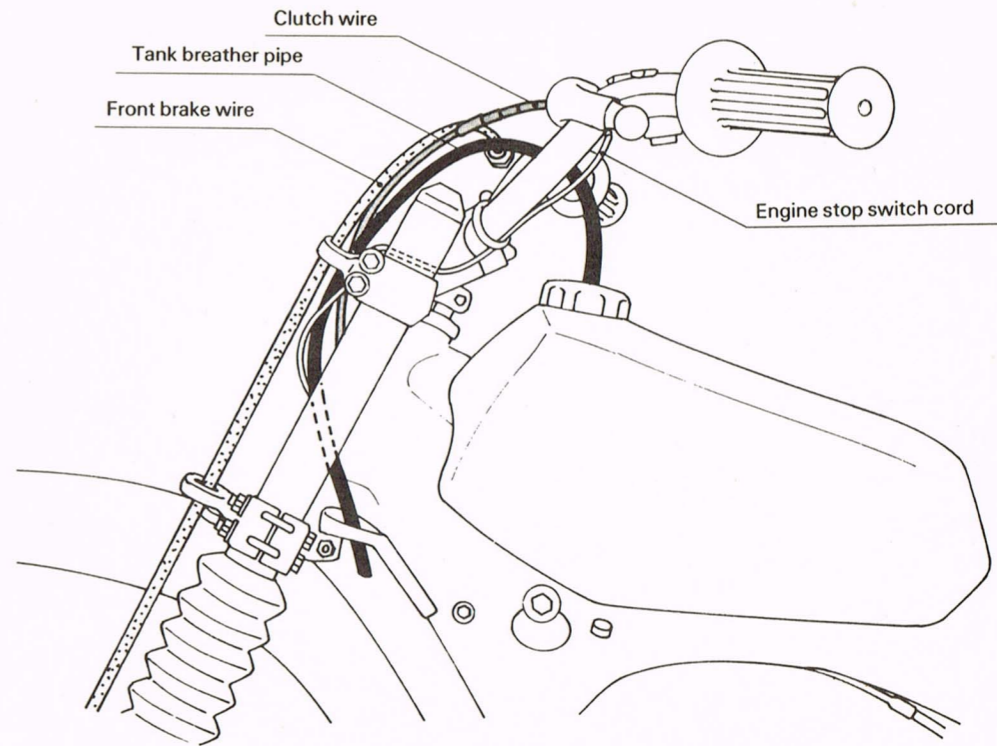
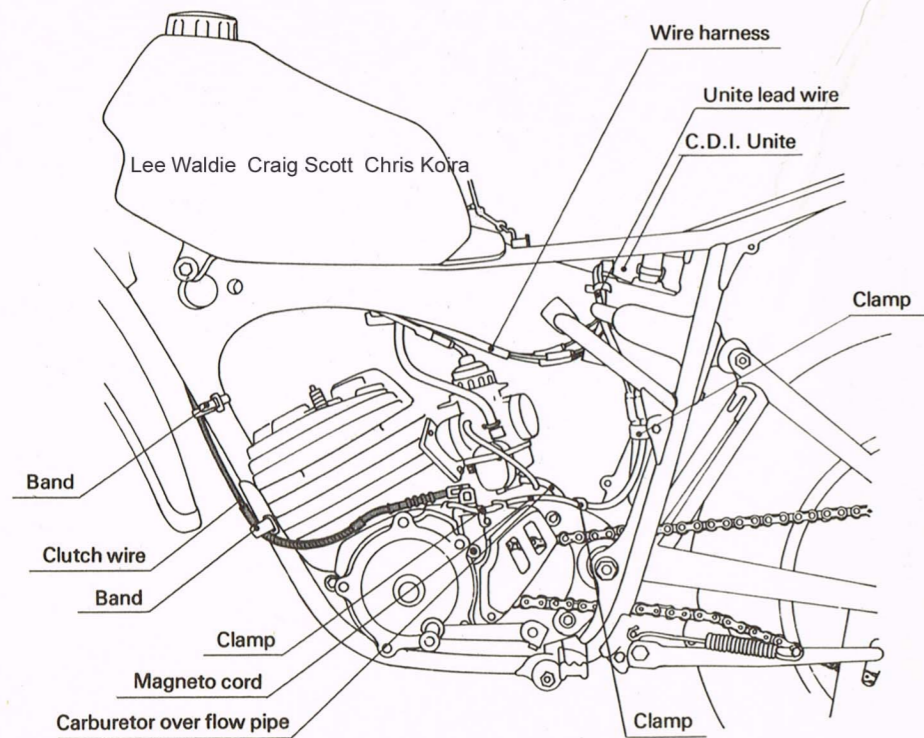

IGNITION

Wiring Diagram:

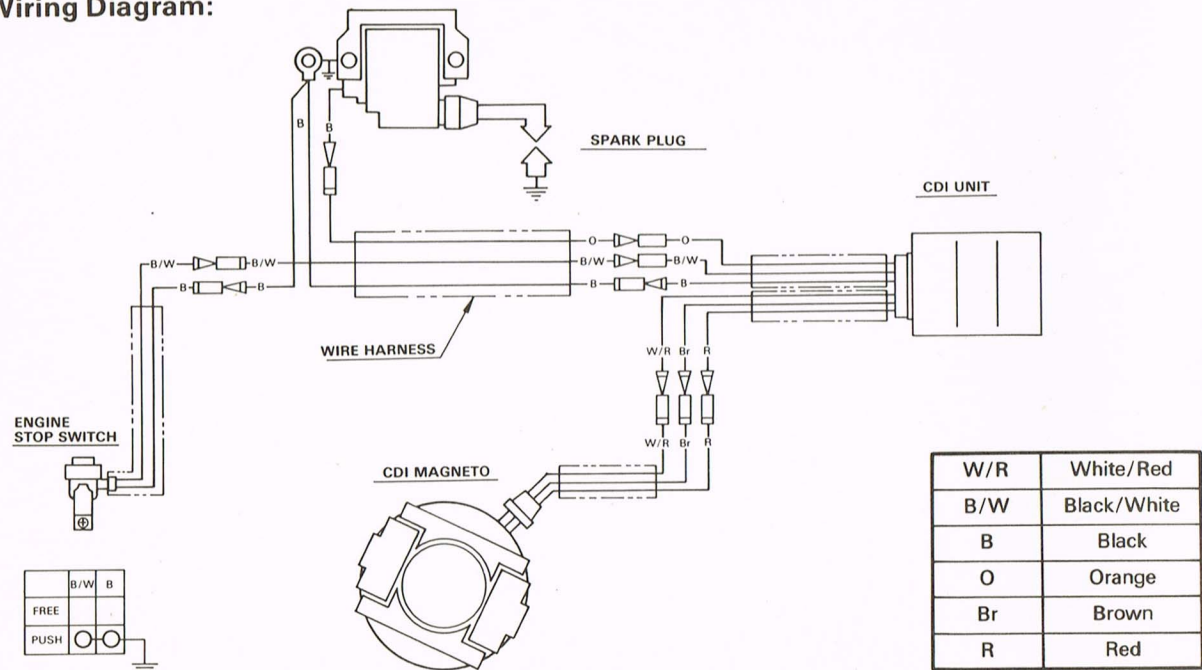

Troubleshooting:

1. No spark is produced or weak.

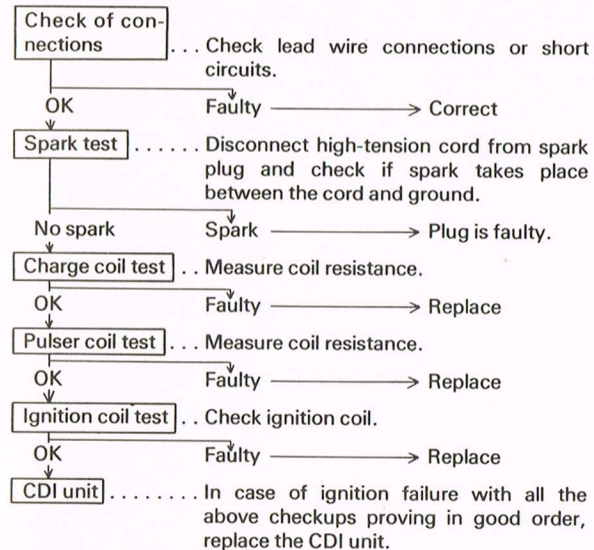

2. The engine starts but will not pick up speed.

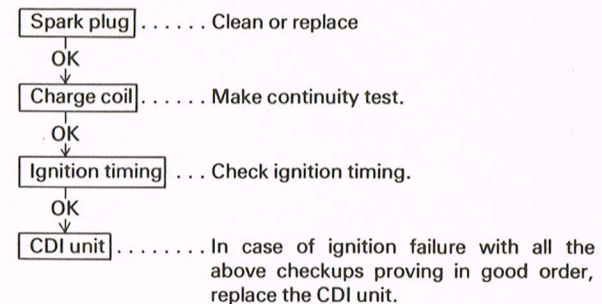

SPECIFICATIONS

A. General

Dimensions:	
Overall length	2,100 mm (82.7 in)
Overall width (Standard)	900 mm (35.4 in)
Overall height (Standard)	1,180 mm (46.5 in)
Seat height	905 mm (35.6 in)
Wheelbase	1,420 mm (55.9 in)
Minimum ground clearance	295 mm (11.6 in)
Weight:	
Net weight	86 kg (190 lb)

B. Engine

Description:	
Engine type	Air cooled, 2-stroke, gasoline, Torque induction system
Engine model	2K6
Displacement	123 cc (7.52 cu. in)
Bore × stroke	56 × 50 mm (2.20 × 1.97 in)
Compression ratio	7.4 : 1
Starting system	Primary kick starter
Ignition system	CDI magneto
Lubrication system	Mixed gas 20 : 1

Cylinder head:	
Combustion chamber volume	11.3 cc (0.69 cu. in)
Combustion chamber type	Dome + squish
Head gasket thickness	0.5 mm (0.02 in)
Cylinder:	
Material	Aluminum alloy with cast iron sleeve
Bore size	56.000 — 56.020 mm (2.204 — 2.205 in)
Taper limit	0.05 mm
Out of round limit	0.01 mm
Piston:	
Piston skirt clearance	0.045 — 0.050 mm
Piston measuring point	18 mm (0.7 in) from bottom of piston skirts
Piston over size	56.25 mm, 56.50 mm, 56.75 mm, 57.00 mm
Piston pin outside diameter × length	16 × 47 mm (0.63 × 1.85 in)
Piston rings:	
Ring design	Plain
Ring end gap	0.3 — 0.5 mm (0.012 — 0.019 in)
Ring groove side clearance 1st	0.04 — 0.08 mm (0.0016 — 0.003 in)
Connecting rod bearing: 2nd	0.03 — 0.07 mm (0.0012 — 0.0028 in)
Type	Needle bearing
Crankshaft:	
Assembly width (B)	55.90 — 55.95 mm (2.20 — 2.203 in)
Deflection (A)	0.03 mm
Big end side clearance (D)	0.2 — 0.7 mm (0.008 — 0.028 in)

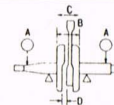

Small end deflection (C) Crank bearing type (L) (R) Crank oil seal type (L) (R)	0.8 — 1.0 mm (Maximum 2.0 mm) 6205 C4SH 6305 C3SH MHSA 25 × 40 × 8 MHSD 28 × 40 × 8
Clutch: Type Clutch push system Primary reduction ratio, method Friction plate — Thickness/Quantity — Wear limit Clutch plate — Thickness/Quantity — Warp limit Clutch spring — Free length/Quantity — Wear limit Clutch housing axial play Push rod bending limit	Wet, multiple disc type Inner push type, cam axle 71/22 (3.227), Helical gear 3.0 mm (0.12 in) × 6 pcs 2.7 mm (0.11 in) 1.2 mm (0.047 in) × 5 pcs 0.05 mm 36.0 mm (1.427 in) × 5 pcs 35.00 mm (1.38 in) 0.05 — 0.13 mm 0.15 mm (0.006 in)
Transmission: Type Gear ratio 1st (Teeth, Ratio) 2nd 3rd 4th 5th 6th	Constant mesh, 6 speed forward 32/13, 2.461 30/16, 1.875 27/18, 1.500 25/20, 1.250 24/22, 1.090 23/23, 1.000

Gear oil quantity (Periodic change) (Overhaul) Gear oil grade Secondary reduction ratio, method	600 — 700 cc (36.6 — 42.7 cu. in) 700 — 800 cc (42.7 — 48.8 cu. in) SAE 10W/30 "SE" motor oil 51/12, 4.250 Chain
Shifting mechanism: Type Pattern	Guide bar 1-N-2-3-4-5-6
Intake: Air cleaner — Type — Oil grade Induction system	Wet foam rubber × 1 pcs Air cooled 2-stroke engine oil Reed valve
Reed valve: Type Bending limit Valve lift	V Type 0.3 mm (0.012 in) 8.1 — 8.5 mm (0.32 — 0.33 in)
Carburetor: Type/Manufacture I.D. mark Main jet (M.J.) Air jet (A.J.) Jet needle-Clip position (J.N.) Needle jet (N.J.) Cutaway (C.A.) Pilot jet (P.J.) Air screw turns out (A.S.) Starter jet (G.S.) Float arm height (F.H.)	VM32SS/MIKUNI 2K6 00 #280 2.0 6F22-3 P-8 3.0 60 1-3/4 80 23.5 mm (0.925 in)

C. Chassis

Frame design: Steering System: Caster Trail Lock to lock angle Head pipe bearing type	CHROME MOLYBDENUM ALLOY STEEL TUBULAR , semi double cradle 30° 133 mm (5.2 in) 92° Taper roller bearing
Front suspension: Type Damper construction Front fork travel Front fork spring — Free length — Wire Dia. × — Winding Dia. — Spring constant Inner tube outside diameter Oil seal type Oil quantity/Grade Air pressure	Telescopic fork Coil spring and air/oil damper 230 mm (9.1 in) 513 mm (20.19 in) 3.8 mm × 29 mm (0.14 in × 1.14 in) K = 0.255 36 mm (1.42 in) SD 36-48-10.5 283 cc (9.57 oz) / SAE #15 0.98 kg/cm²
Rear suspension: Type Damper construction Gas properties Gas pressure Absorber stroke Wheel travel	Monocross Coil spring, Gas/oil damper Nitrogen gas 15 kg/cm² 134 mm (5.3 in) 240 mm (9.45 in)

Compression spring — Free length — Set length — Spring constant — Number of windings — Spring diameter — Spring winding D. Swing arm free play	304 mm (11.9 in) 287 mm (11.3 in) K1 = 2.31, K2 = 4.01 13.75 turns 9.8 mm (0.39 in) 74.6 mm (2.9 in) 0 — 1 mm
Fuel tank: Capacity Fuel grade	5.8 lit Mixed Gas 20 : 1 (Premium gasoline: Yamalube "R")
Wheel: Tire size (F) (R) Tire pressure (F) (R) Rim size (F) (R) Rim runout limit (F, R) Vertical Lateral	3.00—21—4PR/Inoue 4.10—18—4PR/Inoue 1.0 kg/cm (14 psi) 1.2 kg/cm (17 psi) 1.60 — 21 1.85 — 18 2 mm (0.08 in) 2 mm (0.08 in)
Secondary drive: Type Number of links Chain free play	Chain/DID520TR 103 55 — 60 mm (2.17 — 2.36 in)

Brake:	
Type	Leading, trailing
Drum diameter (F)/(R)	130 mm (5.12 in)
Shoe diameter × Width (F)	130 × 22 mm (5.12 × 0.87 in)
(R)	130 × 28 mm (5.12 × 1.10 in)
Lining thickness (Wear limit)	4 mm/2 mm (0.16 in/0.08 in)
Shoe spring free length (F)/(R)	35 mm (1.38 in)

D. Electrical

Ignition system:	
Type	CDI magneto (Inner rotor)
Model/Manufacture	M100-20/Hitachi
Source coil resistance	500 Ω ± 15 % at 20°C
Pulser coil resistance	85 Ω ± 15 % at 20°C
Rotor puller thread size	20 mm (0.78 in)
Ignition timing: (B.T.D.C.)	1.2 mm (1.05 — 1.35 mm) 0.047 in (0.04 — 0.053 in)
Ignition coil.	
Model/Manufacture	CM61-20/Hitachi
Spark gap	6 mm (0.24 in) or more
Primary winding resistance	0.60 Ω at 20°C
Secondary winding resistance	6.0 kΩ at 20°C
Spark plug:	
Type/Manufacture	N-59G/Champion
Spark plug gap	0.7 mm (0.028 in)

CDI unit:	
Type/Manufacture	TIA 01-16/Hitachi Lee Waldie Craig Scott Chris Koira

E. Tightening torque

Engine:		
Cylinder head	— Nut	M8 2.5 m-kG (18 ft-lb)
	— Stud bolt	M8 2.5 m-kG (18 ft-lb)
Cylinder	— Nut	M10 3.8 m-kG (27 ft-lb)
	— Stud bolt	M10 4.5 m-kG (32 ft-lb)
Spark plug		M14 2.5 m-kG (18 ft-lb)
Primary drive gear		M12 6.0 m-kG (43 ft-lb)
Clutch boss		M14 5.0 m-kG (36 ft-lb)
Clutch spring		M5 0.6 m-kG (4 ft-lb)
Drive sprocket		M16 5.5 m-kG (40 ft-lb)
Kick crank		M8 1.5 m-kG (11 ft-lb)
Change pedal		M6 1.0 m-kG (7 ft-lb)
Reed valve		M3 0.07 m-kG (0.5 ft-lb)
CDI rotor		M12 5.5 m-kG (40 ft-lb)
Starter		M6 0.7 m-kG (5 ft-lb)
Exhaust pipe		M6 1.0 m-kG (7 ft-lb)
Chassis:		
Engine mounting bolt		M8 2.5 m-kG (18 ft-lb)
		M10 4.0 m-kG (29 ft-lb)

Handle crown	— Steering shaft (Pinch bolt)	M8	1.5 m-kg (11 ft-lb)
	— Steering shaft (Stem bolt)	M14	5.5 m-kg (40 ft-lb)
Front fork	— Inner tube	M10	1.5 m-kg (11 ft-lb)
	— Handle holder	M8	1.5 m-kg (11 ft-lb)
	— Cap bolt	M26	2.0 m-kg (15 ft-lb)
Under bracket	— Damper unit	M10	2.0 m-kg (15 ft-lb)
	— Inner tube	M8	2.5 m-kg (18 ft-lb)
	— Steering shaft	M10	2.0 m-kg (15 ft-lb)
Rear shock absorber	— Frame	M8	2.5 m-kg (18 ft-lb)
Pivot shaft		M16	8.5 m-kg (61 ft-lb)
Front wheel axle		M14	8.5 m-kg (61 ft-lb)
Rear wheel axle		M14	8.5 m-kg (61 ft-lb)
Sprocket wheel		M10	4.0 m-kg (29 ft-lb)

CONVERSION TABLES

Metric to Inch System		
KNOWN	MULTIPLIER (Rounded off)	
TORQUE		
m-kg	7.233	ft-lb
m-kg	86.80	in-lb
cm-kg	0.0723	ft-lb
cm-kg	0.8680	in-lb
WEIGHT		
kg	2.205	lb
g	0.0353	oz
FLOW/DISTANCE		
km/lit	2.352	mpg
km/h	0.6214	mph
km	0.6214	mi
m	3.2809	ft
m	1.0936	yd
cm	0.3937	in
mm	0.03937	in
VOLUME/CAPACITY		
cc	0.03381	oz (U.S. liq)
cc	0.06103	cu. in
lit	2.1134	pt (U.S. liq)
lit	1.057	qt (U.S. liq)
lit	0.2642	gal (U.S. liq)
MISC		
kg/mm	55.9970	lb/in
kg/cm ²	14.2233	psi (lb/in ²)
Centigrade (°C)	9/5 (°C) + 32	Fahrenheit (°F)

DEFINITION OF TERMS:

m-kg — Meter-kilogram: Usually torque. g — Gram.
 kg — Kilogram: 1,000 grams.
 km — Kilometer. lit — Liter: 1,000 cm³

Inch to Metric System		
KNOWN	MULTIPLIER (Rounded off)	RESULT
TORQUE		
ft-lb	0.1383	m-kg
ft-lb	13.8313	cm-kg
in-lb	0.01152	m-kg
in-lb	1.1522	cm-kg
WEIGHT		
lb	0.4536	kg
oz	28.3286	g
FLOW/DISTANCE		
mi/gal	0.4252	km/lit
mi/h	1.6093	km/h
mi	1.6093	km
ft	0.3048	m
yd	0.9144	m
in	2.540	cm
in	25.40	mm
VOLUME/CAPACITY		
oz (U.S. liq)	29.577	cc
cu.in	16.385	cc
pt (U.S. liq)	0.4732	lit
qt (U.S. liq)	0.9461	lit
gal (U.S. liq)	3.7850	lit
MISC		
lb/in	0.01786	kg/mm
psi (lb/in ²)	0.07031	kg/cm ²
Fahrenheit (°F)	5/9 (°F-32)	Centigrade (°C)

cm³ — Cubic centimeter: Volume or capacity.
 km/lit — Kilometer per liter: Mileage.
 kg/mm — Kilogram per millimeter: Usually spring
 compression rate.
 —78— kg/cm² — Kilogram per square centimeter: Pressure.

CLEANING AND STORAGE

Cleaning

Frequent thorough cleaning of your motorcycle will not only enhance its appearance, but will improve general performance and extend the useful life of many components.

1. Before cleaning the machine:
Block entry; a plastic bag and strong rubber band may be used.
2. If engine case is excessively greasy, apply degreaser with a paint brush. Do not apply degreaser to chain, sprockets, or wheel axles.
3. Rinse dirt and degreaser off with garden hose, using only enough hose pressure to do the job. Excessive hose pressure may cause water seepage and contamination of wheel bearings, front forks, brake drums, and transmission seals. Many expensive repair bills will result from improper high-pressure

detergent applications such as those available in coin-operated car washes.

4. Once the majority of dirt has been hosed off, wash all surfaces with warm water and mild detergent-type soap. An old toothbrush or bottle brush is handy to reach those hard-to-get-to places.
5. Rinse machine off immediately with clean water and dry all surfaces with a chamois skin, clean towel, or soft absorbent cloth.
6. Immediately after washing, remove excess moisture from chain and lubricate to prevent rust.
7. Clean the seat with a vinyl upholstery cleaner to keep the cover pliable and glossy.
8. Automotive-type wax may be applied to all painted and chrome-plated surfaces. Avoid combination cleaner-waxes. Many contain abrasives which may mar paint or protective finish.

9. After finishing, start the engine immediately and allow to idle for several minutes.

Storage

Long term storage (30 days or more) of your motorcycle will require some preventive procedures to insure against deterioration. After cleaning machine thoroughly, prepare for storage as follows:

1. Drain fuel tank, fuel lines, and carburetor float bowl.
2. Remove spark plug, pour about one tablespoon of 10W to 30W oil in spark plug hole and reinstall spark plug. Kick engine over several times (with ignition off) to coat cylinder wall with oil.

3. Remove drive chain. Clean thoroughly with solvent and lubricate with graphite-base chain lubricant. Re-install chain or store in a plastic bag (tie to frame for safe-keeping).
4. Lubricate all control cables.
5. Block up frame to raise both wheels off ground.
6. Deflate tires to 12 lb/in² (0.8 kg/cm²)
7. Tie a plastic bag over exhaust pipe outlet to prevent moisture entering.
8. If storing in humid or salt-air atmosphere,, coat all exposed metal surfaces with a light film of oil. Do not apply oil to rubber parts or seat cover.

WARRANTY INFORMATION

STATEMENT OF PURCHASER'S RESPONSIBILITY

This (model) Yamaha motorcycle is sold AS IS, WITHOUT ANY WARRANTIES EXPRESSED OR IMPLIED REGARDLESS OF THE INTENDED USE.

THE PURCHASER OF THIS MOTORCYCLE, which is intended for competition purposes, IS RESPONSIBLE FOR ALL COSTS OF SERVICE AND/OR REPAIR.

Lee Waldie Craig Scott Chris Koirra