

002094



YAMAHA

IT490K / IT250K

**OWNER'S MANUAL
AND SERVICE**

INDEX

GENERAL INFORMATION

1

**REGULAR MAINTENANCE
AND ADJUSTMENTS**

2

**ENGINE MAINTENANCE AND
REPAIR**

3

**CHASSIS MAINTENANCE
AND REPAIR**

4

**ELECTRICAL
TROUBLESHOOTING**

5

APPENDICES

6

1 GENERAL INFORMATION

MACHINE IDENTIFICATION

There are two significant reasons for knowing the serial number of your machine:

1. When ordering parts, you can give the number to your Yamaha dealer for positive identification of the model you own;
2. If your bike is stolen, the authorities will need the number to search for and identify your machine.

Frame serial number

The frame serial number is stamped on the right of the steering head pipe.

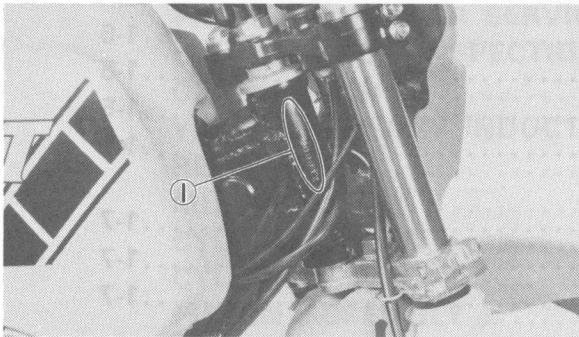

1. Frame serial number

Engine serial number

The engine serial number is stamped into the elevated part of the right rear section of the engine.

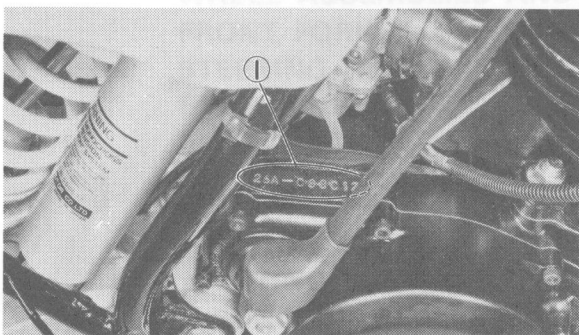

1. Engine serial number

CONTROL FUNCTIONS

Note on handling of the Yamaha Energy Induction System

Handle the air chamber and hose with special care. Improper installation or damaged parts will result in poor performance. Replace any cracked or damaged parts immediately. No modification of this system in any form is not allowed.

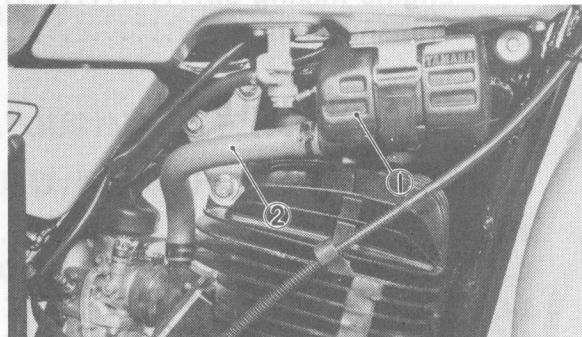

1. Air chamber 2. Hose

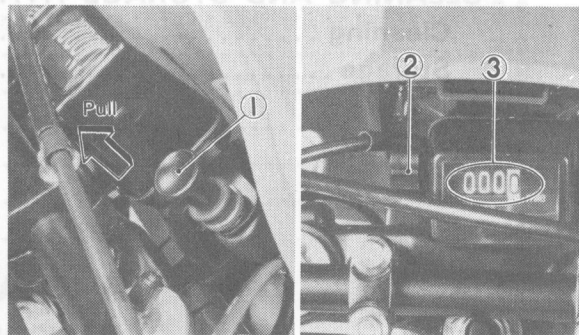

1. Lighting switch
When the lighting switch is pulled up, both headlight and taillight come on.
2. Reset knob
To change the meter reading pull the knob and turn it as required.
3. Trip-odometer

APPENDICES	8-1
TROUBLESHOOTING GUIDE	8-1
SPECIFICATIONS	8-9
CONVERSION TABLES	8-13
DEFINITION OF UNITS	8-13
CABLE ROUTING DIAGRAM	8-14
WARRANTY INFORMATION	8-15

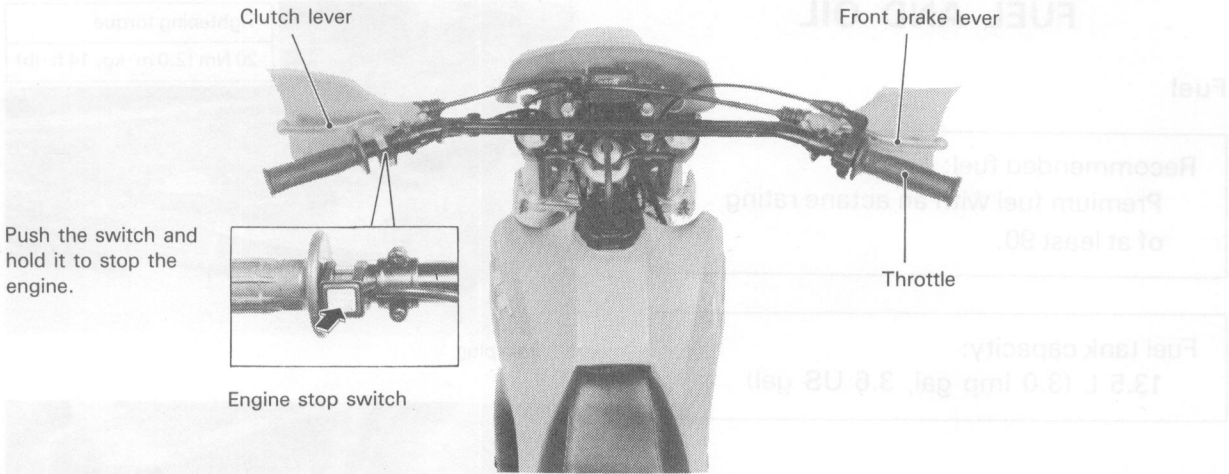

Fuel cock
OFF: Fuel will not flow. Always return the lever to this position when the engine is not running.
ON: Fuel flow to the carburetor. Normal riding is done with the lever in this position.
RES: This indicates "RESERVE". If you run out of fuel while riding, move the lever to this position. THEN, FILL THE TANK AT THE FIRST OPPORTUNITY.

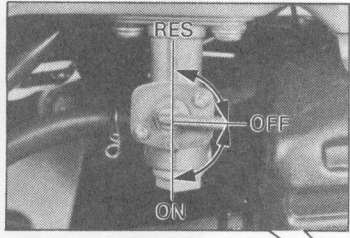

Starter lever

When cold, the engine requires richer fuel mixture for starting. Push the lever down to open the circuit (for starting) and pull it up to close the circuit before riding. Never ride the machine with the starter lever down.

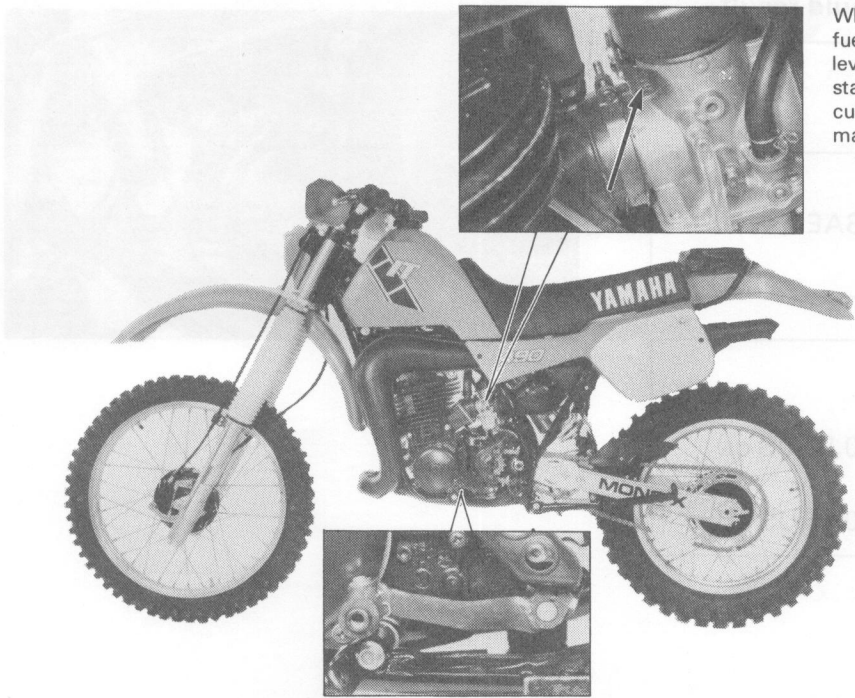

Shift pedal

FUEL AND OIL

Fuel

Recommended fuel:
Premium fuel with an octane rating
of at least 90.

Fuel tank capacity:
13.5 L (3.0 Imp gal, 3.6 US gal)

Engine mixing oil

Recommended oil: Yamalube "R"
(Yamalube Racing 2-cycle oil)
Mixing ratio: 24 : 1

If for any reason you should use another
type, select from the following list.

Mixing ratio: 20 : 1
*Castrol R30
*Castrol A545

CAUTION:

Never mix two types of oil in the same
batch; clotting of the oil could result.

Transmission oil

Recommended oil:
Yamalube 4-cycle oil or SAE
10W30 SE motor oil

Transmission oil capacity:
Periodic oil change:
750 cm³ (0.66 Imp qt, 0.80 US qt)
Overhaul:
800 cm³ (0.70 Imp qt, 0.85 US qt)

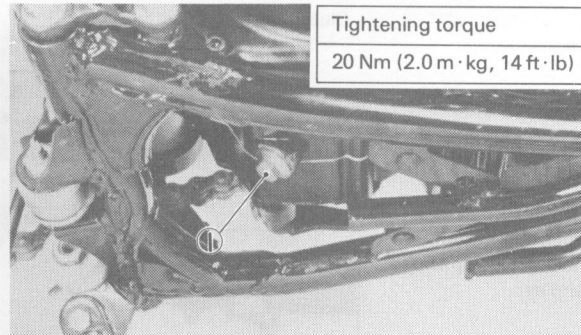

1. Drain plug

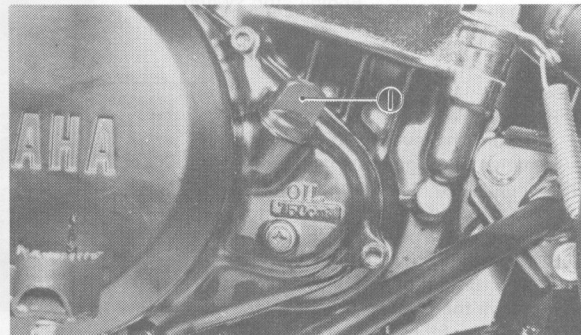

1. Filler plug

CHECKING OIL LEVEL

On the right side of the engine there is a
checking screw. To check, warm up the
engine for 1 minute. Stop engine. Leave the
engine as it is for a few minutes and place the
machine screw. If oil flows out, the oil level is
correct.

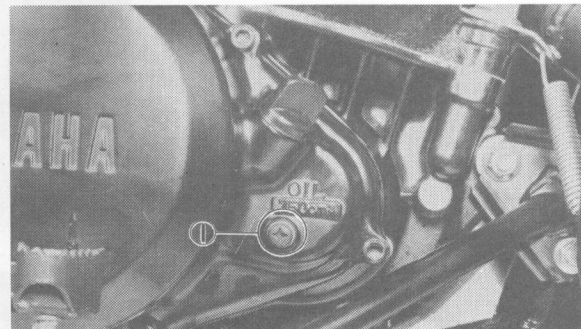

1. Checking screw

PREOPERATION CHECKS

Before riding for break-in operation, practice or a race, make sure the machine is in good operating condition.

INSPECTION AND MAINTENANCE

Fuel

Check that a fresh mixture of oil and gasoline is filled in the fuel tank.

Gear oil

Check that the gear oil level is correct.

Gear shifter and clutch

Check that gears can be shifted correctly in order and that the clutch operates smoothly.

Brakes

Check the play of both front and rear brakes and their braking effect.

Chain

Check chain tension and alignment. Check that the chain is lubricated properly.

Wheels

Is the tire pressure correct?

Check for excessive wear. Check for loose spokes or wheel runout.

Steering

Check that the handlebars can be turned smoothly and have no excessive play.

Front forks and rear shock

Check that they operate smoothly and there is no oil leakage.

*The machine should be checked and serviced regularly so that only a simple, minor adjustment of settings is required prior to a race.

Cables (Wires)

Check that the clutch, brake and throttle cables move smoothly.

Check that they are not caught when the handlebars are turned or when the front forks travel up and down.

Muffler

Check that the muffler is tightly mounted and has no cracks.

Sprocket

Check that the rear wheel sprocket tightening bolt is not loose.

Bolts and nuts

Check the chassis and engine for loose bolts and nuts.

Fuel and oil

Check the fuel tank, fuel cock, carburetor, and engine bottom for leakage.

Lead wire connectors

Check that the CDI magneto, CDI unit, and ignition coil are connected tightly.

Settings

Is the machine set suitably for the condition of the racing course and weather or by taking into account the results of test-runs before racing? Is inspection and maintenance completely done?

STARTING AND BREAK-IN

CAUTION:

Before starting the machine, perform the checks in the preoperation check list.

WARNING:

Never start or run the engine in a closed area. The exhaust fumes are poisonous; they can cause loss of consciousness and death in a very short time. Always operate the machine in a well-ventilated area.

Starting a cold engine

Shift the transmission into neutral. Turn on the fuel petcock and raise the starter knob on the carburetor. With the throttle completely closed, kickstart the engine with a smooth, firm stroke. Using the starter knob as required, run the engine at idle or slightly higher until it warms up; this usually takes about one or two minutes. The engine is warmed up when it responds normally to the throttle with the starter knob pushed completely down.

CAUTION:

Do not warm up the engine for extended periods.

Starting a warm engine

Do not raise the starter knob. Open the throttle slightly and kickstart the engine with a smooth, firm stroke.

CAUTION:

Observe the following break-in procedures during initial operation to ensure optimum performance and avoid engine damage.

Break-in procedures

1. Before starting the engine, fill the fuel tank with a break-in oil-fuel mixture of 12 : 1 to 14 : 1.
2. Perform the preoperation checks on the machine.
3. Start and warm up the engine. Check the idle speed, and check the operation of the controls and the engine stop switch.
4. Operate the machine in the lower gears at moderate throttle openings for five to eight minutes. Stop and check the spark plug condition; it will show a rich condition during break-in.
5. Allow the engine to cool. Restart the engine and operate the machine as in the step above for five minutes. Then, very briefly shift to the higher gears and check full-throttle response. Stop and check the spark plug.
6. After again allowing the engine to cool, restart and run the machine for five more minutes. Full throttle and the higher gears may be used, but sustained full-throttle operation should be avoided. Check the spark plug condition.
7. Allow the engine to cool, remove the top end, and inspect the piston and cylinder; instructions for this are on page 4-8. Remove any high spots on the piston with 600-grit, wet sandpaper. Clean all components and carefully reassemble the top end.
8. Drain the break-in oil-fuel mixture from the fuel tank and refill with the specified mix. Check the entire machine for loose screws, bolts, and nuts.
9. Restart the engine and check the operation of the machine throughout its entire operating range. Stop and check the spark plug condition. Restart the machine and operate it for about 10 to 15 more minutes. The machine will now be ready to race.

CAUTION:

1. After the break-in period is completed, check the entire machine for loose fittings and fasteners. Tighten all such fasteners as required.
2. When any of the following parts have been replaced, they must be broken in.

CYLINDER AND CRANKSHAFT:

About one hour of break-in operation is necessary.

PISTON, RINGS, GEARS:

These parts require about 30 minutes of break-in operation at half-throttle or less. Observe the condition of the engine carefully during operation.

Storage

CLEANING AND STORAGE

Cleaning
Frequent cleaning of your machine will enhance its appearance, maintain good overall performance, and extend the life of many components.

1. Before washing the machine, block off the end of the exhaust pipe to prevent water from entering. A plastic bag secured with a rubber band may be used for this purpose.
2. If the engine is excessively greasy, apply some degreaser to it with a paint brush. Do not apply degreaser to the chain, sprockets, or wheel axle.
3. Rinse the dirt and degreaser off with a garden hose; use only enough pressure to do the job.

CAUTION:

Excessive hose pressure can force water into wheel bearings, front fork seals, brake drums, and transmission seals. Avoid using high-pressure hoses such as those found in coin-operated car washes.

4. After the majority of the dirt has been hosed off, wash all surfaces with warm water and a mild detergent. Use an old toothbrush to clean hard-to-reach places.
5. Rinse the machine off immediately with clean water, and dry all surfaces with a soft towel or cloth.
6. Immediately after washing, remove excess water from the chain with a paper towel and lubricate the chain to prevent rust.
7. Clean the seat with a vinyl upholstery cleaner to keep the cover pliable and glossy.
8. Automotive wax may be applied to all painted or chromed surfaces. Avoid combination cleaner-waxes, as they may contain abrasives.
9. After completing the above, start the engine and allow it to idle for several minutes.

NOTE:

Make any necessary repairs before the machine is stored.

CLEANING AND STORAGE

Cleaning

Frequent cleaning of your machine will enhance its appearance, maintain good overall performance, and extend the life of many components.

1. Before washing the machine, block off the end of the exhaust pipe to prevent water from entering. A plastic bag secured with a rubber band may be used for this purpose.
2. If the engine is excessively greasy, apply some degreaser to it with a paint brush. Do not apply degreaser to the chain, sprockets, or wheel axles.
3. Rinse the dirt and degreaser off with a garden hose; use only enough pressure to do the job.

CAUTION:

Excessive hose pressure can force water into wheel bearings, front fork seals, brake drums, and transmission seals. Avoid using high-pressure hoses such as those found in coin-operated car washes.

4. After the majority of the dirt has been hosed off, wash all surfaces with warm water and a mild detergent. Use an old toothbrush to clean hard-to-reach places.
5. Rinse the machine off immediately with clean water, and dry all surfaces with a soft towel or cloth.
6. Immediately after washing, remove excess water from the chain with a paper towel and lubricate the chain to prevent rust.
7. Clean the seat with a vinyl upholstery cleaner to keep the cover pliable and glossy.
8. Automotive wax may be applied to all painted or chromed surfaces. Avoid combination cleaner-waxes, as they may contain abrasives.
9. After completing the above, start the engine and allow it to idle for several minutes.

Storage

If your machine is to be stored for 60 days or more, some preventive measures must be taken to avoid deterioration. After cleaning the machine thoroughly, prepare it for storage as follows:

1. Drain the fuel tank, fuel lines, and the carburetor float bowl.
2. Remove the spark plug, pour a tablespoon of SAE 10W/30 motor oil in the spark plug hole, and reinstall the plug. With the engine stop switch pushed in, kick the engine over several times to coat the cylinder walls with oil.
3. Remove the drive chain, clean it thoroughly with solvent, and lubricate it. Reinstall the chain or store it in a plastic bag tied to the frame.
4. Lubricate all control cables.
5. Block the frame up to raise the wheels off the ground.
6. Tie a plastic bag over the exhaust pipe outlet to prevent moisture from entering.
7. If the machine is to be stored in a humid or salt-air environment, coat all exposed metal surfaces with a film of light oil. Do not apply oil to rubber parts or the seat cover.

NOTE:

Make any necessary repairs before the machine is stored.

2 REGULAR MAINTENANCE AND

ADJUSTMENT

The following schedule is intended as a general guide to maintenance and adjustment. Best in mind that such factors as weather, terrain, gear use, and rider condition may require adjustments to the regular maintenance and adjustment intervals. If you are unsure of the intervals to follow in maintaining and lubricating your machine, consult your Yamaha dealer.

MAINTENANCE INTERVALS CHART2-1

LUBRICATION2-3

SPECIAL TOOLS	2-5
Dial gauge	2-5
Dial gauge stand	2-5
Dial gauge extension	2-5
Timing light	2-5
Yamaha pocket tester	2-5
Clutch holding tool	2-5
Crankcase separating tool	2-6
Crankshaft installing tool	2-6
Spacer	2-6
Crankshaft installing bolt and adapter	2-6
Rotor holding tool	2-6
Flywheel magneto puller	2-6
Steering nut wrench	2-6
Fork cylinder holder and adapter	2-6
Fork seal and bushing service tool	2-7
Drive chain cutter	2-7
MINOR MAINTENANCE AND ADJUSTMENTS	2-8
Spark plug	2-8
Ignition timing	2-8
Checking	2-8
Adjustment	2-8
Throttle cable	2-10
Idle speed	2-10
Air filter	2-11
Clutch	2-12
Front brake	2-12
Rear brake	2-12
Drive chain	2-13
Lubrication	2-13
Free play adjustment	2-13
Wear limit	2-14
Steering head	2-14
Cleaning the fuel cock strainer	2-15



2 REGULAR MAINTENANCE AND ADJUSTMENT

MAINTENANCE INTERVALS CHART

The following schedule is intended as a general guide to maintenance and lubrication. Bear in mind that such factors as weather, terrain, geographical location, and individual usage will alter the required maintenance and lubrication intervals. If you are in doubt as to what intervals to follow in maintaining and lubricating your machine, consult your Yamaha dealer.

Item	After break-in	Every race	Every 500 km (300 miles)	Every 1,500 km (1,000 miles)	As required	Remarks
PISTON Inspect and clean Replace	●	●		●	●	Inspect crack Remove carbon
PISTON RINGS Inspect Replace	●	●	●		●	Check ring end gap
PISTON PIN, SMALL END BEARING Inspect Replace				●	●	
CYLINDER HEAD Inspect and clean Retighten	● ●	● ●				Remove carbon
CYLINDER Inspect and clean Replace	●	●			●	seizure wear
Y.E.I.S. Inspect	●	●				
AIR FILTER Clean and oil Replace	●	●			●	Use Foam air-filter oil
CLUTCH Inspect and adjust Replace	●	●			●	Inspect friction plate, clutch plate and spring
TRANSMISSION Replace oil Inspect transmission	●			●	●	Yamalube 4-cycle oil or SAE 10W30 SE motor oil
SHIFT CAM, FORK Inspect					●	Inspect wear
ROTOR NUT Retighten				●		
MUFFLER Inspect Clean	●	●		●		
CRANK Inspect and clean				●	●	
CARBURETOR Inspect, adjust and clean	●	●				
SPARK PLUG Inspect and clean Replace	●	●			●	STD plug: N-3C (IT490K) N-86 (IT250K)

Item	After break-in	Every race	Every 500 km (300 miles)	Every 1,500 km (1,000 miles)	As required	Remarks
DRIVE CHAIN Lubricate, free play, alignment Replace	●	●			●	Use SAE 30~50 motor oil Free play: 20~30 mm (0.8~1.2 in)
OUTSIDE NUTS AND BOLTS Retighten	●	●				
FRAME Clean and inspect	●	●				
FUEL TANK, COCK Clean and inspect	●		●			
BRAKES Adjust free play Lubricate pivot point Replace linings	● ●	● ●			●	Lining wear limit: 2 mm (0.08 in)
FRONT FORKS Inspect and adjust Replace oil Replace oil seal	● ●	●		●	●	Yamaha fork oil 10 wt
REAR SHOCK Inspect and adjust lube and retighten	● ●	● ●				Lithium base grease
CHAIN GUARD AND ROLLERS Inspect and replace					●	Wear and alignment
SWINGARM Inspect, lube and retighten	●	●				Lithium base grease
RELAY ARM, TORQUE ARM Inspect and lube	●	●				Lithium base grease
STEERING HEAD Inspect free play and retighten Clean and lube Replace bearing	●	●		●	●	Medium weight wheel bearing gease
TIRE, WHEELS Inspect air pressure, wheel run-out, tire wear and spoke looseness Retighten sprocket bolt Inspect bearings Replace bearings Lubricate	● ●	● ●	● ●		●	Medium weight wheel bearing grease
THROTTLE, CONTROL CABLE Check routing and connection Lubricate	● ●	● ●				Yamaha cable lube SAE 10W30 motor oil
OUTSIDE NUTS AND BOLTS Retighten	●	●				



LUBRICATION

To ensure smooth operation of all components, lubricate your machine during setup, after break-in and after every race.

Prior to lubrication, clean parts of sand, dirt or water.

A. Use Yamaha chain and cable lube or WD-40 on these areas:

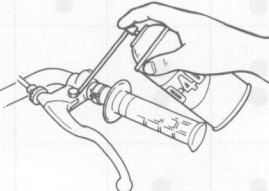
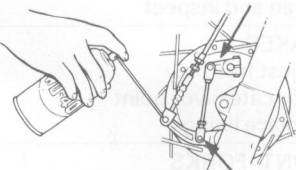
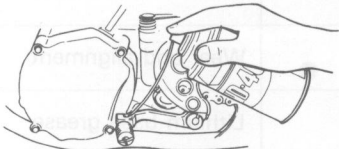
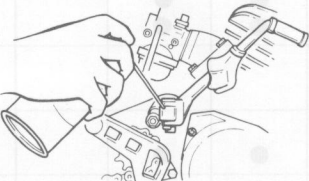
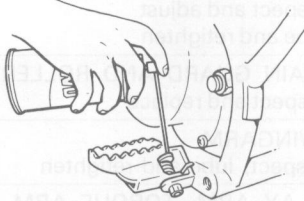
B. Use SAE 30 ~ 50 motor oil for grease-sealed chain.

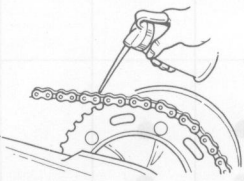
<p>A</p>  <p>All control cables</p>	<p>A</p>  <p>Brake and clutch lever pivots</p>	<p>A</p>  <p>Brake arm pivot</p>
<p>A</p>  <p>Shift lever pivot</p>	<p>A</p>  <p>Kickstarter pivot</p>	<p>A</p>  <p>Footpeg pivot</p>
<p>A</p>  <p>Throttle-to-handle contact area</p>	<p>B</p>  <p>Drive chain</p>	

C. Lubricate the following areas with high-quality, lithium base grease:

CAUTION:

Wipe off any excess grease, and avoid getting grease on the brake shoes.

Throttle guide and wire end	Brake and clutch wire ends	Wheel axle collar
Brake shoe cam and pivot	Wheel axles and pivot shaft	Steering bearing and dust cover
Brake pedal pivot	Meter gear unit	Rear shock pivot (lower)
Relay arm bearing and oil seal Connecting rod bearing and oil seal		Rear shock pivot (upper bushing)

SPECIAL TOOLS

The following special tools are required to perform maintenance, adjustments, and repairs on your machine. These tools can be obtained through your Yamaha dealer.

1 Dial gauge (T/No. YU-03097)

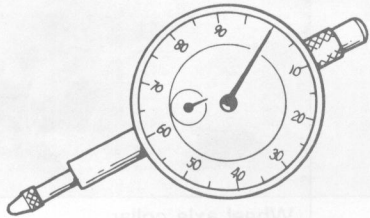

2 Dial gauge stand (T/No. YU-01256-1)

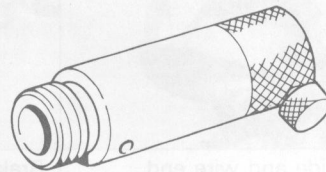

3 Dial gauge extension (T/No. YU-01256-2)

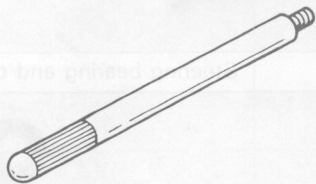

Tools 1, 2, and 3 are used to set the ignition timing.

4 Timing light (T/No. YU-08037)

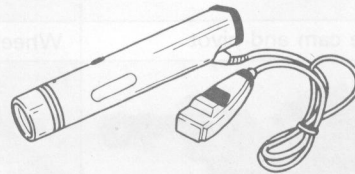

Use this tool to check the ignition timing.

5 Yamaha pocket tester (YU-03112)

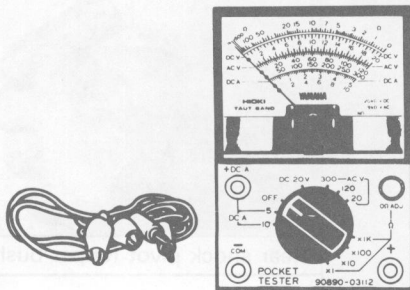

Use this tool to measure the coil resistance, output voltage and amperage.

6 Clutch holding tool (T/No. YM-91042)

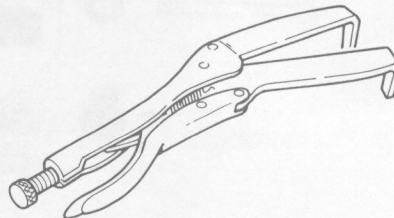

Use this tool to hold the clutch boss while removing or tightening the clutch boss nut.

7 Crankcase separating tool (T/No. YU-01135)

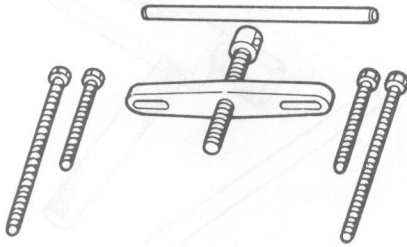

This tool is used to split the crankcases as well as remove the crankshaft from either case.

8 Crankshaft installing tool (T/No. YU-90059)

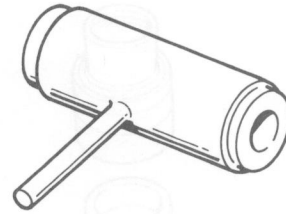

9 Spacer (T/No. YU-90058)

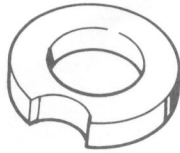

10 Crankshaft installing bolt and adapter (T/No. YU-90060, YU-90063)

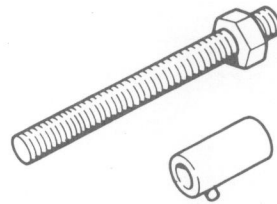

Tools 8, 9, and 10 are used to install the crankshaft.

11 Rotor holding tool (T/No. YU-01235)

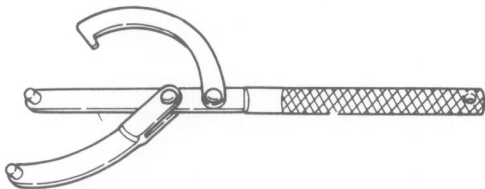

Use this tool to hold the flywheel magneto while removing or tightening the magneto boss nut.

12 Flywheel magneto puller (T/No. YM-01189)

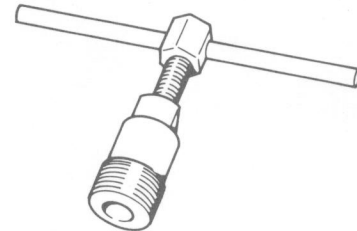

This tool is used to remove the flywheel magneto.

13 Steering nut wrench (T/No. YU-01268)

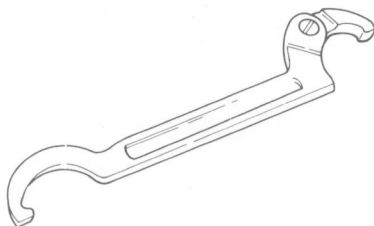

Use this wrench to put the proper tension on the steering head bearings.

14 Fork cylinder holder and adapter (T/No. YM-01327, YM-01326)

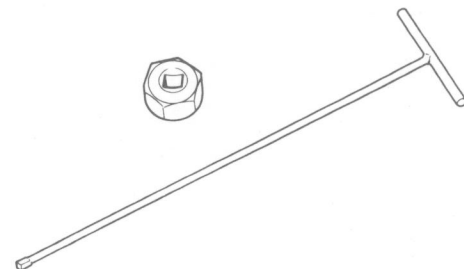

Use these tools to remove and install the fork cylinder.

15 Fork seal and bushing service tool (T/No. YM-08020)

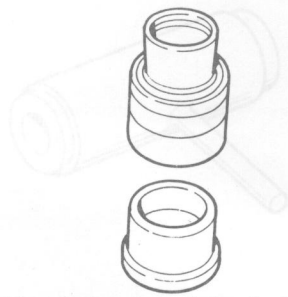

This tool is used to install the fork oil seal.

16 Drive chain cutter (YM-01286)

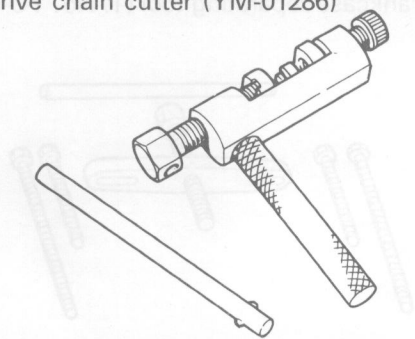

Use this tool to remove or install the drive chain.

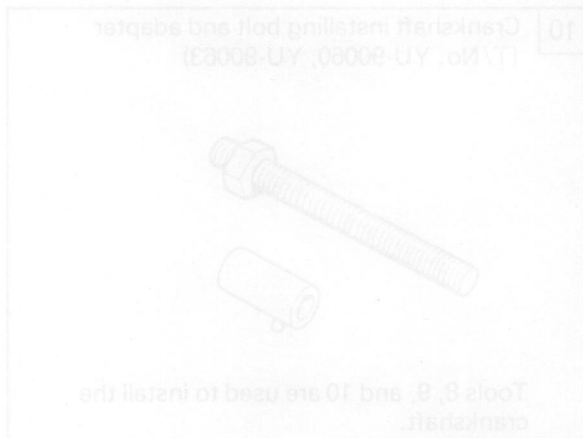

Tools 9, 9, and 10 are used to install the

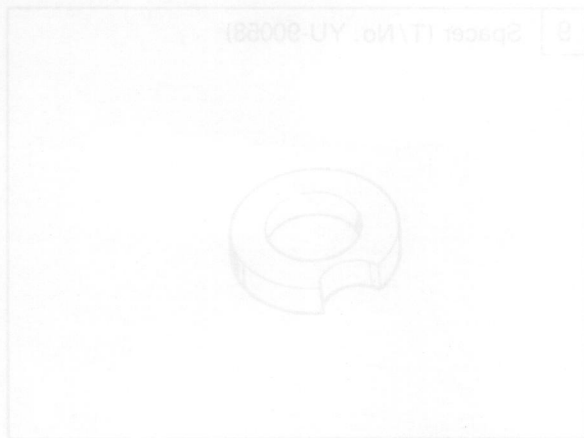

This tool is used to remove the flywheel magneto.

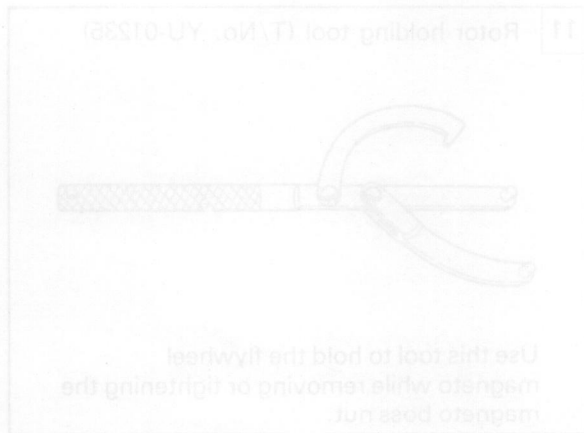

Use this tool to hold the flywheel magneto while removing or tightening the magneto base nut.

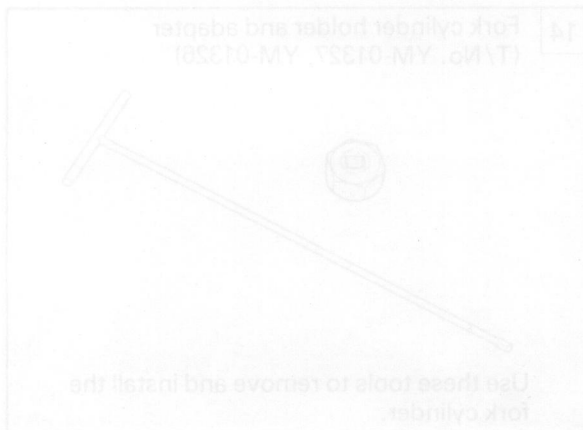

Use these tools to remove and install the fork cylinder.

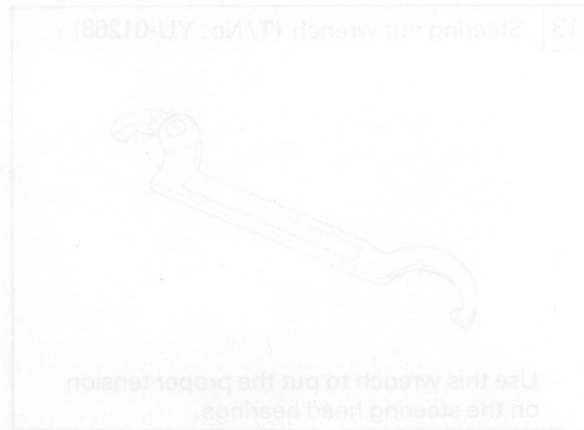

Use this wrench to put the proper tension on the steering head bearings.

MINOR MAINTENANCE AND ADJUSTMENT

Spark plug

Standard spark plug:

IT490K N-3C (CHAMPION)
IT250K N-86 (CHAMPION)

Spark plug gap:

IT490K 0.7~0.8 mm
(0.028~0.031 in)
IT250K 0.5~0.6 mm
(0.020~0.024 in)

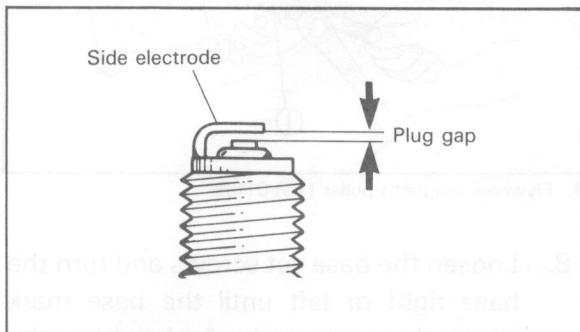

1. Be sure to clean the gasket surface and threads before installing the spark plug. Torque the plug to specification.

Spark plug torque:
25 Nm (2.5 m·kg, 18 ft·lb)

NOTE:

If a torque wrench is not available when you are installing a spark plug, a good estimate of the correct torque is 1/2 to 1/4 turns past finger tight. Have the spark plug torqued to the correct value as soon as possible with a torque wrench.

IGNITION TIMING

Checking

Ignition timing is checked with a timing light by observing the position of the case mark and rotor mark.

1. Remove the crankcase cover (L).
When removing, press the shift pedal down.
2. Connect the timing light to the spark plug lead wire.

3. Start the engine and keep it running at the specified speed. Use a tachometer for checking.

Specified speed: 2,000 r/min

4. While keeping the engine running at a specified speed, check that the rotor mark is aligned with the case mark. If they are not aligned, adjust the ignition timing.

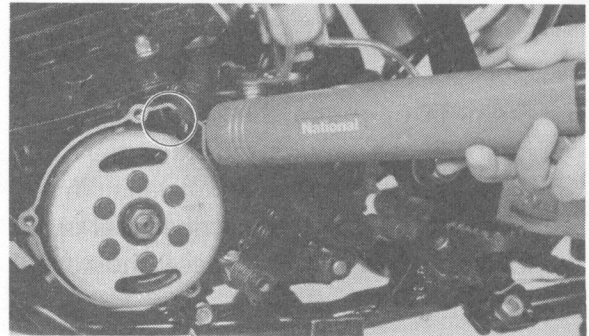

Adjustment

The ignition timing must be set precisely to ensure that the ignition spark occurs at the proper time to provide optimum engine power.

1. Remove the spark plug, side cover (L), expansion chamber, and the left-hand crankcase cover.
2. Screw the dial gauge stand into the spark plug hole.
3. Install the extension on the dial gauge, and slide the dial gauge assembly into the dial gauge stand.

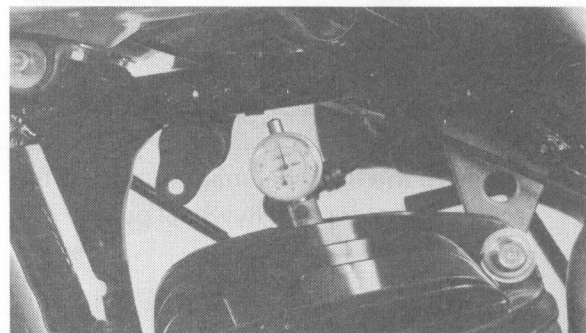

4. Rotate the magneto rotor until the piston reaches top dead center (TDC). When this happens, the needle on the dial gauge will stop and reverse directions even though the rotor is being turned in the same direction. Zero the dial gauge at TDC.

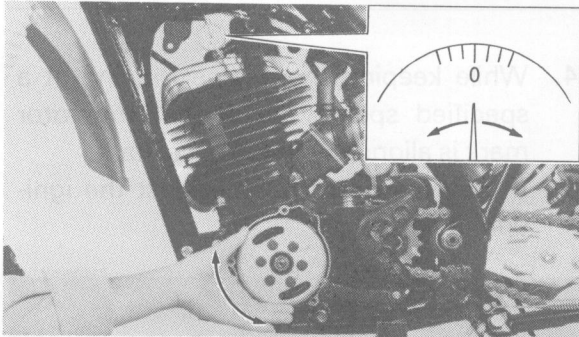

5. From TDC, rotate the rotor clockwise until the dial gauge indicates that the piston is at a specified distance from TDC. At this point, the scribed marks on the rotor and the crankcase should be aligned.

Ignition timing: B.T.D.C.

IT490K.....	2.00 ± 0.1 mm (0.079 ± 0.04 in)
IT250K.....	1.65 ± 0.1 mm (0.065 ± 0.04 in)

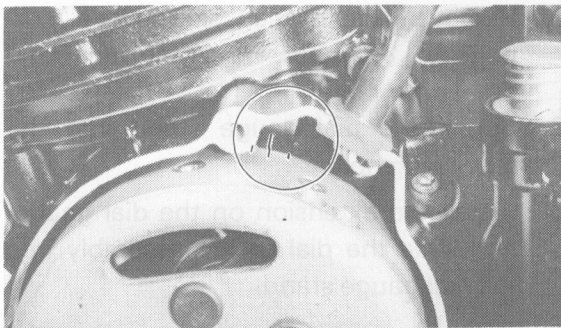

6. If the marks are not aligned, punch a new mark on the crankcase in line with the rotor mark.
7. Remove the flywheel magneto using the magneto holder and flywheel puller.

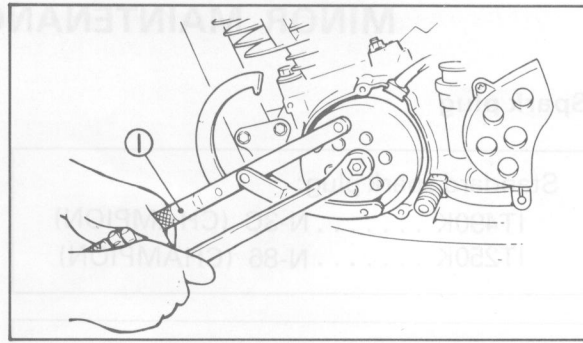

1. Rotor holding tool (YU-01235)

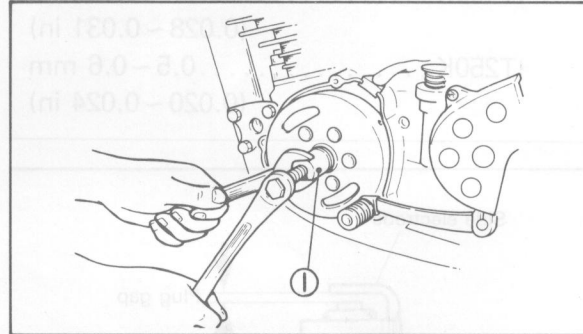

1. Flywheel magneto puller (YM-01189)

8. Loosen the base set screws and turn the base right or left until the base mark aligns the new mark. And tighten the base set screws.

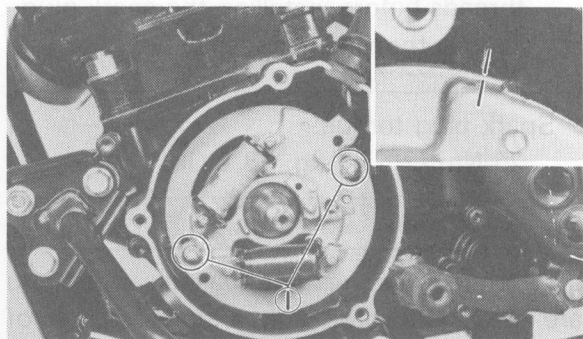

1. Set screw

9. Reinstall the flywheel and tighten the nut.

Tightening torque:
80 Nm (8 m · kg, 56 ft · lb)

10. Remove the dial gauge assembly and stand, and reinstall the spark plug. Torque the plug to specification.

Spark plug torque:
25 Nm (2.5 m · kg, 18 ft · lb)

11. Reinstall the left-hand crankcase cover, expansion chamber, and the side cover.

Throttle cable

1. Check the free play in the throttle twist grip; the play should be 3 ~ 5 mm (0.12 ~ 0.20 in) at the edge of the inner flange of the grip.

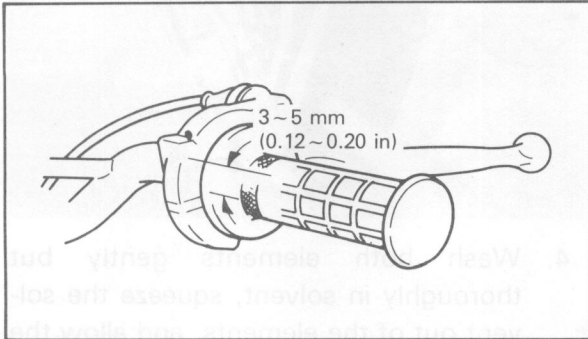

2. To adjust the free play, loosen the lock nut on the cable adjuster and turn the adjuster in or out to achieve the proper free play. Retighten the lock nut.

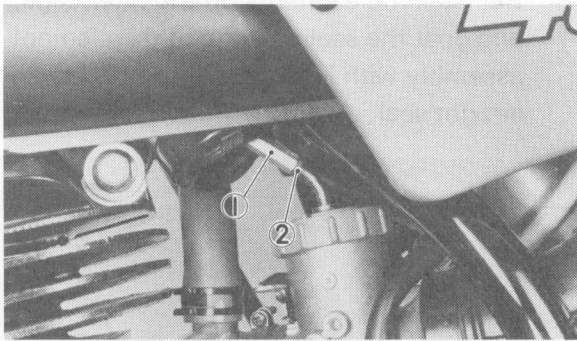

1. Adjuster 2. Lock nut

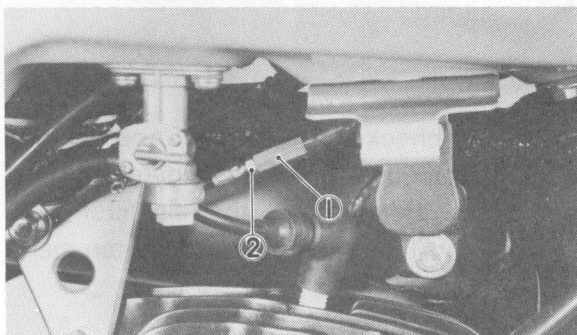

1. Adjuster 2. Lock nut

3. After adjustment, start the engine and check throttle operation. Turn the handlebars from lock to lock and note if the engine speeds up; if it does, the cable adjustment is too tight and must be readjusted.

Idle speed

1. Screw in the pilot air screw until it is lightly seated.
2. Back out by the specified number of turns. Start the engine and let it warm up.

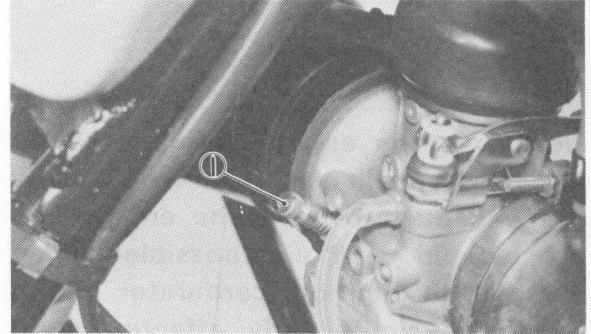

1. Pilot air screw

Pilot air screw setting:

IT490K	1 and 3/8
IT250K	1 and 1/4

3. Loosen the lock nut on the throttle stop screw and turn the screw until the idle is at the desired rpm.

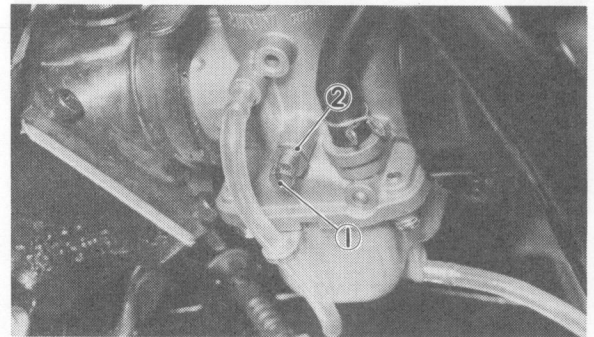

1. Throttle stop screw 2. Lock nut

4. Turn the pilot air screw in or out in 1/8-turn increments to achieve the highest rpm with just the pilot screw.
5. Once again, turn the throttle stop screw to attain the desired idle rpm, and tighten the lock nut.

The throttle response off idle should be crisp and clean, without any hesitation. If the engine is completely warmed up and hesitates off idle, turn the pilot air screw in or out in 1/8-turn increments until the problem is eliminated.

Air filter

Proper air filter maintenance is the biggest key to preventing premature engine wear and damage. All elements of the air filter system should be maintained after every moto; engine life will be prolonged and power output will remain consistent.

CAUTION:

Never run the engine without the air filter elements in place; this would allow dirt and dust to enter the engine and cause rapid wear and possible engine damage. In addition, carburetor jetting would be significantly affected, with subsequent poor performance and possible overheating.

1. Remove the side cover (R), and pull out the rubber band and filter case cover.

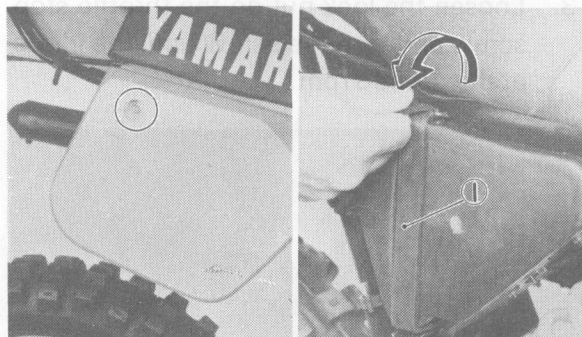

1. Rubber band

2. Remove the two wing nuts and remove the air filter element assembly from the box.

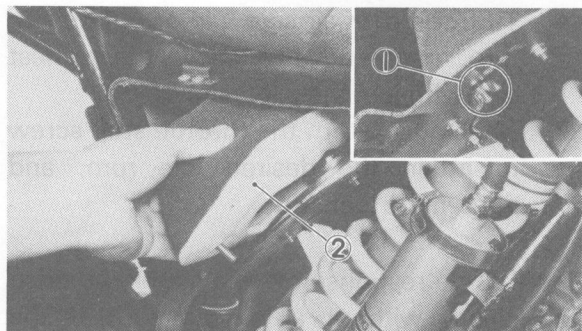

1. Wing nut 2. Double-layer elements

3. Separate the two elements from the filter cage.

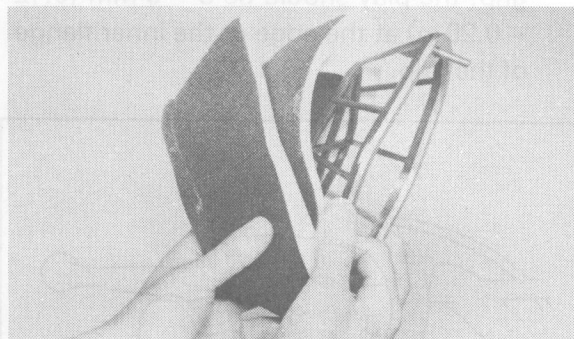

4. Wash both elements gently but thoroughly in solvent, squeeze the solvent out of the elements, and allow the elements to dry.
5. Pour a small quantity of **foam-air-filter oil** on the elements and work it thoroughly into the foam. Squeeze out the excess oil.
6. Reinstall the elements on the filter cage, and coat the sealing edge of the element assembly with light grease to provide an airtight seal.

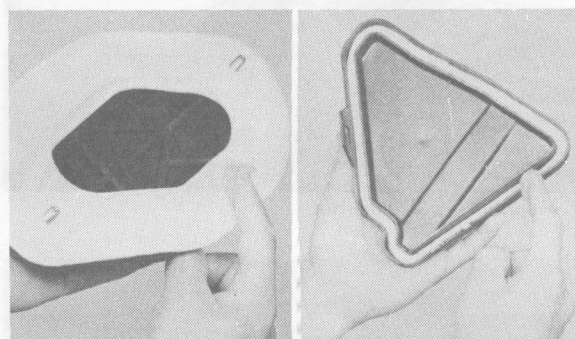

7. After checking the air inlet hose for any obstructions, carefully reinstall the element assembly in the air filter box. Reinstall the wing nuts and tighten them.

CAUTION:

Do not overtighten the wing nuts to avoid distorting the filter element cage.

8. Reinstall the side cover.
9. Inspect the air filter joint and intake manifold rubber for tears and cracks. Replace them if any damage is found.

Clutch

To avoid clutch slipping or dragging, the clutch mechanism and cable must be adjusted correctly.

1. Adjust the cable adjuster at the handle lever to provide 2 ~ 3 mm (0.08 ~ 0.12 in) of free play at the clutch lever pivot; tighten the lock nut.

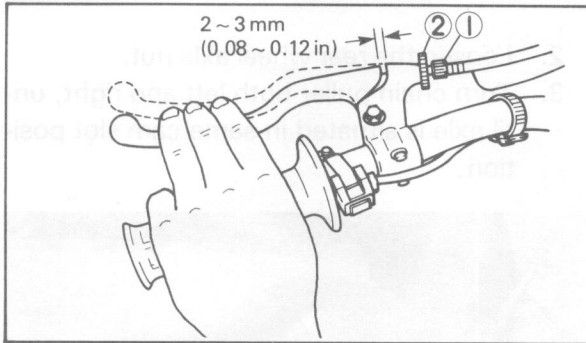

1. Adjuster 2. Lock nut

* For clutch mechanism adjustment refer to page 3-13 of clutch.

Front brake

The front brake can be adjusted to suit rider preference within a 5 ~ 8 mm (0.2 ~ 0.32 in) free play at the brake lever pivot.

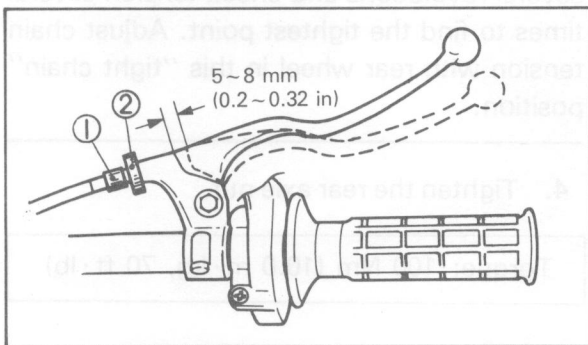

1. Adjuster 2. Lock nut

1. Make sure the cable adjuster at the handle lever is screwed all the way in.
2. Loosen the lock nut on the cable adjuster at the brake backing plate, and turn the adjuster in or out to achieve 8 mm of free play at the brake lever pivot. Tighten the lock nut.

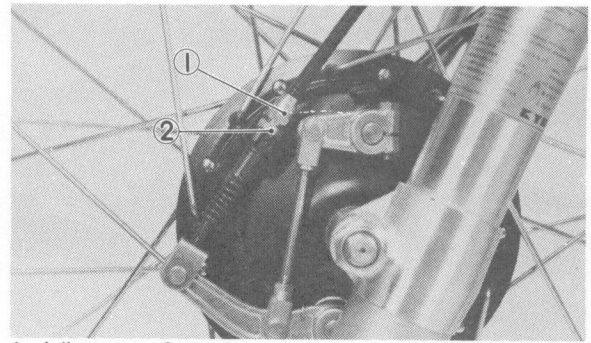

1. Adjuster 2. Lock nut

3. At the handle lever, turn the adjuster out to achieve the desired free play within the specified range. Tighten the lock nut.

For two leading shoe brake adjustment, refer to "4-3" of WHEELS.

Rear brake

In adjusting the rear brake, the pedal height should first be set and then the free play should be adjusted.

1. Loosen the lock nut on the brake pedal height adjuster, and turn the adjuster to achieve the desired pedal height according to rider preference. Tighten the lock nut.

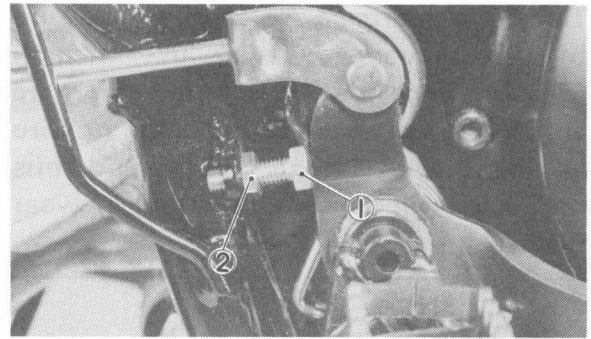

1. Adjuster 2. Lock nut

2. Turn the adjusting nut on the end of the brake rod in or out to achieve the desired free play within 20 ~ 30 mm (0.8 ~ 1.2 in).

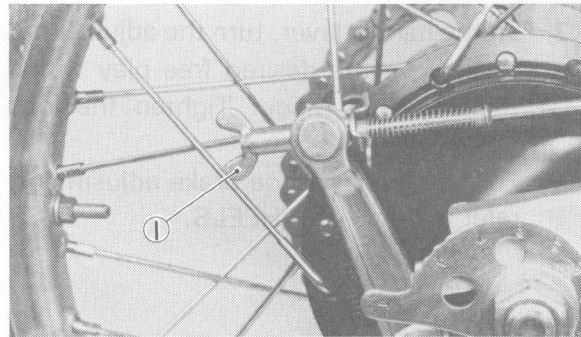
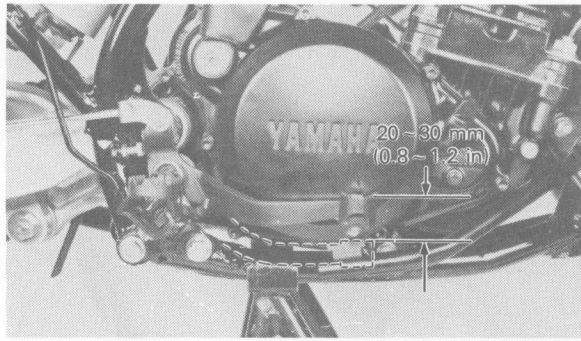

1. Adjusting nut

DRIVE CHAIN

This machine has a drive chain with O-rings between the chain plates.

CAUTION:

To clean the grease-sealed chain, be sure to use kerosene. Never use a high pressure washes, steam cleaning, a volatile solvent such as gasoline, or wire brush. It will damage O-rings and thus the chain will also be damaged or wear faster.

Lubrication

After washing, dry up the chain and lube it with "SAE 30 ~ 50 motor oil". Avoid using any other lubricants because it contains a solvent.

Free play adjustment

1. With the machine standing vertically and rider on it, check the free play at the position shown below; the normal vertical free play is 20 ~ 30 mm (0.79 ~ 1.18 in). If the free play exceeds 30 mm (1.18 in), the chain must be adjusted.

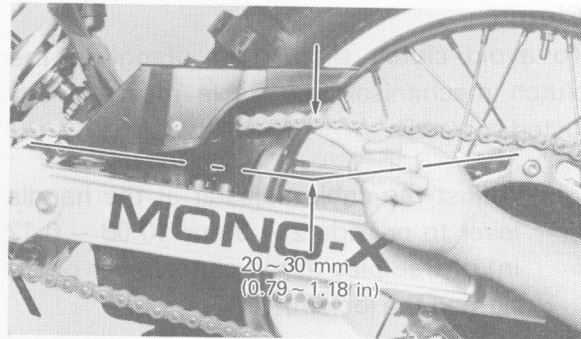

2. Loosen the rear wheel axle nut.
3. Turn chain puller both left and right, until axle is situated in same cam slot position.

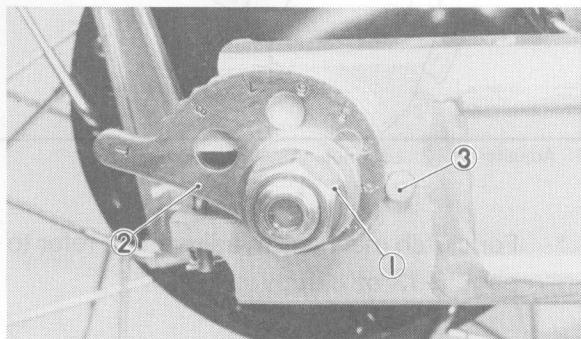

1. Axle nut 2. Chain puller 3. Cam stopper

NOTE:

Before adjusting, rotate rear wheel through several revolutions and check tension several times to find the tightest point. Adjust chain tension with rear wheel in this "tight chain" position.

4. Tighten the rear axle nut.

Torque: 100 Nm (10.0 m·kg, 70 ft·lb)

5. Check the brake pedal free play.

WARNING:

The brake pedal free play and the rear axle alignment must always be checked after the chain is adjusted or the rear wheel is removed.

Wear limit

The wear limit of the drive chain is determined by chain stretch. Measure chain stretch for 10-pitch distance with a vernier caliper as follows.

If the stretch exceeds the wear limit, replace the chain with a new one.

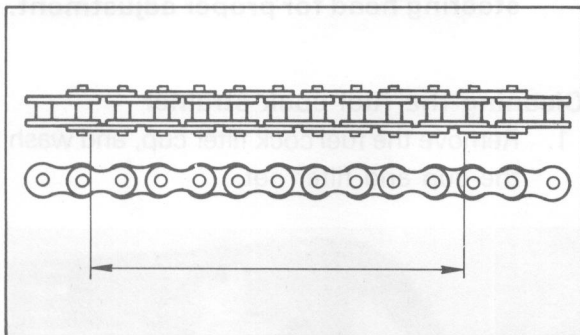

Wear limit: 150.1 mm (5.91 in)

1. To remove or install the chain, the drive chain cutter is required.

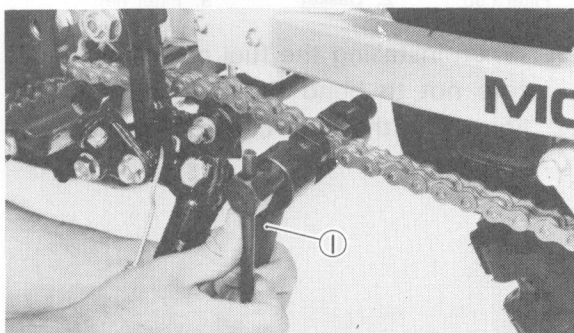

1. Drive chain cutter (YM-01286)

2. When installing, take care of the following instructions:
 - a. Always use a new joint. Don't forget to install O-rings.

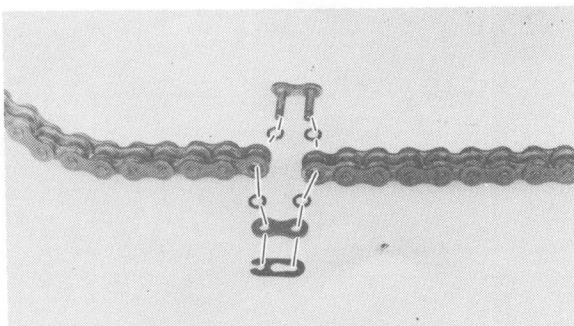

- b. Check that all link O-rings are installed. If any one of them is missing, replace the chain with a new one.
- c. During reassembly, the master link clip must be installed with the rounded end facing the direction of travel.

NOTE:

The chain should be cleaned and lubricated after every use of the machine.

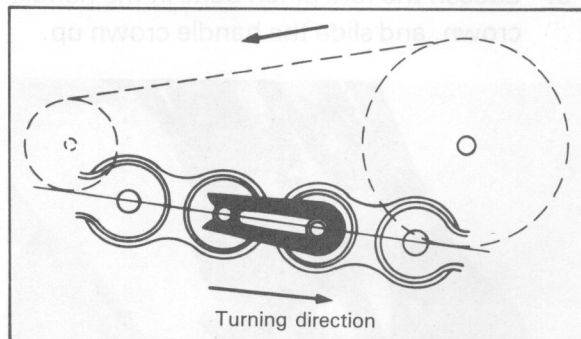

Steering head

1. Block the front wheel off the ground, grab the bottom of the fork legs, and gently push and pull the legs to check for free play in the steering head. If there is any noticeable play in the steering head, the bearings must be adjusted. In addition, check to see that the forks swing from lock to lock without any binding or catching. If any such binding is noticed, the bearings should be cleaned, inspected, and readjusted after thorough greasing.

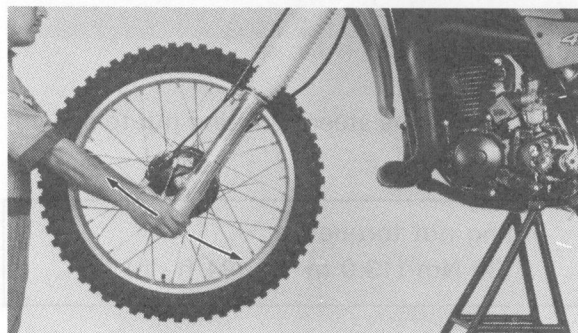

2. To adjust the bearings, first loosen the steering fitting nut.

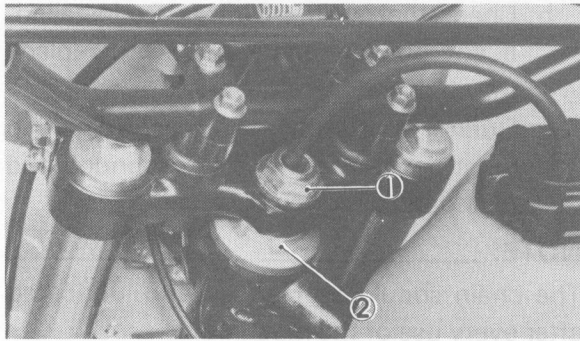

1. Steering fitting nut 2. Ring nut

3. Loosen the fork pinch bolts in the handle crown, and slide the handle crown up.

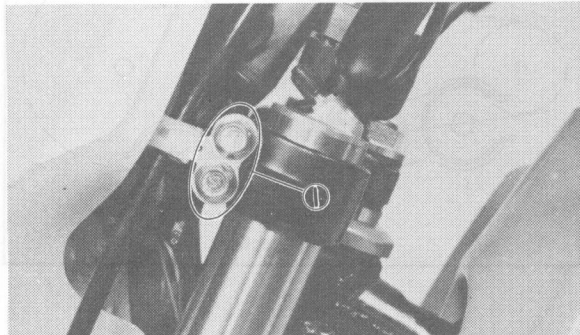

1. Fork pinch bolt

4. Tighten the ring nut beneath the handle crown with the steering nut wrench until the free play is eliminated and there is no binding.

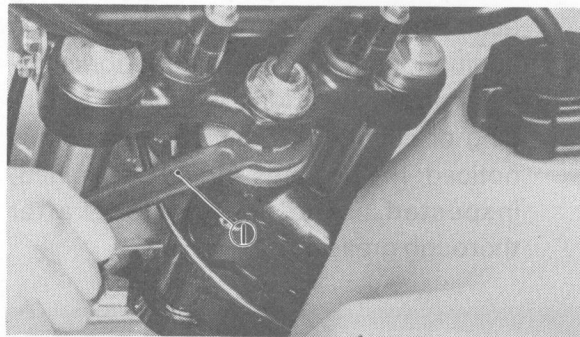

1. Steering nut wrench (YU-01268)

5. Torque the steering fitting nut to specification.

Fitting nut torque:
130 Nm (13.0 m · kg, 94 ft · lb)

6. Tighten the fork pinch bolts to specification.

Pinch bolt torque:
23 Nm (2.3 m · kg, 17 ft · lb)

- * After a short running period, check steering head for proper adjustment.

Cleaning the fuel cock strainer

1. Remove the fuel cock filter cup, and wash the cup and filter net.

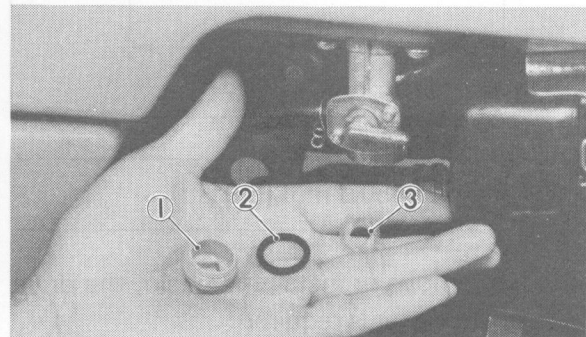

1. Filter cup 2. Gasket 3. Filter net

2. When installing the fuel cock filter, use care not to bend the filter net. Avoid tightening the filter cup excessively.

3 ENGINE MAINTENANCE AND REPAIR

PREPARATION FOR SERVICE	3-1
DISASSEMBLY, INSPECTION AND ASSEMBLY	3-2
CARBURETOR	3-2
Main jet replacement	3-2
Inspection	3-3
YAMAHA ENERGY INDUCTION SYSTEM (Y.E.I.S.)	3-4
Inspection	3-4
REED VALVE	3-5
Inspection	3-5
MUFFLER	3-5
Removal	3-5
Maintenance	3-5
CYLINDER HEAD	3-6
Removal	3-6
Maintenance	3-6
CYLINDER	3-7
Removal	3-7
Maintenance	3-7
PISTON ASSEMBLY	3-8
Removal	3-8
Maintenance	3-8
Piston outside diameter measurement	3-9
Piston rings	3-9
Piston pin, bearing	3-10
CLUTCH	3-11
Removal	3-11
Maintenance	3-12
Installation	3-13
Primary drive and driven gears	3-14
KICK STARTER	3-14
Removal	3-14
Inspection	3-15
Reassembly	3-15

SHIFTER	3-15
Removal	3-16
Inspection	3-16
Installation	3-16
CRANKCASE	3-16
Engine removal	3-16
Mounting	3-17
Crankcase disassembly	3-17
Transmission	3-18
Inspection	3-18
Transmission installation	3-20
Bearings and oil seals	3-21
Crankshaft	3-21
Inspection	3-21
Crankshaft installation	3-22

3 ENGINE MAINTENANCE AND REPAIR

PREPARATION FOR SERVICE

Prior to beginning any work on the engine, take note of the following bits of advice; they will greatly facilitate your engine maintenance and repair:

- Clean your machine as described in the General Information section entitled, "Cleaning and Storage";
- Group the parts of each component on individual trays, and arrange the parts in the order of their removal;
- When replacing parts, always use the genuine Yamaha article to maintain optimum performance, durability, and safety;
- All gaskets and seals should be replaced during engine work, and all gasket surfaces should be clean;
- During assembly, always apply oil or grease to bearing surfaces to protect them upon initial start-up;
- Replace all circlips which are distorted from use or disassembly;
- Always replace cotter pins and piston pin clips after one use;
- Always clean and oil the threads of nuts, bolts, and screws during assembly, and torque them to the proper specifications whenever possible.

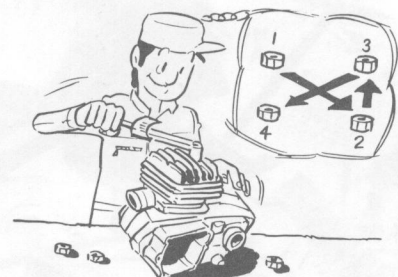
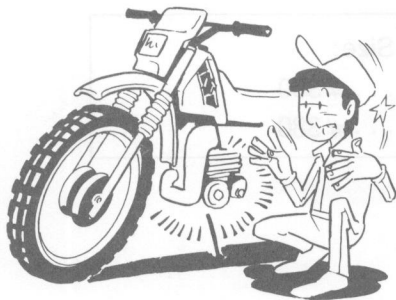
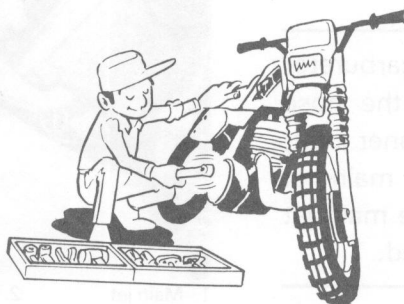
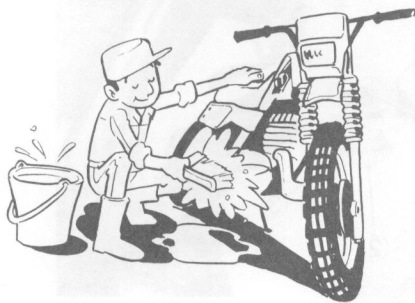

DISASSEMBLY, INSPECTION AND ASSEMBLY

CARBURETOR

For details of carburetor tuning, refer to the Race preparation and Tuning Manual.

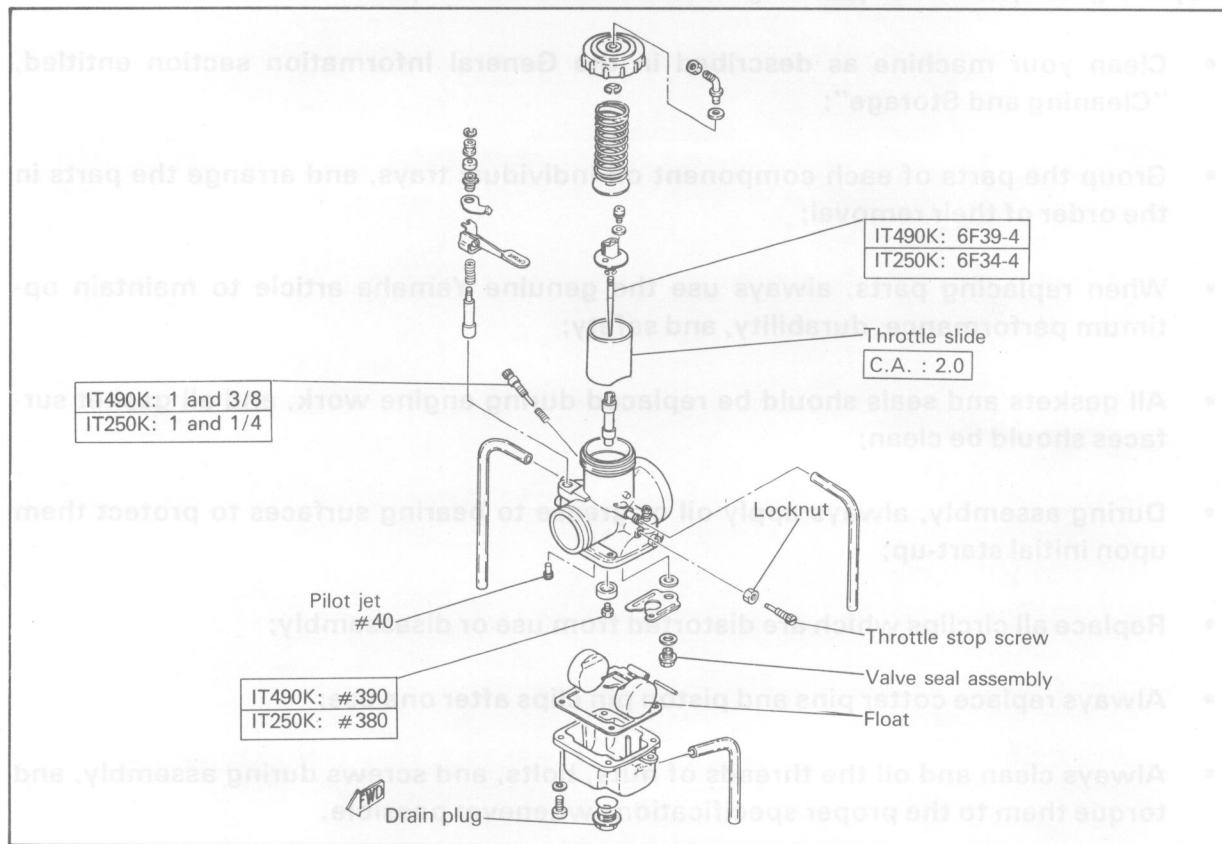

Main jet replacement

NOTE: _____

It is not necessary to remove the carburetor to replace the main jet: Loosen the hose clamps on the manifold and air cleaner joint, rotate the carb, and remove the main jet cover bolt from the float bowl. The main jet can thereby be removed and replaced.

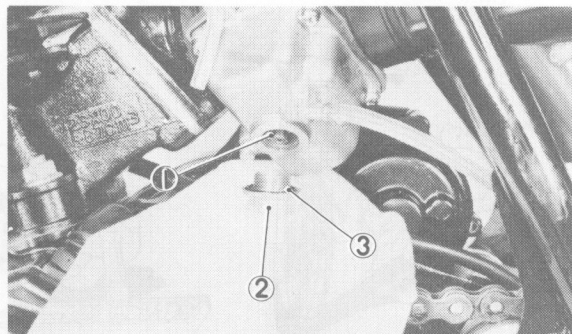

1. Main jet 2. Cover bolt 3. O-ring

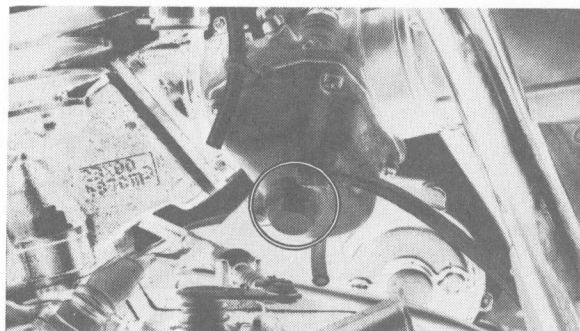

Standard Main Jet Size:	
IT490K	# 390
IT250K	# 380

WARNING:

When the main jet cover bolt is removed, the fuel in the float bowl will drain. Do not remove the bolt when the engine is hot. Place a rag under the carb when removing the bolt to catch the fuel. Remove the bolt in a well-ventilated area, away from any open flame. Always clean and dry the machine after completing main jet changes.

IMPORTANT:

The carburetor has been set for operation at or near sea level; in most instances, it will not require changes. Some conditions, however, do demand carb setting changes to maintain performance. If this is the case, make the changes in small increments and check the results with a spark plug check. Improper settings can lead to poor performance or possible engine damage. If you are in doubt as to what setting changes to make, consult your Yamaha dealer.

Inspection

1. Examine carburetor body and fuel passages. If contaminated, wash carburetor in petroleum-based solvent. Do not use caustic carburetor cleaning solutions. Blow out all passages and jet with compressed air.
2. Examine condition of floats. If floats are damaged, they should be replaced.
3. Inspect inlet float valve and seat for wear or contamination. Replace these components as a set.

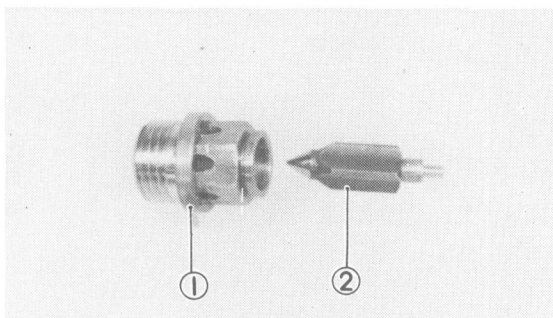

1. Valve seat 2. Float valve

4. Hold the carburetor in an upside down position.

Incline the carburetor at 60° ~ 70° (so that the end of the float valve does not hang down of float weight), and measure the distance from the mating surface of the float chamber (gasket removed) to the top of the float using a gauge.

Folat height:

IT490K.....	27 ± 1 mm
	(1.1 ± 0.04 in)
IT250K.....	24.0 ± 1 mm
	(0.94 ± 0.04 in)

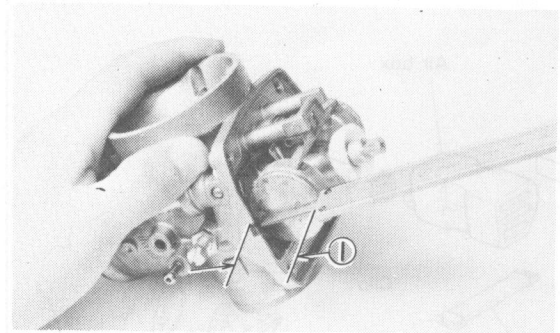

1. Float height

CAUTION:

Check the float valve and valve seat for wear before adjustment.

Make the adjustment by bending the tang on the float arm.

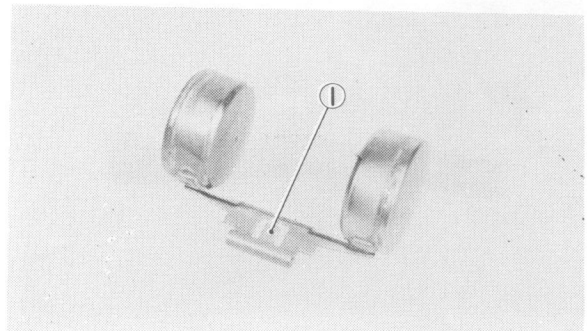

1. Tang

YAMAHA ENERGY INDUCTION SYSTEM (Y.E.I.S.)

CAUTION:

Never attempt to modify the Yamaha Energy Induction System.

The air chamber and hose should be handled with special care.

Any imperfect connection or installation of these parts or damaged parts will have an adverse effect on the performance of the system. Check parts, and be sure to replace any defective one.

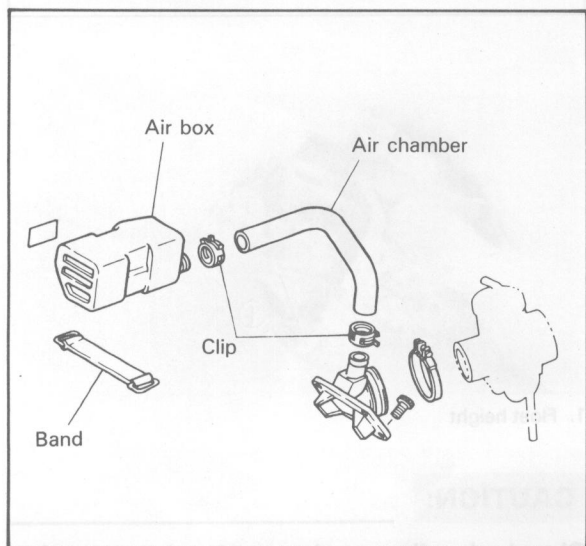

Inspection

1. Check the hose and air chamber for cracks or any other damage. If there is any cracks or damage, replace them.

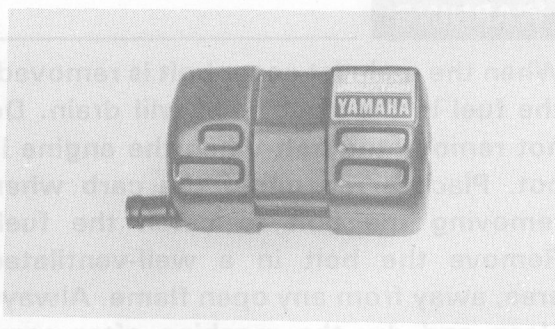
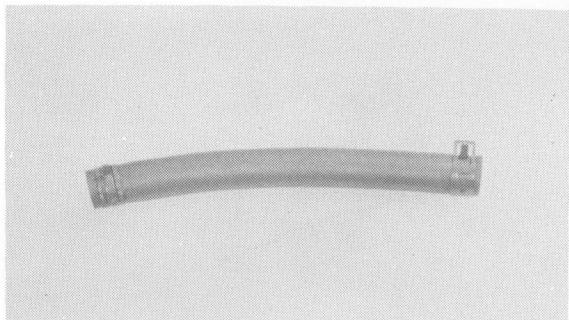

2. Check the tightness of hose clip, and retighten as required.

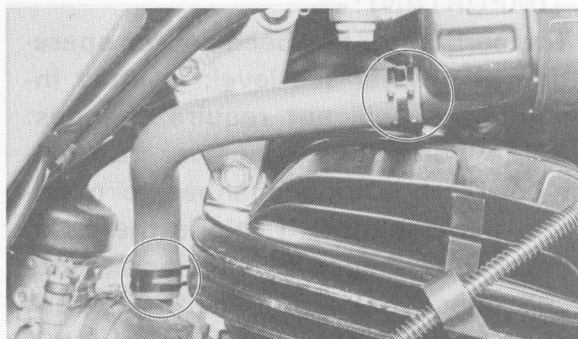

NOTE:

The fuel tank is provided with the Y.E.I.S. air chamber. When removing or mounting the fuel tank, first remove the band holding the air chamber.

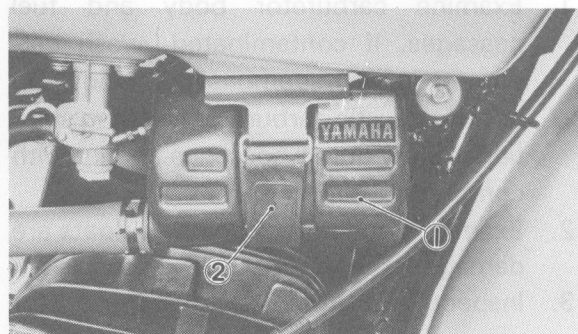

1. Air box
2. Rubber band

REED VALVE

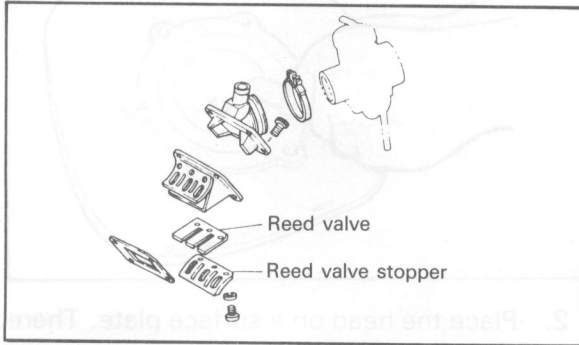

Inspection

1. Inspect rubber intake manifold for signs of weathering, checking or other deterioration.
2. Inspect reed petals for signs of fatigue and cracks. Reed petals should fit flush or nearly flush against neoprene seats. If in doubt as to sealing ability, apply suction to carburetor side of assembly. Leakage should be slight to moderate.
3. Check reed valve for bending. If beyond tolerance, replace reed valve.

Reed valve bending limit:
0.6 mm (0.024 in)

4. During reassembly, note the cut in the lower corner of the reed and stopper plate. Use as aid to direction of reed installation.

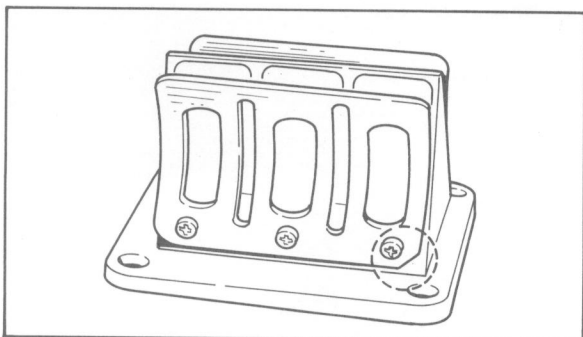

MUFFLER

Removal

1. Remove side cover.
2. Remove muffler and silencer mounting bolts and loosen the muffler joint screws.
3. Remove coil springs at muffler to cylinder joint and remove muffler.

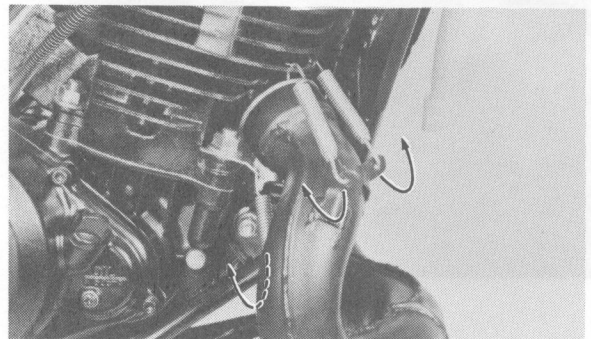
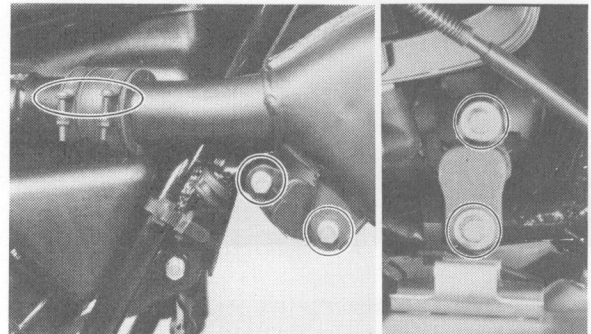
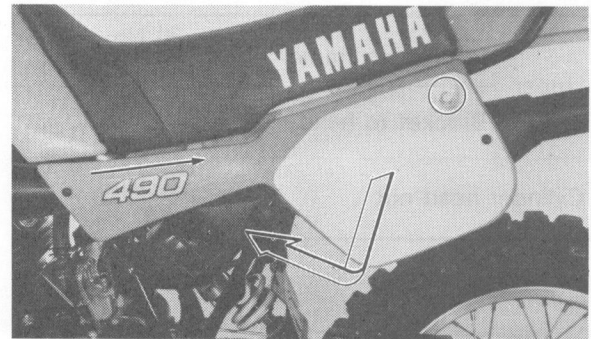

Maintenance

1. Using a rounded scraper, remove excess carbon deposits from manifold area of exhaust pipe.
2. Carbon deposits within the silencer may be removed by lightly tapping the outer shell with a hammer and then blowing out with compressed air. Heavy wire, such as a coat hanger, may be inserted to break loose deposits. Use care.
3. Check the exhaust pipe for cracks. If it has excessive cracks, replace it.

CYLINDER HEAD

Removal

1. Remove the muffler.
2. Remove spark plug lead wire. Loosen, but do not remove spark plug.
3. Remove the cylinder head holding bracket. And remove cylinder head nuts
Remove cylinder head and gasket.

Upper	Bracket to frame	30 Nm (3.0 m·kg, 22 ft·lb)
	Bracket to head	60 Nm (6.0 m·kg, 43 ft·lb)
Cylinder head nut		25 Nm (2.5 m·kg, 18 ft·lb)

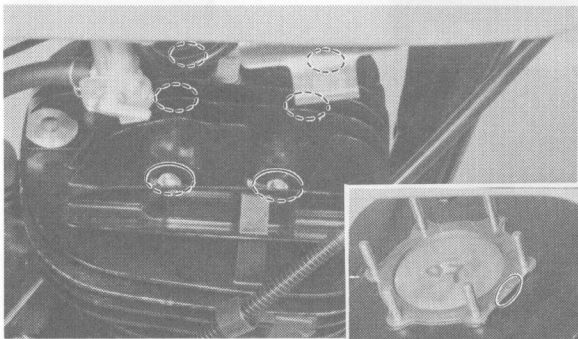
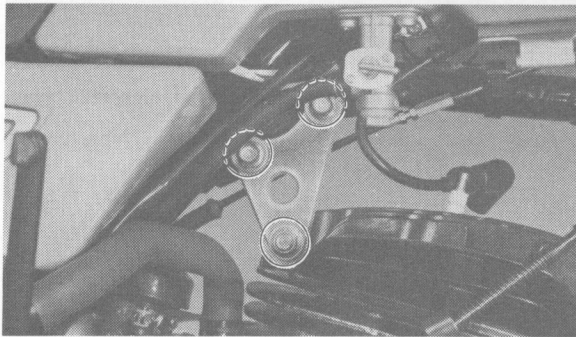

Maintenance

1. Using a rounded scraper, remove carbon deposits from combustion chamber. Take care to avoid damaging the spark plug threads. Do not use a sharp instrument. Avoid scratching the metal surface.

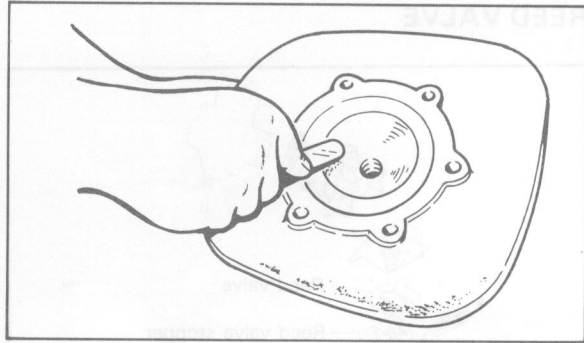

2. Place the head on a surface plate. There should be no warpage. Correct by resurfacing. Place 400 ~ 600 grit wet emery sandpaper on surface plate and resurface head using a figure-eight sanding pattern. Rotate head several times to avoid removing too much material from one side.

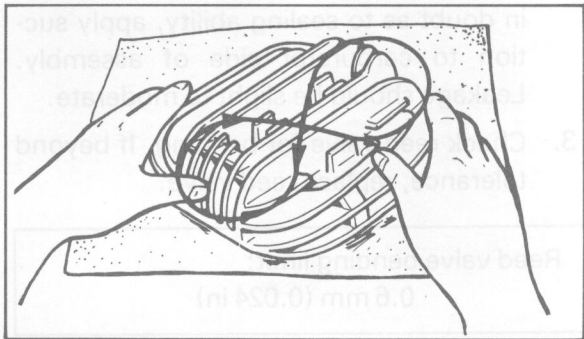

4. During reassembly, note the cut in the lower corner of the reed and stopper plate. Use as aid to direction of reed installation.

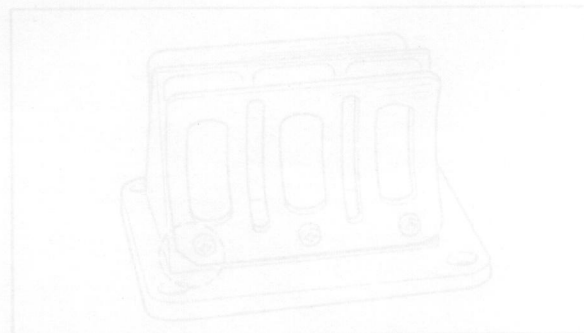

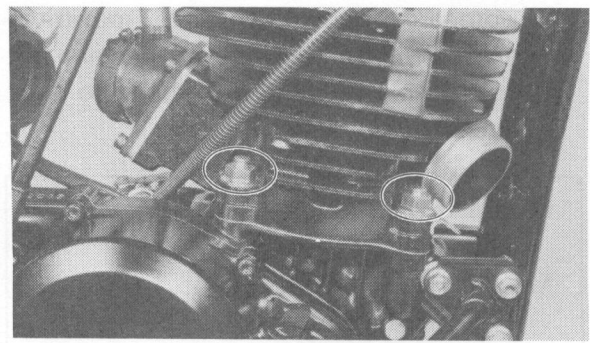
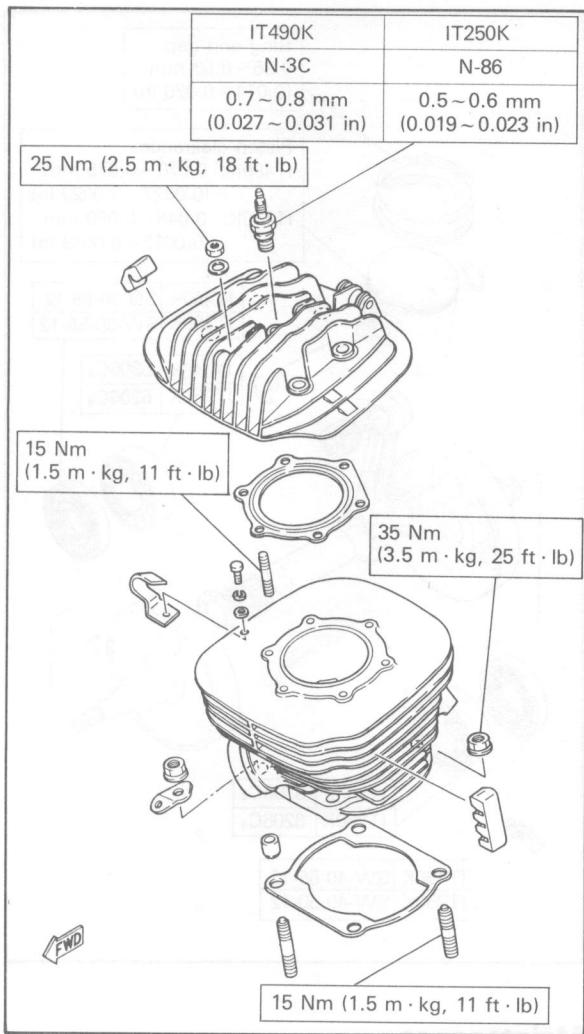

Maintenance

1. Using a rounded scraper, remove carbon deposits from the exhaust port.

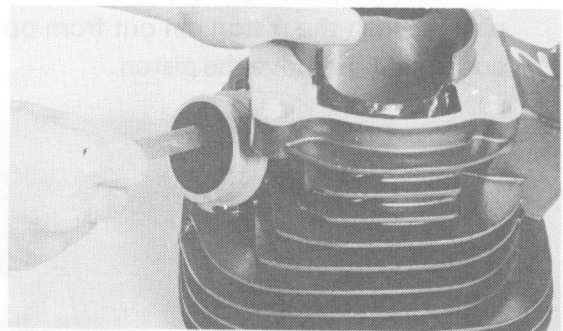

2. Check cylinder bore. Using a cylinder hone, remove any scoring. Hone lightly, using smooth stones. Hone no more than required to avoid excess piston clearance.
3. Using a cylinder gauge set to standard bore size, measure the cylinder. Measure front-to-rear and side-to-side at top, center and bottom just above exhaust port.

CYLINDER

Removal

1. Remove the Y.E.I.S. air chamber and hose.
2. Remove the carburetor.
3. Remove cylinder holding nuts (4).

With the piston at top dead center, rise the cylinder until the cylinder skirts clear crankcase. Stuff a clean shop rag into crankcase cavity, around rod, to prevent dirt and other foreign particles from entering. Remove cylinder and base gasket.

Cylinder holding nut:
60 Nm (6.0 m · kg, 43 ft · lb)

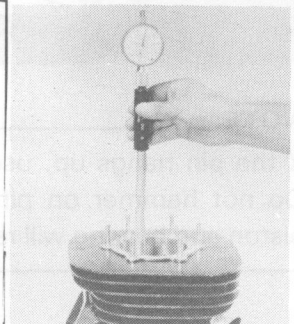
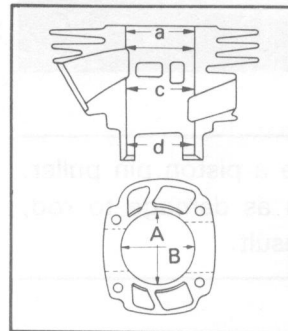

Compare minimum and maximum measurements. If over tolerance and not correctable by honing, rebore to next oversize.

Max. allowable taper:
0.08 mm (0.0031 in)
Max. allowable out-of-round:
0.05 mm (0.0020 in)

PISTON ASSEMBLY

Removal

1. Remove the piston pin clip (1) from the piston. Push the piston pin out from opposite side. Remove the piston.

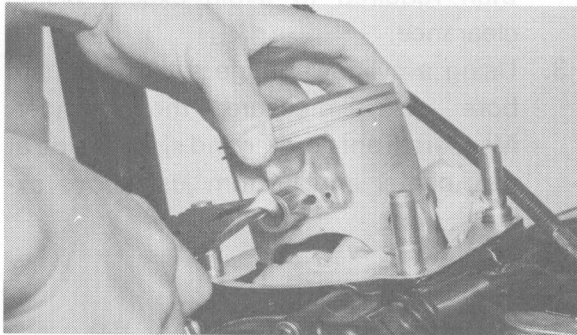
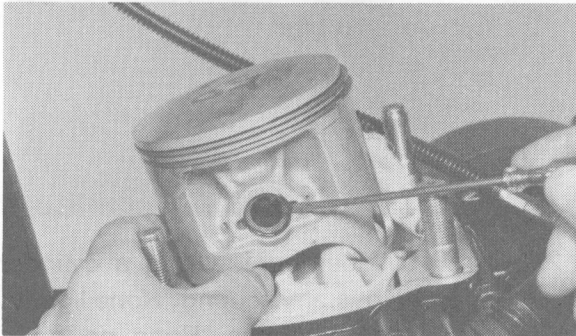

NOTE:

If the pin hangs up, use a piston pin puller. Do not hammer on pin as damage to rod, piston and bearing will result.

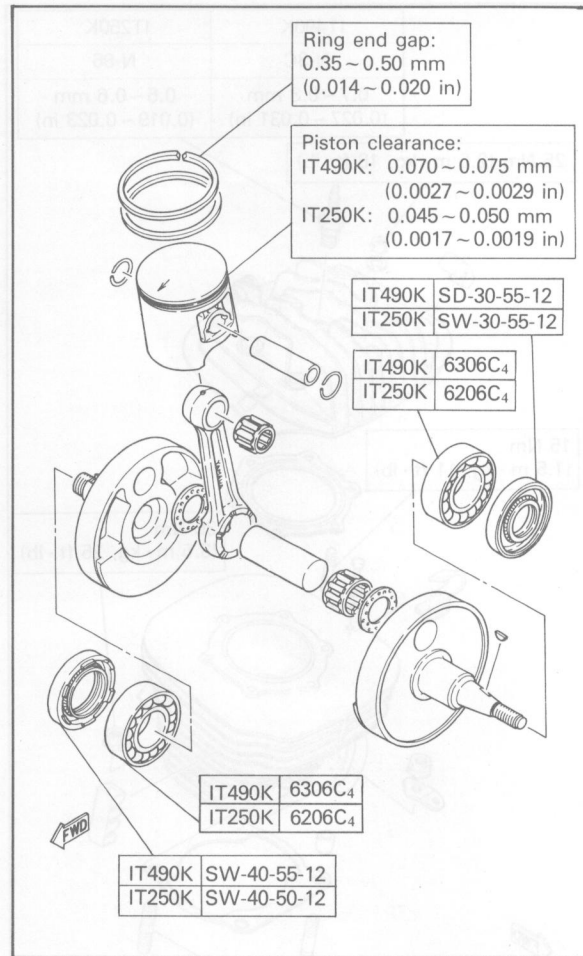

Maintenance

1. Using a rounded scraper, remove carbon deposits from piston crown and ring grooves.

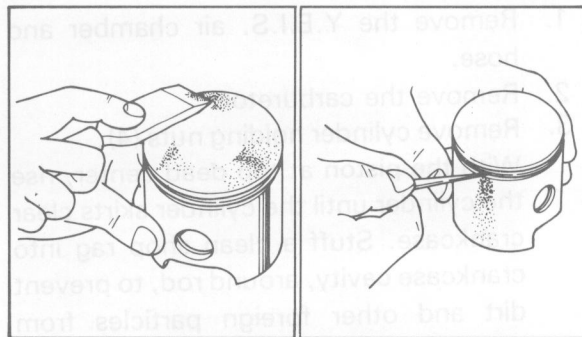

2. Using 400 ~ 600 grit wet sandpaper, lightly sand score marks and lacquer deposits from sides of piston. Sand in crisscross pattern. Do not sand excessively.

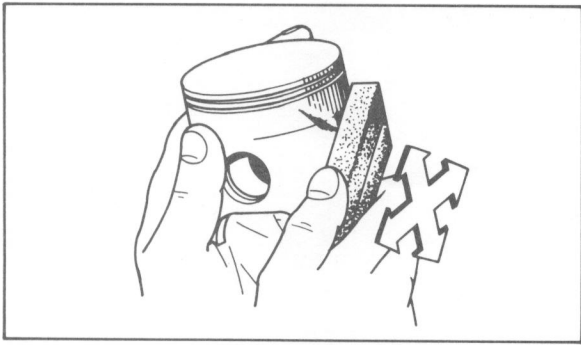

Piston outside diameter measurement

1. To measure a cutaway piston, measure across the skirts at height "H" (just above the intake skirt cutaway) as shown in illustrations 1 and 2. Record this partial measurement.

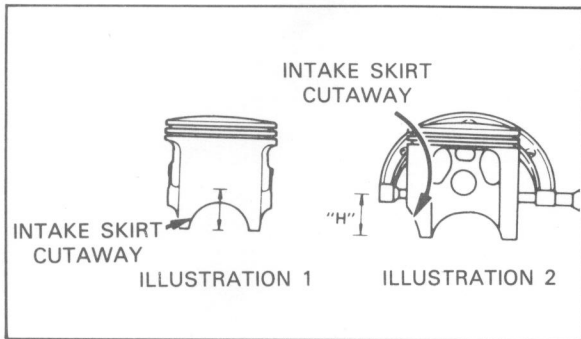

2. Add to this Partial Measurement (PM) the Adjustment Amount (AA) in the following table (PP + AA = piston diameter). The result will be the piston diameter. Use this figure to compute piston-to-cylinder clearance.

HEIGHT "H"	ADJUSTMENT AMOUNT (AA)
10 mm (0.3937 in)	0 mm (0 in)

Remember: Partial measurement + adjustment amount = piston diameter.

Example: 86.950 mm (3.42 in) + 0 mm (0 in) = 86.950 mm (3.42 in) diameter.

Do not try to measure from one of the intake "fingers" to the exhaust skirt. The piston will appear to be undersize. This is due to piston cam grind.

3. To determine the piston-to-cylinder clearance, subtract the piston diameter from the minimum cylinder diameter. If the nominal piston clearance is not within tolerance, replace the piston or bore the cylinder as required.

$\text{PISTON CLEARANCE} =$ $\text{Minimum Cylinder Diameter} -$ $\text{Maximum Piston diameter}$

$87.035 \text{ mm (3.427 in)} - 86.965 \text{ mm (3.423 in)} = 0.070 \text{ mm (0.003 in)}$

Normal piston clearance:

IT490K	0.070 ~ 0.075 mm (0.0028 ~ 0.030 in)
IT250K	0.045 ~ 0.050 mm (0.0018 ~ 0.0020 in)

Piston rings

1. Insert ring into cylinder. Push down approximately 20 mm (0.787 in) using piston crown to maintain right-angle to bore. Measure installed end gap. If beyond tolerance, replace.

Ring end gap installed
0.35 ~ 0.50 mm (0.014 ~ 0.02 in)

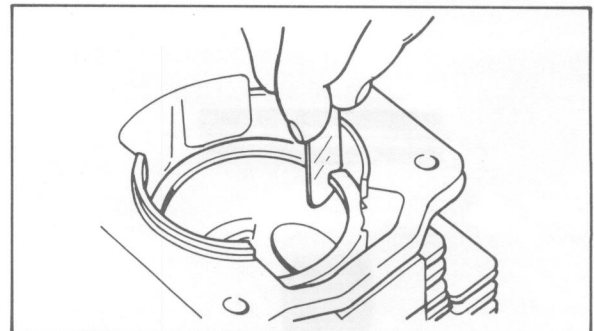

2. Holding cylinder towards light, check for full seating of ring around bore. If not fully seated, check cylinder. If cylinder is not out-of-round, replace piston ring.
3. During installation, make sure ring ends are properly fitted around ring locating pin in piston groove. Apply liberal coating of two-stroke oil to ring.

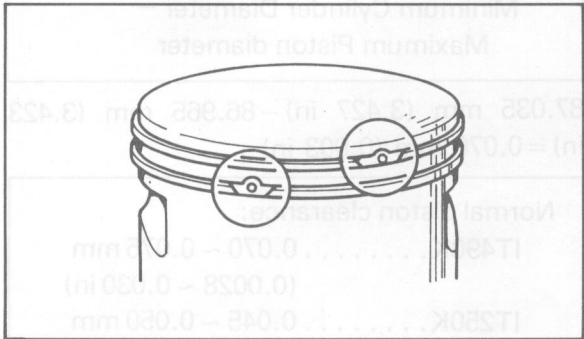

NOTE:

New ring requires break-in. Follow first portion of new machine break-in procedure.

Piston pin, bearing

1. Check the pin for signs of wear. If any wear is evident, replace pin and bearing.
2. Check the pin and bearing for signs of heat discoloration. If excessive (heavily blued), replace both.
3. Check the bearing cage for excessive wear. Check the rollers for signs of flat spots. If found, replace pin and bearing.

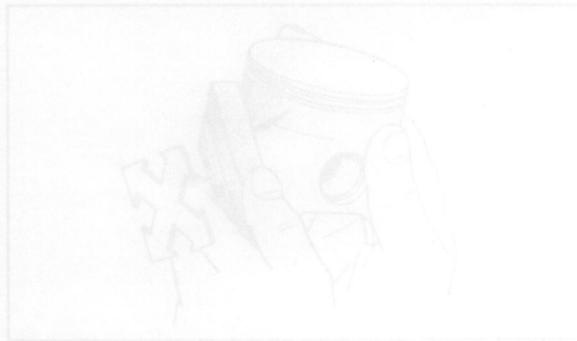
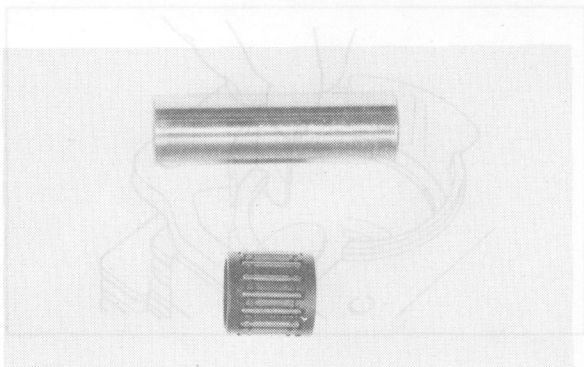

Piston outside diameter measurement
 1. To measure a cutaway piston, measure across the skirts at height "H" (just above the intake skirt cutaway) as shown in illustrations 1 and 2. Record this partial measurement.

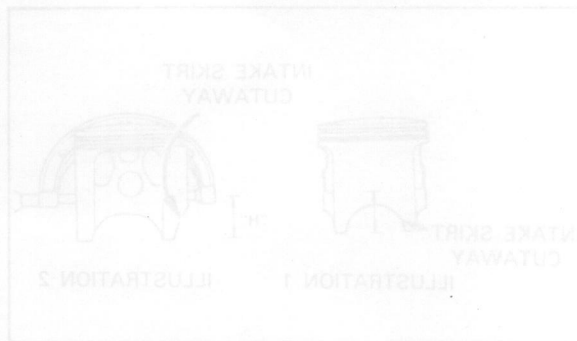

2. Add to this Partial Measurement (PM) the Adjustment Amount (AA) in the following table (PP + AA = piston diameter). The result will be the piston diameter. Use this figure to compute piston-to-cylinder clearance.

ADJUSTMENT AMOUNT (AA)	HEIGHT "H"
0 mm (0 in)	10 mm (0.3937 in)

Remember: Partial measurement + adjustment amount = piston diameter.
 Example: 88.950 mm (3.42 in) + 0 mm (0 in) (IT490K) = 88.950 mm (3.42 in) piston diameter.
 Do not try to measure from one of the intake "fingers" to the exhaust skirt. The piston will appear to be undersize. This is due to piston cam grind.

CLUTCH

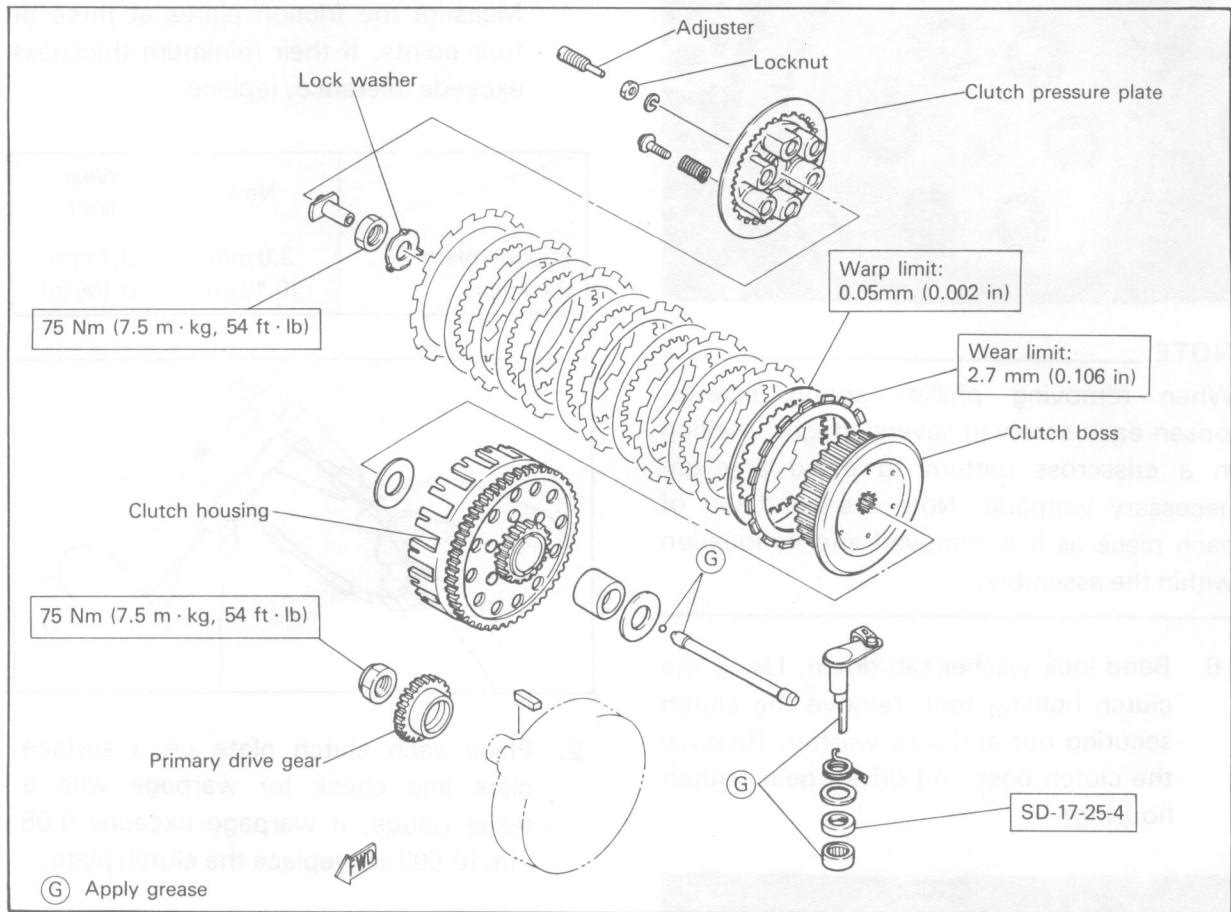

Removal

1. Drain the transmission oil.
2. Remove the right side engine guard.

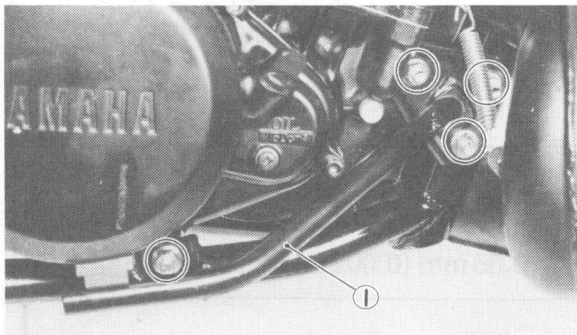

1. Engine guard

3. Remove the rear brake adjuster and remove the footrest. Remove the kick starter lever.

4. Remove the allen bolts holding the side cover in place and remove the cover. Note the position of the dowel pins.

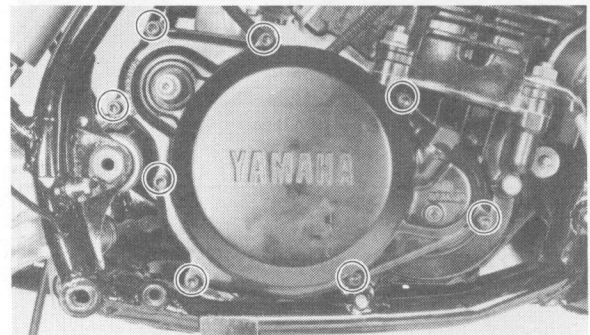

5. Remove the phillips screws (6) holding the pressure plate. Remove the clutch springs, pressure plate and push rod. Remove the clutch plates and friction plates.

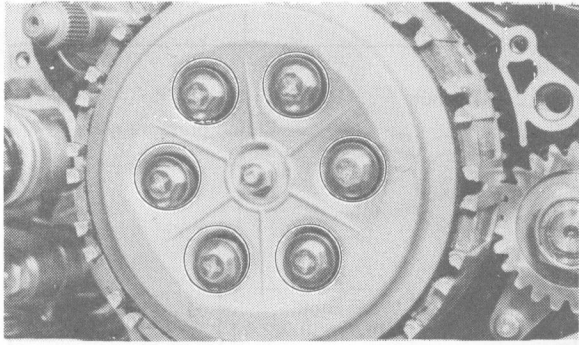

NOTE:

When removing phillips spring screws, loosen each screw in several stages working in a crisscross pattern to avoid any unnecessary warpage. Note the condition of each piece as it is removed and its location within the assembly.

6. Bend lock washer tab down. Using the clutch holding tool, remove the clutch securing nut and lock washer. Remove the clutch boss and driven gear (clutch housing).

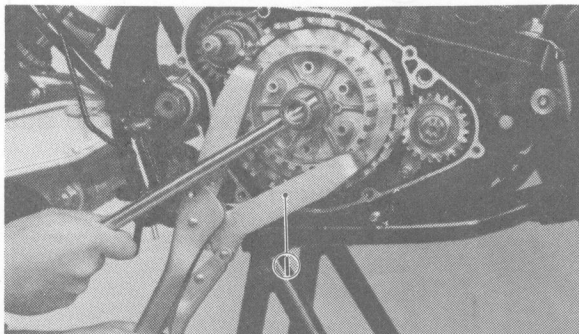

1. Clutch holding tool (YM-91042)

Clutch lock nut torque:
75 Nm (7.5 m · kg, 54 ft · lb)

Primary drive gear nut torque:
75 Nm (7.5 m · kg, 54 ft · lb)

Maintenance

1. Measure the friction plates at three or four points. If their minimum thickness exceeds tolerance, replace.

	New	Wear limit
Friction plate thickness	3.0 mm (0.12 in)	2.7 mm (0.106 in)

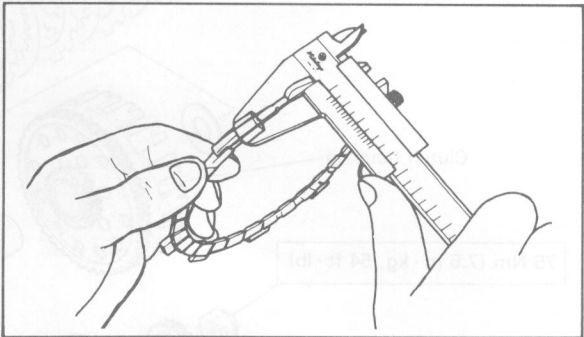

2. Place each clutch plate on a surface plate and check for warpage with a feeler gauge; if warpage exceeds 0.05 mm (0.002 in), replace the clutch plate.

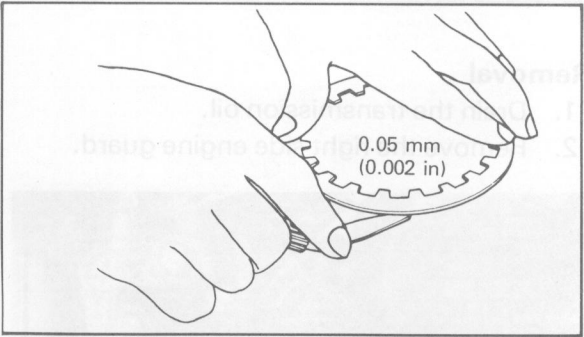

Clutch plate warpage allowance:
0.05 mm (0.002 in) Maximum

- Inspect the clutch hub and the outer clutch for wear as shown; if the wear is excessive, replace the component.

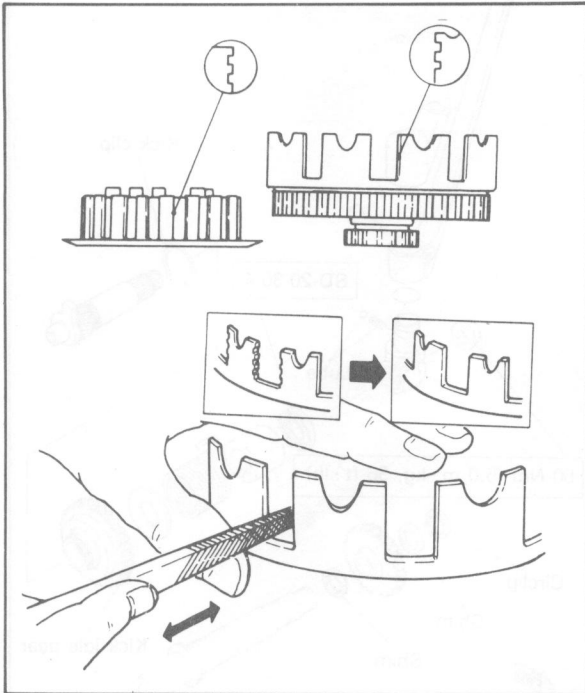

- Measure each clutch spring; if the free length of a spring is less than minimum length, replace the spring as a set.

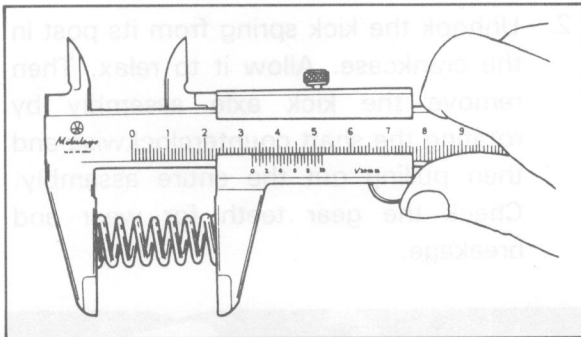

		New	Min.
Clutch spring free length	IT490K	35.5 mm (1.4 in)	34.5 mm (1.36 in)
	IT250K	31.2 mm (1.23 in)	30.2 mm (1.19 in)

Installation

- When installing the clutch lock nut, always use a new lock washer. After tightening the lock nut to the specification, be sure to lock it with the lock washer.

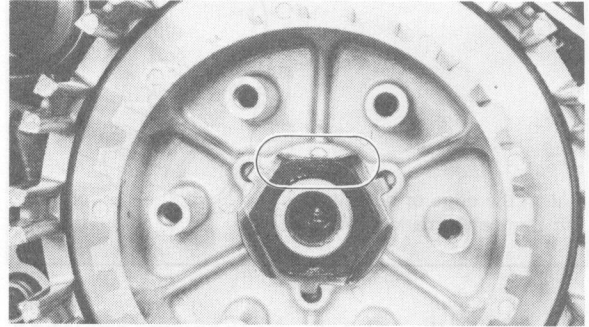

- When installing the clutch pressure plate, align arrow mark on clutch boss and pressure plate mark.

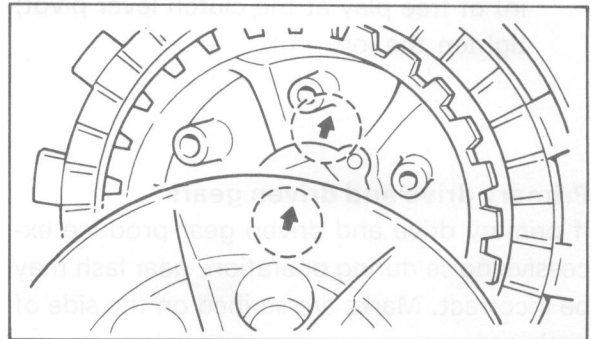

3. Mechanism adjustment

- Loosen the clutch mechanism adjuster lock nut, and loosen the adjusting screw.

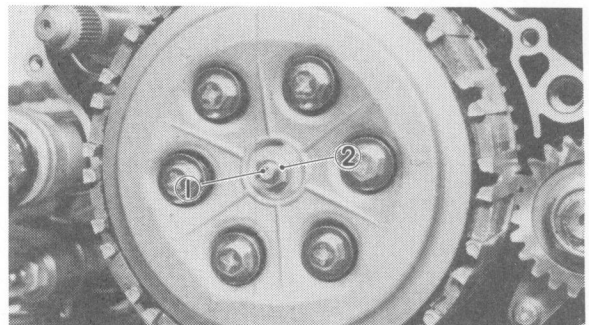

1. Adjuster 2. Lock nut

- b. At the handle lever, loosen the cable adjuster lock nut and adjust the cable length to align the match mark on the left-hand crankcase with the edge of the push lever.

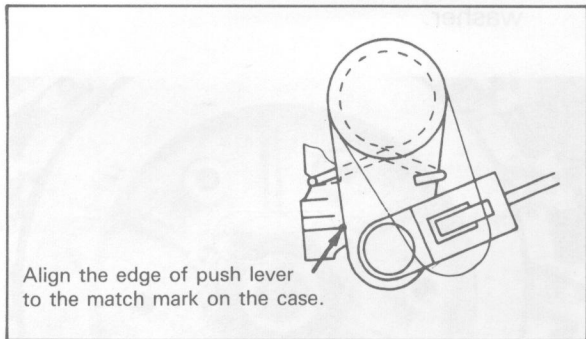

- c. Turn the clutch mechanism adjusting screw in until resistance is felt, and tighten the adjuster lock nut.
- d. Adjust the cable adjuster at the handle lever to provide 2 ~ 3 mm (0.08 ~ 0.12 in) of free play at the clutch lever pivot; tighten the lock nut.

Primary drive and driven gears

If primary drive and driven gear produce excessive noise during operation, gear lash may be incorrect. Marks are scribed on the side of each gear.

And in replacement, a gear having the same mark as before must be used.

KICK STARTER

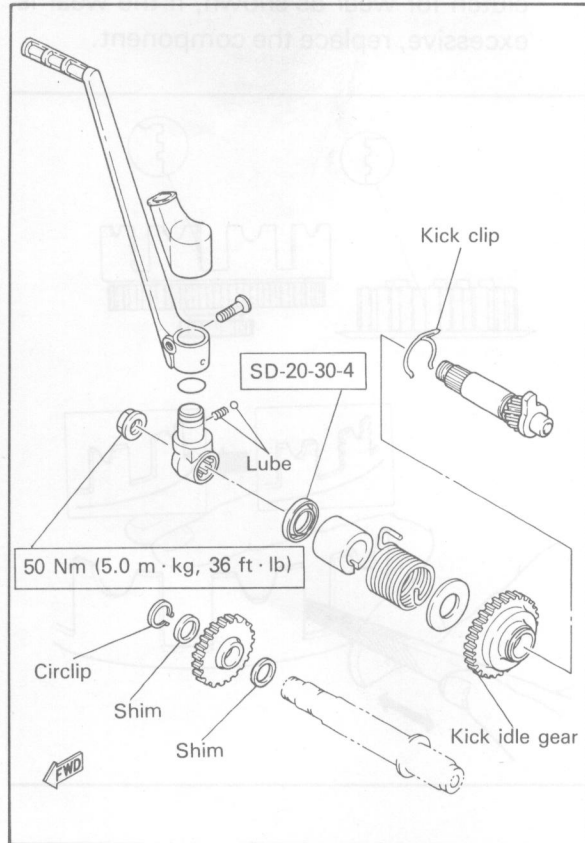

Removal

1. Remove circlip and kick idle gear.
2. Unhook the kick spring from its post in the crankcase. Allow it to relax. Then remove the kick axle assembly by rotating the shaft counterclockwise and then pulling out the entire assembly. Check the gear teeth for wear and breakage.

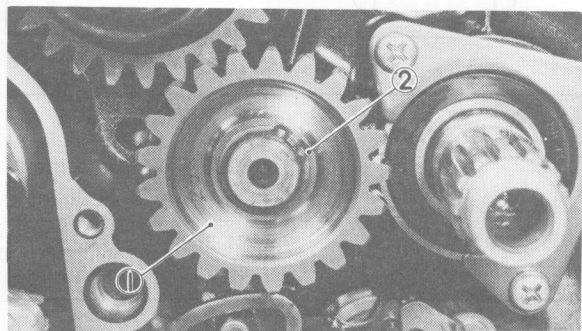

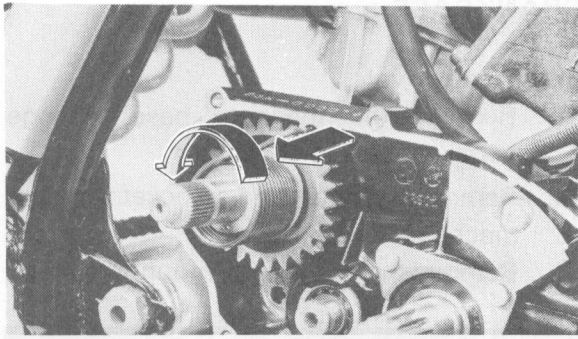

Inspection

1. Inspect the kick stopper on the end of kick axle; if it is damaged, replace the axle.
2. The pressure required to move the kick clip on the kick gear should be about 1.0 kg (2.2 lb). If the pressure required is more or less than this amount, the kick starter will malfunction; the kick clip must be replaced.

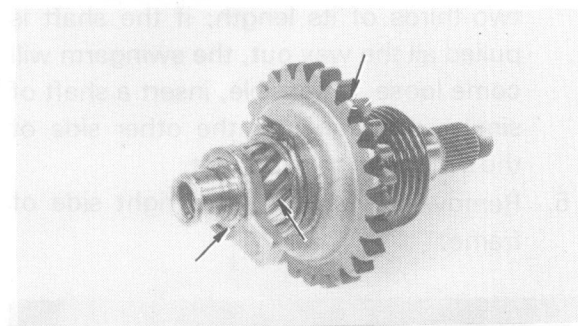
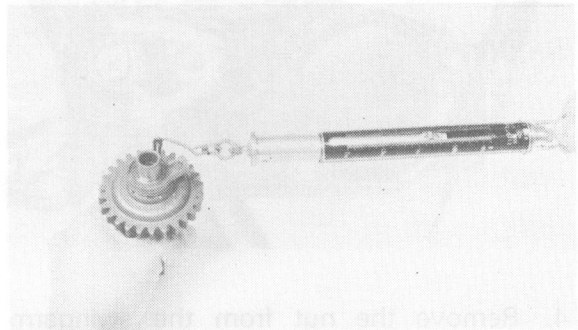

Reassembly

1. Slide the shaft into the case; make sure the kick clip fits into its boss in the crankcase.

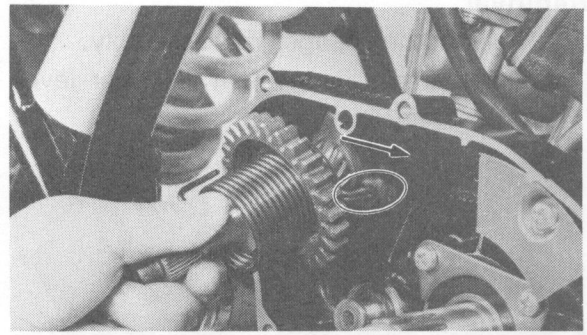

2. Turn the kick starter return spring clockwise and insert the hook into the proper hole in the crankcase.
3. After installing, check to make sure the kick gear engages and disengages properly with the idle gear.

SHIFTER

NOTE:

Shifter maintenance should be performed with clutch assembly removed.

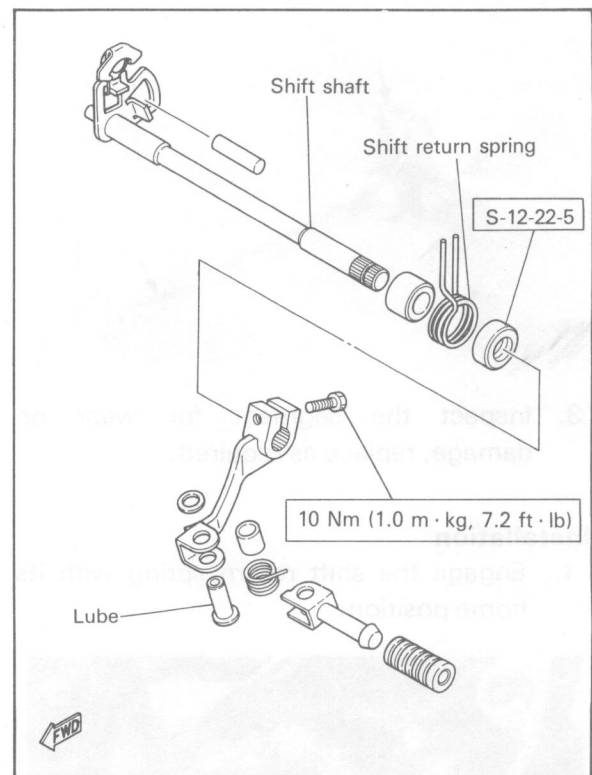

Removal

1. Pull out the change lever assembly.
2. Remove the flange bolt, stopper lever and spring.

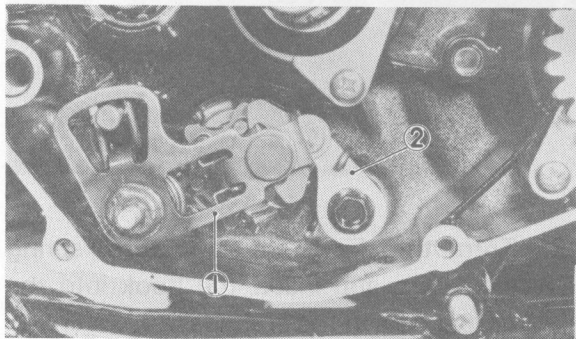

1. Change lever assembly 2. Stopper lever

Inspection

1. Inspect shift return spring. A broken or worn spring will impair the return action of the shifting mechanism.
2. Inspect change shaft assembly for bending of shaft, worn or bent spline, and broken or worn shift arm spring. A bent shaft will cause hard shifting.

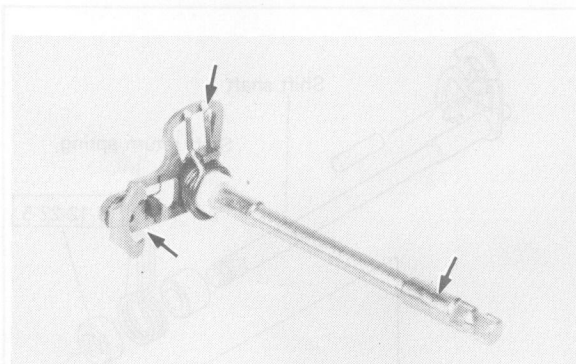

3. Inspect the segment for wear or damage, replace as required.

Installation

1. Engage the shift return spring with its home position.

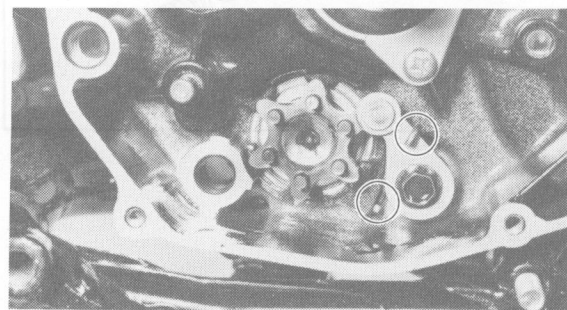

CRANKCASE

Engine removal

1. Remove the magneto base, change pedal, and chain cover.
2. Remove the chain and sprocket from the machine.
3. Remove the two engine mounting bolts.

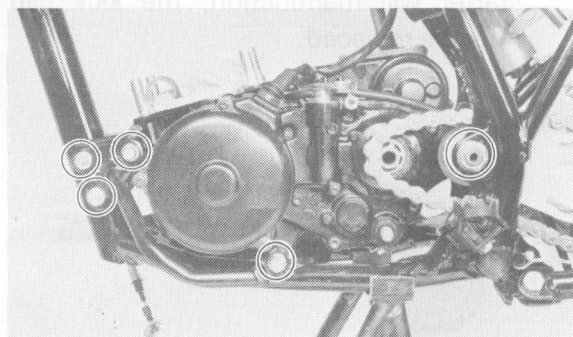
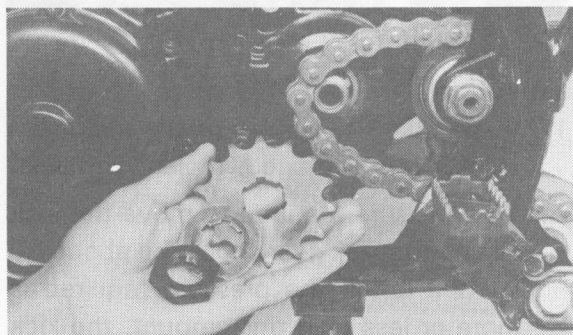

4. Remove the nut from the swingarm pivot shaft, and pull the shaft out about two-thirds of its length; if the shaft is pulled all the way out, the swingarm will come loose. If possible, insert a shaft of similar diameter into the other side of the swingarm to support it.
5. Remove the engine from right side of frame.

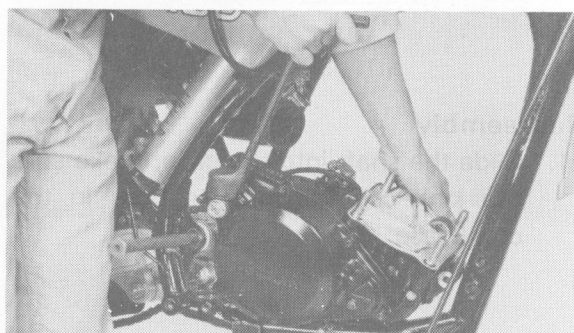

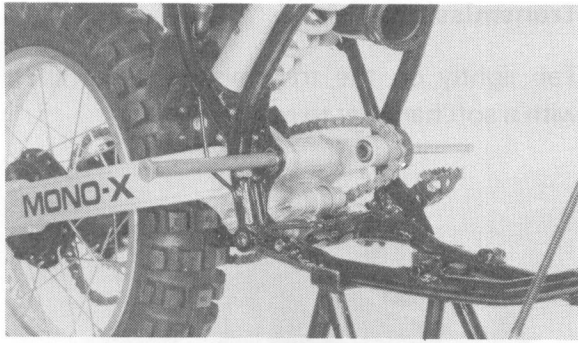

Mounting

1. Install engine mounting bolts and nuts with proper tightening torque.

Bolt	Tightening Torque
Bracket to frame	30 Nm (3.0 m·kg, 22 ft·lb)
Rear upper to engine	65 Nm (6.5 m·kg, 47 ft·lb)
Center, Lower	30 Nm (3.0 m·kg, 22 ft·lb)

Pivot shaft nut:
85 Nm (8.5 m·kg, 60 ft·lb)

After tightening the nut, grease the swing arm pivot shaft.

2. Install drive sprocket.

Drive sprocket nut torque:
75 Nm (7.5 m·kg, 54 ft·lb)

3. Install flywheel magneto.

Rotor nut torque:
80 Nm (8.0 m·kg, 56 ft·lb)

Crankcase disassembly

1. Working in a crisscross pattern, loosen panhead screws 1/4 turn each. Remove them after all are loosened.

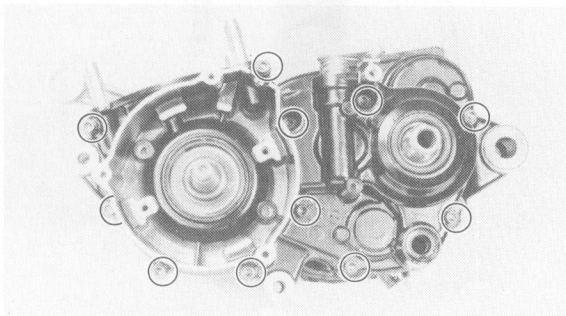

2. Before separating the crankcase, turn the segment to the position shown in the figure so that it does not contact the crankcase.

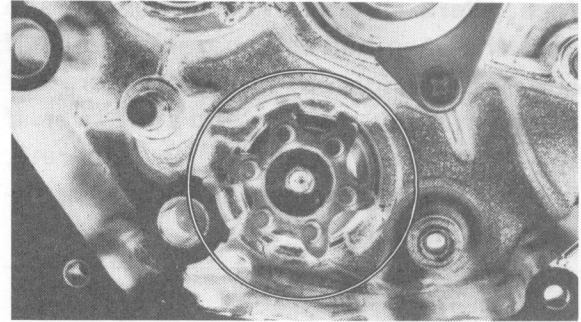

3. Remove the oil seal retainer. Install crankcase separating tool as shown.

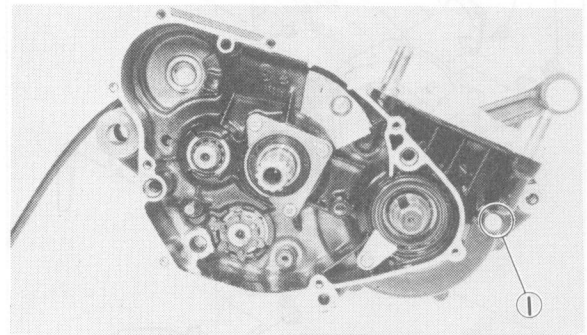

1. Retainer

NOTE:

Tighten the securing bolts on the crankcase separating tool, but make sure the tool body is parallel with the case. If necessary, one screw may be backed out slightly to level tool body.

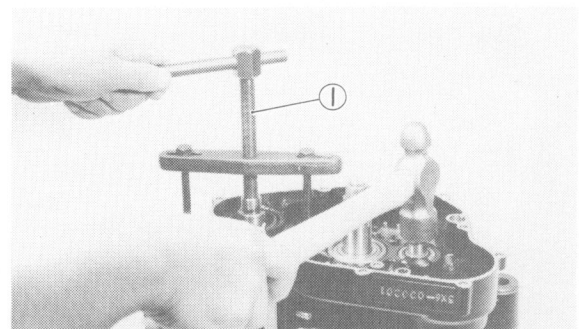

1. Crankcase separating tool

CAUTION:

Use a soft hammer to tap on the case half. Tap only on reinforced portions of case. Do not tap on gasket mating surface. Work slowly and carefully. Make sure the case halves separate evenly. If one end "hangs up," take pressure off the push screw, realign and start over. If the halves are reluctant to separate, check for a remaining case screw or fitting. Do not force.

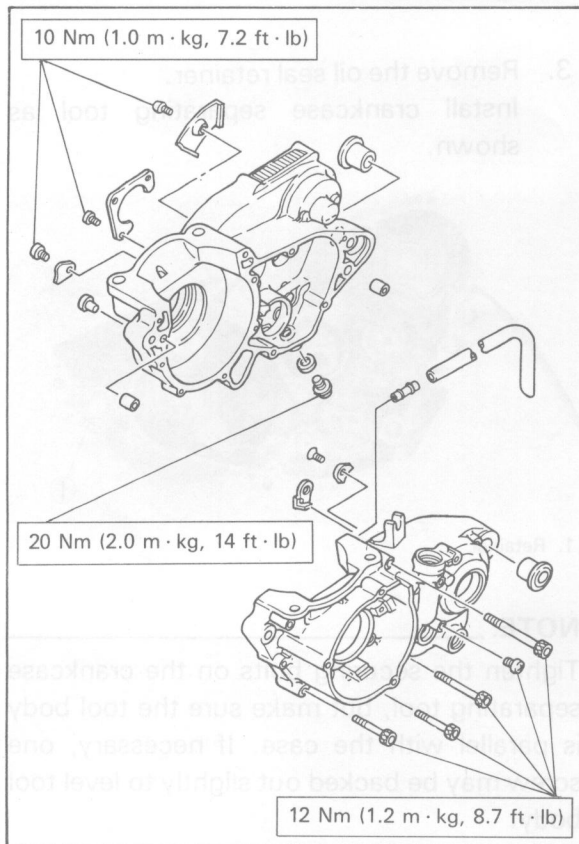

Transmission

Tap lightly on the transmission drive shaft with a soft hammer to remove.

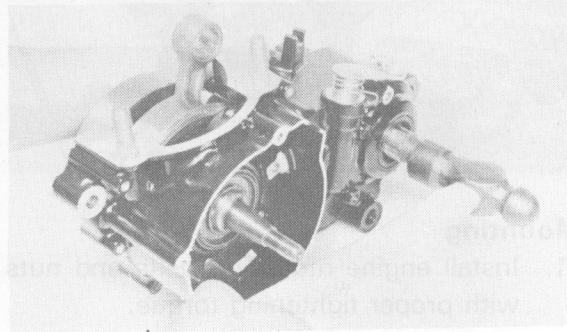

NOTE:

Remove assembly carefully. Note the position of each part. Pay particular attention to the location and direction of shift forks.

Inspection

1. Inspect each shift fork for signs of galling on gear contact surfaces. Check for bending. Make sure each fork slides freely on its guide bar.
2. Check the shift cam grooves for signs of wear or damage. If any profile has excessive wear and/or any damage, replace cam.
3. Check the cam followers on each shift fork for wear. The follower should fit snugly into its seat in the shift fork, but should not be overly tight. Check the ends that ride in the grooves in the shift cam. If they are worn or damaged, replace.

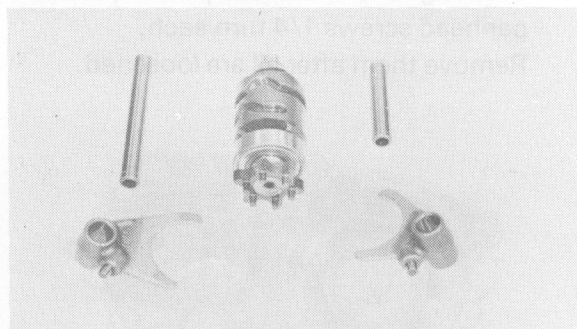

4. Check the shift cam stopper plate, circlip, stopper for wear.

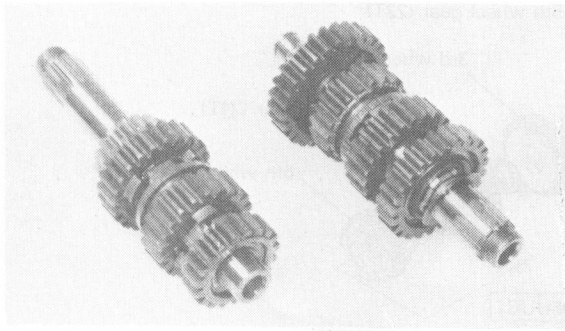

5. Carefully inspect each gear. Look for signs of obvious heat damage (blue discoloration). Check the gear teeth for signs of pitting, galling; or other extreme wear. Replace as required.
6. Check to see that each gear properly engages its counterpart on the shaft. Check the mating dogs for rounded edges, cracks, or missing portions. Replace as required.

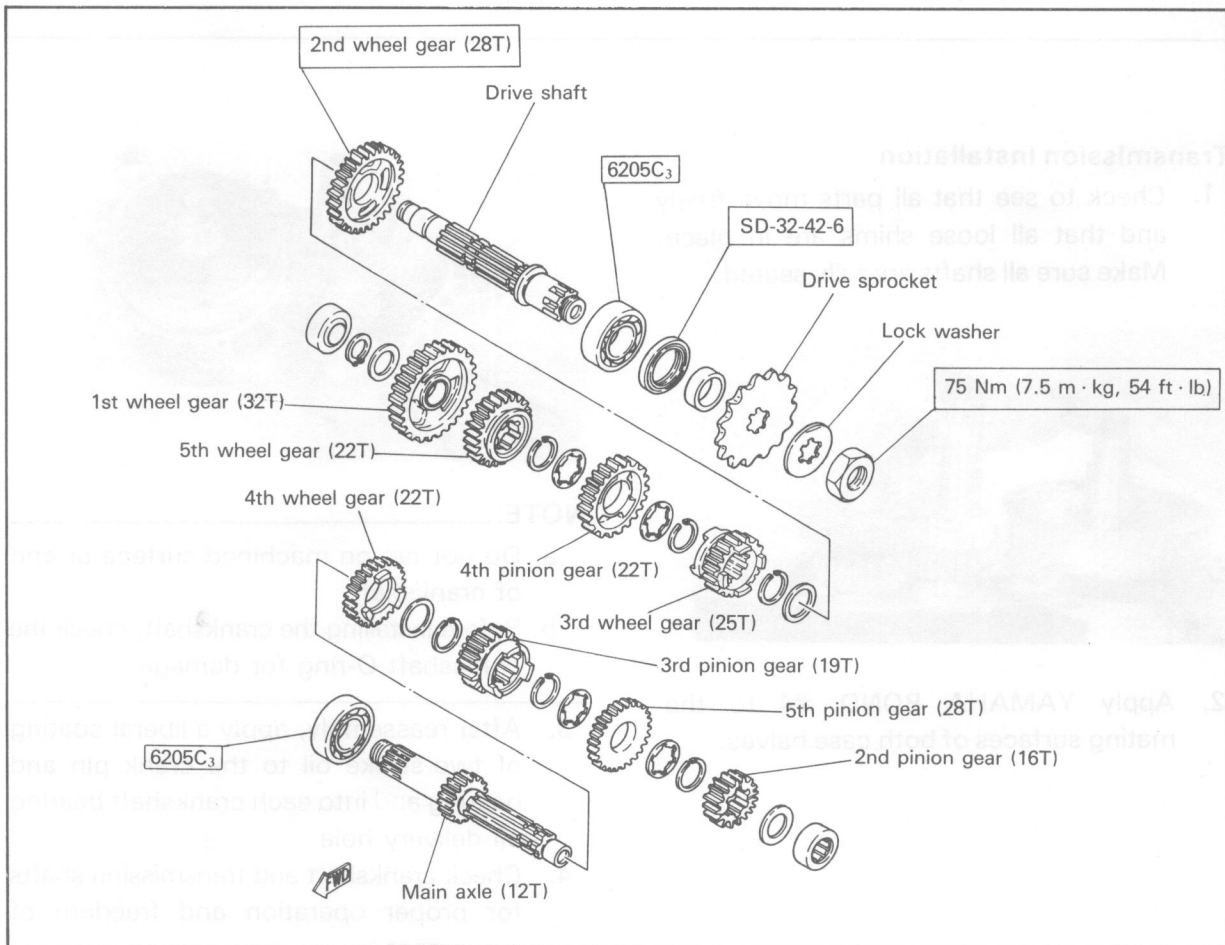
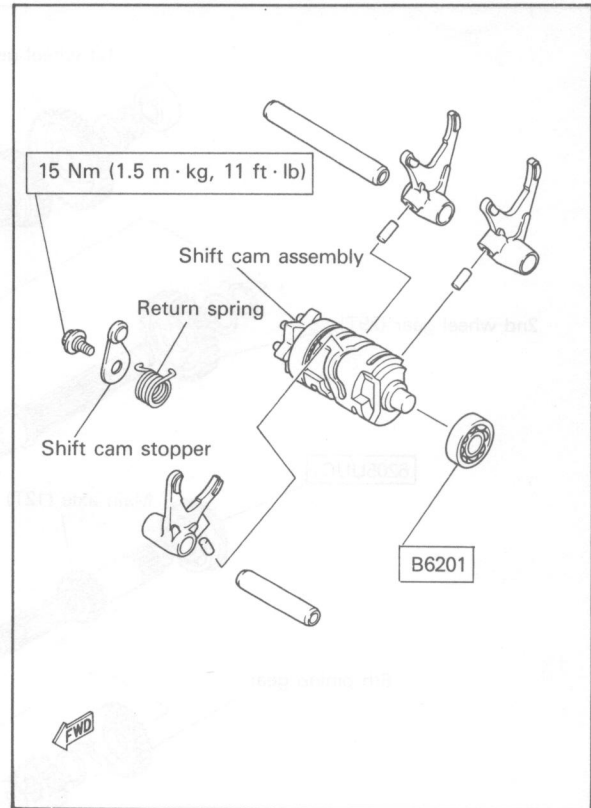

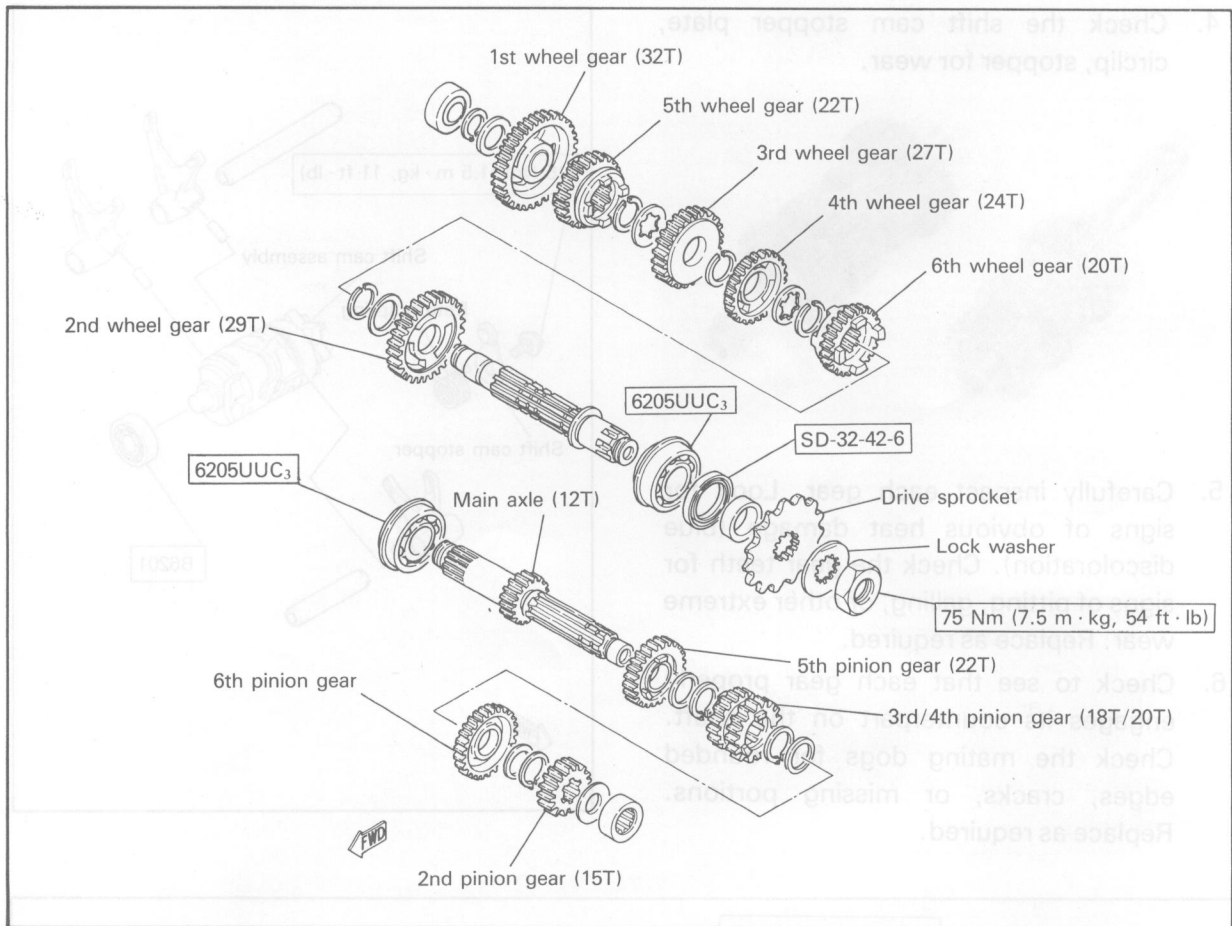

Transmission installation

1. Check to see that all parts move freely and that all loose shims are in place. Make sure all shafts are fully seated.

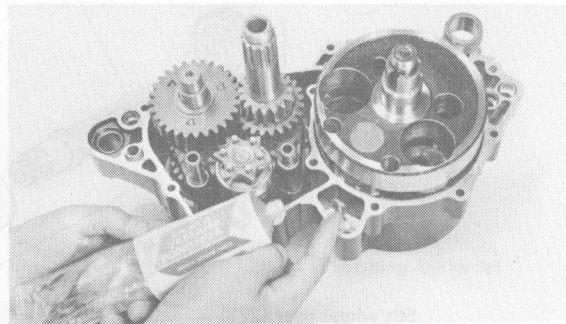
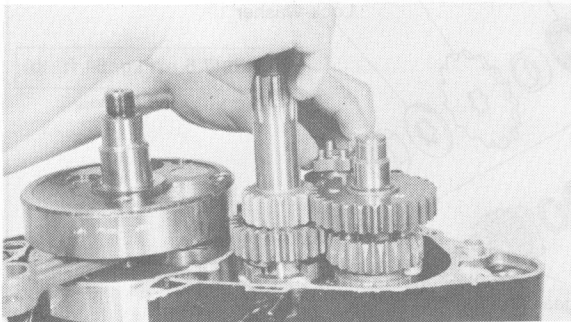

NOTE:

- a. Do not tap on machined surface or end of crankshaft.
 - b. Before installing the crankshaft, check the crankshaft O-ring for damage.
3. After reassembly, apply a liberal coating of two-stroke oil to the crank pin and bearing and into each crankshaft bearing oil delivery hole.
 4. Check crankshaft and transmission shafts for proper operation and freedom of movement.

Bearings and oil seals

1. After cleaning and lubricating the bearings, rotate inner race with a finger. If rough spots are noticed, replace the bearing.

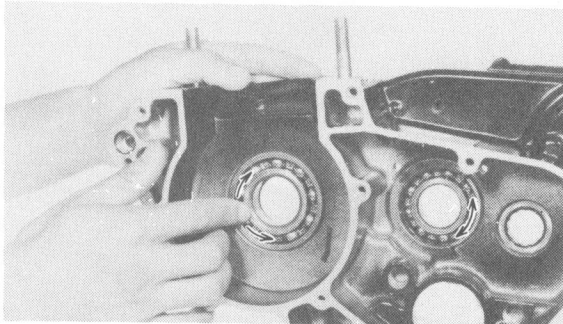

NOTE:

Bearing(s) are most easily removed or installed if the cases are first heated to approximately 90° ~ 120°C (194° ~ 248°F). Bring the case up to proper temperature slowly. Use an oven.

2. Check oil seal lips for damage or wear. Replace as required.
3. Always replace crankshaft oil seals whenever the crankshaft is removed.
4. Install bearing(s) and oil seal(s) with their manufacturer marks or numbers facing outward. Before installation, apply grease to oil seal lip(s) and bearing(s).

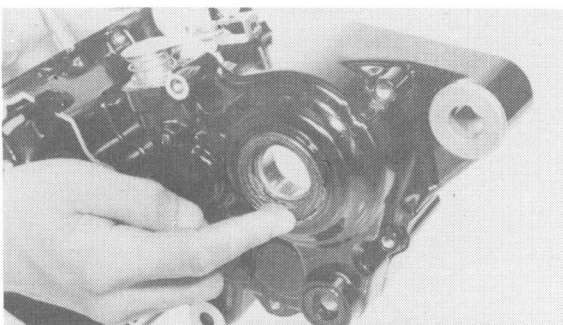

Crankshaft

1. Remove crankshaft assembly with crankcase separating tool.

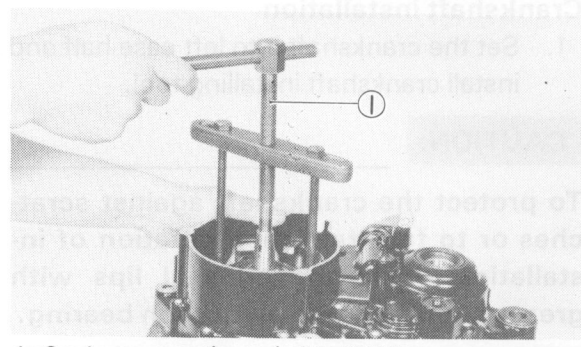

1. Crankcase separating tool (YU-01135)

Inspection

1. Check crankshaft components.

Connecting rod axial play (F):

0.4 ~ 1.0 mm (0.016 ~ 0.04 in)

«Maximum: 2.0 mm (0.08 in)»

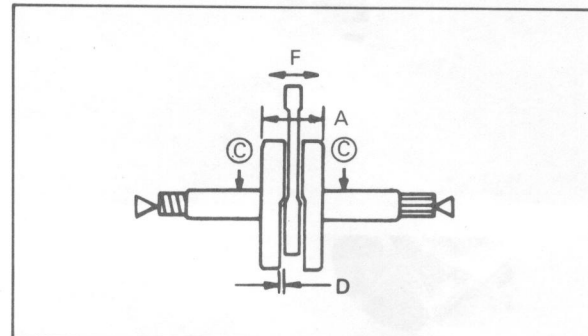

Connecting rod/crank side clearance (D):

0.25 ~ 0.75 mm (0.01 ~ 0.029 in)

Unit: mm (in)

Deflection tolerance (C)		Flywheel width (A)
Left side	Right side	
0.03 (0.0012)	0.03 (0.0012)	IT490K: 66 ⁺⁰ _{-0.05} (2.59 ⁺⁰ _{-0.02})
		IT250K: 62 ⁻⁰ _{-0.05} (2.44 ⁻⁰ _{-0.02})

Crankshaft installation

1. Set the crankshaft into left case half and install crankshaft installing tool.

CAUTION:

To protect the crankshaft against scratches or to facilitate the operation of installation: Pack the oil seal lips with grease. Apply engine oil to each bearing.

2. Hold the connecting rod at top dead center with one hand while turning the handle of the installing tool with the other. Operate tool until crankshaft bottoms against bearing.

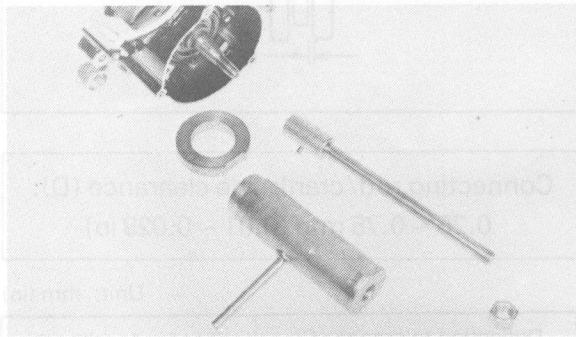
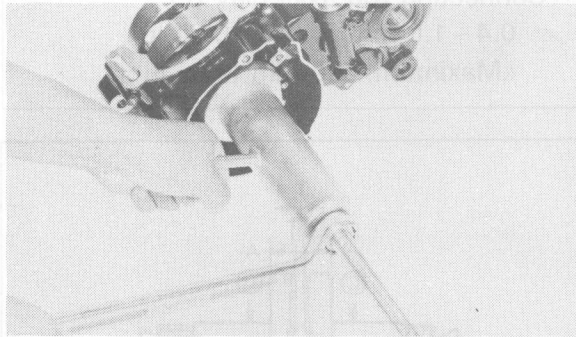

	Right side	Left side
IT150K1	0.03	0.03
IT150K2	(0.0012)	(0.0012)

Bearings and oil seals
 1. After cleaning and lubricating the bearings, rotate inner race with a finger. If rough spots are noticed, replace the bearing.

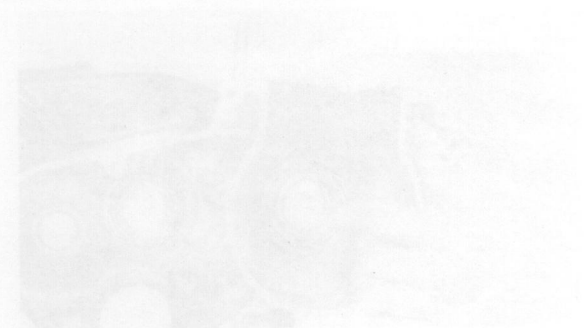

NOTE:
 Bearings are most easily removed or installed if the cases are first heated to approximately 90°C (194°F) - 120°C (248°F). Bring the case up to proper temperature slowly. Use an oven.

2. Check oil seal lips for damage or wear. Replace as required.
3. Always replace crankshaft oil seals whenever the crankshaft is removed.
4. Install bearing(s) and oil seal(s) with their manufacturer marks or numbers facing outward. Before installation, apply grease to oil seal lip(s) and bearing(s).

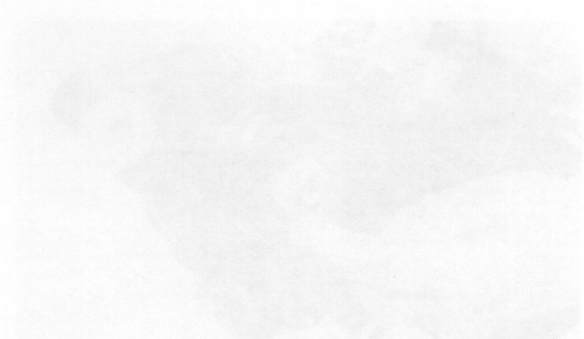

Crankshaft
 1. Remove crankshaft assembly with crankcase separating tool.

4 CHASSIS MAINTENANCE AND REPAIR

WHEEL ASSEMBLIES AND SPROCKETS	4-1
Wheel installation	4-2
Rims and spokes	4-3
Bearings	4-3
Brake shoe inspection	4-3
Brake shoe adjustment	4-3
Brake cam lever	4-3
Brake drum	4-4
Sprockets	4-4
FRONT FORK	4-5
Front fork setting	4-5
Fork oil	4-5
Fork spring	4-5
Fork tube height	4-5
Air pressure	4-6
Handling note	4-6
Fork oil replacement	4-6
Disassembly and inspection	4-7
Reassembly	4-8
STEERING HEAD	4-10
Inspection	4-11
REAR SHOCK (MONOCROSS SUSPENSION "DE CARBON" SYSTEM)	4-11
Rear shock setting	4-11
Spring preload (Installed length)	4-12
Shock spring	4-12
Rebound damping	4-12
Nitrogen gas	4-12
Handling notes	4-12
Notes on disposal (Yamaha dealers only)	4-13
Removal	4-13
SWINGARM	4-15
Inspection	4-15

4 CHASSIS MAINTENANCE AND REPAIR

WHEEL ASSEMBLIES AND SPROCKETS

Whenever performing chassis work, always take extra care and double-check each step of each procedure. The wheels, brakes, suspension, steering, and frame must all be in top condition to provide optimum performance, reliability, and safety.

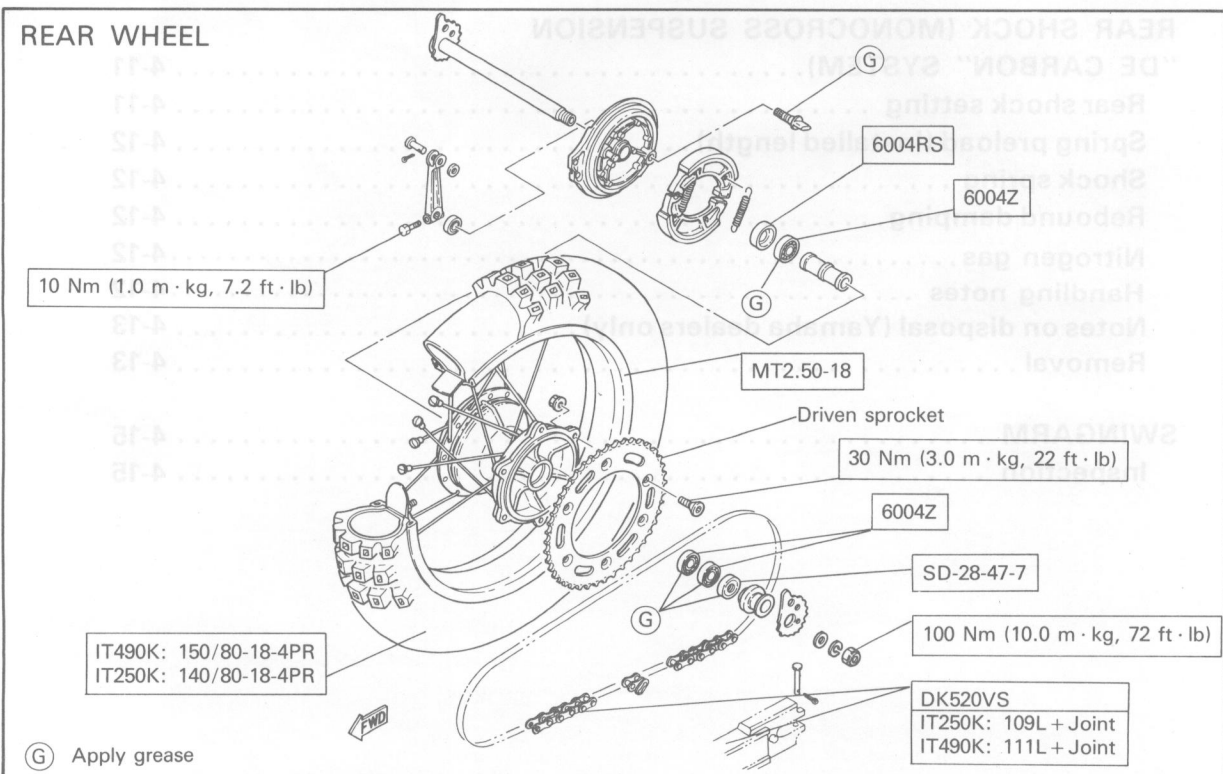
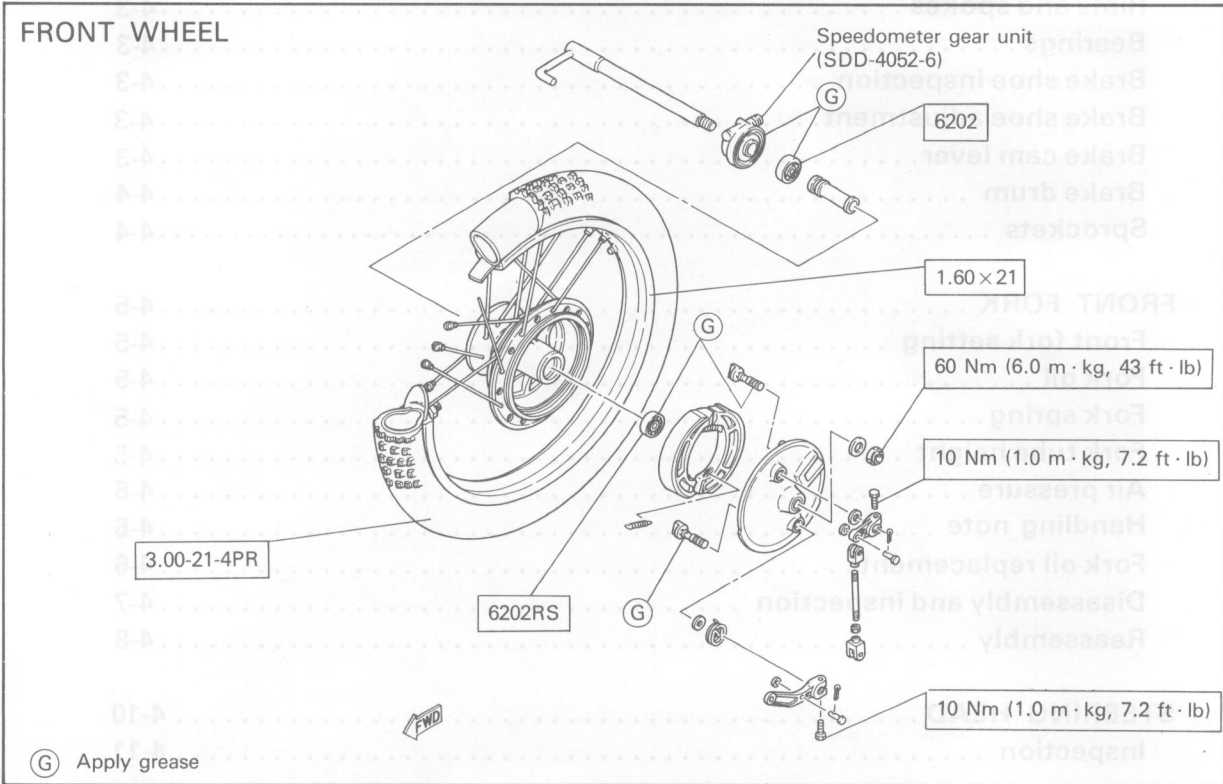

Wheel installation

When installing wheels, reverse the removal procedure taking care of the following points.

1. Lightly smear grease on:
 - * The shafts
 - * The bearings and oil seal lips
 - * The O-ring and dust cover interior for the rear brake shoe plate
 - * The oil seal and collar outer circumference from the torque arm.
2. Make sure the three slots in the wheel hub are meshed with the three projections in the speedometer cable housing.

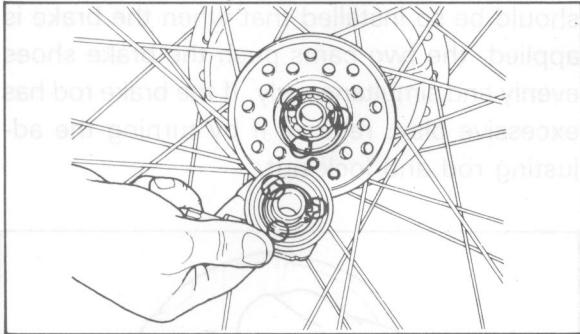

3. Check for proper engagement of the boss on the outer tube (Swingarm) with the locating slot on the brake shoe plate.

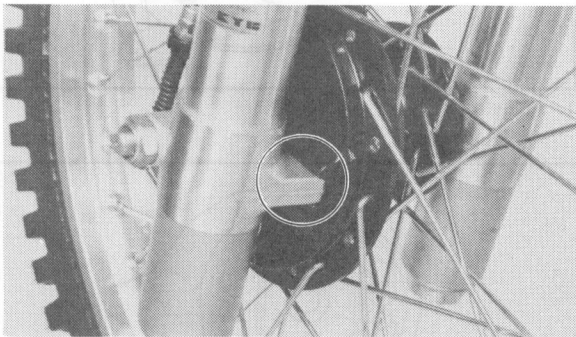

4. Make sure nuts are properly tightened.

Front wheel axle:

60 Nm (6.0 m · kg, 43 ft · lb)

Axe pinch bolts:

20 Nm (2.0 m · kg, 14 ft · lb)

Rear wheel axle:

100 Nm (10.0 m · kg, 72 ft · lb)

NOTE:

- a. After installing the wheel, rotate it freely and apply the brake.
- b. With the brake applied, tighten the axle nut.
- c. Contract the front forks several times, and while keeping them contracted, tighten the axle pinch bolt.

5. Always use new cotter pins. Old pins should be discarded.
6. Be sure to adjust the tension of the chain. (Refer to "DRIVE CHAIN")
7. Adjust the plays in the brake lever and pedal.

Rims and spokes

1. Block the wheels off the ground.
2. Spin the wheels and observe the amount of runout.
3. If the runout exceeds 2.0 mm (0.080 in), true the wheels.

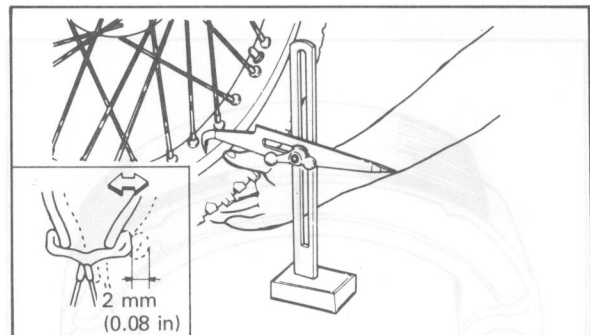
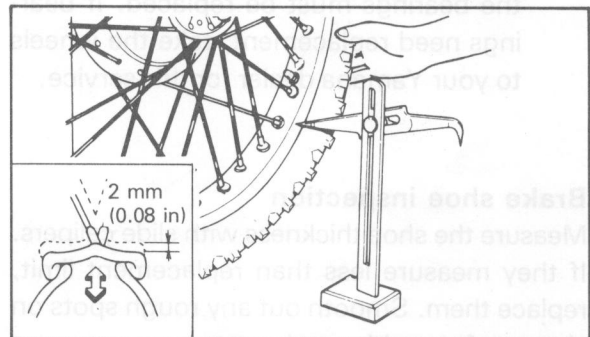

4. Tap each spoke with a spoke wrench to determine if any spokes are loose; tighten all loose spokes and replace bent spokes.

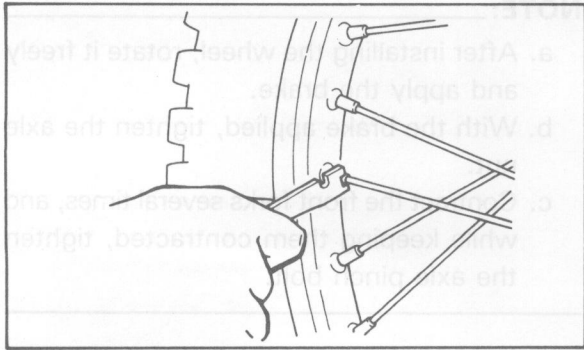

- If a rim is severely "dinged" or bent, replace the rim.

Bearings

- To inspect the wheel bearings, try to move the wheel sideways in relation to the fork in the front or the frame in the rear. If any movement is felt, the bearings must be replaced.
- Block the wheels off the ground and spin each wheel. If the wheels do not spin freely with the brakes disengaged, the bearings must be replaced. If bearings need replacement, take the wheels to your Yamaha dealer for this service.

Brake shoe inspection

Measure the shoe thickness with slide calipers. If they measure less than replacement limit, replace them. Smooth out any rough spots on shoe surface with sandpaper.

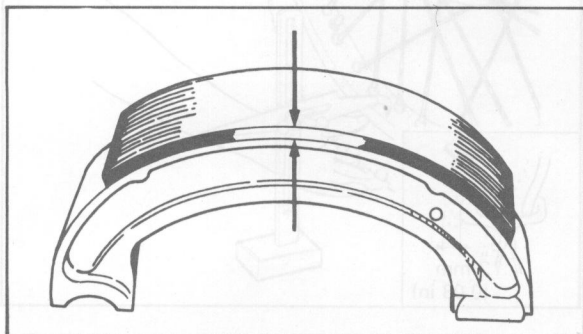

Standard thickness	Min. allowable thickness
4 mm (0.16 in)	2 mm (0.08 in)

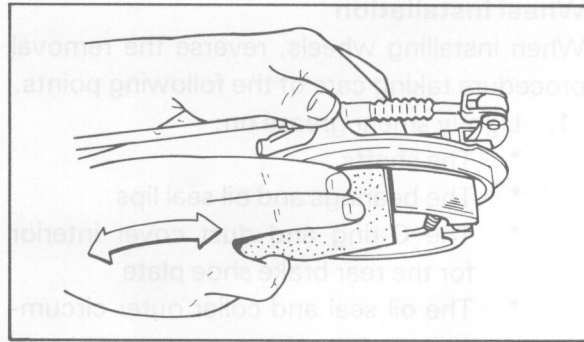

Brake shoe adjustment

On the two leading shoe brake, the cam lever should be so installed that when the brake is applied, the two cams push the brake shoes evenly and simultaneously. If the brake rod has excessive play, remove it by turning the adjusting rod and lock nut.

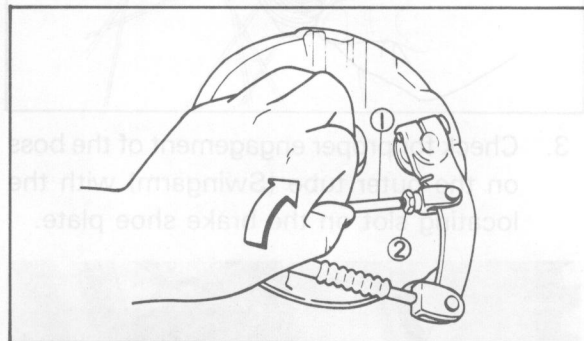

1. Adjuster 2. Locknut

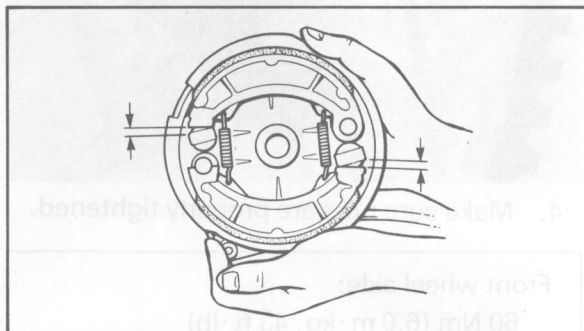

Brake cam lever

When removing the brake cam lever from the shaft, put match marks on both the cam lever and the shaft. The marks will be of great help when the brake is reassembled.

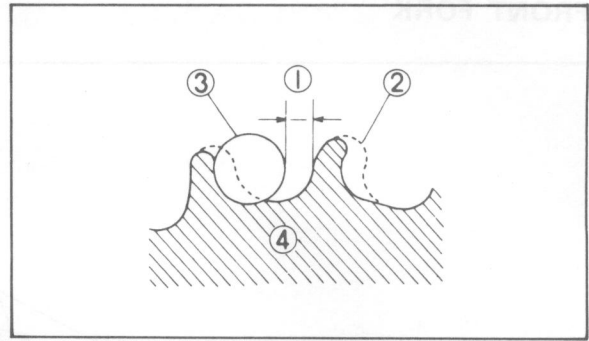
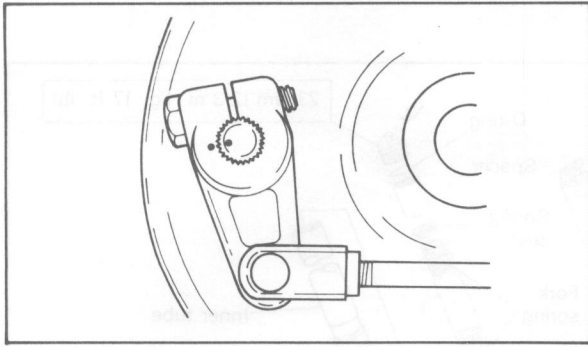

1. 1/4 tooth 2. Correct 3. Roller 4. Sprocket

Brake drum

Inspect the brake drum; if there is any oil or dirt on the inner surface, wipe the drum clean with a rag dampened with lacquer thinner or solvent. If the drum is deeply grooved, the drum must be replaced.

Drive sprocket securing nut torque:
75 Nm (7.5 m · kg, 54 ft · lb)

Driven sprocket securing nut torque:
30 Nm (3.0 m · kg, 22 ft · lb)

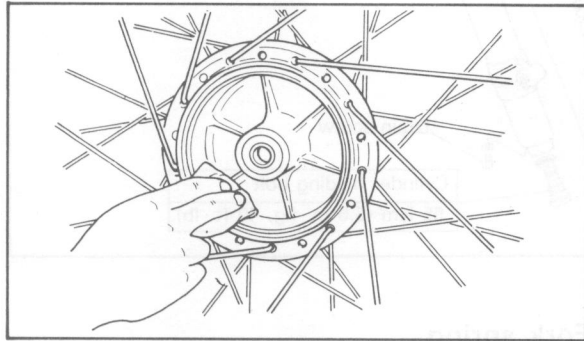

- When replacing the drive sprockets, always use a new lock washer. After tightening the sprocket nut to the specification, be sure to lock it with the lock washer.

Sprockets

- Inspect the teeth on the rear sprocket; if they are worn as shown in the illustrations below, replace the sprockets and chain as a set.

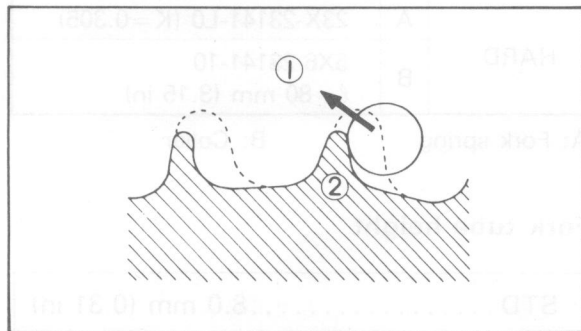
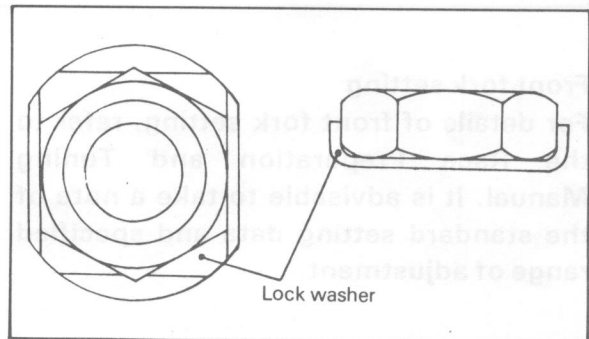

1. Slip off 2. Bend teeth

- When installing the driven sprocket, lightly smear grease on the fitting bolts.

FRONT FORK

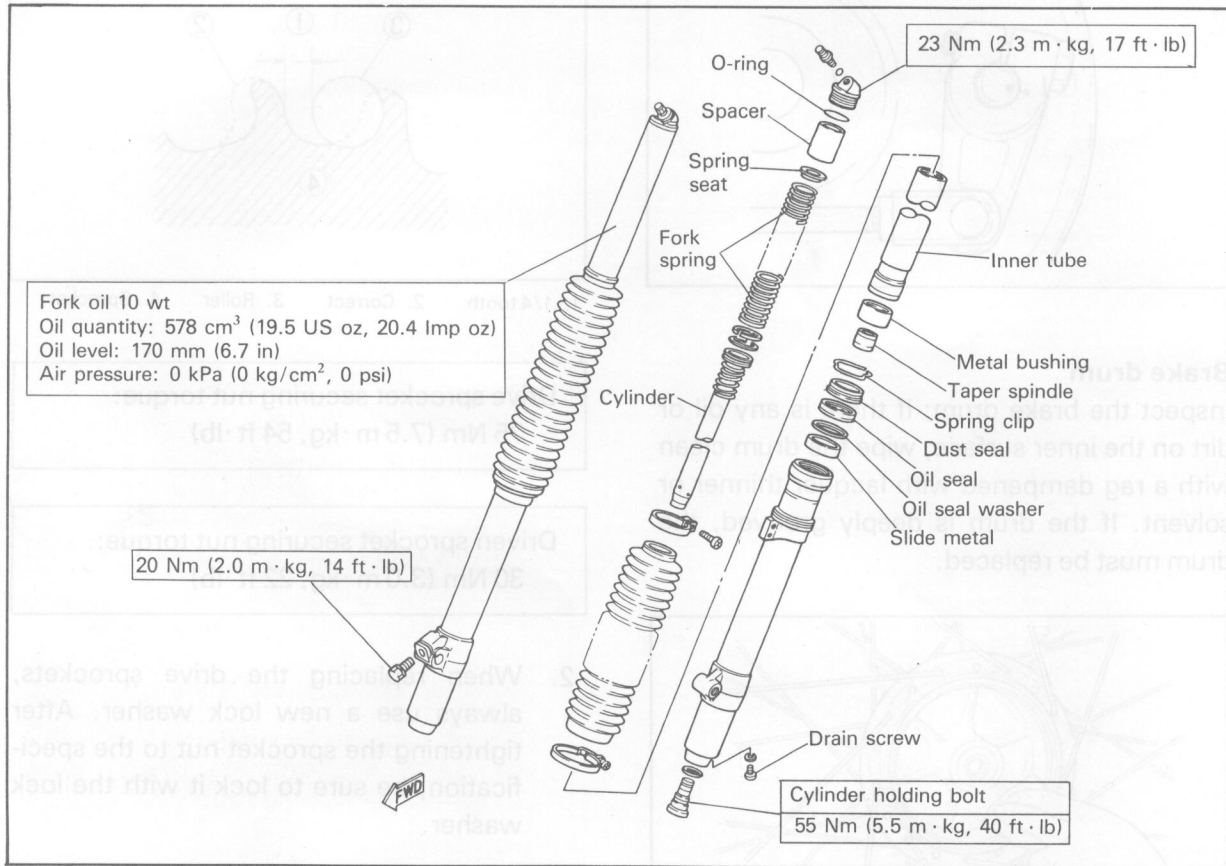

Front fork setting

For details of front fork setting, refer to the Race Preparation and Tuning Manual. It is advisable to take a note of the standard setting data and specified range of adjustment.

Fork oil

Recommended oil: Yamaha fork oil 10 wt Oil quantity: 578 cm ³ (20.4 Imp oz, 19.5 US oz)
Oil level: STD 170 mm (6.69 in) MIN 150 mm (5.90 in) MAX 200 mm (7.87 in)

Fork spring

SOFT	A	23X-23141-10 (K = 0.275) One slit
	B	5X6-23118-10 ℓ = 80 mm (3.15 in)
STD	A	23X-23141-M0 (K = 0.290)
	B	5X6-23118-M0 ℓ = 110 mm (4.33 in)
HARD	A	23X-23141-L0 (K = 0.305)
	B	5X6-23141-10 ℓ = 80 mm (3.15 in)

A: Fork spring

B: Collar

Fork tube height

STD 8.0 mm (0.31 in)
MIN 0 mm (0 in)
MAX 10 mm (0.39 in)

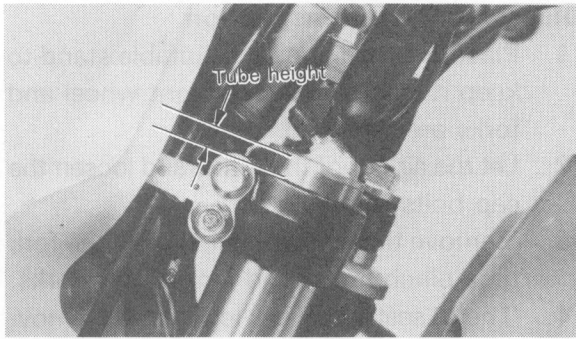

Air pressure

STD	0 kPa (0 kg/cm ² , 0 psi)
MAX.	117.7 kPa (1.2 kg/cm ² , 17 psi)

Handling note

CAUTION:

To prevent an accidental explosion of air, the following instructions should be observed:

1. Use only air or nitrogen for filling. Never use any other gas. An explosion may result.
2. Never throw the front fork into fire.
3. Before removing the cap bolts or front forks, be sure to extract the air from the air chamber completely.

1. After running over a dusty or sandy course, remove the dust cover and remove the dust around the front forks. This cleaning will protect the fork oil seals against damage.

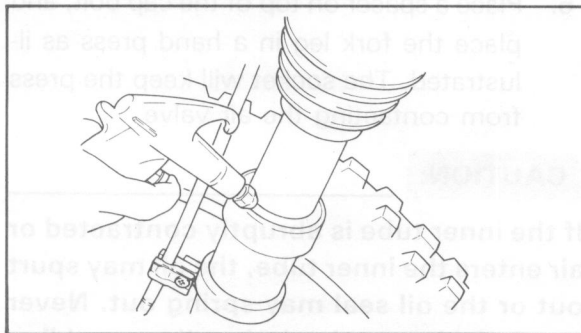

2. Before removing the front forks, put the marks, R and L, on the tops of cap bolts, so you will not be confused when re-installing the front forks.

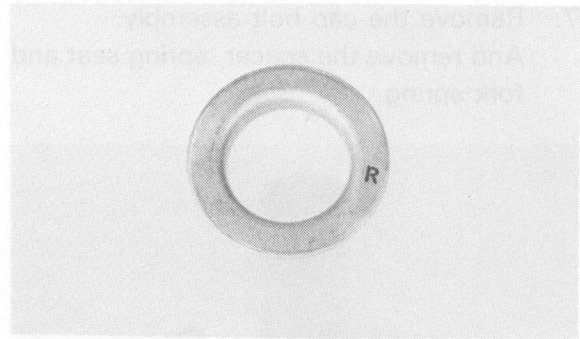

Fork oil replacement

1. Remove the handlebar.
2. Remove the valve cap and depress the air valve to allow the air to escape from the fork legs.

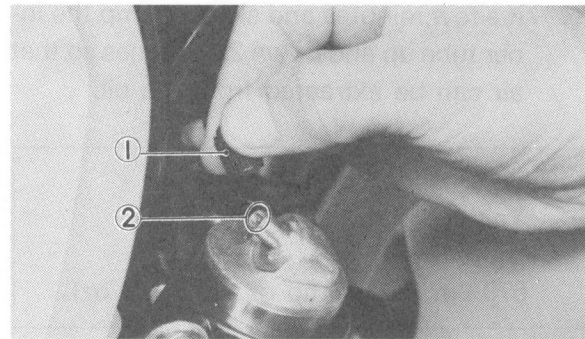

1. Valve cap 2. Valve

3. Place an open container beneath each drain hole and remove the drain screws.

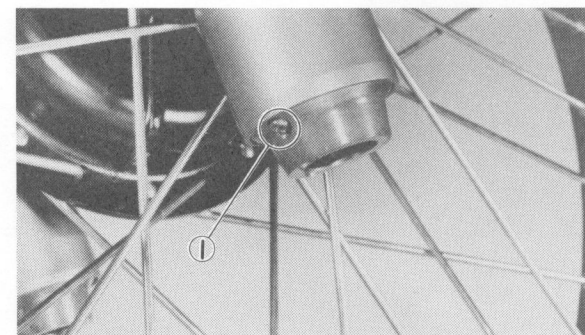

1. Drain screw

4. After most of oil has drained, slowly raise and lower outer tubes to pump out remaining oil.
5. Install drain screws.

NOTE:

Check gasket, replace if damaged.

6. Place a suitable stand under the engine to keep the front of machine raised off the floor.

- Remove the cap bolt assembly.
And remove the spacer, spring seat and fork spring.

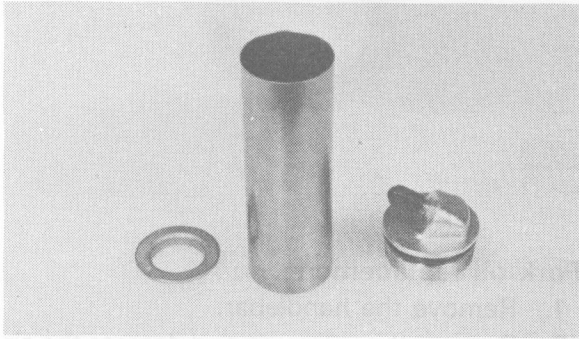

- Measure the correct amount of oil and pour it into each leg. After filling, allow it a few minutes and slowly pump the inner tube up and down 2 or 3 times so that air can be extracted from the oil.

Recommended oil:

Yamaha fork oil 10 wt

Oil quantity:

578 cm³ (20.4 Imp oz, 19.5 US oz)

- Inspect the O-ring on the cap bolt; if it is cut or otherwise damaged, replace the O-ring.

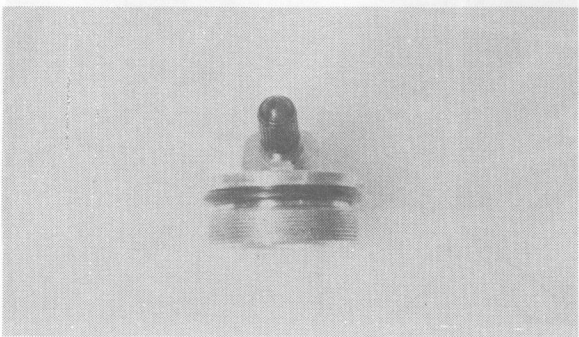

- Install spacer, spring seat, fork spring and cap bolt and torque to specification.

Tightening torque:

23 Nm (2.3 m·kg, 17 ft·lb)

Disassembly and inspection

- Place the machine on a suitable stand to keep it stable while the front wheel and forks are removed.
- Let the air out of the forks, and loosen the cap bolts slightly.
- Remove the front wheel, loosen the fork tube pinch bolts, and remove the forks.
- The oil seal in the fork leg must be removed hydraulically. Fill the fork completely with fork oil and reinstall the cap bolt. Depress the air valve until oil flows out.
- Remove the snap ring from the top of the slider.

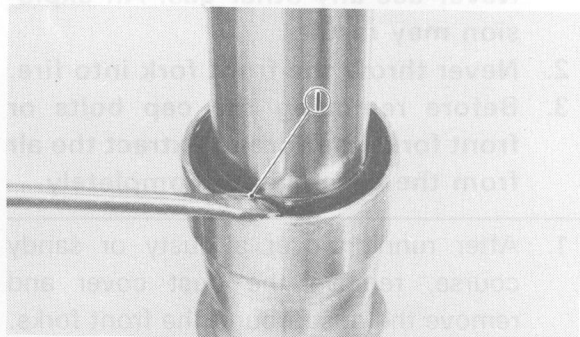
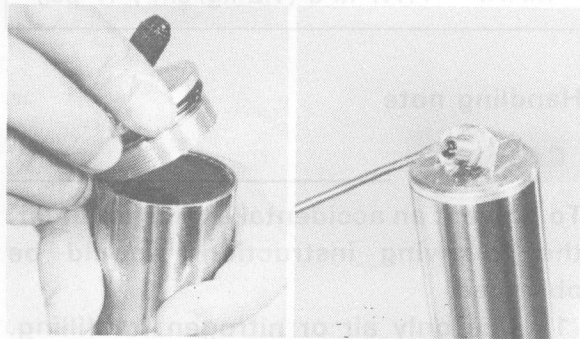

1. Snap ring

- Place a spacer on top of the cap bolt, and place the fork leg in a hand press as illustrated. The socket will keep the press from contacting the air valve.

CAUTION:

If the inner tube is abruptly contracted or air enters the inner tube, the oil may spurt out or the oil seal may spring out. Never touch the inner tube during disassembling operation. Also wrap the oil seal with a rag for safety.

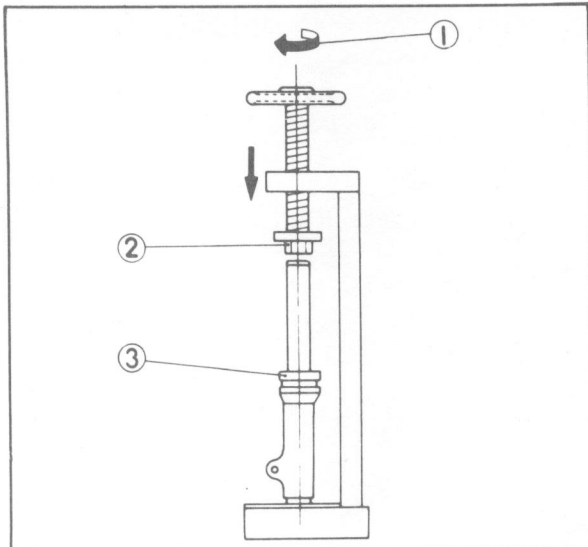

1. Turn slowly 2. Spacer 3. Wrap with rag

7. Wrap a rag around the top of the slider, and slowly turn the handle of the press until the oil seal is pushed out of the slider.
8. Remove the dust seal, and oil seal. Discard the oil seal, as the seal must always be replaced whenever the fork is disassembled.
9. Remove the oil seal washer and slide metal, and inspect the slide metal; if it shows excessive wear, replace the slide metal.
10. Clamp the axle lug in a vise, and push the inner tube all the way into the slider.
11. Use the damping-cylinder holding tool to remove the holding bolt from the bottom of the slider.

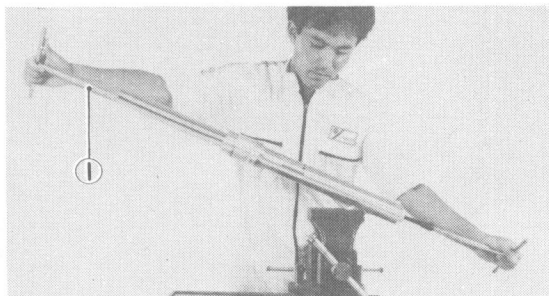

1. Cylinder holding tool (YM-01327, 01326)

NOTE:

The holding bolt is locked with LOCTITE®. To remove it, tap it with a hammer several times so that it can be loosened.

12. Remove the fork leg from the vise and hold it parallel to the ground while removing the slider from the inner tube.

Reassembly

The assembly procedure is the reverse of the disassembly procedure.

1. Make sure all components are clean before assembly. Always install a new fork seal. Do not re-use a seal.
2. Apply Loctite to the threads of the bolt, and reinstall the bolt. Using the damping-cylinder holding tool, torque the holding bolt to specification.

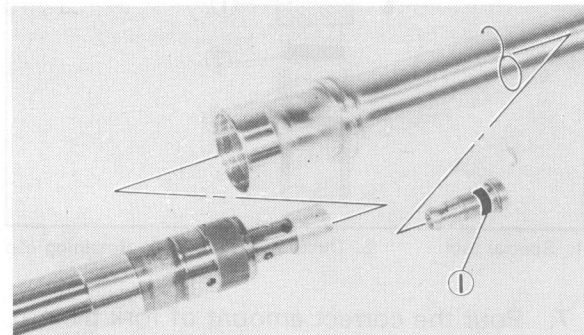
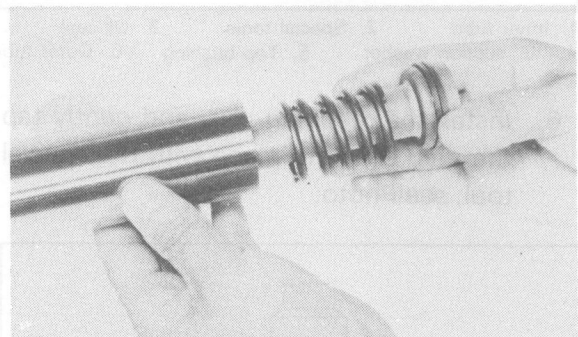

1. Apply Loctite®

Holding bolt torque:
55 Nm (5.5 m · kg, 40 ft · lb)

3. Install the guide bushing in the special 43 mm (1.7 in) fork tool (P/N YM-08020).

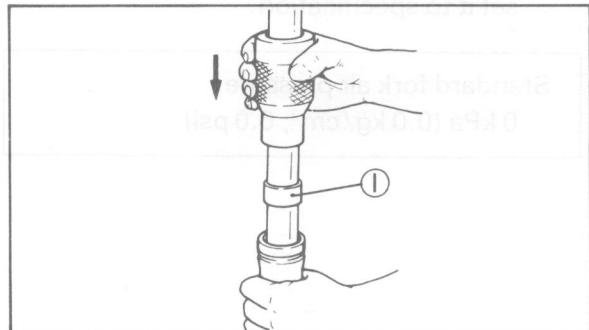

1. Top Bushing

4. Install a new seal spacer, making sure the beveled edge faces upward.
5. Oil and install a new oil seal in the top of the slider with the special tool; see Photo.

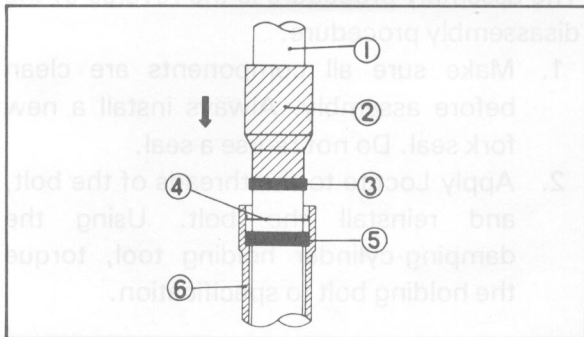

1. Inner tube
2. Special tools
3. Oil seal
4. "L" section washer
5. Top bushing
6. Outer tube

6. Install the retaining clip, and gently tap the dust seal into place with the special tool; see Photo.

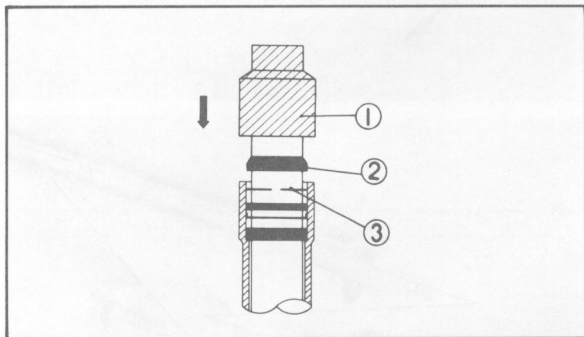

1. Special tool
2. Dust cover
3. Retaining clip

7. Pour the correct amount of fork oil into the fork leg, and pump the inner tube up and down to remove all air from the valving mechanism.
8. Use the fork oil level tool to attain the proper oil level with the tube pushed down.
9. Check the air pressure in the fork, and set it to specification.

Standard fork air pressure:
0 kPa (0.0 kg/cm², 0.0 psi)

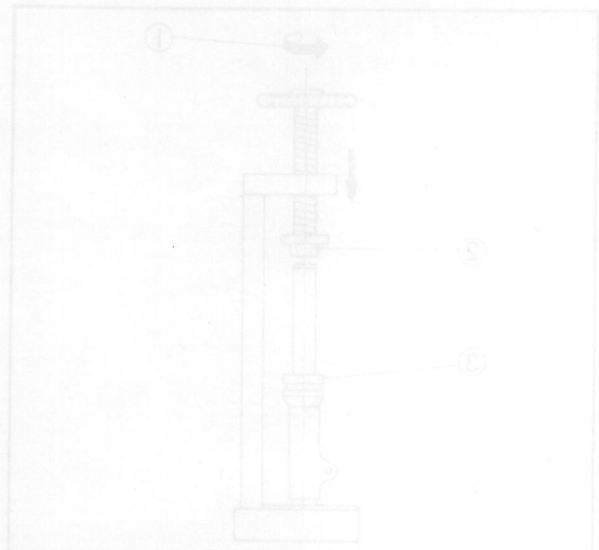

1. Turn slowly 2. Spacer 3. Wipe with rag

7. Wipe a rag around the top of the slider, and slowly turn the handle of the press until the oil seal is pushed out of the slider.
8. Remove the dust seal, and oil seal. Discard the oil seal, as the seal must always be replaced whenever the fork is disassembled.
9. Remove the oil seal washer and slide metal, and inspect the slide metal. If it shows excessive wear, replace the slide metal.
10. Clamp the axle lug in a vise, and push the inner tube all the way into the slider.
11. Use the damping-cylinder holding tool to remove the holding bolt from the bottom of the slider.



NOTE:
The holding bolt is locked with LOCTITE®. To remove it, tap it with a hammer several times so that it can be loosened.

STEERING HEAD
 (Adjustment begins on page 2-14 of
 chapter 2.)

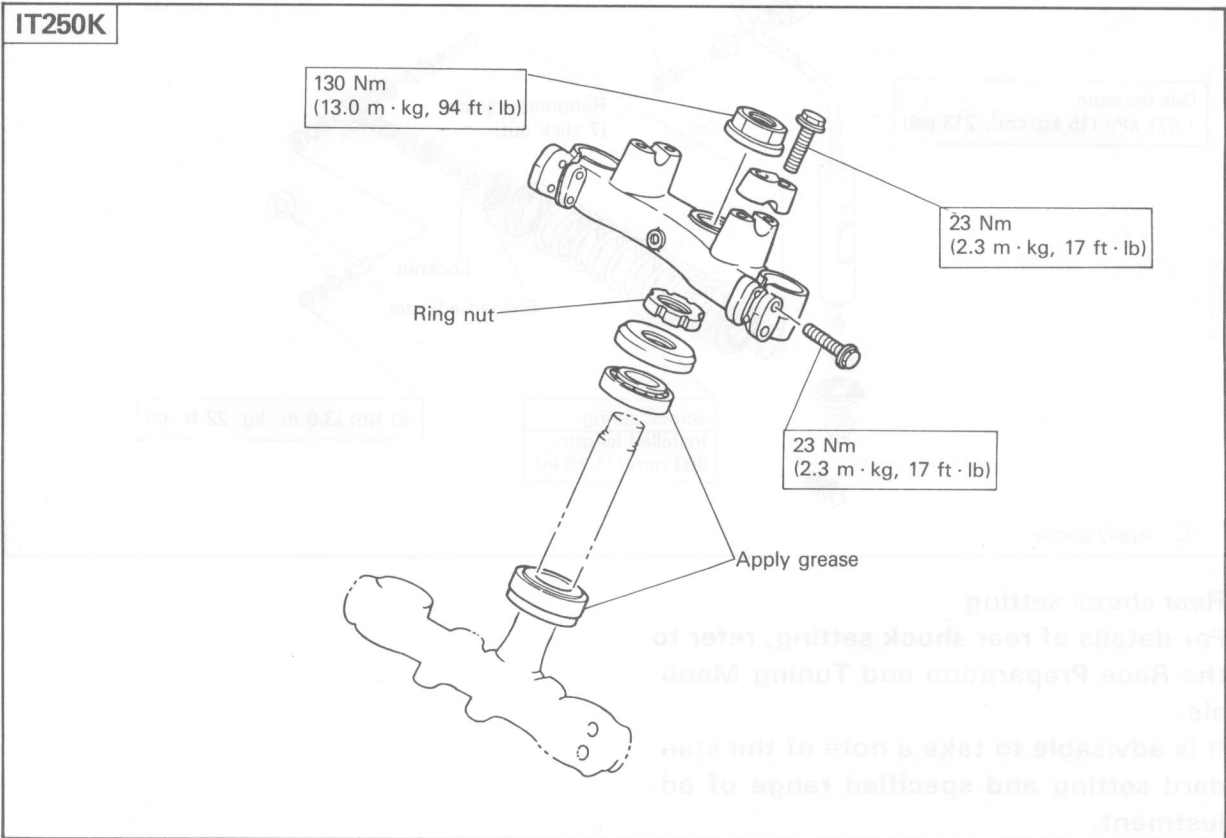
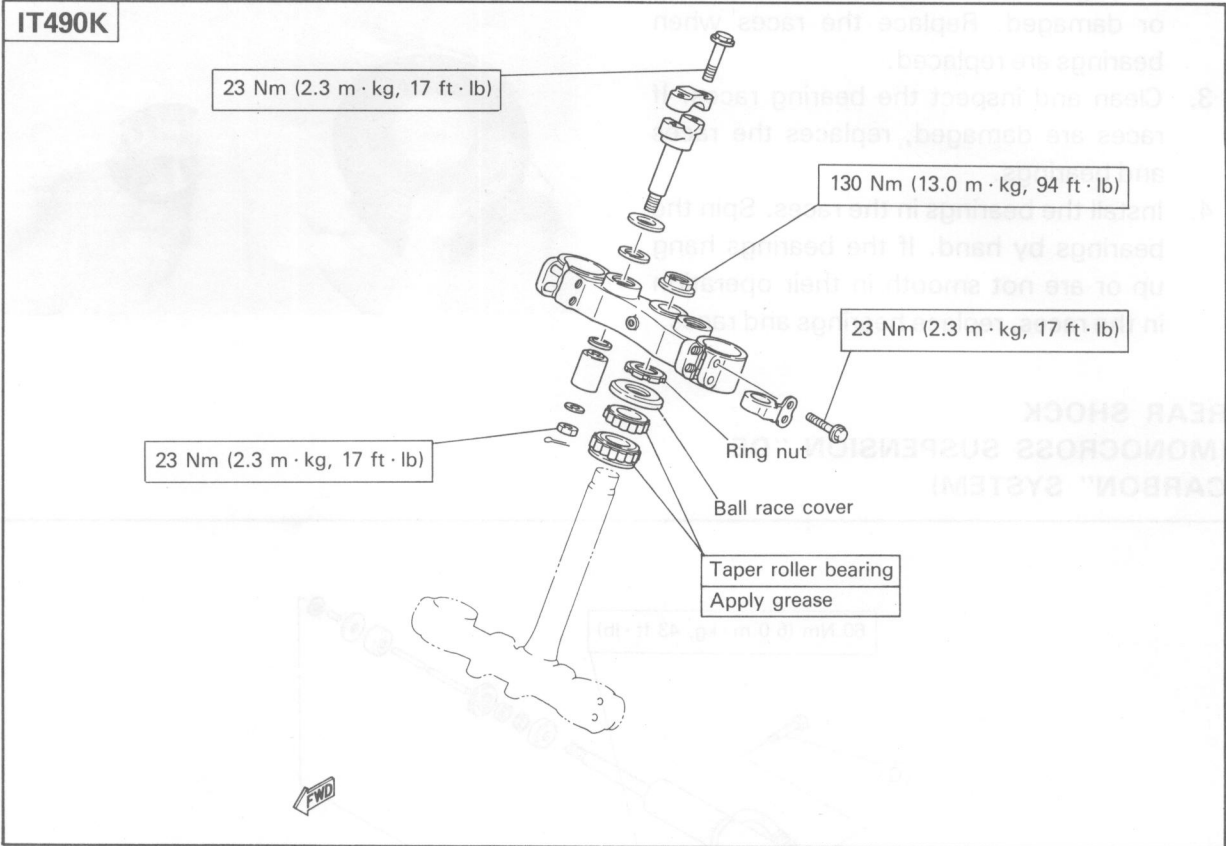

Inspection

1. Wash the bearings in solvent.
2. Inspect the bearings for pitting or other damage. Replace the bearings if pitted or damaged. Replace the races when bearings are replaced.
3. Clean and inspect the bearing races. If races are damaged, replace the races and bearings.
4. Install the bearings in the races. Spin the bearings by hand. If the bearings hang up or are not smooth in their operation in the races, replace bearings and races.

5. Coat the oil seal(s) and bearing(s) with high quality, lithium base grease before installing.

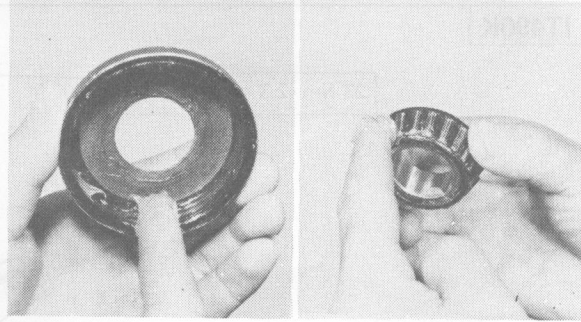

REAR SHOCK (MONOCROSS SUSPENSION "DE CARBON" SYSTEM)

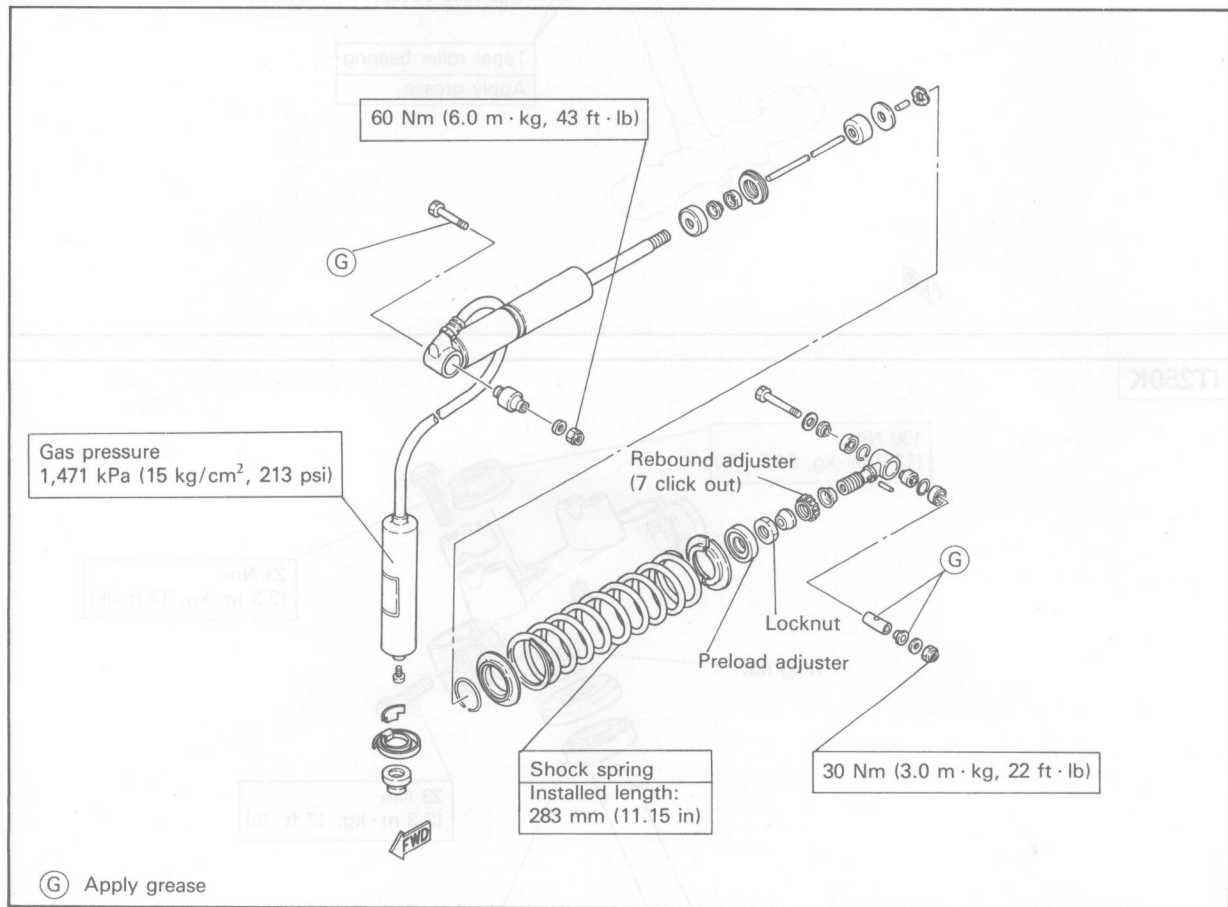

Rear shock setting

For details of rear shock setting, refer to the Race Preparation and Tuning Manuals.

It is advisable to take a note of the standard setting and specified range of adjustment.

Spring preload (Installed length)

Standard: 283 mm (11.14 in)
 Minimum: 265 mm (10.43 in)
 Maximum: 295 mm (11.61 in)

CAUTION:

Never attempt to turn the adjuster beyond the maximum or minimum setting.

The length of the spring (installed) changes 1 mm (0.04 in) per turn of the adjuster.

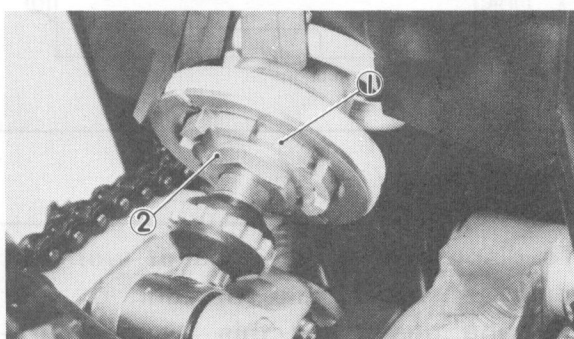

1. Adjuster 2. Locknut

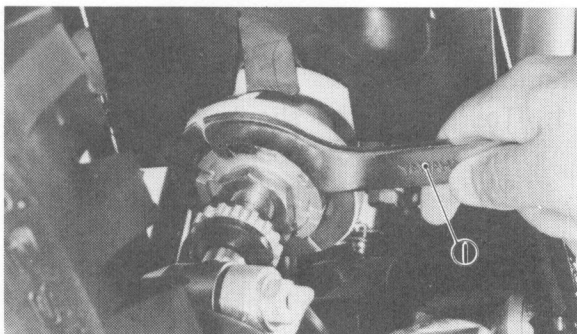

1. Special wrench

Tightening torque:
 55 Nm (5.5 m · kg, 40 ft · lb)

Shock spring

Type	Part Number	Spring rate (kg/mm)	I.D. Color
STD	26A-22212-00	k = 4.0	Green
LIGHT	26A-22212-10	k = 3.75	Pink
HEAVY	23X-22212-10	k = 4.25	White

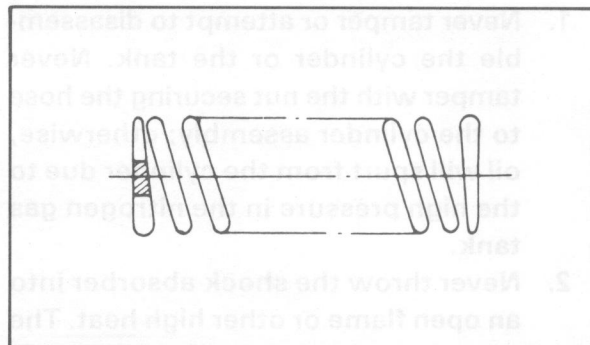

Rebound damping

STD SETTING: 7 clicks out

Don't turn out the adjuster more than 25 clicks from the stiffest position.

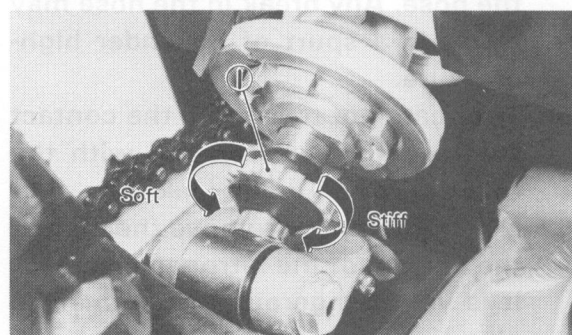

1. Rebound damping adjuster

Nitrogen gas

STD 1,471 kPa (15 kg/cm², 213 psi)
 MIN. 1,177 kPa (12 kg/cm², 171 psi)
 MAX. 1,765 kPa (18 kg/cm², 256 psi)

Handling notes

WARNING:

This shock absorber is provided with a separate type tank filled with high-pressure nitrogen gas. To prevent the danger of explosion, read and understand the following information before handling the shock absorber.

The manufacturer can not be held responsible for property damage or personal injury that may result from improper handling.

1. Never tamper or attempt to disassemble the cylinder or the tank. Never tamper with the nut securing the hose to the cylinder assembly; otherwise, oil will spurt from the cylinder due to the high pressure in the nitrogen gas tank.
2. Never throw the shock absorber into an open flame or other high heat. The shock absorber may explode as a result of nitrogen gas expansion and/or damage to the hose.
3. Be careful not to damage any part of the gas tank. A damaged gas tank will impair the damping performance or cause a malfunction.
4. Use care not to damage any part of the hose. Any break in the hose may result in a spurt of oil under high-pressure.
5. Take care not to scratch the contact surface of the piston rod with the cylinder; or oil could leak out.
6. Never attempt to remove the plug at the bottom of the nitrogen gas tank. It is very dangerous to remove the plug.
7. When scrapping the shock absorber, follow the instructions on disposal.
8. Don't use on this machine any suspension whose free length exceeds 480 mm (18.90 in). Such unit causes malfunctioning suspension.

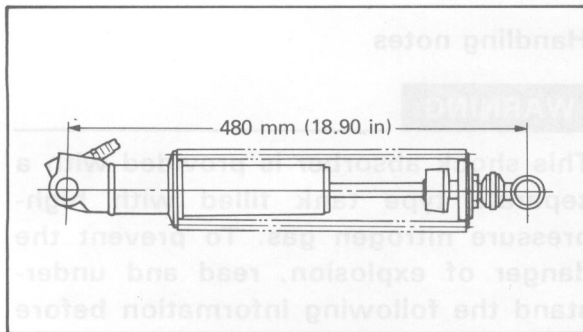

Notes on disposal (Yamaha dealers only)

Before disposing the shock absorber, be sure to extract the nitrogen gas. To do so, drill a 2 or 3 mm (0.08 ~ 0.12 in) hole through the tank at a position 25 ~ 30 mm (1.0 ~ 1.2 in) from the bottom end of the tank. At this time, wear eye protection to prevent eye damage from escaping gas and/or metal chips.

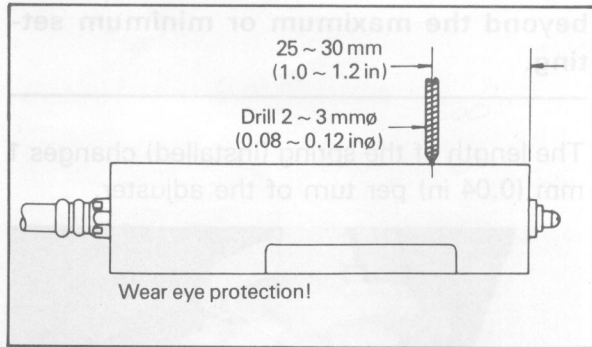

WARNING:

To dispose of a damaged or worn-out shock absorber, take the unit to your Yamaha dealer for this disposal procedure.

Removal

1. To remove the shock absorber, place the machine on a suitable stand to keep the bike stable while the shock absorber is removed.
2. Carefully remove the shock absorber from the frame; take care to avoid damaging the rubber hose or the shock reservoir.

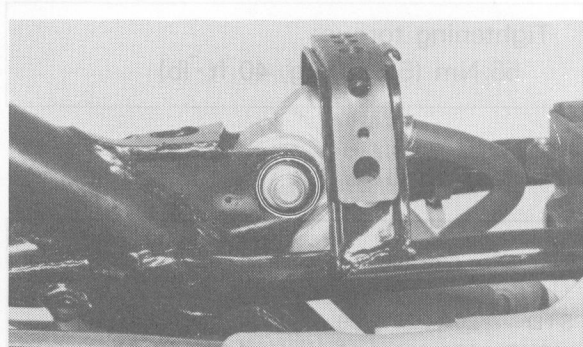

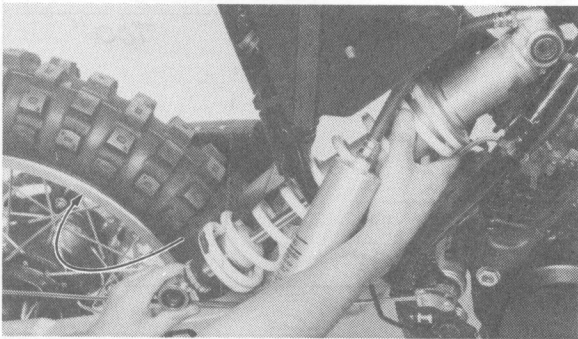
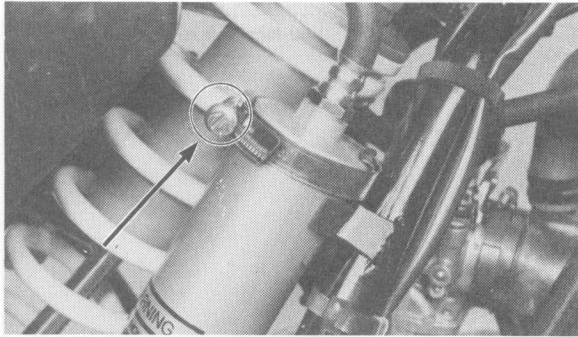
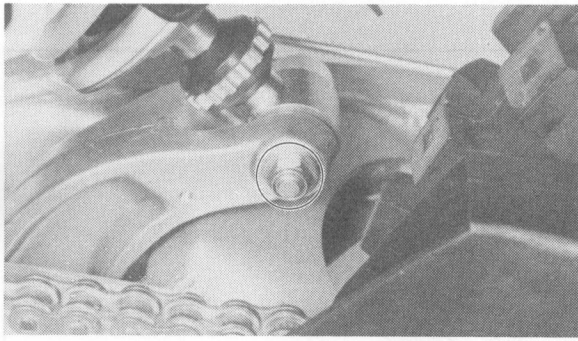

3. For assembly, reverse the procedure for disassembly while taking the following precautions:
 - a. Make sure the thrust covers and washers are positioned as illustrated.
 - b. The following areas must be lubricated during setup, use a high-quality, lithium-base grease.
 1. Swingarm pivot
 2. Lower rod pivot
 3. Upper rod pivot
 4. Arm pivot
 5. Lower shock mounting pivot
 6. Both brake torque arm pivots
 7. Brake backing plate bushing
 8. Wheel axle

LUBRICATE THESE AREAS.

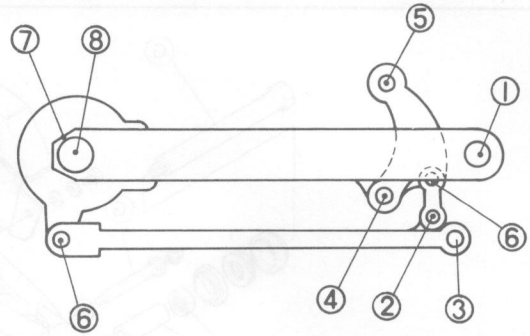

CAUTION:

Wipe off any excess grease, and avoid getting grease on the brake shoes.

- c. Tighten the nut to specification.
- d. Always use a new cotter pin.

Upper bolt (frame):

60 Nm (6.0 m · kg, 43 ft · lb)

Lower bolt (arm):

35 Nm (3.5 m · kg, 25 ft · lb)

SWINGARM

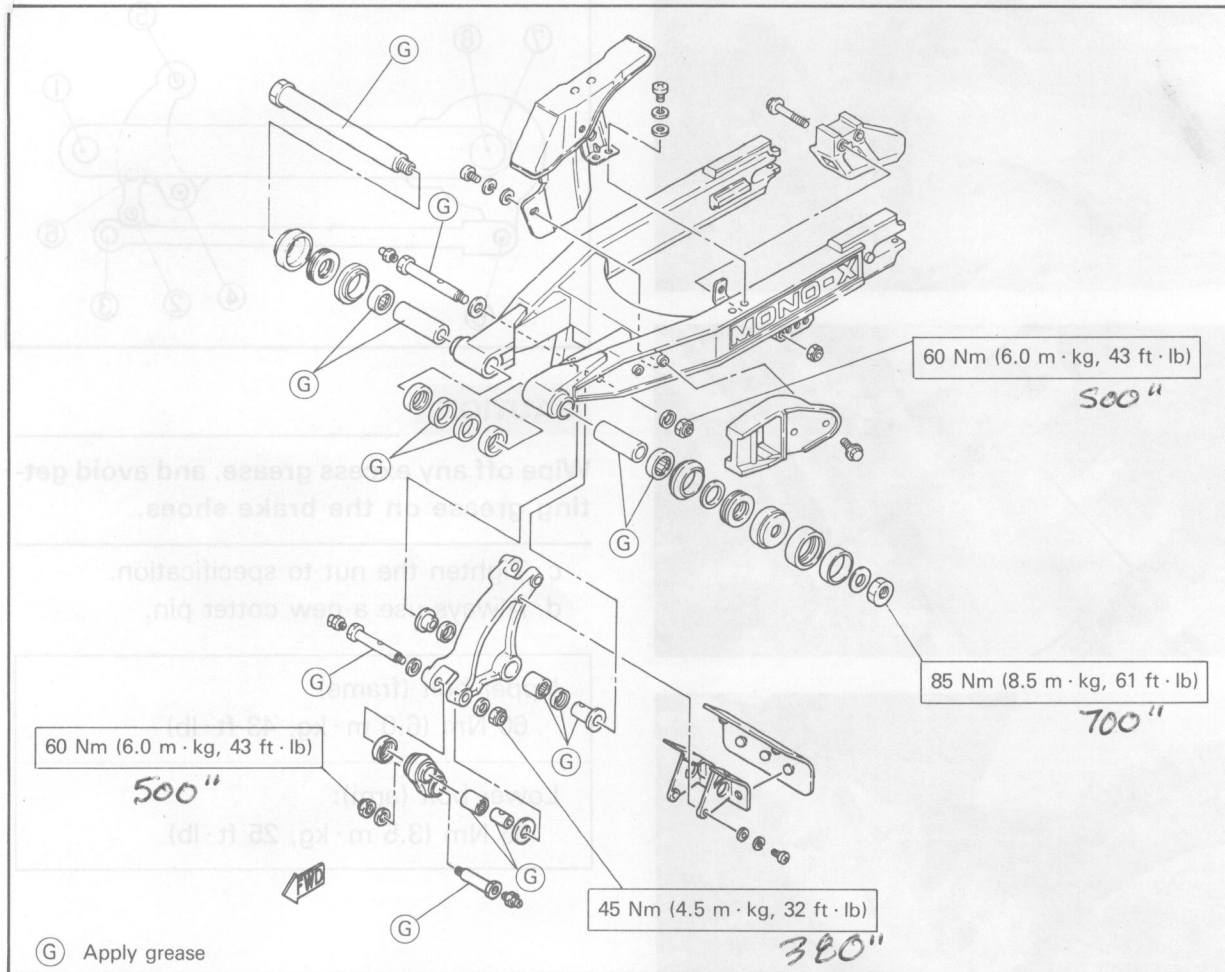

Inspection

1. To check the swingarm bearings, remove the rear wheel. Disconnect the shock from the swingarm.
2. Grasp the ends of the swingarm and try to move the arm sideways; if the free play exceeds tolerance, remove the swingarm and take it to your Yamaha dealer for bearing replacement.

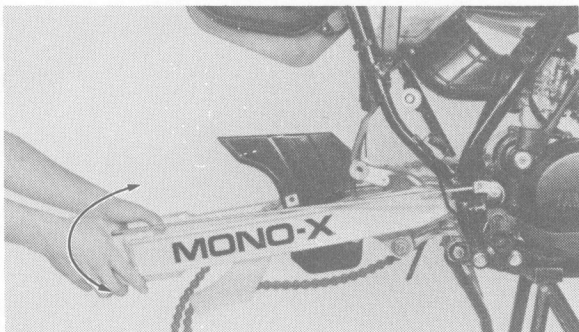

Swingarm free play:

0 ~ 1 mm (0 ~ 0.04 in)

3. Closely inspect the swingarm for cracks or other damage, and repair or replace it as required.
4. When reinstalling the swingarm, be sure to grease the bearings, bushings, and oil seal lips.
5. Grease the pivot shaft, install it and its nut, and torque the nut to specification.

Pivot shaft nut torque:

85 Nm (8.5 m · kg, 60 ft · lb)

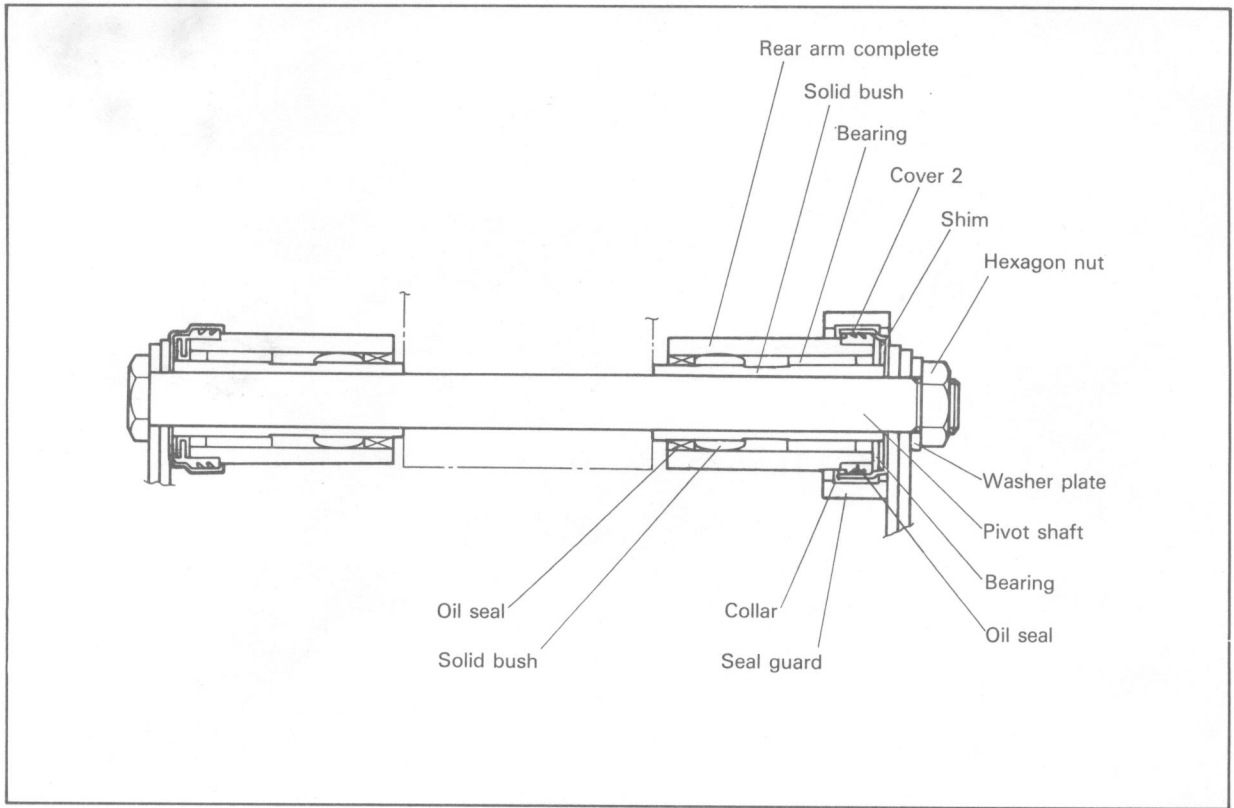

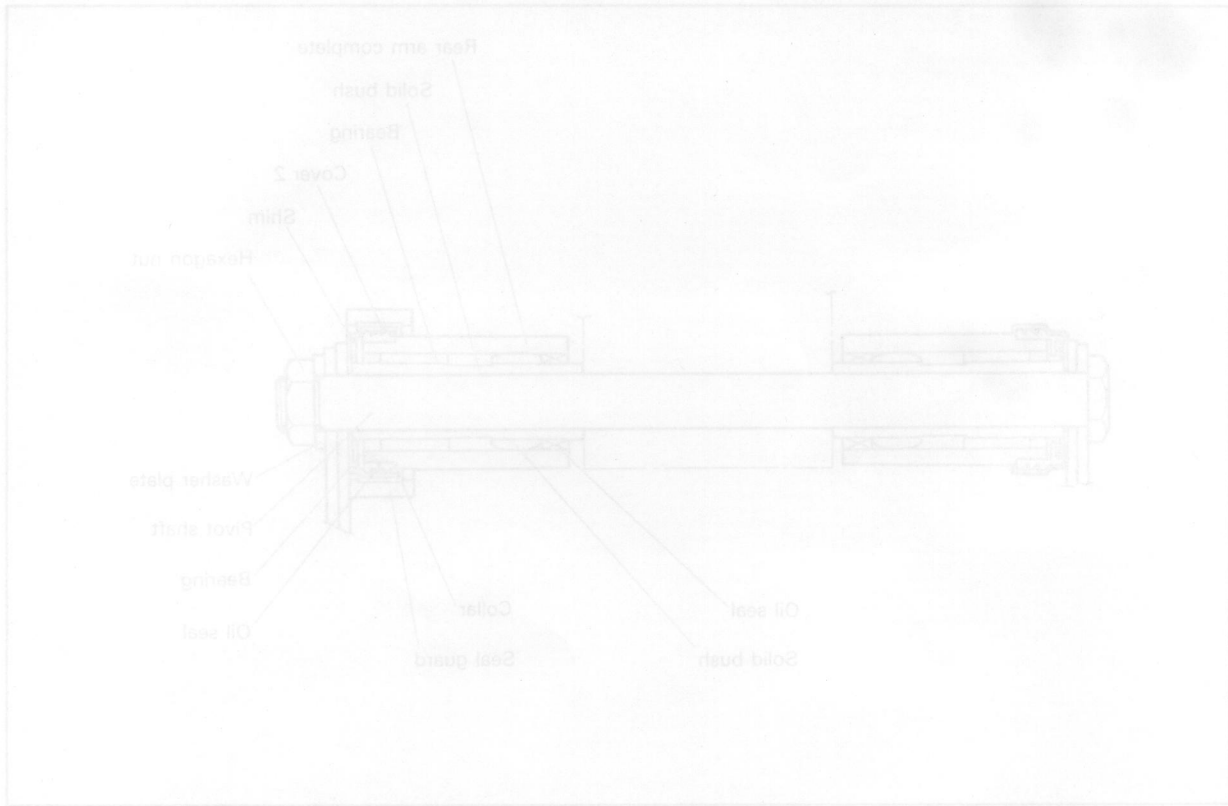

5 ELECTRICAL TROUBLESHOOTING

IGNITION SYSTEM 5-1

LIGHTING SYSTEM 5-4

WIRING DIAGRAM 5-7

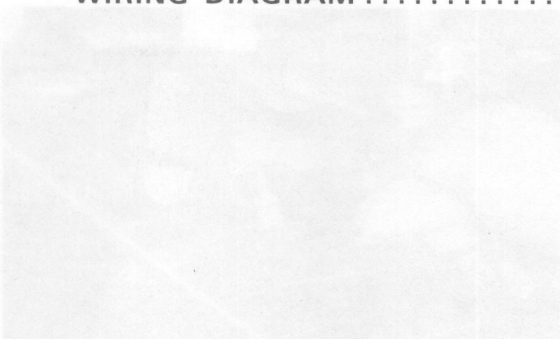

Hold the high tension lead 5 mm (0.20 in) from the head, and kick the engine through.



3. Engine stop switch

Disconnect the Black/White lead of engine stop switch at C.D.I. unit.

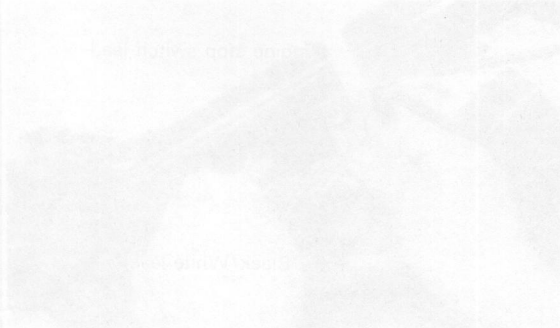

IGNITION SYSTEM 5-1

Make the wire harness in a position it will not make contact with exhaust pipe. which is short out C.D.I. unit.

5-4

5-7

Troubleshooting

If the ignition spark is of poor quality or if there is no spark at all, use the following procedure, to locate and repair the problem.

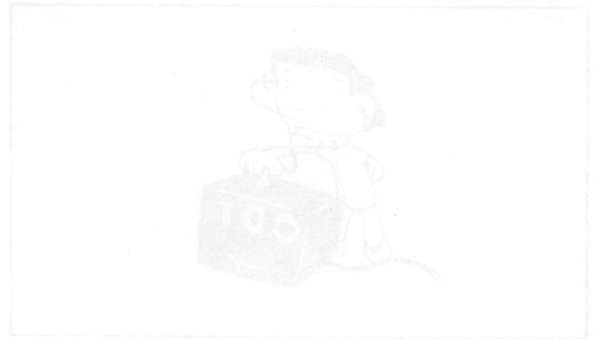

1. Spark plug test

Remove the spark plug and check the spark.



Ground the spark plug to the cylinder head, and kick the starter.

NOTE

If the spark plug is oily or has carbon deposits, clean it or replace.



5 ELECTRICAL TROUBLESHOOTING

IGNITION SYSTEM

Make sure the wire harness is in a position it will not make contact with exhaust pipe, which could short out C.D.I. unit.

Troubleshooting

If the ignition spark is of poor quality or if there is no spark at all, use the following procedure, to locate and repair the problem.



1	Spark plug test
Remove the spark plug and check the spark.	
Ground the spark plug to the cylinder head, and kick the starter.	

NOTE:
If the spark plug is oily or has carbon deposits, clean it or replace.

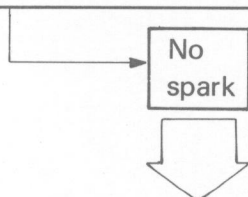

2	Spark gap test
Remove the spark plug cap and check the spark.	
Hold the high tension lead 5 mm (0.20 in) from the head, and kick the engine through.	

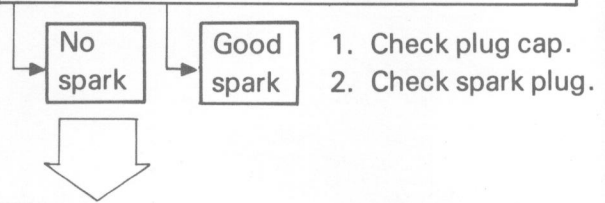

3	Engine stop switch
Disconnect the Black/White lead of engine stop switch at C.D.I. unit.	

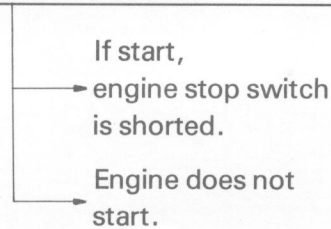

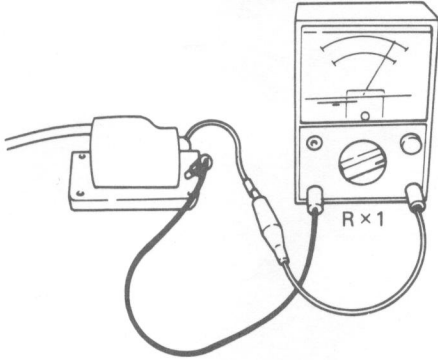
4	Ignition coil test
<p>Use the pocket tester to check the resistance of primary and secondary windings of the ignition coil.</p>	
	
<p>Primary coil resistance: $10\Omega \pm 15\%$</p>	

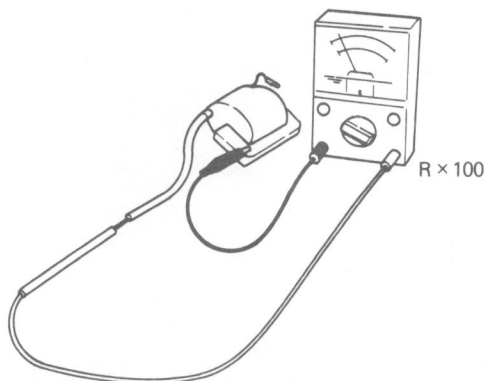
	
<p>Secondary coil resistance: $5.9\text{ K}\Omega \pm 15\%$</p>	

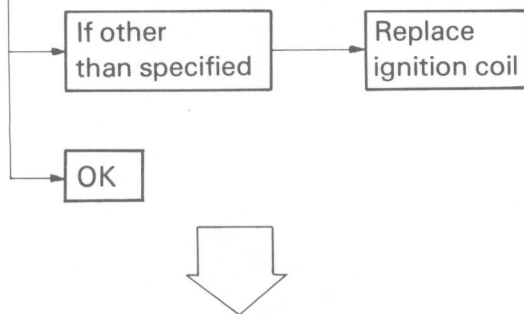

5	Connectors check-up
<ol style="list-style-type: none"> 1. Check the connectors and couplers for looseness of joining ends. 2. Keep the connectors and couplers from dirt or rust. 3. Check the engine stop switch and ground lead. 	

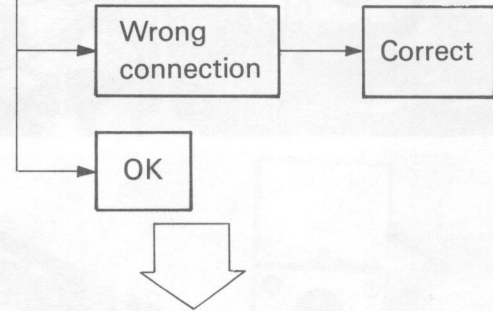

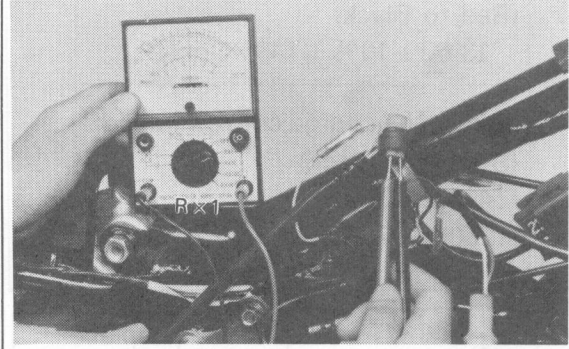
6	C.D.I. Magneto (Pickup coil) test
<p>Disconnect the magneto leads, and use the pocket tester to check the resistance of the pick-up coil.</p>	
	
<p>Pick-up coil resistance: (White/Red to Black) IT490K: $12.4\Omega \pm 10\%$ IT250K: $10\Omega \pm 10\%$</p>	

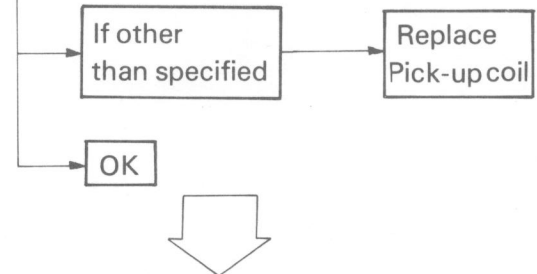

7

C.D.I. Magneto (Charge coil) test

Disconnect the magneto leads, and use the pocket tester to check the resistance of the magneto coils.

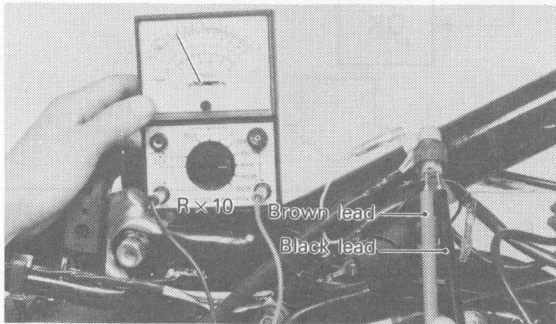
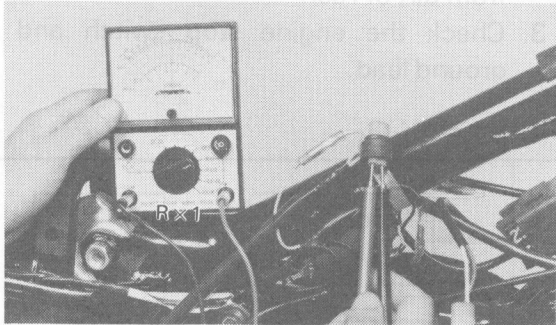

High-speed charge coil resistance:
(Red to Black)
 $13.6\Omega \pm 10\%$ (IT490K only)

Low-speed charge coil resistance:
(Brown to Black)
IT490K: $420\Omega \pm 10\%$
IT250K: $370\Omega \pm 10\%$

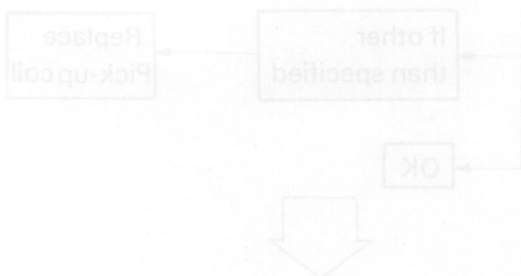
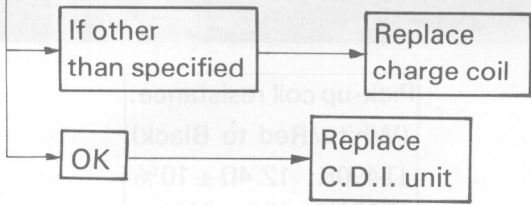

Ignition coil test

4

Use the pocket tester to check the resistance of primary and secondary windings of the ignition coil.

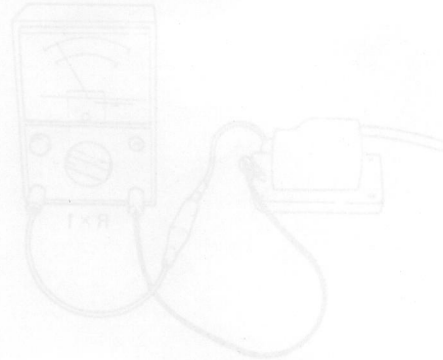

Primary coil resistance:
 $100 \pm 15\%$



Secondary coil resistance:
 $5.9K\Omega \pm 15\%$



LIGHTING SYSTEM

Headlight adjustment

1. Adjust the headlight beam by tightening or loosening the adjust screw.

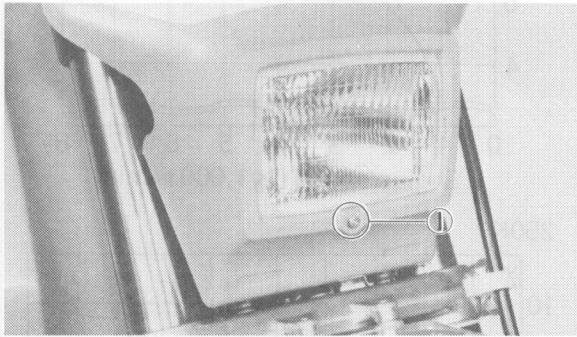

1. Adjusting screw
 - a. To direct the headlight beam upward, tighten the adjust screw.
 - b. To direct downward, loosen the screw.

Switching headlight terminals

The headlight has two filaments. Should the headlight burn out during operation, switch the headlight terminal to the other.

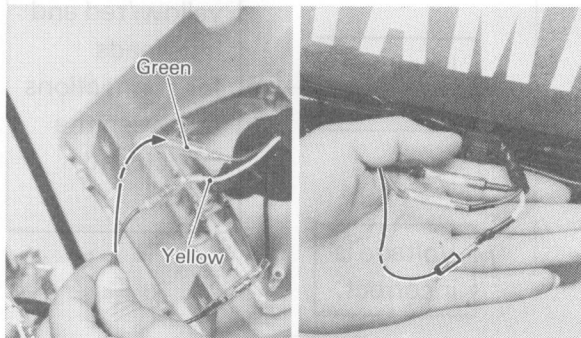

Bulb replacement

1. Remove the headlight assembly from the frame.
2. Turn the bulb holder counterclockwise and remove the defective bulb.

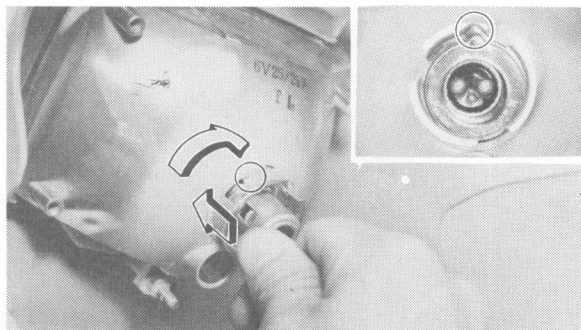

3. Install the taillight with the "UP" mark facing upward.

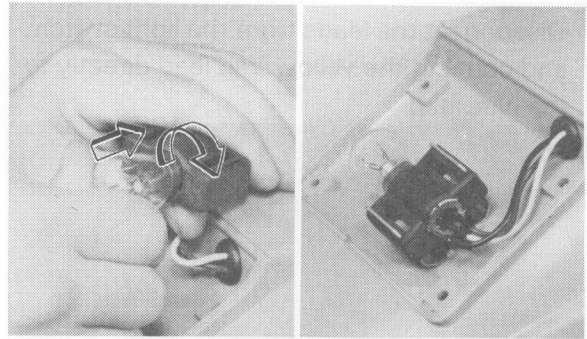

Troubleshooting

If the headlight or taillight will not come on, make checkups in the following sequence to determine the cause of trouble, and repair or replace the light (bulb).

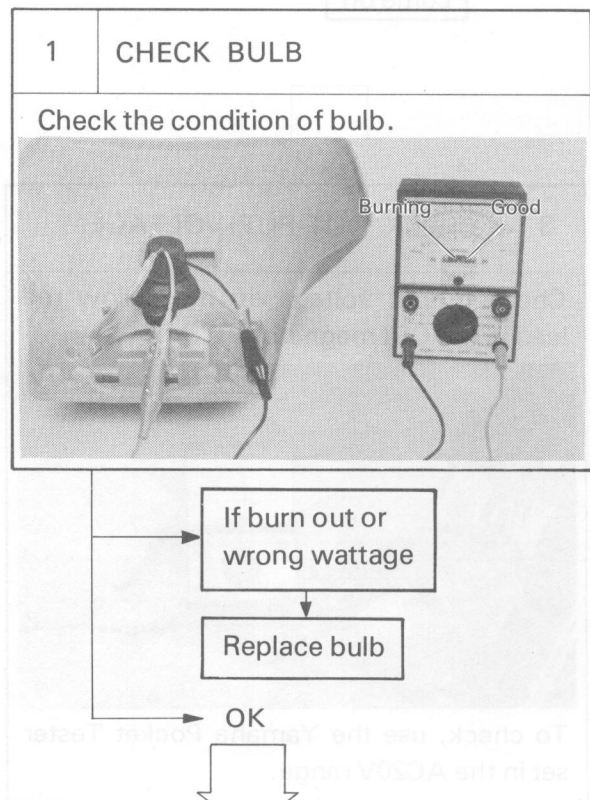

Engine speed	1T40K	1T40K	1T40K
3,000 rpm	3.0V or less	3.0V or less	3.0V or less
2,500 rpm	3.0V or less	3.0V or less	3.0V or less
2,000 rpm	3.0V or less	3.0V or less	3.0V or less
1,500 rpm	3.0V or less	3.0V or less	3.0V or less
1,000 rpm	3.0V or less	3.0V or less	3.0V or less
500 rpm	3.0V or less	3.0V or less	3.0V or less

2 CHECK SWITCH

Disconnect the leads from the light switch, and connect the yellow/red lead directly to the blue lead.

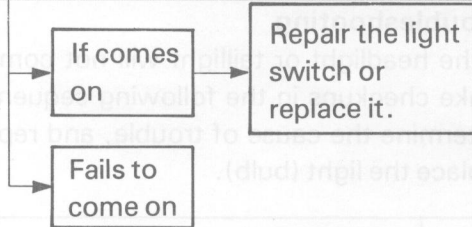
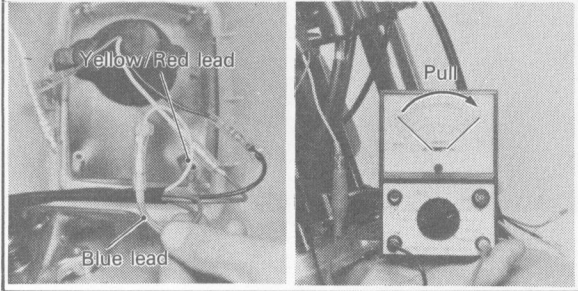

3 CHECK OUT-PUT VOLTAGE

Check output voltage on the yellow/red lead in the CDI magneto.

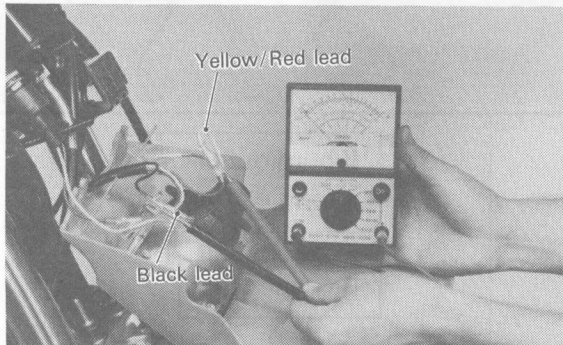

To check, use the Yamaha Pocket Tester set in the AC20V range.

Engine speed	Voltage	
	IT490K	IT250K
2,500 r/min	5.0V or more	6.4V or more
8,000 r/min	7.0V or less	9.0V or less

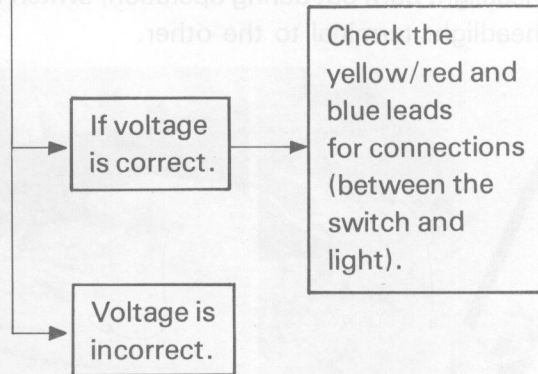
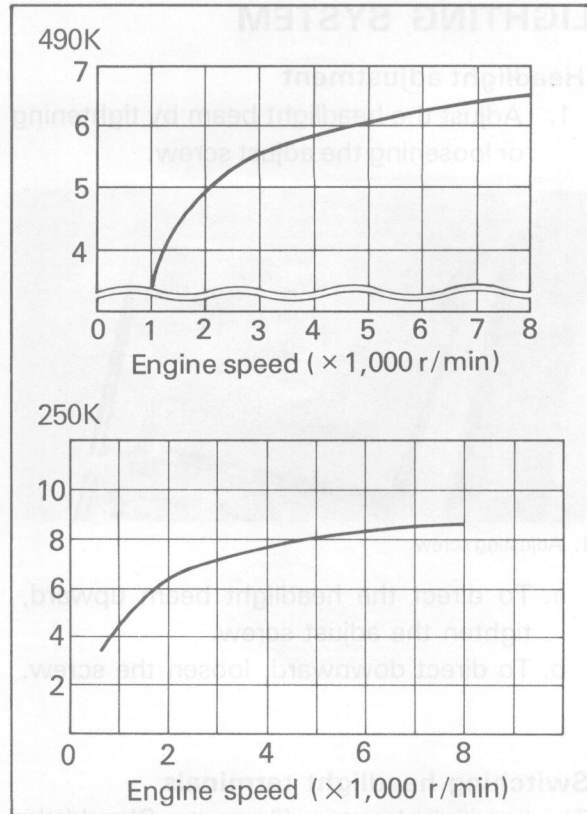

4 CHECK LIGHTING COIL

Check the lighting coil resistance.

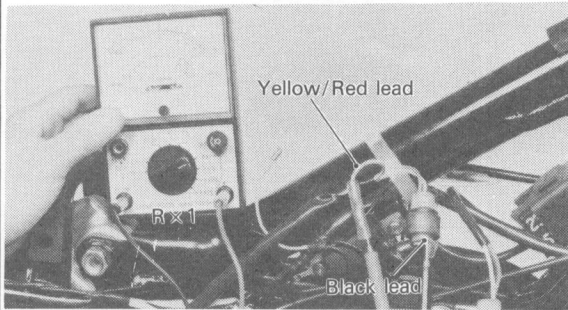

Lighting coil resistance:
 $0.48\Omega \pm 10\%$
(Yellow/Red to Black)

If other than specified

Replace lighting coil

If correct,
a. Check connector terminals for loose connection or corrosion.
b. Check the connection of ground lead.

WIRING DIAGRAM

IT490K

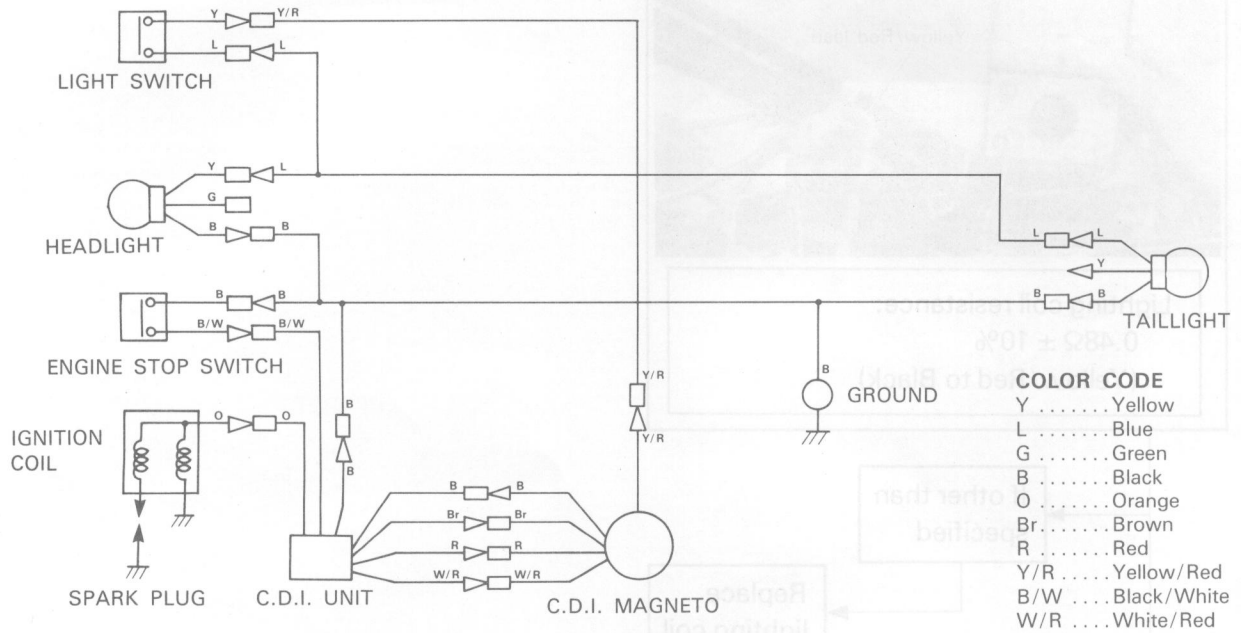

IT250K

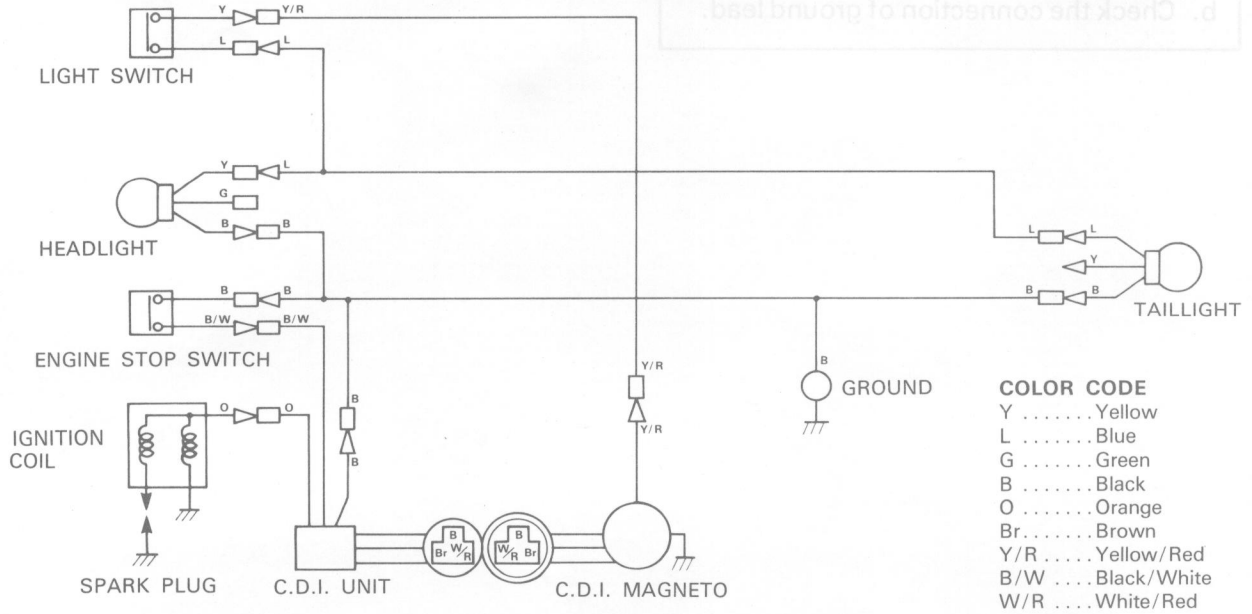

6 APPENDICES

TROUBLESHOOTING GUIDE

Engine is hard to start or does not start.

Ignition System	
Possible Cause	Remedy
<ol style="list-style-type: none"> 1. Spark plug is wet. 2. Ignition coil is faulty. 3. C.D.I. unit is faulty. 4. C.D.I. magneto is faulty (Pulser coil, source coil) 5. Ignition timing is incorrect. 6. Wire is broken, shorted or disconnected. 7. Engine stop switch is shorted. 	<ul style="list-style-type: none"> • Clean or replace • Replace • Replace • Replace • Adjust • Repair, replace or connect • Repair or replace
Compression System	
Possible Cause	Remedy
<ol style="list-style-type: none"> 1. Piston rings are sticking or worn. 2. Cylinder or piston is worn or scratched. 3. Compression leaks passing cylinder head gasket. (Head is distorted.) 4. Crankshaft side oil seal is faulty. 5. Air leaks through crankcase sealing surfaces. 	<ul style="list-style-type: none"> • Replace • Repair or replace • Replace (or repair) • Replace • Repair
Air/Fuel System	
Possible Cause	Remedy
<ol style="list-style-type: none"> 1. Carburetor pilot jet is clogged. 2. Fuel petcock or pipe is clogged. 3. Float valve is faulty. (Float height is too high or too low.) 4. Reed valve is broken or deformed. 5. Fuel tank filler cap or carburetor breather pipe is clogged. 6. Air screw is improperly adjusted. 7. Fuel is deteriorated. 8. Oil-gas mixing ratio is incorrect. 9. Air leaks through carburetor joints. 	<ul style="list-style-type: none"> • Clean • Clean • Replace (remove gasoline from crankcase) • Replace • Clean • Adjust • Replace • Replace • Retighten or replace gasket

Poor high speed performance

Ignition System	
Possible Cause	Remedy
<ol style="list-style-type: none"> 1. Spark plug is dirty or plug gap is too narrow. 2. C.D.I. unit is faulty. 3. C.D.I. magneto is faulty. 4. Ignition coil is faulty. 5. Ignition timing is incorrect. 6. Loose wire connection. 	<ul style="list-style-type: none"> • Clean, repair or replace • Replace • Replace • Replace • Adjust • Repair
Compression System	
Possible Cause	Remedy
<ol style="list-style-type: none"> 1. Piston rings are sticking or worn. 2. Cylinder or piston is worn or scratched. 3. Compression leakage through crankcase sealing surfaces or crankshaft side oil seal. 4. Carbon deposits in combustion chamber (Piston, Cylinder head). 	<ul style="list-style-type: none"> • Replace • Repair or replace • Repair or replace • Decarbonize
Air/Fuel System	
Possible Cause	Remedy
<ol style="list-style-type: none"> 1. Clogged carburetor jets. 2. Improperly adjusted main jet (High speed) 3. Improperly adjusted jet needle (Medium speed) 4. Incorrect fuel lever 5. Dirty or clogged air cleaner element 6. Clogged fuel tank filler cap or carburetor breather pipe. 7. Clogged fuel petcock or kinked fuel pipe. 8. Deteriorated fuel. 9. Improper oil-gas mixing ratio 10. Cracked or broken exhaust pipe (Leakage of exhaust gases). 	<ul style="list-style-type: none"> • Clean • Adjust • Adjust • Adjust • Clean • Clean • Clean or repair • Replace • Replace • Replace

Overheat

Possible Cause	Remedy
<ol style="list-style-type: none"> 1. Incorrect air-fuel mixture 2. Air leaks through carburetor joint. 3. Incorrect ignition timing 4. Carbon builds up in cylinder head or on piston head. 5. Improper spark plug heat range (too hot) 6. Fuel is deteriorated or oil-gas mixing ratio is incorrect. 	<ul style="list-style-type: none"> • Adjust • Repair or replace • Adjust • Decarbonize • Replace • Replace

Transmission and shifter

Trouble	Possible Cause	Remedy
Gears slip off	<ol style="list-style-type: none"> 1. Gear dogs are worn. 2. Shift forks are bent. (burnt or worn) 3. Shift cam stopper spring is fatigued. 	<ul style="list-style-type: none"> • Replace • Replace • Replace
Gear shifts skipping over the next.	<ol style="list-style-type: none"> 1. Shift cam stopper spring is fatigued. 2. Shift forks are bent. (burnt or worn) 	<ul style="list-style-type: none"> • Replace • Replace
Gear does not select	<ol style="list-style-type: none"> 1. Shift cam is worn. (broken) 2. Change shaft is bent. 3. Shift arm spring is broken. 4. Gears are broken. 	<ul style="list-style-type: none"> • Replace • Replace • Replace • Removal (Replace)
Shift pedal does not return.	<ol style="list-style-type: none"> 1. Change return spring is broken. 2. Change shaft is bent. 	<ul style="list-style-type: none"> • Replace • Replace

Clutch

Trouble	Possible Cause	Remedy
Clutch slips	<ol style="list-style-type: none"> 1. Friction plate is worn. 2. Clutch plate is worn. 3. Clutch spring is fatigued. 4. Pressure plate is deformed. 5. Clutch plug is too small. 6. Clutch adjustment is incorrect. 7. Match marks of clutch boss and pressure plate does not aligned. 	<ul style="list-style-type: none"> • Replace • Replace • Replace • Replace • Adjust • Adjust • Reassemble
Clutch drags	<ol style="list-style-type: none"> 1. Clutch plate is warped. 2. Clutch lock nut is loosen. 3. Friction plate is broken. 4. Clutch play is too much. 5. Oil viscosity is incorrect. 	<ul style="list-style-type: none"> • Replace • Replace • Replace • Adjust • Replace

Chassis

Steering head is loose		
Possible Cause	Remedy	
<ol style="list-style-type: none"> 1. Roller is worn. 2. Steering lock nut is loose. 	<ul style="list-style-type: none"> • Replace • Retighten 	
Wheels have excessive run-out		
Possible Cause	Remedy	
<ol style="list-style-type: none"> 1. Bearing is worn. 2. Rim has dent. 3. Spokes are loose (or broken). 4. Axle nut is loose. 	<ul style="list-style-type: none"> • Replace • Repair or replace • Retighten or replace • Retighten 	
Brakes		
Trouble	Possible Cause	Remedy
Faulty	<ol style="list-style-type: none"> 1. Brake shoes are worn. 2. Brake is improperly adjusted. 3. Brake drum contains water. 4. Lining is greasy. 	<ul style="list-style-type: none"> • Replace • Adjust • Clean • Degrease or replace
Not return smoothly	<ol style="list-style-type: none"> 1. Wire is starved for oil. 2. Camshaft is starved for grease. 3. Return spring or brake shoe spring is broken. 4. Brake pedal axle is starved for grease. 	<ul style="list-style-type: none"> • Grease or replace • Grease • Replace • Grease
Frame and Swing Arm		
Possible Cause	Remedy	
<ol style="list-style-type: none"> 1. Frame is cracked. 2. Rear arm is bend. 3. Rear arm is cracked. 4. Bushing is worn. 	<ul style="list-style-type: none"> • Weld, reinforce or replace • Repair or replace • Replace • Replace 	

Headlight/Taillight

Trouble	Possible Cause	Remedy
Faulty	<ol style="list-style-type: none"> 1. Burn out bulb. 2. Wire is broken, shorted or disconnected. 3. Lighting coil is faulty. 4. Lighting switch is faulty. 	<ul style="list-style-type: none"> • Replace • Repair or replace • Replace • Replace

SPECIFICATIONS



I. GENERAL SPECIFICATIONS

Item	Model	IT490K	IT250K
Model Code Number		26A	25Y
Frame Starting Number		26A-000101	25Y-000101
Engine Starting Number		26A-000101	25Y-000101
Dimensions:			
Overall Length		2,190 mm (86.2 in)	←
Overall Width		870 mm (34.3 in)	←
Overall Height		1,300 mm (51.2 in)	←
Seat Height		945 mm (37.2 in)	←
Wheelbase		1,485 mm (58.5 in)	←
Minimum Ground Clearance		340 mm (13.4 in)	←
Basic Weight (With Oil and Fuel)		119 kg (262.4 lb)	115 kg (253.6 lb)
Engine:			
Engine Type		Air-cooled 2-stroke, gasoline, torque induction	←
Cylinder Arrangement		Single cylinder, forward inclined	←
Displacement		487 cm ³	246 cm ³
Bore × Stroke		87 × 82 mm (3.43 × 3.23 in)	68 × 68 mm (2.68 × 2.68 in)
Compression Ratio		6.7 : 1	7.7 : 1
Starting System		Kick starter	←
Lubrication System		Premix (24 : 1) (Yamalube R) Premix (20 : 1) (Castrol R30) (Castrol A545)	← ← ←
Oil Type or Grade:			
Transmission Oil		Yamalube 4-cycle oil or SAE 10W30 type SE motor oil or GL gear oil	←
Periodic Oil Change		0.75 L (0.66 Imp qt, 0.79 US qt)	←
Total Amount		0.80 L (0.70 Imp qt, 0.85 US qt)	←
Air Filter		Wet type element	←
Fuel:			
Type		Premix, premium gasoline	←
Tank Capacity		13.5 L (3.0 Imp gal, 3.6 US gal)	←
Carburetor:			
Type/Manufacturer		VM38SS/MIKUNI	VM36SS/MIKUNI
Spark Plug:			
Type/Manufacturer		N-3C/CHAMPION	N-86/CHAMPION
Gap		0.7 ~ 0.8 mm (0.028 ~ 0.031 in)	0.5 ~ 0.6 mm (0.020 ~ 0.024 in)
Clutch Type		Wet, multiple-disc	←

Item	Model	IT490K	IT250K
Transmission:			
Primary Reduction System		Gear	←
Primary Reduction Ratio		63/24 (2.625)	←
Secondary Reduction System		Chain drive	←
Secondary Reduction Ratio	Sprocket	44/14 (3.142)	48/13 (3.692)
Transmission Type		Constant mesh, 5-speed	Constant mesh, 6-speed
Operation		Left foot operation	←
Gear Ratio 1st		32/12 (2.666)	←
2nd		28/16 (1.750)	29/15 (1.933)
3rd		25/19 (1.315)	27/18 (1.500)
4th		22/22 (1.000)	24/20 (1.200)
5th		22/28 (0.785)	22/22 (1.000)
6th		—	20/24 (0.833)
Chassis:			
Frame Type		Double cradle	←
Caster Angle		28°	←
Trail		118 mm (4.65 in)	←
Tire:			
Type		With tube	←
Size (F)		3.00-21-4PR	←
Size (R)		150/80-18-4PR	140/80-18-4PR
Brake:			
Front Brake Type		Drum brake (two leading)	←
Operation		Right hand operation	←
Rear Brake Type		Drum brake (leading trailing)	←
Operation		Right foot operation	←
Suspension:			
Front Suspension		Telescopic fork (pneumo-mechanical)	←
Rear Suspension		Swingarm (Monocross suspension)	←
Shock Absorber:			
Front Shock Absorber		Air, coil spring, oil damper	←
Rear Shock Absorber		Gas, coil spring, oil damper	←
Wheel Travel:			
Front Wheel Travel		300 mm (11.8 in)	←
Rear Wheel Travel		300 mm (11.8 in)	←
Electrical:			
Ignition System		C.D.I. Magneto	←

II. MAINTENANCE SPECIFICATIONS

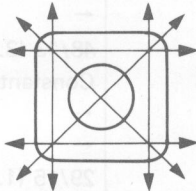
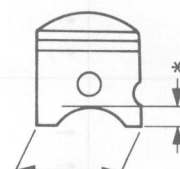
A. Engine

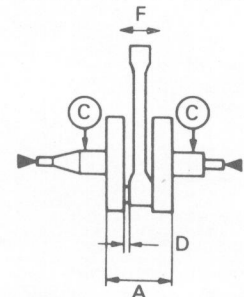
Item	Model	IT490K	IT250K
Cylinder Head: Warp Limit 		$<0.03 \text{ mm (0.0012 in)}$ *Lines indicate straightedge measurement.	← ←
Cylinder: Bore Size Taper Size Out of Round Limit		$87_{+0.02}^0 \text{ mm (3.43}_{+0.0008}^0 \text{ in)}$ $0.08 \text{ mm (0.003 in)}$ $0.05 \text{ mm (0.002 in)}$	$68_{+0.02}^0 \text{ mm (2.68}_{+0.0008}^0 \text{ in)}$ ← ←
Piston: Piston Size/Measuring Point* 		$87.00 \text{ mm (3.42 in) / 10 mm (0.4 in)}$	$68.00 \text{ mm (2.68 in)}$
Piston Clearance <Limit>		$0.070 \sim 0.075 \text{ mm (0.0028 \sim 0.0030 in)}$ $<0.1 \text{ mm (0.004 in)}>$	$0.045 \sim 0.050 \text{ mm (0.0018 \sim 0.0020 in)}$ ←
Oversize 1st 2nd 3rd 4th Piston Offset		$87.25 \text{ mm (3.435 in)}$ $87.50 \text{ mm (3.445 in)}$ $87.75 \text{ mm (3.456 in)}$ $88.00 \text{ mm (3.465 in)}$ $1.5 \text{ mm (0.06 in) / EX-side}$	$68.25 \text{ mm (2.687 in)}$ $68.50 \text{ mm (2.697 in)}$ $68.75 \text{ mm (2.707 in)}$ $69.00 \text{ mm (2.717 in)}$ ←
Piston Ring: Sectional Sketch Top Ring 		Keystone $B = 1.5 \text{ mm (0.06 in)}$ $T = 3.4 \text{ mm (0.13 in)}$	← $B = 1.2 \text{ mm (0.05 in)}$ $T = 2.8 \text{ mm (0.11 in)}$
2nd Ring End Gap (Installed) Top Ring 2nd Ring Side Clearance (Installed) Top Ring 2nd Ring		Keystone $B = 1.5 \text{ mm (0.06 in)}$ $T = 3.4 \text{ mm (0.13 in)}$ $0.35 \sim 0.50 \text{ mm (0.014 \sim 0.020 in)}$ $0.35 \sim 0.50 \text{ mm (0.014 \sim 0.020 in)}$ $0.02 \sim 0.06 \text{ mm (0.0008 \sim 0.0024 in)}$ $0.02 \sim 0.06 \text{ mm (0.0008 \sim 0.0024 in)}$	← ← ← ← ← ←
Crankshaft: 			

Item	Model	IT490K	IT250K
Crank Width "A"		66 ^{-0.05} mm (2.598 ^{-0.002} in)	62 ^{-0.05} mm (2.441 ^{-0.002} in)
Run Out Limit "C"		<0.03 mm (0.0012 in)>	←
Connecting Rod Big End Side Clearance "D"		0.25 ~ 0.75 mm (0.0098 ~ 0.0295 in)	←
Small End Free Play Limit "F"		<2 mm (0.08 in)>	←
Clutch:			
Friction Plate Thickness/ Quantity		3.0 mm (0.12 in)/7 pcs.	←
Wear Limit		<2.7 mm (0.11 in)>	←
Clutch Plate Thickness/ Quantity		1.6 mm (0.063 in)/6 pcs.	←
Warp Limit		<0.05 mm (0.002 in)>	←
Clutch Spring Free Length/Quantity		35.5 mm (1.40 in)/6 pcs	31.2 mm (1.23 in)/6 pcs
Clutch Spring Minimum Length		<34.5 mm (1.36 in)>	<30.2 mm (1.19 in)>
Clutch Housing Thrust Clearance		0.17 ~ 0.23 mm (0.0067 ~ 0.0090 in)	←
Push Rod Bending Limit		<0.2 mm (0.008 in)>	←
Kick Starter Type:		Kick and mesh type	←
Kick Clip Friction Type		P = 0.8 ~ 1.2 kg (1.76 ~ 2.65 lb)	←
			
Air Filter Oil Grade (Oiled Filter)		Foam-air-filter oil	←
* Carburetor:			
Type/Manufacturer		VM38SS/MIKUNI	VM36SS/MIKUNI
I.D. Mark		4V6-10	25Y-00
Main Jet (M.J.)		#390	#380
Jet Needle-Clip Position (J.N.)		6F39-4	6F34-4
Needle Jet (N.J.)		Q-2	N-8
Cutaway (C.A.)		2.0	2.0
Pilot Jet (P.J.)		#40	#40
Pilot Air Screw (P.A.S.)		1 and 3/8	1 and 1/4
Valve Seat Size (V.S.)		ø3.5	ø3.5
Starter Jet (G.S.)		80	80
Float Height (F.H.)		27 ± 1.0 mm (1.1 ± 0.04 in)	24 ± 1.0 mm (0.94 ± 0.04 in)
Reed Valve:			
Valve Stopper Height		12 ± 0.2 mm (0.47 ± 0.008 in)	←
Valve Bending Limit		0.6 mm (0.024 in)	←

II. MAINTENANCE SPECIFICATIONS

Chassis

Item	Model	IT490K	IT250K
Steering System:			
Steering Bearing Type		Taper roller bearing	←
Lock to Lock Angle		40°	←
Front Suspension:			
Front Fork Travel		300 mm (11.8 in)	←
Fork Spring Free Length		529 mm (20.8 in)	←
Collor Length		110 mm (4.3 in)	←
Spring Rate/ Stroke		K = 2.8 N/mm (0.290 kg/mm, 16.2 lb/in)	←
Optional Spring		Yes	
Spring Rate, Soft (1 slit)		K = 2.7 N/mm (0.275 kg/mm, 15.4 lb/in)	←
Hard (2 slits)		K = 3.0 N/mm (0.305 kg/mm, 17.1 lb/in)	←
Oil Capacity and Oil Level		578 cm ³ (20.4 Imp oz, 19.5 US oz)/ 170 mm (6.7 in) (From top of inner tube fully compressed without spring.)	←
Oil Grade		Fork oil 10 wt	←
Enclosed Air Pressure		0 kPa (0 kg/cm ² , 0 psi)	←
Rear Suspension:			
Shock Absorber Travel		117 mm (4.6 in)	←
Spring Free Length		300 mm (12 in)	←
Fitting Length		283 mm (11.1 in)	←
Spring Rate/ Stroke		K = 39.2 N/mm (4.0 kg/mm, 224 lb/in)	←
Optional Spring		Yes	←
Spring Rate, Soft (White)		K = 41.6 N/mm (4.25 kg/mm, 238 lb/in)	←
Soft (Green)			
Hard (Blue)		K = 46.6 N/mm (4.75 kg/mm, 266 lb/in)	←
Enclosed Gas Pressure		1,471 kPa (15 kg/cm ² , 213.3 psi)	←
Max. ~ Min.		1,177 ~ 1,765 kPa (12 ~ 18 kg/cm ² , 170.6 ~ 256.0 psi)	←
Rear Arm:			
Swingarm Free Play Limit			
End		<1 mm (0.04 in)>	←
Side		<0.2 mm (0.008 in)>	←
Wheel:			
Front Wheel Type		Spoke wheel	←
Rear Wheel Type		Spoke wheel	←
Front Rim Size/ Material		1.60-21/ Aluminum	←
Rear Rim Size/ Material		MT-2.50-18/ Aluminum	←
Rim Runout Limit			
Vertical		<2.0 mm (0.08 in)>	←
Lateral		<2.0 mm (0.08 in)>	←

Item	Model		IT490K			IT250K
Drive Chain:						
Type/Manufacturer			DK520VS			←
Number of Links			109 links + Joint			111 links + Joint
Chain Free Play			20 ~ 30 mm (0.8 ~ 1.2 in)			←
Drum Brake:						
Type	Front		Two-leading			←
	Rear		Leading and trailing			←
Drum Inside Dia						
<Limit>	Front		130 mm (5.12 in)			←
	Rear		<131 mm (5.16 in)>			←
			150 mm (5.91 in)			←
			<151 mm (5.94 in)>			←
Lining Thickness			4 mm (0.16 in)			←
<Limit>			<2 mm (0.08 in)>			←
Shoe Spring Free Length Front/ Rear			36.5 mm (1.44 in)/ 68.0 mm (2.68 in)			←
Brake Lever & Brake Pedal						
Brake Lever Free Play/ Position			5 ~ 8 mm (0.2 ~ 0.32 in) at lever pivot			←
Brake Pedal Position			10 mm (0.4 in)			←
Brake Pedal Free Play			20 ~ 30 mm (0.8 ~ 1.2 in) (Vertical height below footrest top)			←
Clutch Lever Free Play/ Position						
			2 ~ 3 mm (0.08 ~ 0.12 in)/ at lever pivot			←
Tightening Torque:						
	Thread Size	Q'ty	Nm	m · kg	ft · lb	Remarks
Front wheel axle	M14 × 1.5	1	60	6.0	43	
Handle crown -Inner tube	M 8 × 1.25	4	23	2.3	17	
-Steering shaft	M22 × 1.0	1	130	13.0	94	
-Handle holder	M 8 × 1.25	4	23	2.3	17	
Steering nut	M25 × 1.0	1	10	1.0	7.2	
Engine mount -Front, Frame	M 8 × 1.25	2	30	3.0	22	
-Front, Engine	M 8 × 1.25	1	30	3.0	22	
-Lower	M 8 × 1.25	1	30	3.0	22	
-Rear, Upper	M 8 × 1.25	2	30	3.0	22	
-Rear, Engine	M10 × 1.25	1	65	6.5	47	
Rear wheel axle	M18 × 1.5	1	100	10.0	72	
Sprocket wheel -Hub	M 8 × 1.25	6	30	3.0	22	
Rear shock -Frame	M10 × 1.25	1	60	6.0	43	
Pivot axle	M16 × 1.5	1	85	8.5	61	
Brake cam lever	M 6 × 1.0	1	10	1.0	7.2	
Relay arm -Swingarm	M12 × 1.25	1	60	6.0	43	
-Rear shock	M10 × 1.25	1	45	4.5	32	
-Connecting rod	M10 × 1.25	1	45	4.5	32	
Frame -Connecting rod	M10 × 1.25	1	60	6.0	43	
Footrest -Frame	M12 × 1.25	1	60	6.0	43	
	M10 × 1.25	1	60	6.0	43	

Electrical

Item	Model	IT490K	IT250K
Voltage:		6V	←
Ignition System: Ignition Timing (B.T.D.C.)		2,000 r/min B.T.D.C. 2.0 ± 0.1 mm (0.08 ± 0.004 in)	← B.T.D.C. 1.65 ± 0.1 mm (0.06 ± 0.004 in)
Advancer Type (IT490K)		Electrical	←
		(IT250K)	←
C.D.I.			
Magneto-Model/ Manufacturer		F3T201/MITSUBISHI	F3T206/MITSUBISHI
Pickup Coil Resistance (Color)		$12.4\Omega \pm 10\%$ at 20°C (68°F) (White/ Red — Black)	$10\Omega \pm 10\%$ at 20°C ←
Charging Coil Resistance (Color)		$420\Omega \pm 10\%$ at 20°C (68°F) (Brown — Black)	$370\Omega \pm 10\%$ ←
C.D.I. Unit-Model/ Manufacturer		F8T01172/MITSUBISHI	F8T07071/MITSUBISHI
Ignition Coil:			
— Model/ Manufacturer		F6T505/MITSUBISHI	←
Minimum Spark Gap		10 kV or more at 500 r/min 15 kV or less at 8,000 r/min 6 mm (0.24 in)	← ← ←
Primary Winding Resistance		$10\Omega \pm 15\%$ at 20°C (68°F)	←
Secondary Winding Resistance		$5.9\text{k}\Omega \pm 15\%$ at 20°C (68°F)	←
Lighting System:			
Headlight		6V, 25W/25W	←
Taillight		6V, 3W	←
Lighting Coil Resistance		$0.48\Omega \pm 10\%$ (Yellow/Red — Black)	←
Lighting voltage Min.		5V at 2,500 r/min	6.4V at 2,500 r/min
Max.		7V at 8,000 r/min	9.0V at 8,000 r/min
		(IT490K)	(IT250K)

A (NUT)	B (BOLT)	TORQUE SPECIFICATION		
		Nm	m · kg	ft · lb
10 mm	6 mm	5	0.6	4.3
12 mm	8 mm	15	1.5	11.0
14 mm	10 mm	30	3.0	22.0
17 mm	12 mm	55	5.5	40.0
19 mm	14 mm	85	8.5	61.0
22 mm	16 mm	130	13.0	94.0

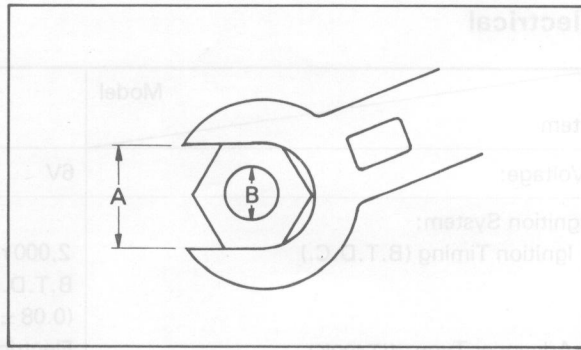

A: Distance across flats
B: Outside thread diameter

CONVERSION TABLES

METRIC TO INCH SYSTEM			
	KNOWN	MULTIPLIER	RESULT
TORQUE	m · kg	7.233	ft · lb
	m · kg	86.80	in · lb
	cm · kg	0.0723	ft · lb
	cm · kg	0.8680	in · lb
WT.	kg	2.205	lb
	g	0.03527	oz
FLOW/DISTANCE	km / ℓ	2.352	mpg
	km/hr	0.6214	mph
	km	0.6214	mi
	m	3.281	ft
	m	1.094	yd
	cm	0.3937	in
	mm	0.03937	in
VOL./CAPACITY	cc (cm ³)	0.03382	oz (US liq)
	cc (cm ³)	0.06102	cu.in
	ℓ (liter)	2.1134	pt (US liq)
	ℓ (liter)	1.057	qt (US liq)
	ℓ (liter)	0.2642	gal (US liq)
MISC.	kg/mm	56.007	lb/in
	kg/cm ²	14.2234	psi (lb/in ²)
	Centigrade(°C)	9/5(°C) + 32	Fahrenheit(°F)

INCH TO METRIC SYSTEM			
	KNOWN	MULTIPLIER	RESULT
TORQUE	ft · lb	0.13826	m · kg
	in · lb	0.01152	m · kg
	ft · lb	13.831	cm · kg
	in · lb	1.1521	cm · kg
WT.	lb	0.4535	kg
	oz	28.352	g
FLOW/DISTANCE	mpg	0.4252	km / ℓ
	mph	1.609	km/hr
	mi	1.609	km
	ft	0.3048	m
	yd	0.9141	m
	in	2.54	cm
	in	25.4	mm
VOL./CAPACITY	oz (US liq)	29.57	cc (cm ³)
	cu.in	16.387	cc (cm ³)
	pt (US liq)	0.4732	ℓ (liter)
	qt (US liq)	0.9461	ℓ (liter)
	gal (US liq)	3.785	ℓ (liter)
MISC.	lb/in	0.017855	kg/mm
	psi (lb/in ²)	0.07031	kg/cm ²
	Fahrenheit(°C)	5/9(°F - 32)	Centigrade(°F)

DEFINITION OF UNITS

Unit	Read	Definition	Measure
mm	millimeter	10 ⁻³ meter	Length
cm	centimeter	10 ⁻² meter	Length
kg	kilogram	10 ³ gram	Weight
N	Newton	1 kg × m/sec ²	Force
Nm	Newton meter	N × m	Torque
m · kg	Meter kilogram	m × kg	Torque
Pa	Paskal	N/m ²	Pressure
N/mm	Newton per millimeter	N/mm	Spring rate
L	Liter	—	Volume or Capacity
cm ³	Cubic centimeter	—	Volume or Capacity
r/min	Rotation per minute	—	Engine speed

CABLE ROUTING DIAGRAM

Front brake wire

Right lever → Behind the throttle wire → Wire guides (on the left side of handle crown → on the left side of under-bracket) → Through the hose clamp and tighten the clamp screw (on the left side of front fork boss) → cam shaft lever.

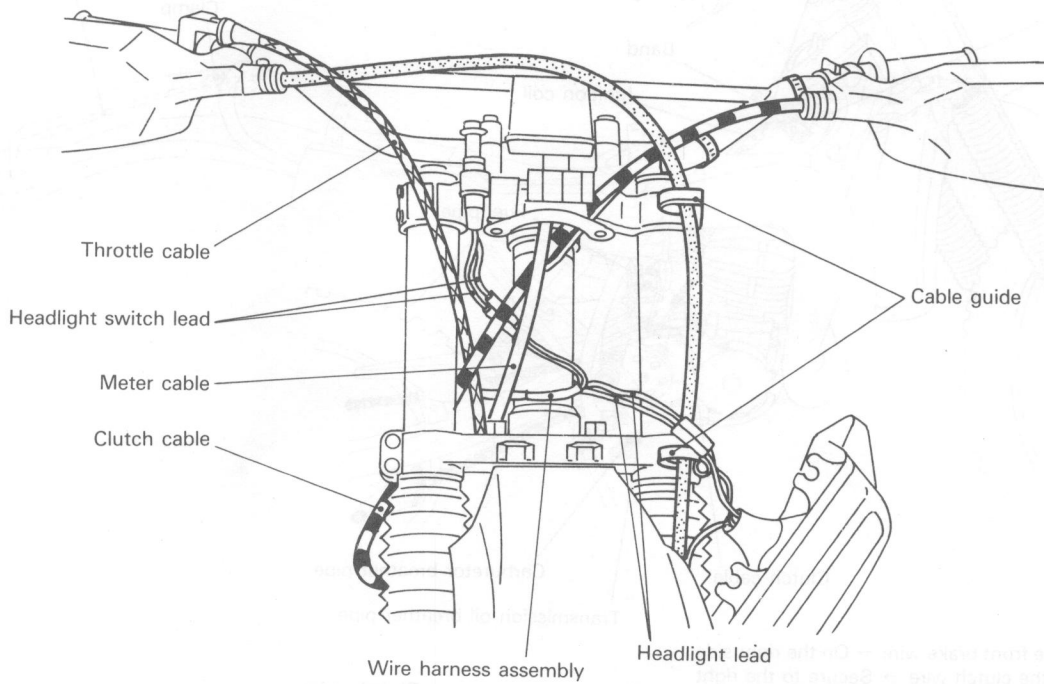

Use care so that the engine stop switch lead is not crushed by the holder.

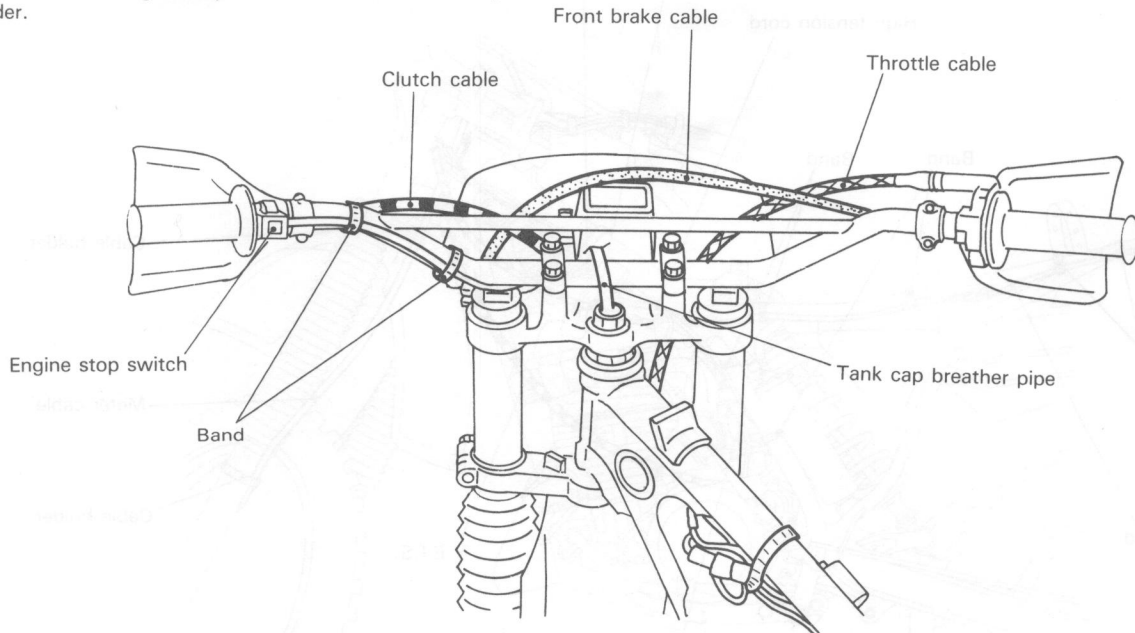

Engine stop switch lead

Secure to the handlebar with bands (at two places) → Route over the handle crown → Through the meter bracket → On the right side of head pipe (behind the clutch wire and meter cables) → Connect to the lead (coming from the CDI unit) on the right side of main pipe and secure to the main pipe with the band.

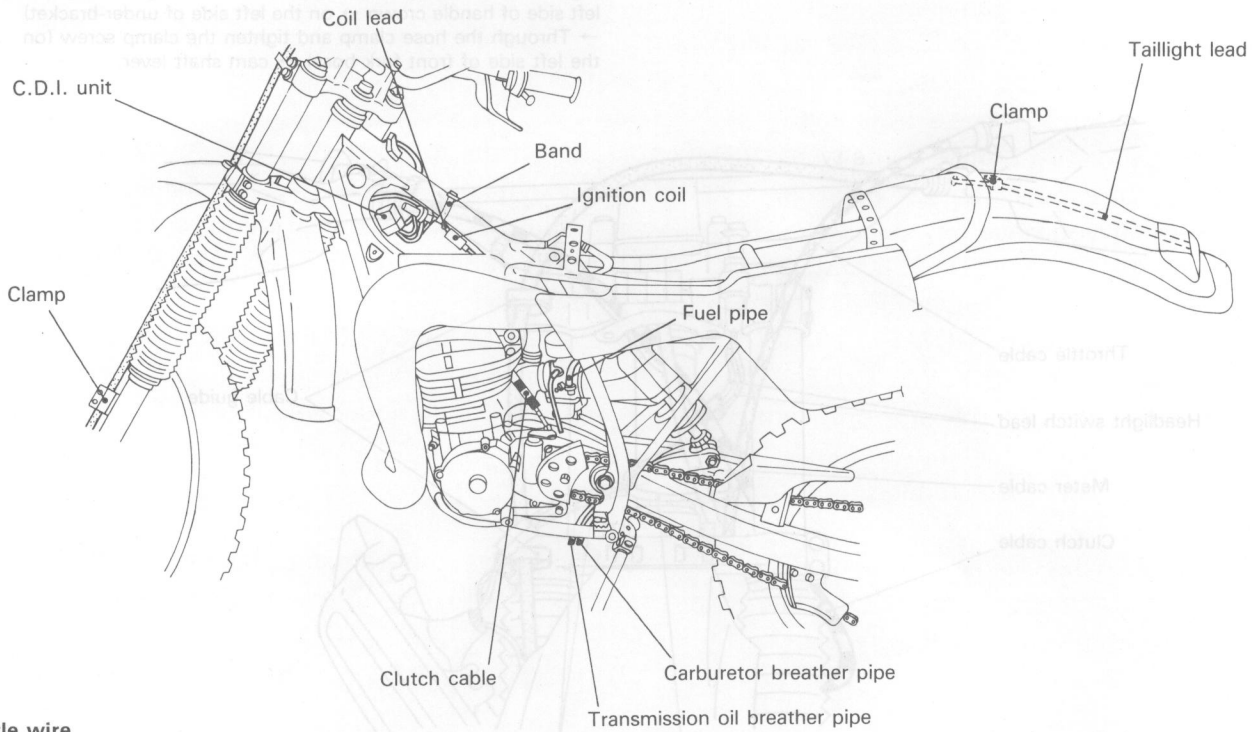

Throttle wire

Grip cap → In front of the front brake wire → On the right side of head pipe → Behind the clutch wire → Secure to the right rear part of muffler tension pipe stay with the band → On the left side of rear upper-bracket → Carburetor.

Clutch wire

Left lever → Behind the front brake wire → Meter bracket → On the right side of head pipe (on this side of throttle wire and on the other side of meter cable) → Clamp to the right side of engine (cylinder body) → Clutch lever axle.

