



IT175G: PERFORMANCE INFORMATION
RACE PREP INFORMATION

The Competition Support Department has come up with some very useful performance and race preparation information for the IT175G on this and the following pages.

By opening the air box and changing to a F silencer (which needs to be modified to fit) will allow the engine to have less restriction, both intake and exhaust, the result is: more torque, better throttle response with a two horse power increase.

Follow the procedures provided below:

1. SILENCER:

The following parts are needed:

<u>Qty.</u>	<u>Part Number</u>	<u>Description</u>
1	2W6-14753-00.....	silencer
1	1W2-14752-00.....	outlet, pipe
1	(use off G silencer.....	cap, silencer)
1	8mm.....	locknut
2	8mm X 35mm.....	bolt
2	8mm X 5mm thick.....	washer
1	23mm I.D. X 1mm thick X 100mm length.....	stinger

2. Mount F silencer on bike using rear mount on silencer (A) and rear mount on muffler stay bracket (B) place a 5mm thick spacer (C) between the silencer and muffler stay bracket (C). A longer 8mm X 35mm bolt will be necessary (D).

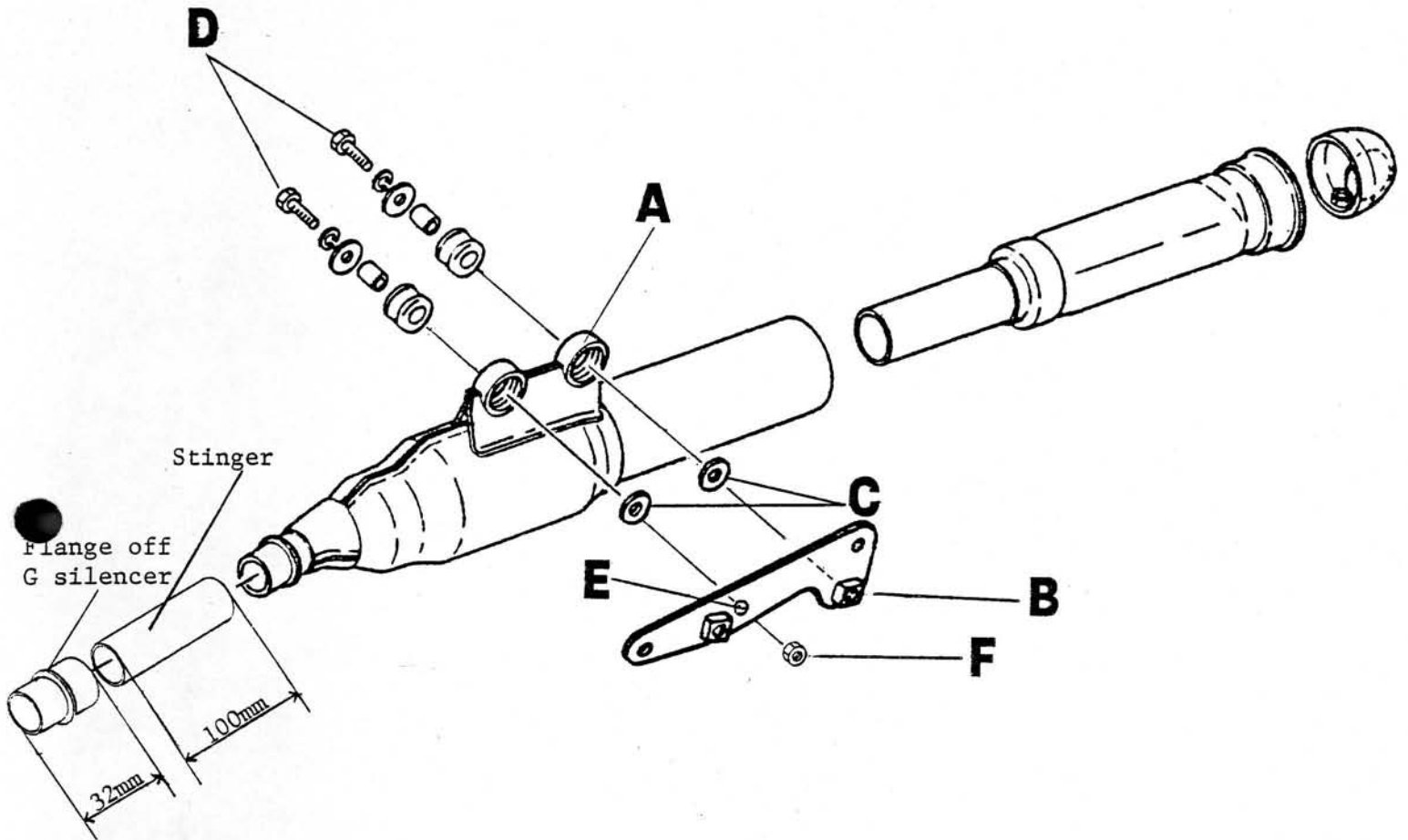

3. Hold F silencer in standard horizontal position, using a $21/64$ " drill, drill front of muffler stay bracket to accept the F silencer front mount (E).

NOTE: Take caution not to drill hole too close to the edge of the bracket.

4. Bolt front mount in place using the same size bolt and washer as the rear mount, but with the addition of a 8mm locknut (F).
5. Cut stinger tip flange off G silencer 32mm long.

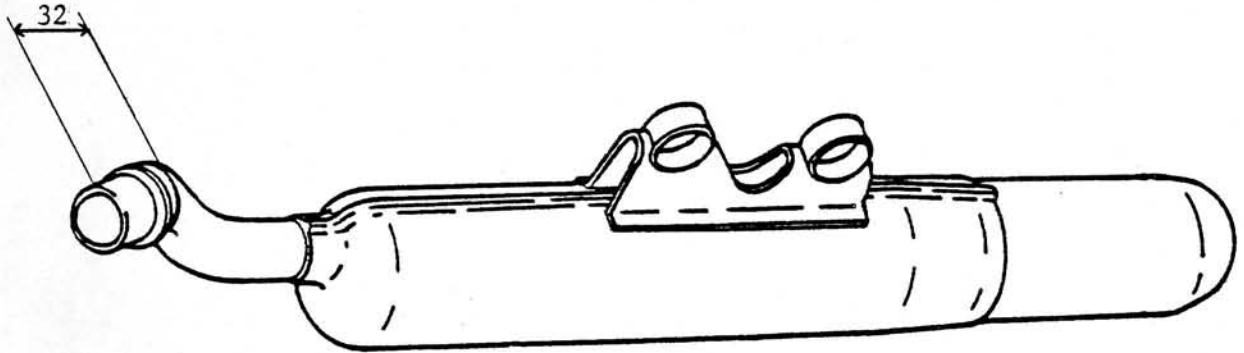

6. Fabricate stinger, measurements must be exactly 23mm I.D. X 1mm thick X 100mm long.
7. Insert stinger into F silencer flange opening about 5 to 10mm. Place flange off G silencer as illustrated below.
8. With exhaust pipe in place and the 32mm flange in place, measure the distance from 32mm flange to the front tip of silencer. Using this measurement cut the stinger to obtain same measurement.

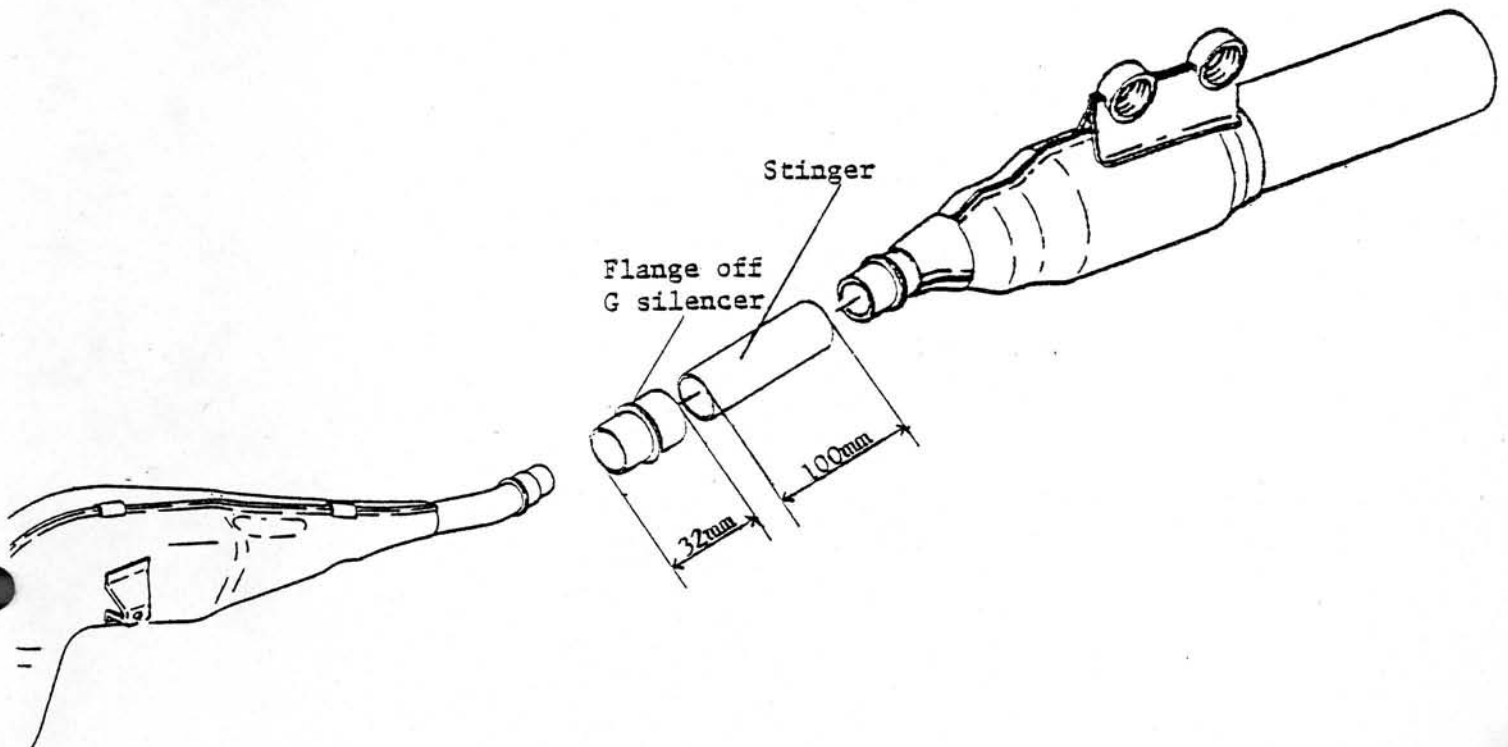

9. Match and align all pieces for smooth flow.
10. Remove all components that may get damaged while tac welding stinger.
11. Tac weld stinger at both ends while held in place, then remove silencer and complete welding.

2. AIR BOX:

1. Remove air box from motorcycle.
2. Cut open area A to match with standard air box opening B.

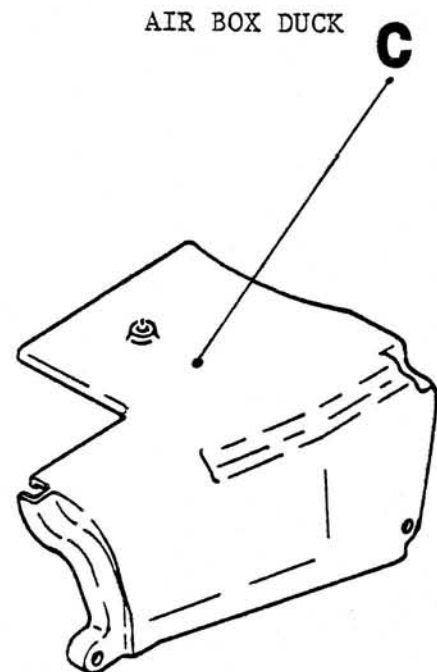
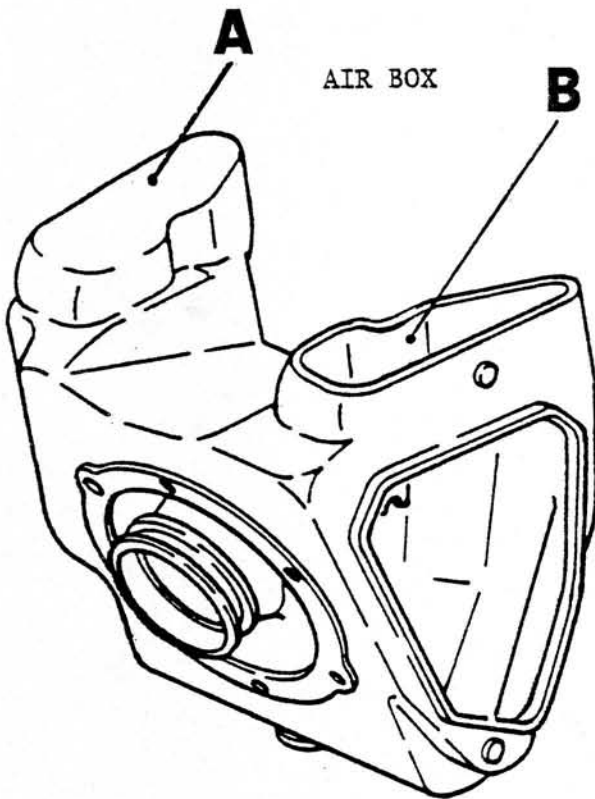

3. Remove air box duct C from motorcycle.

NOTE: This will not be needed any further for dry or dusty conditions.

4. Before installing air box silicone rivets and outer edge of aluminum ring.
5. When installing air filter make sure air filter is seated properly in air box and apply a heavy coating of grease to the filter base to insure sealing. Use the standard filter or follow the air filter - air box alternation as per YZ125G and IT175G to accept the YZ250G air filter and cage. Wrench Report, sent out August 21, 1980.

NOTE: In muddy conditions it will be necessary to better seal the air box openings from mud accessibility from the rear wheel area.

3. CARBURETOR: standard carb with larger main jet (220-230) and a larger power jet #85 (power jet part number 3G2-14231-17).

NOTE: These settings are a starting point only and may vary with conditions.

The carburetion can go momentarily lean after a series of extremely rough bumps. This condition is caused by the Brass, Baffle Ring (part number 537-14153-00) between the main jet and main nozzle.

Trim 1 millimeter off the lower edge as illustrated below.

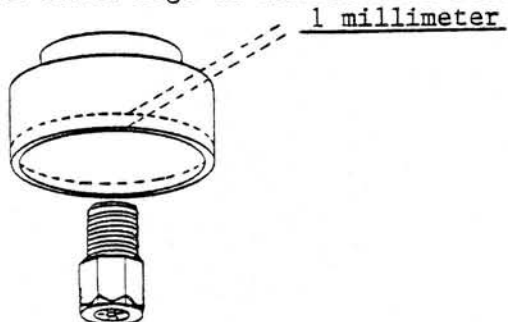

4. GEARING: change rear sprocket to 46 tooth, and in enduro type riding use a 48 tooth, with standard countershaft sprocket.

<u>Part Number</u>	<u>Description</u>
3R6-25446-10-33.....	Sprocket, driven (46T)
3R4-25448-00-XX.....	Sprocket, driven (48T)

5. TIRE SIZE: use a 4.10 X 18 low profile type rear tire for best performance.

6. TOOL POUCH: lock-tite the 3-6mm bolts that secure the tool bag and use larger outer diameter washers.

<u>Qty.</u>	<u>Part Number</u>	<u>Description</u>
3	902-01064-07-00.....	washer, plate

Also stuff tool bag tight with foam or rags so tools will not work there way loose and possibly damage tool bag.

7. OIL: Yamalube R, mixing ratio 32 to 1.
8. SPARK PLUG: Champion N2-G plug gap .027".

WA/dm