



SERVICE INFORMATION	13-1
TROUBLESHOOTING	13-2
HEADLIGHT	13-3
SPEEDOMETER	13-3
HANDLEBAR	13-4
FRONT WHEEL	13-6
FRONT FORK	13-13
STEERING STEM	13-19

## SERVICE INFORMATION

### GENERAL INSTRUCTION

- A jack or other support is required to support the motorcycle.

### TOOL SPECIAL

6 mm Hex wrench	07917-3230000	Commercially available in U.S.A.
Snapping pliers	07914-3230001	
Ball race remover	07946-4300200	
Ball race driver	07953-MA00000	
Steering stem driver	07946-4300100	
Steering stem socket	07916-3710100	
Fork seal driver	07947-3710101	

### COMMON

Bearing driver outer 32 x 35 mm	07746-0010100	Commercially available in U.S.A.
Bearing driver handle outer A	07749-0010000	
Driver pilot 15 mm	07746-0040300	
Socket wrench 30 x 32 mm	07716-0020400	
Extension bar	07716-0020500	
Bearing driver outer, 42 x 47 mm	07746-0010300	

ITEMS		STANDARD	SERVICE LIMIT
Axle shaft runout		_____	0.2 mm (0.01 in)
Front wheel rim runout	Radial	_____	2.0 mm (0.08 in)
	Axial	_____	2.0 mm (0.08 in)
Brake drum I.D.		130 mm (5.12 in)	131 mm (5.16 in)
Brake shoe thickness		4.0 mm (0.16 in)	2.0 mm (0.1 in)
Front fork spring free length		617.5 mm (24.31 in)	605.1 mm (24 in)
Front fork tube runout		_____	0.2 mm (0.008 in)
Front fork oil level		181 mm (7.1 in)	_____
Front fork air pressure		30 kPa (0.3 kg-m <sup>2</sup> , 4.3 psi)	_____
Wheel bearing	Radial	_____	0.10 mm (0.004 in)
	Axial	_____	0.05 mm (0.002 in)



**FRONT WHEEL  
BRAKE/SUSPENSION/STEERING**

---

**TORQUE VALUES**

Steering stem nut	80–120 N·m (8–12 kg·m, 58–87 ft-lb)
Fork top bridge pinch bolt	18–25 N·m (1.8–2.5 kg·m, 13–18 ft-lb)
Handlebar holder	18–30 N·m (1.8–3.0 kg·m, 13–22 ft-lb)
Steering stem pinch bolt	18–30 N·m (1.8–3.0 kg·m, 13–22 ft-lb)
Front axle	50–80 N·m (5.0–8.0 kg·m, 36–58 ft-lb)
Front axle shaft holder	10–14 N·m (1.0–1.4 kg·m, 7–10 ft-lb)
Headlight cover	3–6 N·m (0.3–0.6 kg·m, 2–4 ft-lb)
Fork cap bolt	15–30 N·m (1.5–3.0 kg·m, 11–22 ft-lb)
Spokes	2.5–5 N·m (0.25–0.5 kg·m, 1.7–3.6 ft-lb)
Rim lock	10–15 N·m (1.0–1.5 kg·m, 7–11 ft-lb)
Brake arm	8–12 N·m (0.8–1.2 kg·m, 6–9 ft-lb)

**TROUBLESHOOTING**

**Hard Steering**

1. Steering stem nut too tight
2. Faulty steering stem bearings
3. Damaged steering stem bearing
4. Insufficient tire pressure

**Steers to One Side or Does Not Track Straight**

1. Bent front forks
2. Bent front axle, wheel installed incorrectly
3. Unequal air pressure in each fork tube.
4. Unequal oil quantity in each fork tube.

**Front Wheel Wobbling**

1. Distorted rim
2. Worn front wheel bearing
3. Distorted spokes
4. Faulty tire
5. Axle not tightened properly

**Soft Suspension**

1. Weak fork springs
2. Insufficient fluid in front forks
3. Incorrect fork air pressure

**Hard Suspension**

1. Incorrect fluid weight in front forks
2. Incorrect fork air pressure
3. Fork tube bent

**Front Suspension Noise**

1. Slider binding
2. Insufficient fluid in forks
3. Loose front fork fasteners

**Improper Brake Performance**

1. Incorrect adjustment of lever
2. Brake shoes contaminated
3. Brake shoes worn
4. Brake cam worn
5. Brake drum worn
6. Brake arm serrations improperly engaged





## HEADLIGHT

### HEADLIGHT REMOVAL

Unscrew the headlight case mounting bolts and remove the headlight case.

MOUNTING BOLTS

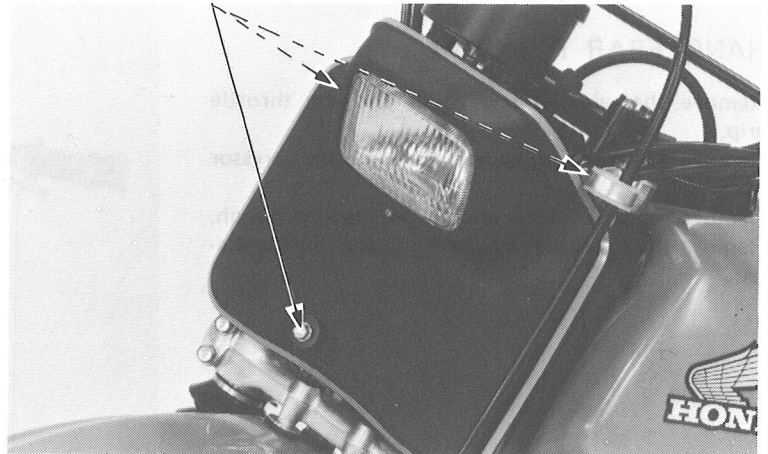

Disconnect the headlight wire connectors.  
Remove the headlight mounting and adjusting screws.  
Remove the headlight.

### HEADLIGHT INSTALLATION

Install the headlight in the reverse order of removal.  
Adjust the headlight vertical beam.

HEADLIGHT

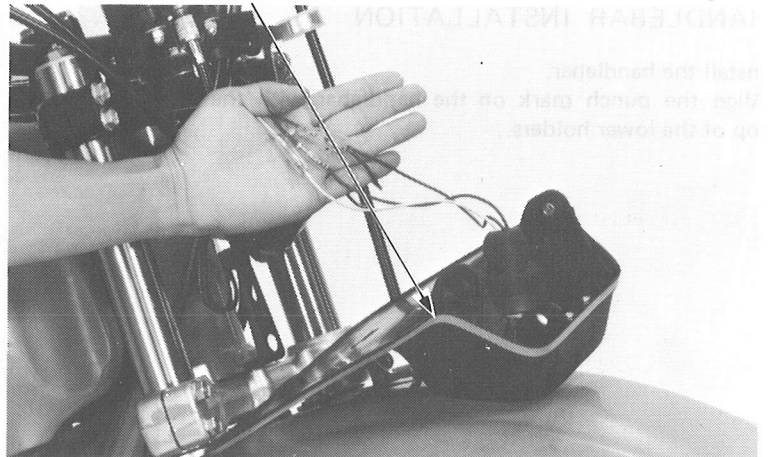

## SPEEDOMETER

### SPEEDOMETER REMOVAL

Remove the headlight.  
Disconnect the speedometer cable.  
Remove the speedometer mounting nuts and speedometer.

### SPEEDOMETER INSTALLATION

Install the speedometer in the reverse order of removal.

SPEEDOMETER CABLE

SPEEDOMETER

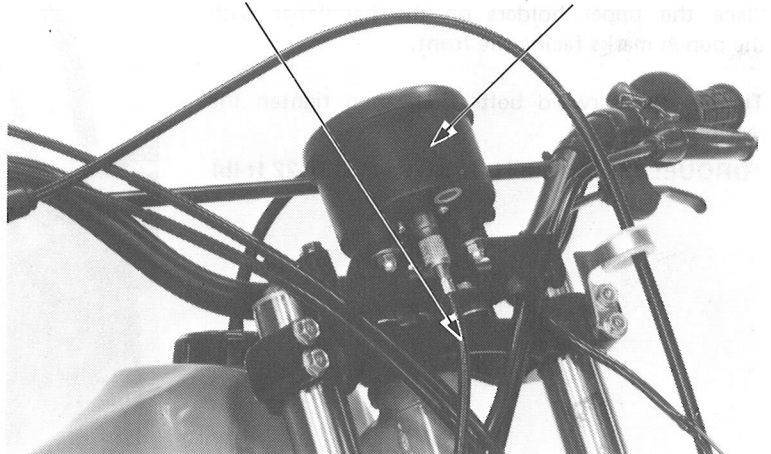

## HANDLEBAR

### HANDLEBAR REMOVAL

Remove the wire harness bands and the throttle grip.  
Remove the front brake and manual decompressor lever.  
Remove the clutch lever and the engine stop switch.  
Remove the handlebar holder bolts and the handlebar.

ENGINE STOP SWITCH

THROTTLE GRIP

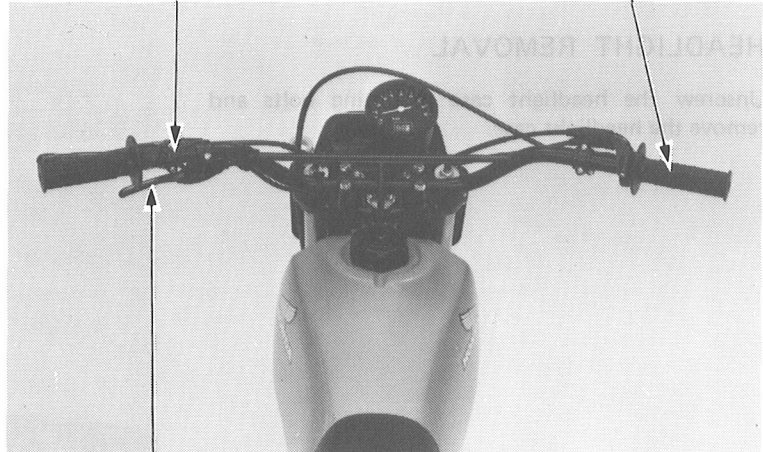

MANUAL DECOMPRESSOR LEVER

### HANDLEBAR INSTALLATION

Install the handlebar.  
Align the punch mark on the handlebar with the top of the lower holders.

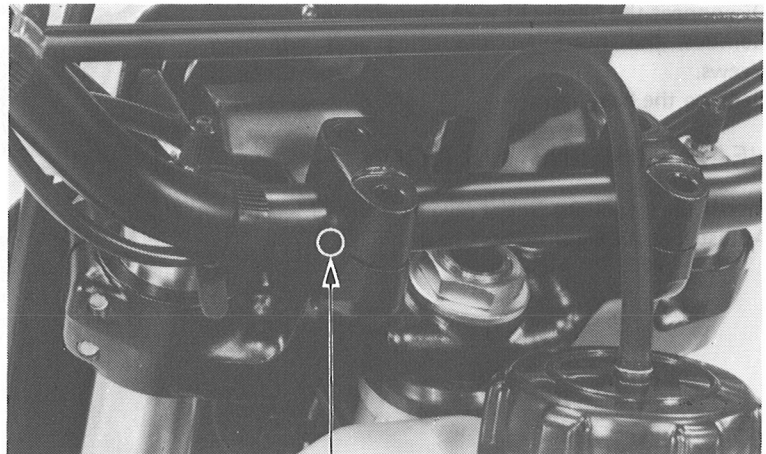

PUNCH MARK

Place the upper holders on the handlebar with the punch marks facing the front.

Tighten the forward bolts first, then tighten the rear bolts.

**TORQUE: 18–30 N·m (1.8–3.0 kg·m, 13–22 ft·lb)**

UPPER HOLDER





Install the front brake lever bracket, aligning the handlebar punch mark with the brake lever bracket split.  
Tighten the pinch screw.

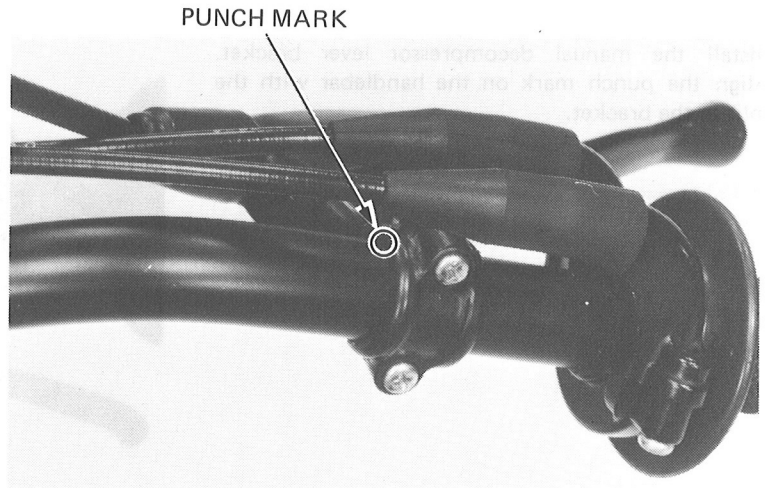

Apply grease to the throttle grip area of the handlebar and install the throttle grip.  
Align the punch mark on the handlebar with the split of the throttle grip housing.  
Tighten the screws.

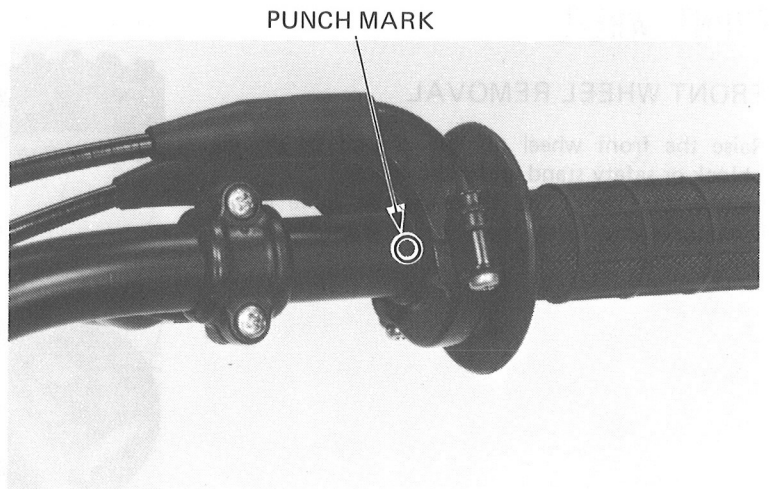

Install the clutch lever bracket.  
Align the punch mark on the handlebar with the split in the clutch lever bracket.  
Install the engine stop switch.

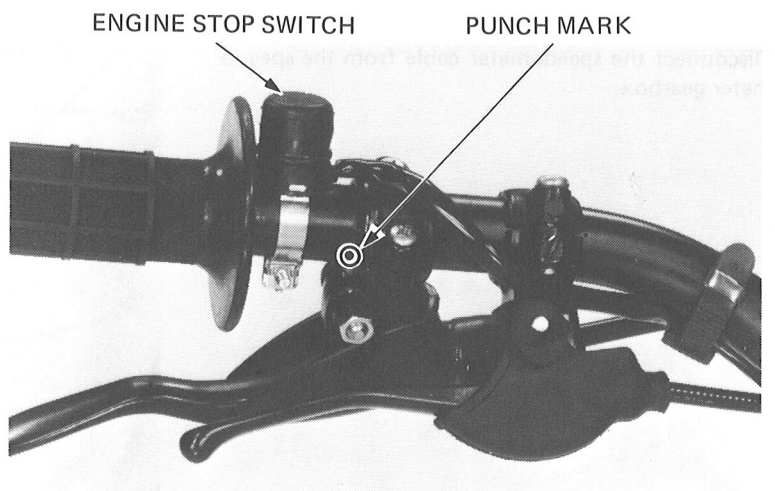

## FRONT WHEEL BRAKE/SUSPENSION/STEERING



Install the manual decompressor lever bracket. Align the punch mark on the handlebar with the split in the bracket.

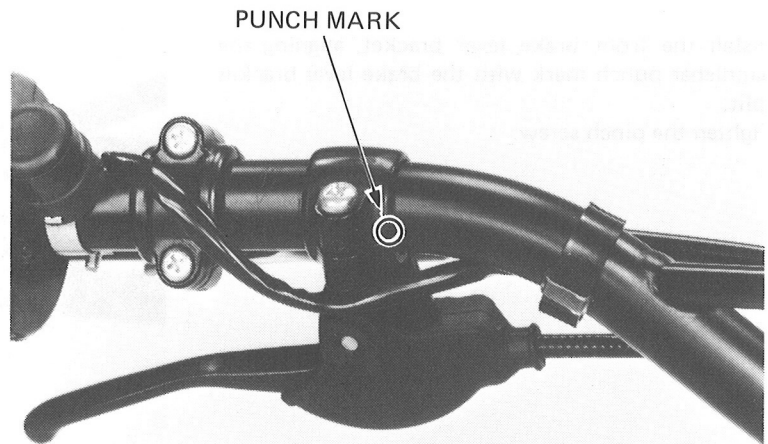

## FRONT WHEEL

### FRONT WHEEL REMOVAL

Raise the front wheel off the ground by placing a block or safety stand under the engine. Loosen the two bolts attaching the cable guide. Disconnect the front brake cable from the brake arm.

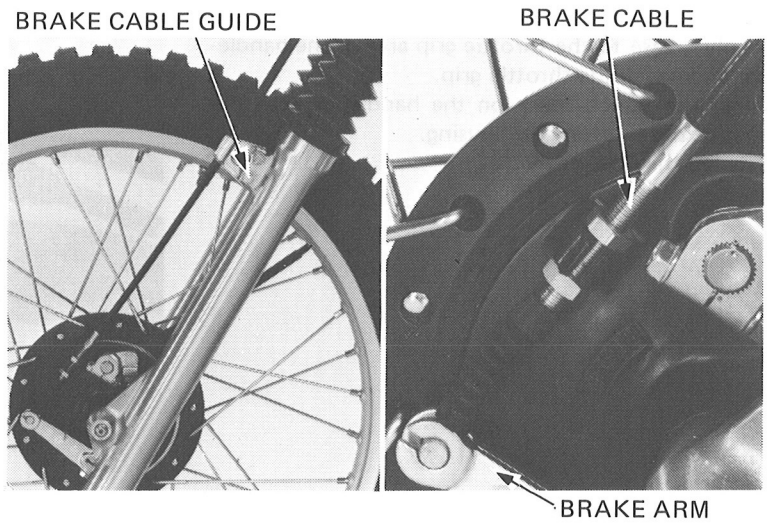

Disconnect the speedometer cable from the speedometer gearbox.

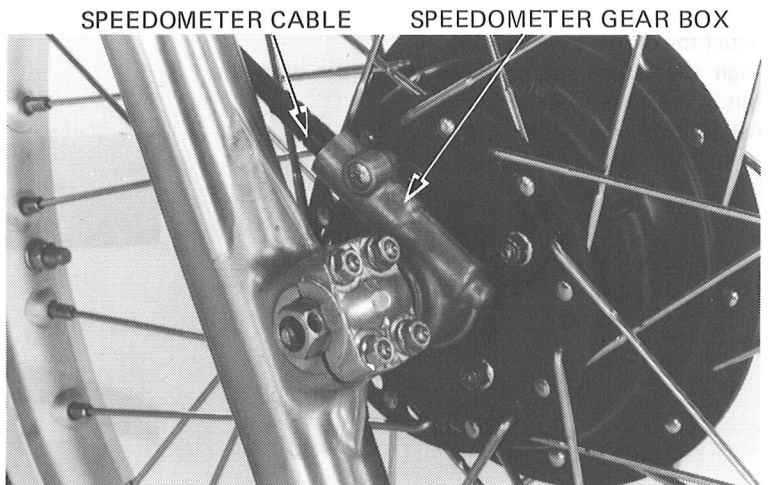





Loosen the axle shaft holder nuts and remove the front axle.  
Remove the front wheel.

AXLE SHAFT HOLDER NUT

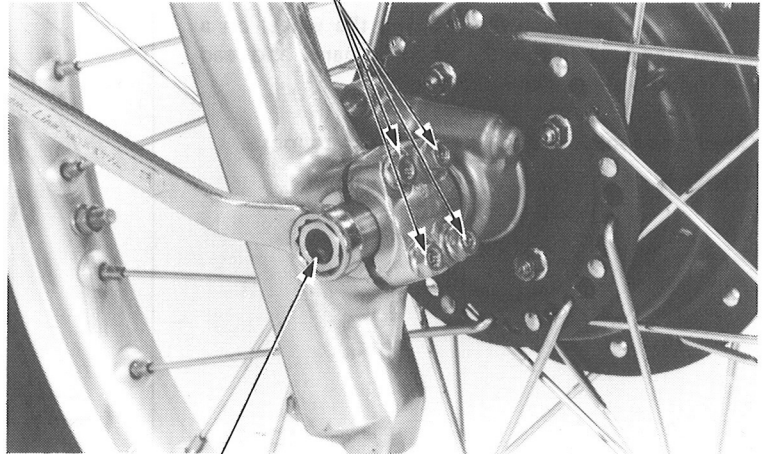

FRONT AXLE

### AXLE INSPECTION

Set the axle in V blocks and measure the runout. The actual runout is 1/2 of the total indicator reading.

SERVICE LIMIT: 0.2 mm (0.01 in)

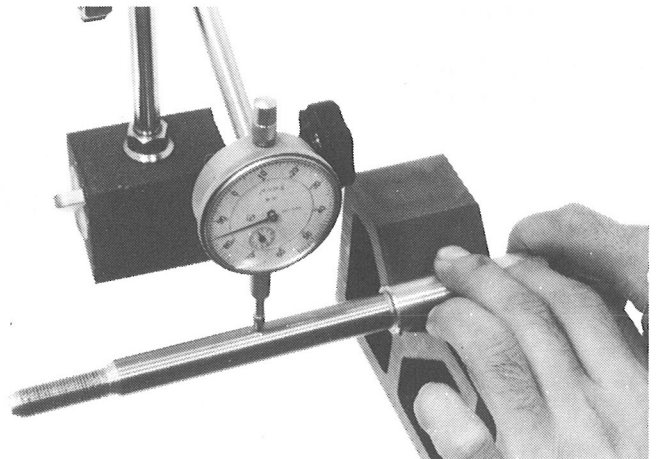

### WHEEL BEARING

Check the wheel bearing play by placing the wheel on a truing stand and spinning the wheel by hand. Replace the bearings with new ones if they are noisy or have excessive play.

SERVICE LIMIT:  
0.05 mm (0.002 in)

SERVICE LIMIT:  
0.10 mm (0.004 in)

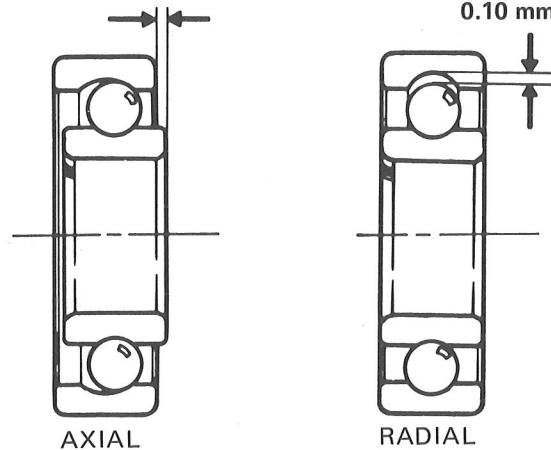

## FRONT WHEEL BRAKE/SUSPENSION/STEERING



# HONDA XR500R

### WHEEL

Check the rim runout by placing the wheel on a truing stand. Then spin the wheel by hand, and read the runout using a dial indicator.

Check the spokes and tighten any that are loose.

**TORQUE: 2.5 – 0.5 N·m (0.25–0.5 kg·m,  
2.8 – 3.6 ft·lb)**

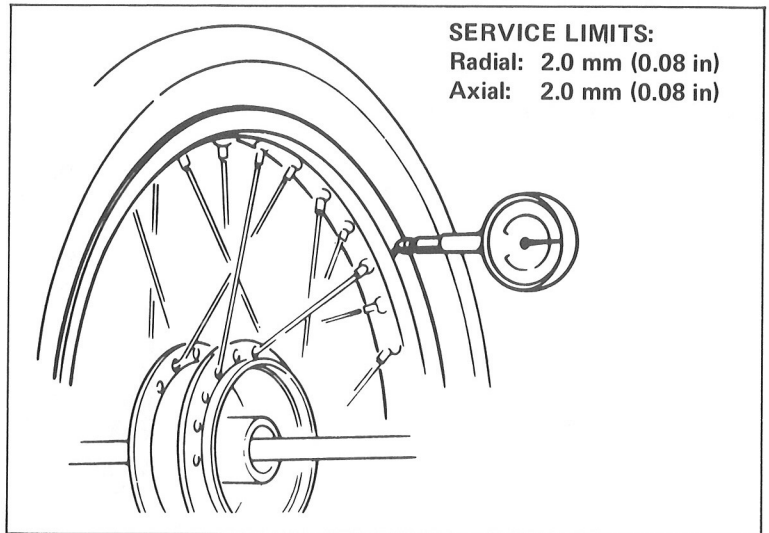

### BRAKE DRUM

Remove the brake panel.  
Measure the drum I.D.

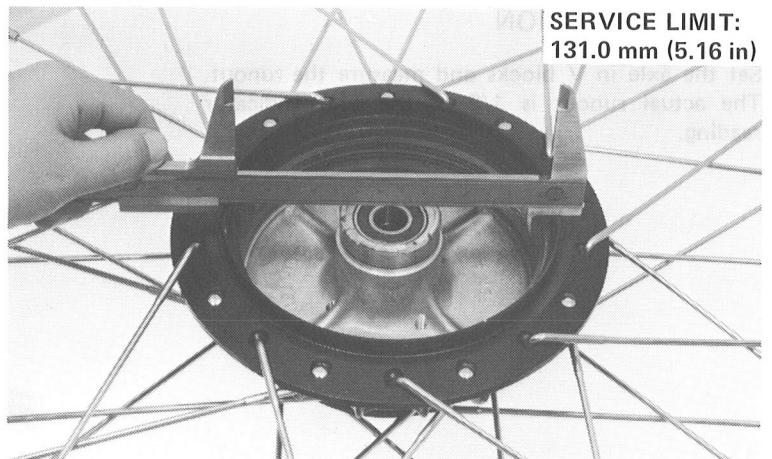

### BRAKE LINING

Measure the brake lining thickness.

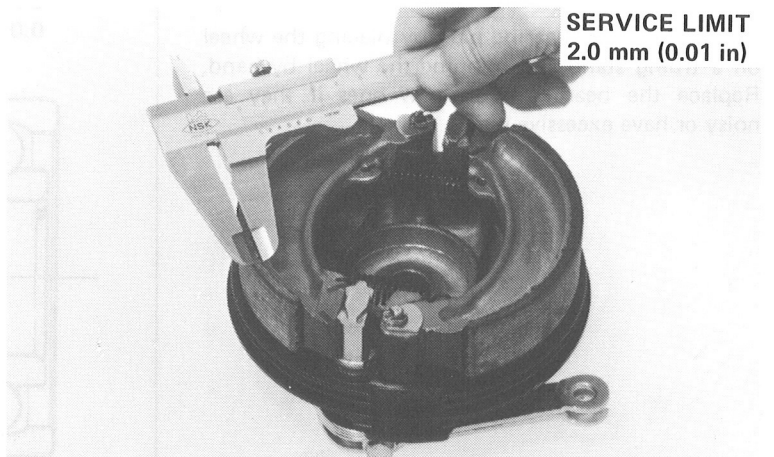



**BRAKE SHOE REPLACEMENT**

Remove the cotter pin and plain washer.  
Remove the brake shoes.  
Apply grease to the brake cams and install new brake shoes.  
Install the plain washer and cotter pin.

**WARNING**

*Grease on the brake linings reduces stopping power.  
Keep grease off the brake linings. Wipe excess grease off the cam.  
Do not remove the brake arm rod when the brake shoes are replaced.*

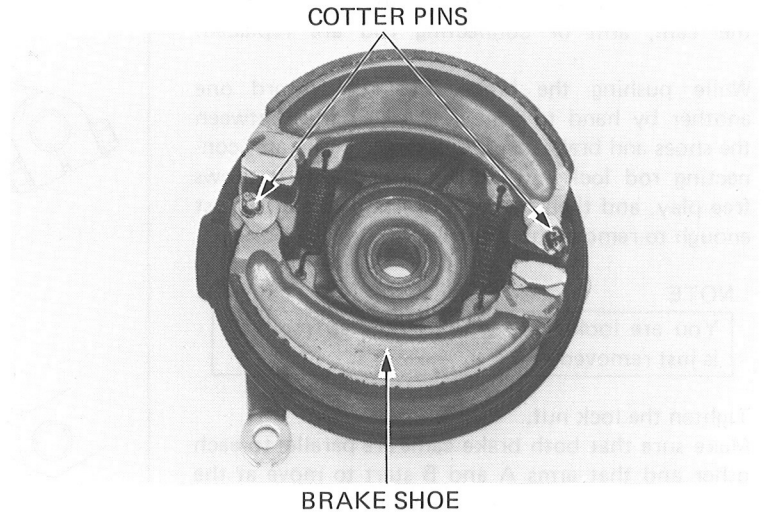

**BRAKE ARM, BRAKE CAM AND  
BRAKE ARM CONNECTING ROD RE-  
PLACEMENT**

Remove the shoes.  
Remove the bolts attaching the brake cam to the brake arm.  
Remove the brake arm with brake rod.

Install a new brake arm, brake cam and brake cam connecting rod.

**CAUTION:**

*Adjust the brake arm connecting rod whenever the brake cam, brake arm or connecting rod are replaced.*

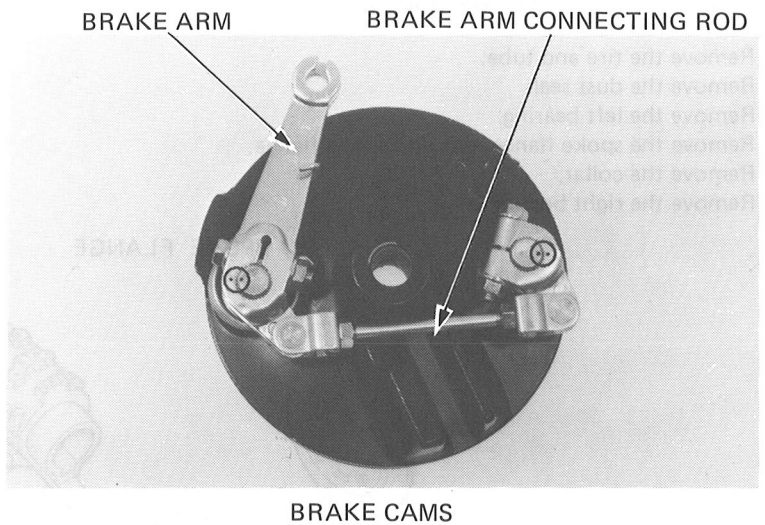

Install the brake arms aligning the punch marks with the cam punch marks.  
Tighten the brake arm bolts.

**TORQUE:** 8–12 N·m  
(0.8–1.2 kg-m, 6–9 ft-lb)

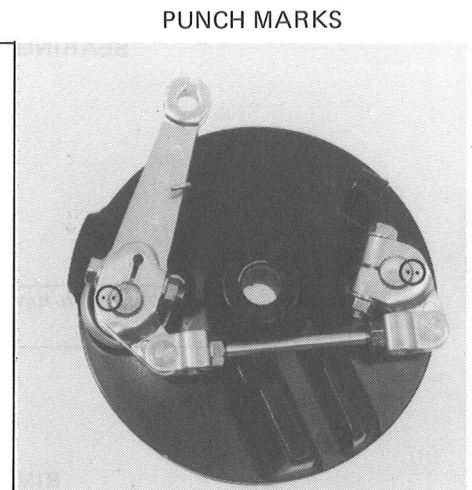
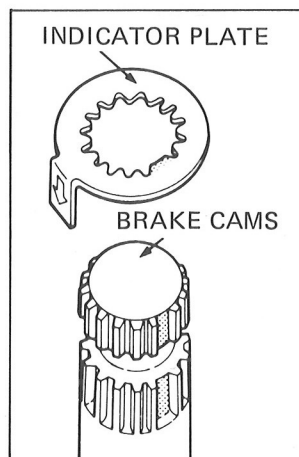

## FRONT WHEEL BRAKE/SUSPENSION/STEERING



Adjust the brake arm connecting rod whenever the cam, arm or connecting rod are replaced.

While pushing the brake shoes in toward one another by hand to remove any clearance between the shoes and brake cams, loosen the brake arm connecting rod lock nut, turn the rod until it shows free play, and then turn the rod in direction A just enough to remove that free play.

### NOTE

You are looking for the point that free play is just removed.

Tighten the lock nut.

Make sure that both brake cams are parallel to each other and that arms A and B start to move at the same time when the brake is applied.

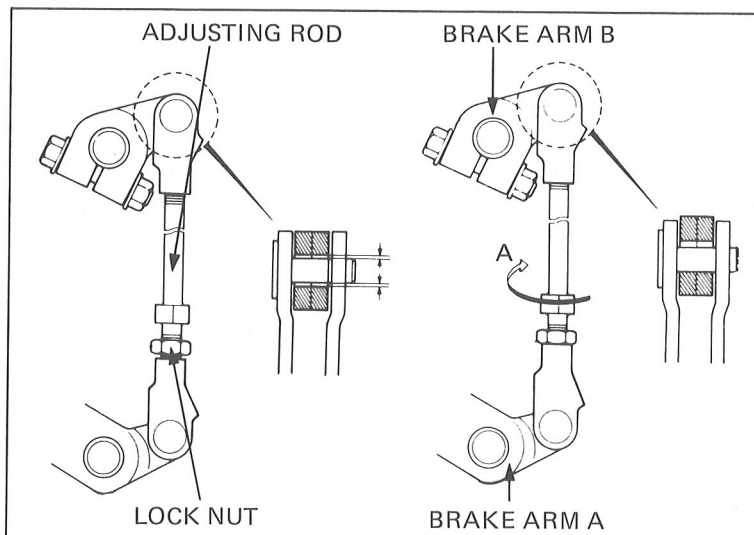

## FRONT WHEEL DISASSEMBLY

Remove the tire and tube.

Remove the dust seal.

Remove the left bearing.

Remove the spoke flange nuts and spoke flange.

Remove the collar.

Remove the right bearing.

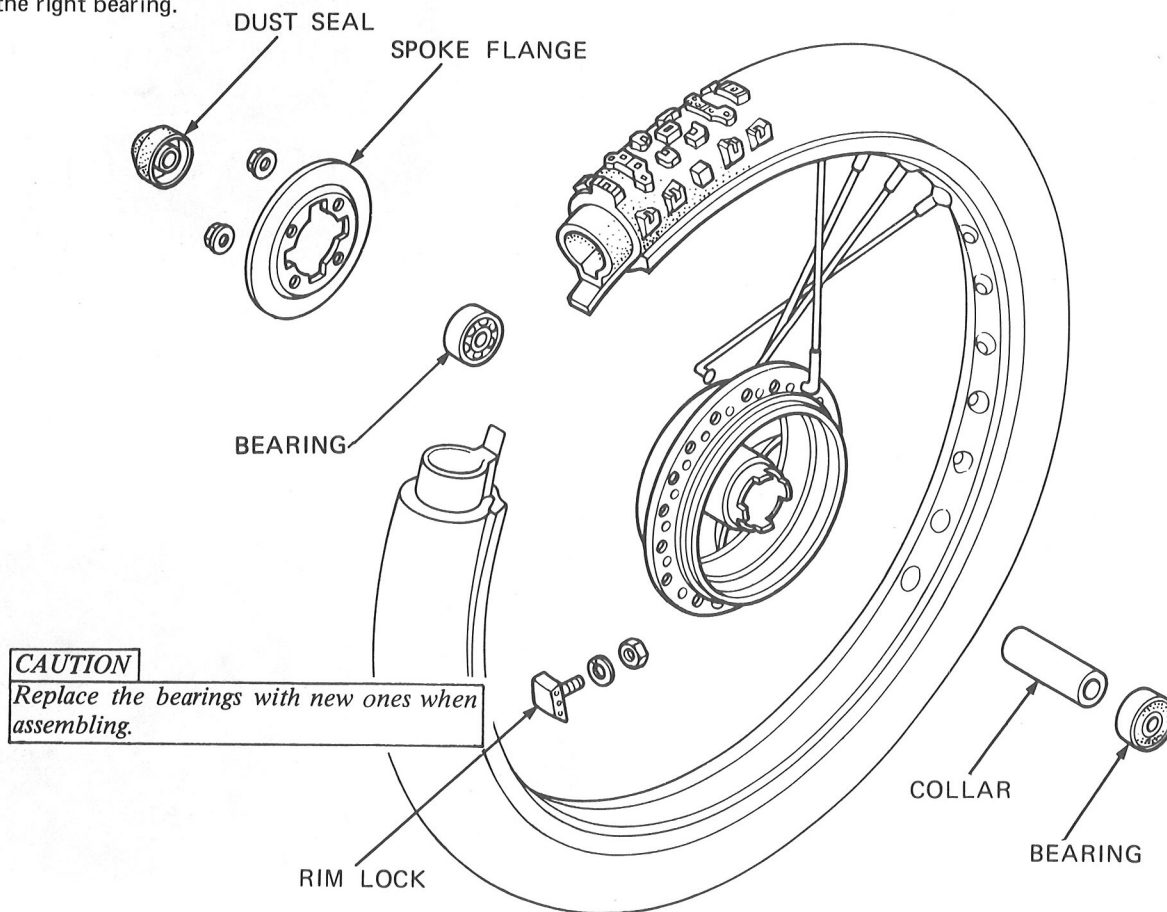





### FRONT WHEEL ASSEMBLY

Pack the bearing cavities with grease.  
Drive in the left bearing.  
Install the distance collar.  
Drive in the right bearing.

#### NOTE

Install the bearings with the sealed end toward the outside. Be sure to drive the bearing in squarely.

#### WARNING

*Grease on the brake linings reduces stopping power. Keep grease off the brake linings. Wipe excess grease off the cam.*



TOOLS  
BEARING DRIVER OTR 32x35 mm  
BEARING DRIVER HANDLE OUTER A  
DRIVER PIVOT 15 mm

Insert the tang on the gear box in the slot in the front wheel and install the gear box on the wheel.

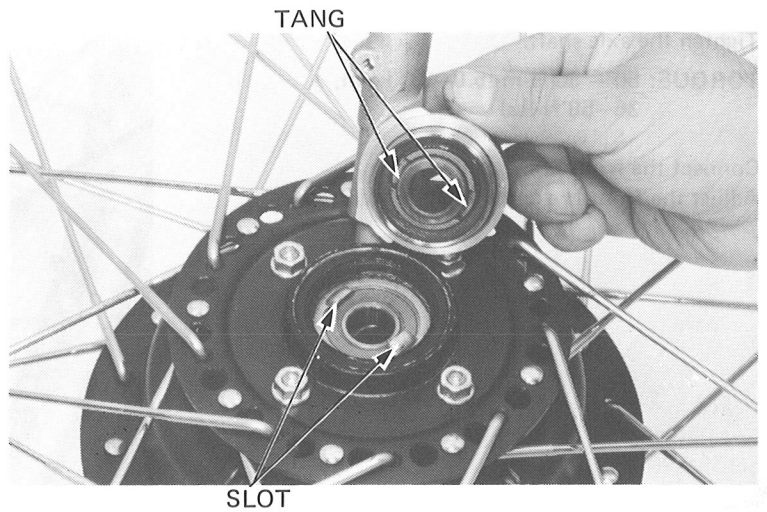

### FRONT WHEEL INSTALLATION

Clean the axle shaft and holder.  
Install the holder with the "UP" mark facing upwards.  
Install the axle shaft nuts but do not tighten at this time.

#### NOTE

Set the tang on the gear box under the tab on the fork tube.

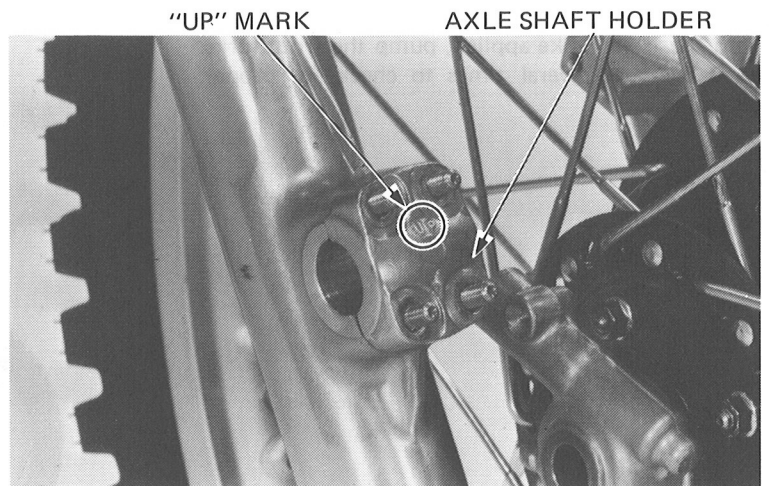

## FRONT WHEEL BRAKE/SUSPENSION/STEERING



**HONDA**  
**XR500R**

Insert the axle shaft through the wheel hub from the right side.

### NOTE

The tang on the fork leg should be located in the slot in the brake panel.

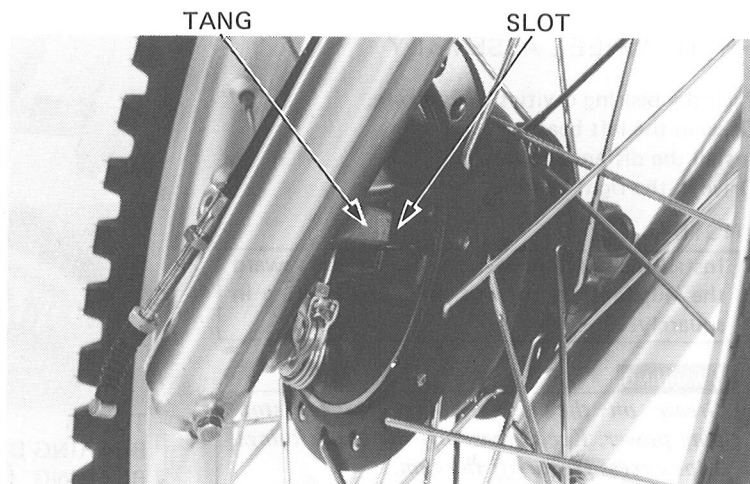

Tighten the axle shaft.

**TORQUE: 50 – 80 N·m (5.0–8.0 kg-m,  
36–58 ft-lbs)**

Connect the front brake cable.

Adjust the front brake free play (Page 3-15).

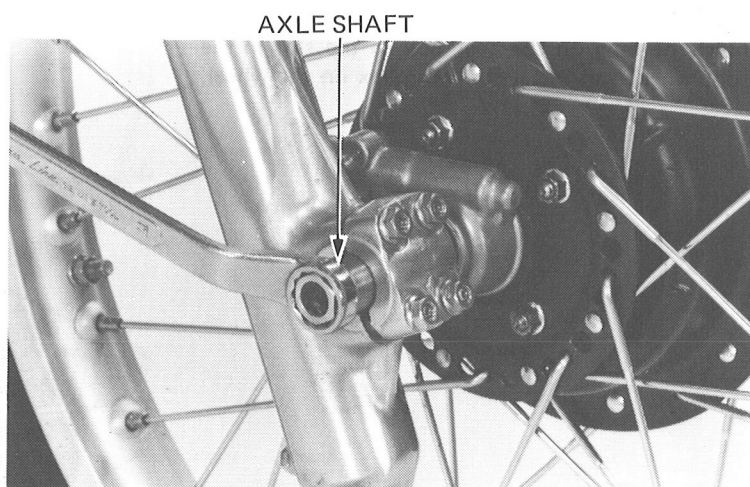

With the front brake applied, pump the front forks up and down several times to check for proper operation.





Tighten the axle shaft holder nuts; the upper nuts first, then the lower nuts.

**TORQUE:** 10–14 N·m  
(1.0–1.4 kg·m, 7–10 ft·lb)

Connect the speedometer cable to the speedometer gear box.

AXLE SHAFT HOLDER

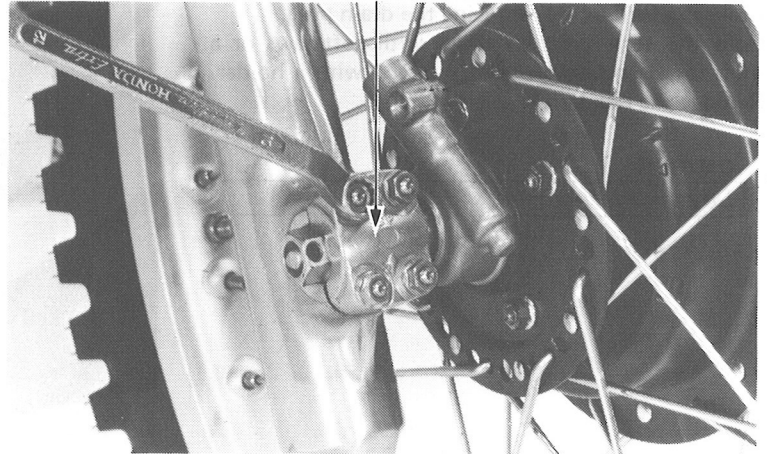

## FRONT FORKS

### REMOVAL

Remove the front wheel.  
Loosen the top bridge and steering stem bolts.  
Remove the front forks.

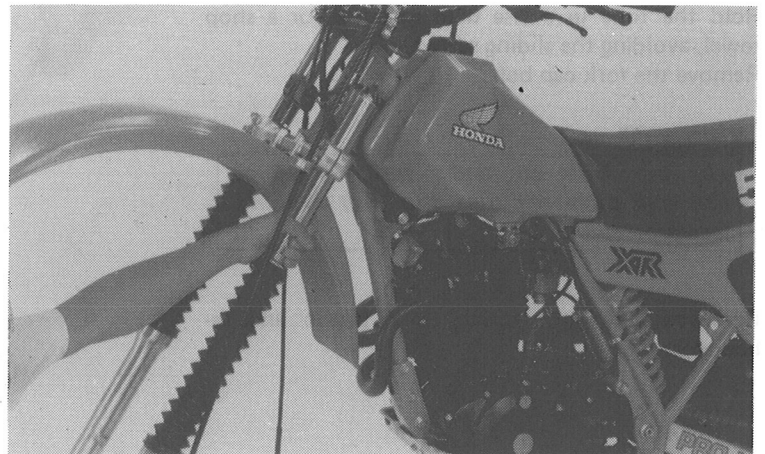

### DISASSEMBLY

Remove the rubber cap.  
Release the air from each fork tube.

**WARNING**

*Be sure to release front fork air pressure before disassembling to prevent parts from becoming projectiles.*

FRONT FORK TUBE

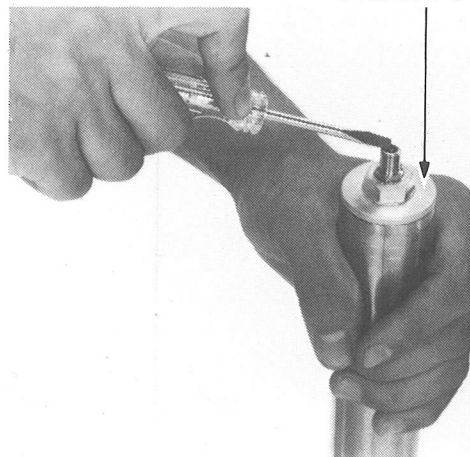

**FRONT WHEEL  
BRAKE/SUSPENSION/STEERING**



**HONDA  
XR500R**

Drain the fork oil by removing the drain plug.  
Hold the fork slider in a vise with soft jaws or a shop towel and hold the fork piston with a holder.  
Remove the hex bolt.

**CAUTION:**

*Do not distort the fork slider in a vise.*

6 mm HEX WRENCH (07917-3230000)



Hold the tube in a vise with soft jaws or a shop towel, avoiding the sliding surface.  
Remove the fork cap bolt.

**WARNING**

*The cap bolts are under spring pressure.  
Use care when removing and wear eye and  
face protection.*

FORK BOLT

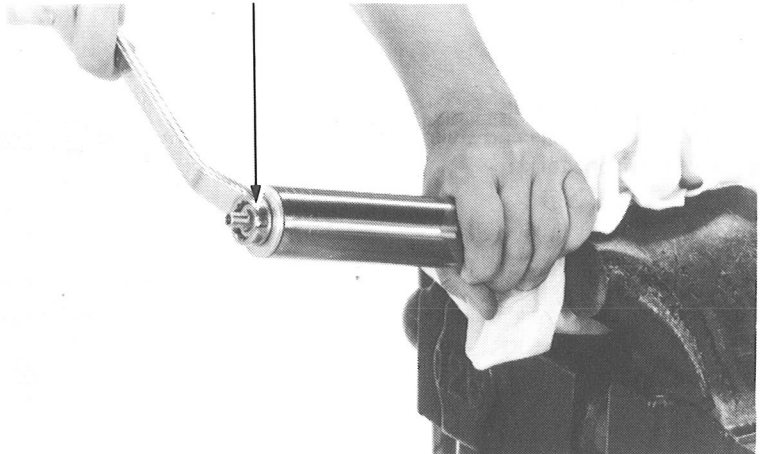

Removing the fork spring, fork piston and rebound spring.

Pour out any remaining fork fluid.

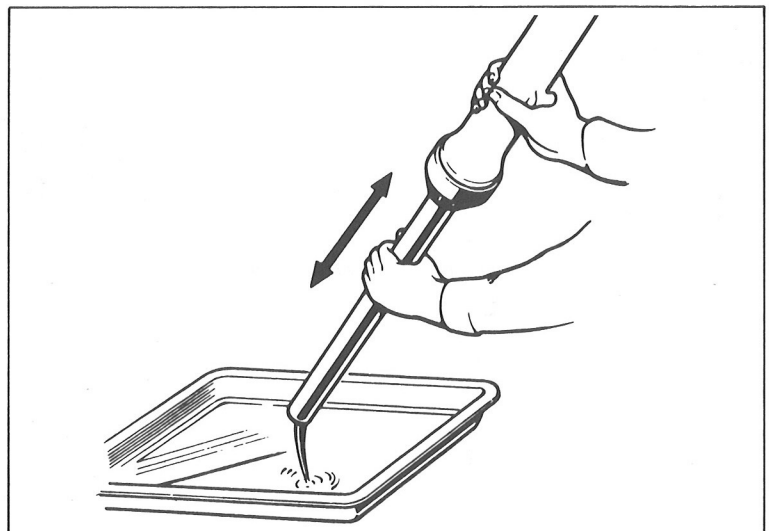





Remove the dust seal.  
Remove the circlip with snap-ring pliers, then  
remove the back-up plate.

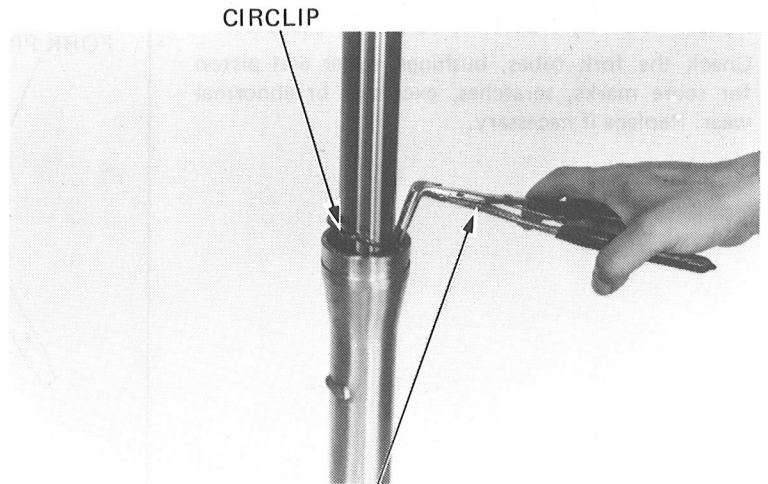

SNAP-RING PLIERS (07914-3230001)

In quick successive back and forth strokes, pull  
the fork tube out from the slider.  
The slider bushing gives resistance and the fork  
tube bushing must force it out.  
Remove the oil seal, back-up ring and slider bushing  
from the fork tube.

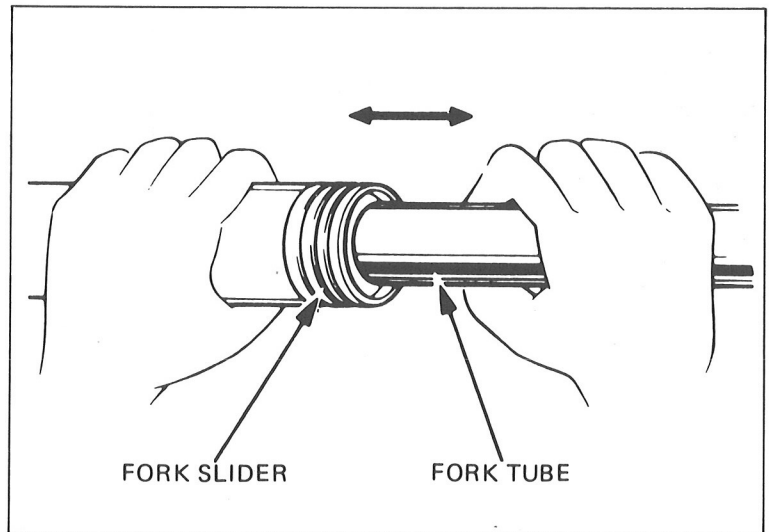

**INSPECTION  
SPRING**

Measure the fork spring free length.

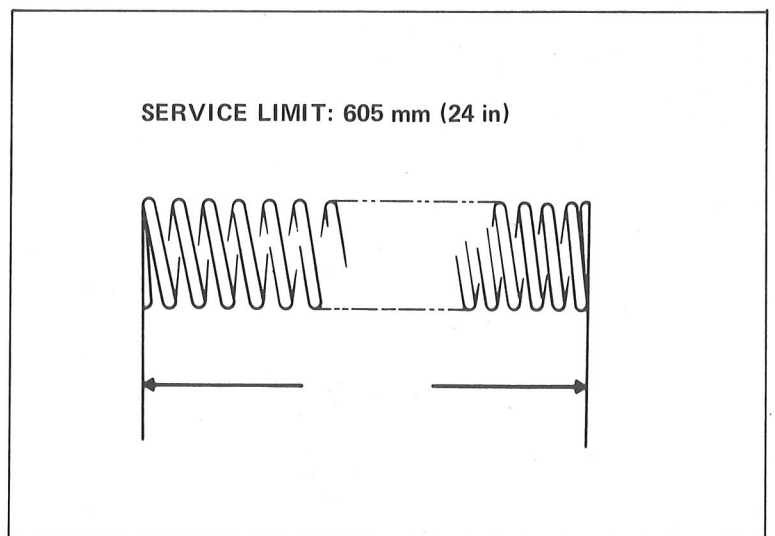

## FORK TUBE/FORK PISTON/SLIDER

Check the fork tubes, bushings, slider and piston for score marks, scratches, excessive or abnormal wear. Replace if necessary.

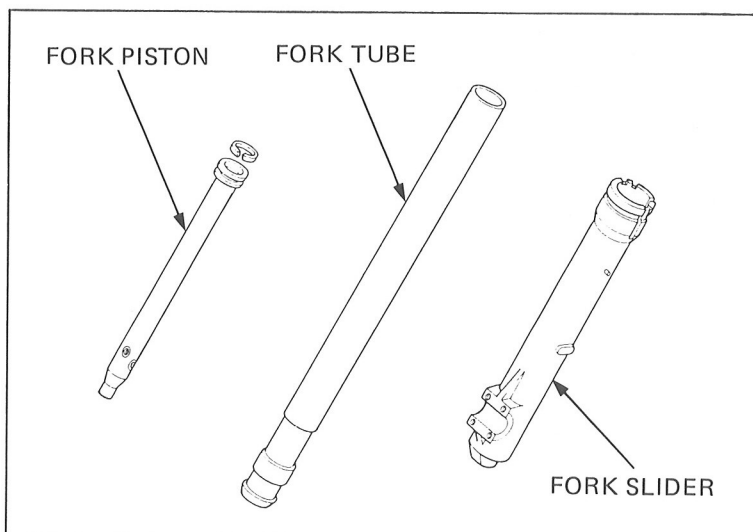

Set the fork tube on V blocks and measure the runout. Take 1/2 of total indicator reading to determine the actual runout.

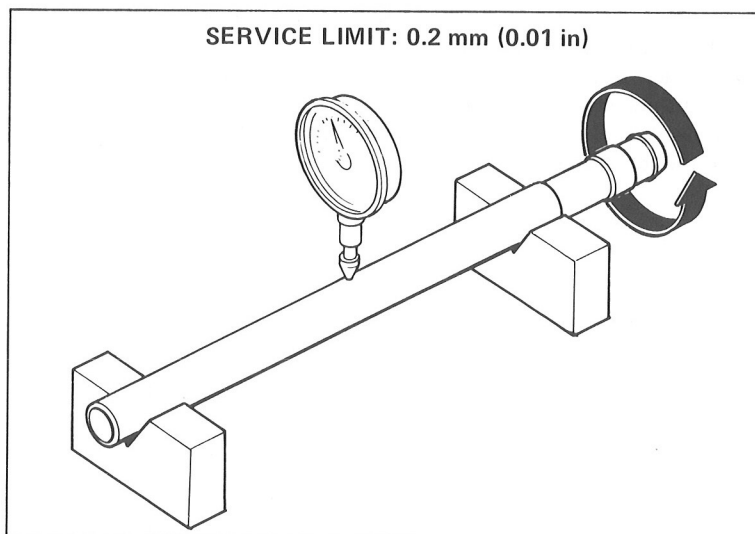

Check the bushings for excessive wear or scratches. If copper appears on more than 3/4 of the entire surface, replace the bushings. Replace the back-up ring if there is distortion at the points shown. Check the fork piston ring for wear or damage. Check the rebound spring for fatigue or damage.

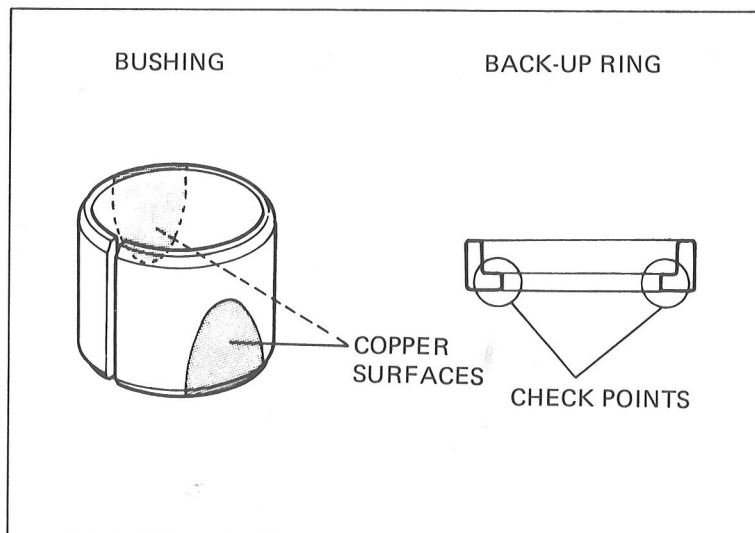



**ASSEMBLY**

Clean all parts with non-flammable or high flash point solvent.

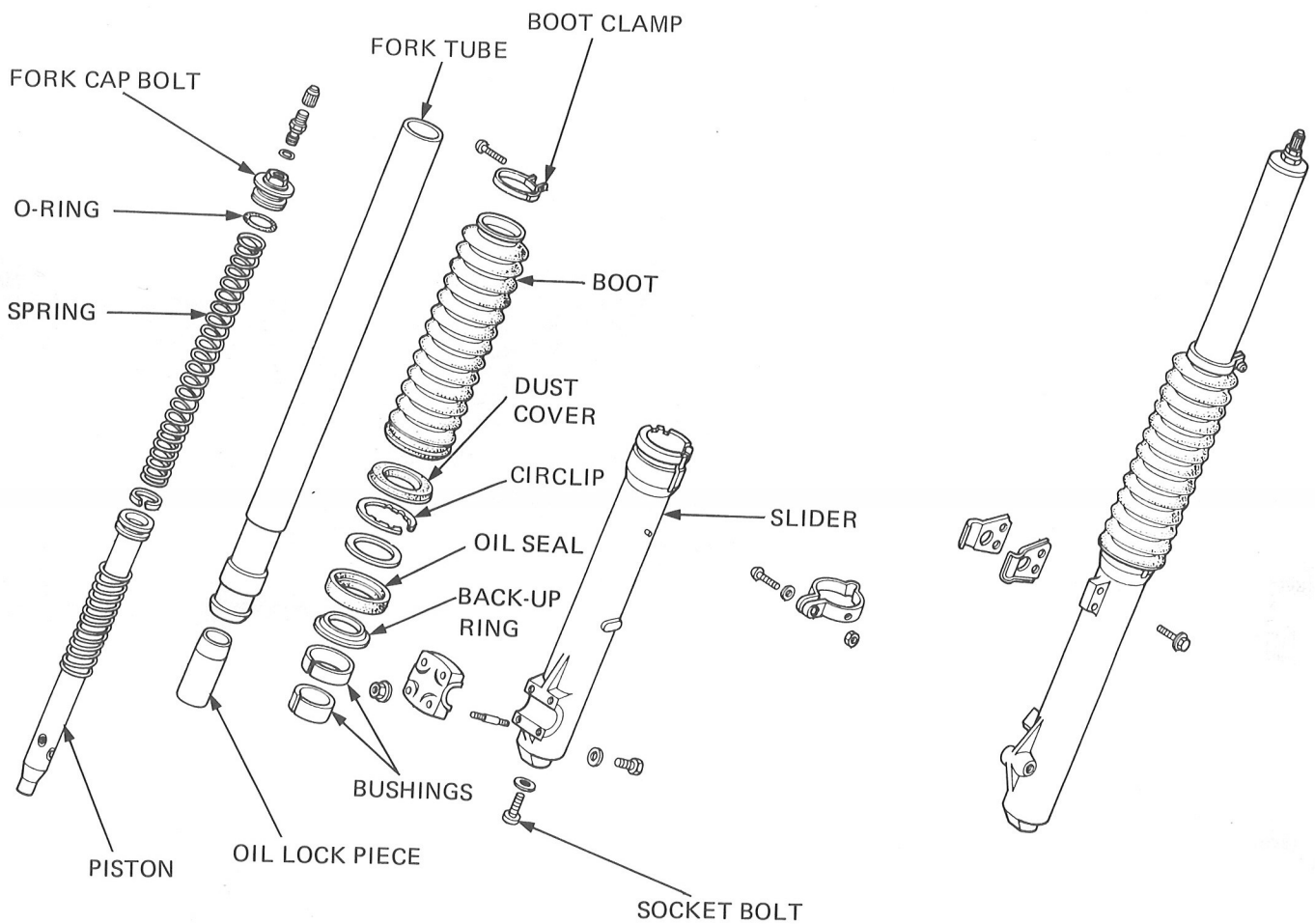



## FRONT WHEEL BRAKE/SUSPENSION/STEERING

Place the slider bushing over the fork tube and rest it on the slider. Put the back-up ring and an old bushing or equivalent tool on top.

Drive the bushing into place with the seal driver. Remove the old bushing.

Install the back-up ring.

Coat a new oil seal with ATF and install it with the seal markings facing up. Drive the seal with the seal driver.

### NOTE

If additional seal depth is needed, install the back-up plate and repeat driving the seal in.

Install the back-up plate, circlip and dust cover. Install the rebound spring and piston into the fork tube.

Place the oil lock piece over the piston end and insert the fork tube into the slider.

Apply a locking agent to the socket bolt and torque it.

### NOTE

Temporarily install the fork spring and fork bolt to tighten the hex bolt.

**TORQUE: 8–12 N·m (0.8–1.2 kg·m, 6–9 ft·lb)**

Pour in the specified amount of ATF.

**SPECIFIED FLUID: ATF**

**CAPACITY: 345–350 cc (11.7–11.8 oz)**

Compress the front fork and measure the oil level from the top of the tube.

### NOTE

- Be sure the oil level is the same in both fork tubes.

**STANDARD OIL LEVEL: 181 mm (7.1 in)**

Maximum level	161 mm (6.3 in)	Slightly stiffer fork spring effect when fork is charged with standard air pressure.
Minimum oil level	201 mm (8.0 in)	Slightly softer fork spring effect when fork is charged with standard air pressure.

Install the fork spring into the fork tube after wiping oil off of it.

Install and torque the fork cap bolt.

**TORQUE: 15–30 N·m (1.5–3.0 kg·m, 11–22 ft·lb)**

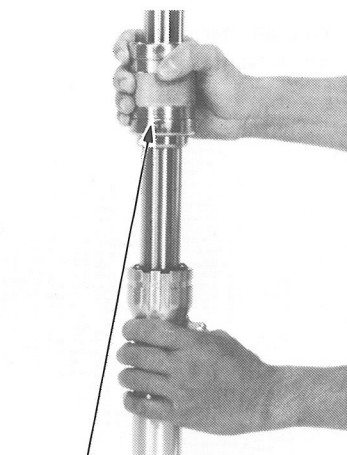
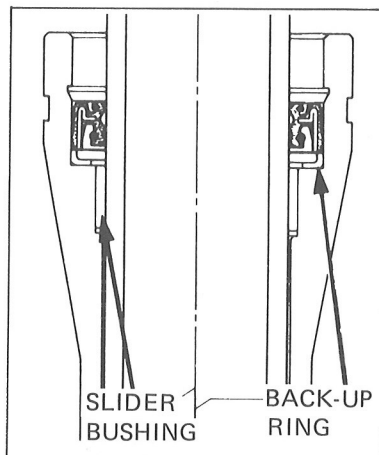

FORK SEAL DRIVER  
(07947-3710100)

6 mm HEX WRENCH (Commercially available)

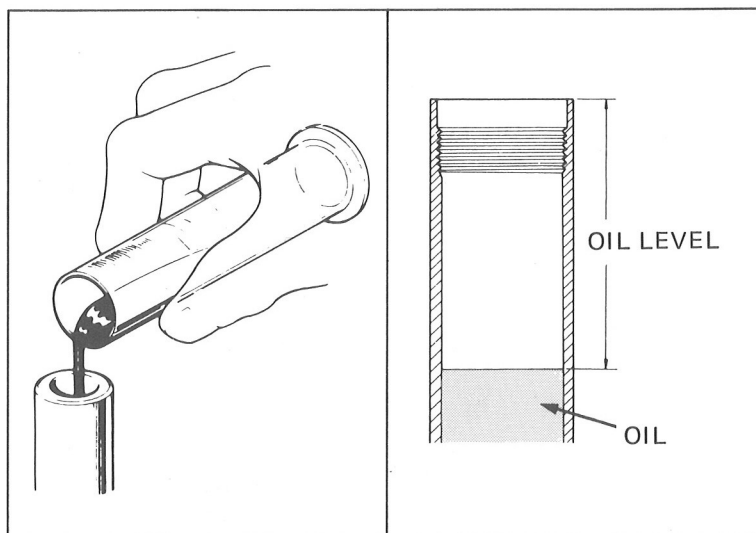





## INSTALLATION

Install the fork tubes in the bridge and steering stem while rotating them by hand.

### NOTE

Ensure that the lower groove of each tube aligns with the top of the fork bridge.

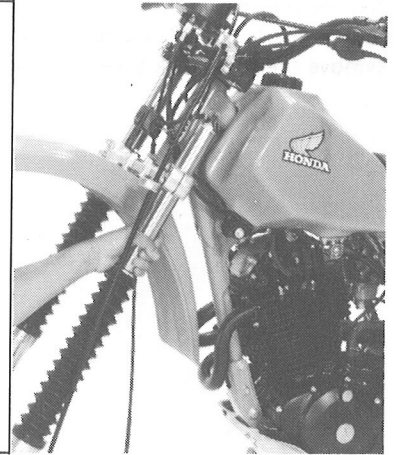
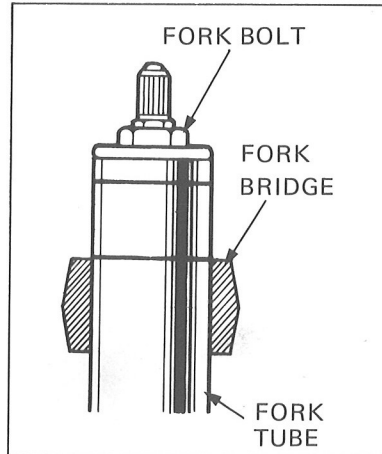

Tighten the fork top bridge pinch bolt and steering stem pinch bolts.

### TORQUE

**Fork top bridge:** 18–25 N·m (1.8–2.5 kg·m,  
Pinch bolt 13–18 ft·lb)

**Steering stem:** 18–30 N·m (1.8–3.0 kg·m,  
Pinch bolt 13–22 ft·lb)

Bring the top of each boot into contact with the steering stem and tighten the clamp.  
Install the front wheel (Page 13-11).

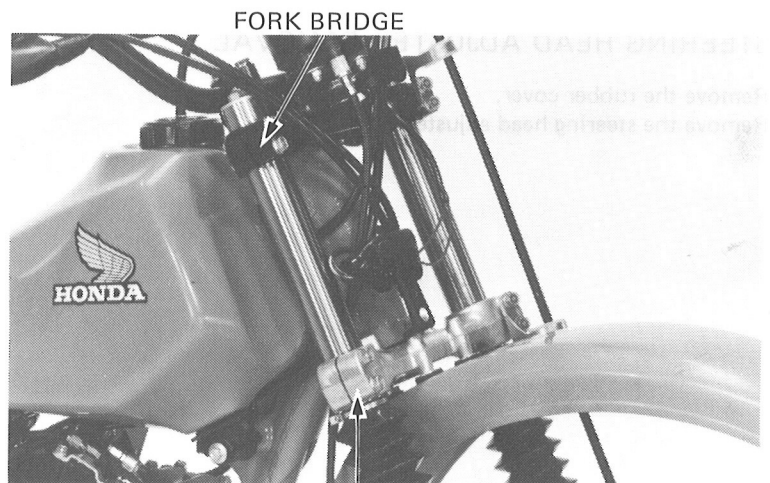

STEERING STEM

## STEERING STEM

### FORK TOP BRIDGE REMOVAL

- Remove the headlight (Page 13-3).
- Disconnect the wires at the connectors.
- Remove the following parts:
- Speedometer (Page 13-3).
- Handlebar (Page 13-4).
- Front wheel (Page 13-6).
- Front fender.
- Front fork.
- Front brake.

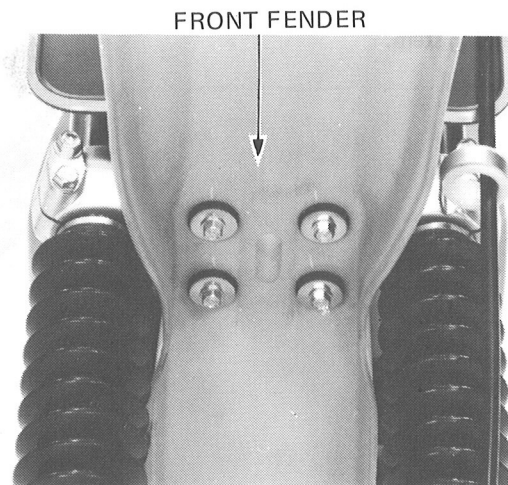

FRONT FENDER

**FRONT WHEEL  
BRAKE/SUSPENSION/STEERING**



Remove the steering stem nut.  
Loosen the fork bridge bolts and remove the bridge.  
Remove the front fork tube assemblies.

SOCKET WRENCH 30 x 32 mm

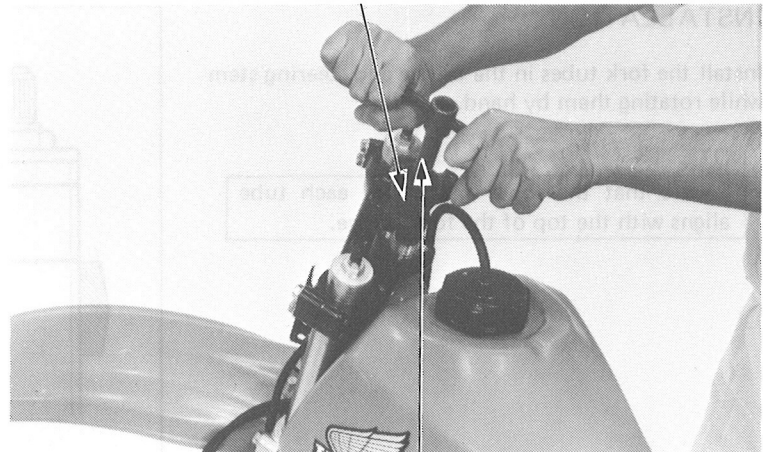

EXTENSION BAR

**STEERING HEAD ADJUSTER REMOVAL**

Remove the rubber cover.  
Remove the steering head adjuster.

EXTENSION BAR

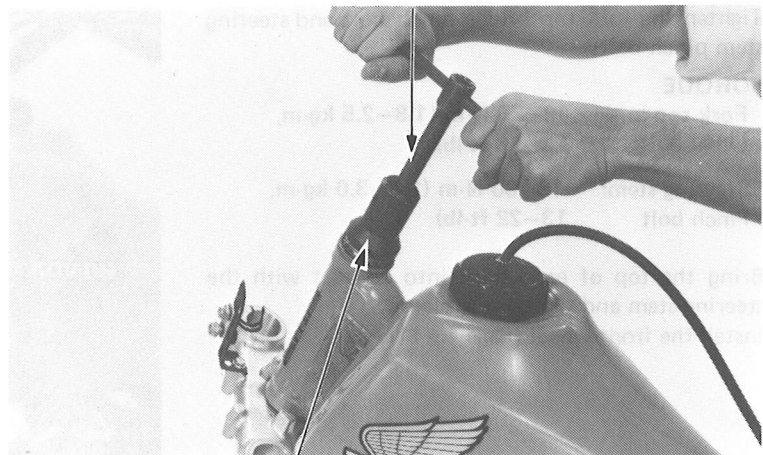

STEERING STEM SOCKET  
(07916-3710100)

Remove the steering stem.

STEERING STEM

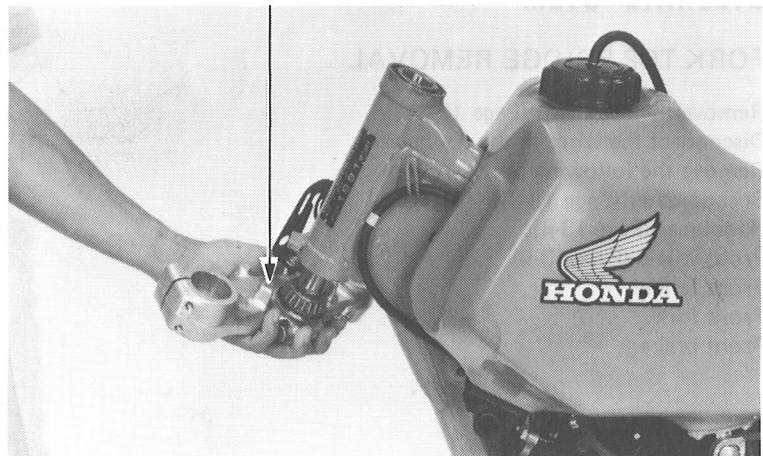



Remove the ball race with the Ball Race Remover.

BALL RACE REMOVER (07953-MA00000)



Remove the steering stem bolt.

STEERING STEM BOLT

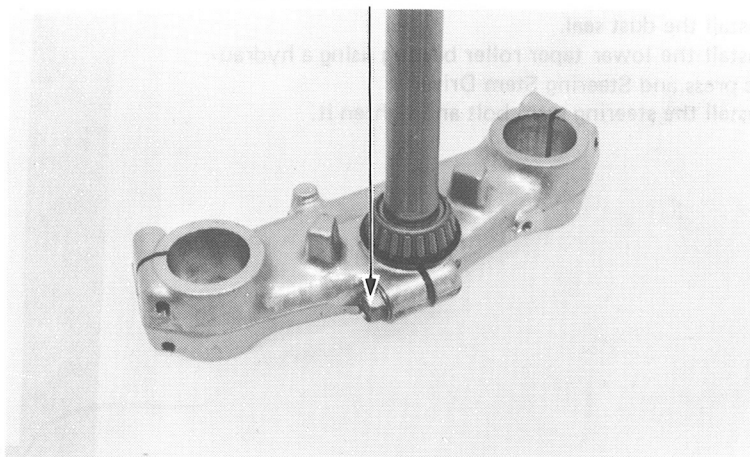

Support the steering stem on blocks in a hydraulic press as shown.  
Press out the lower taper roller bearing.

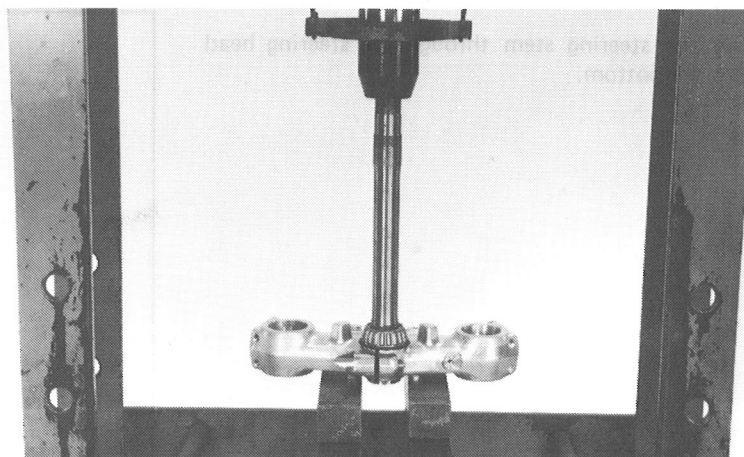

### STEERING STEM INSTALLATION

Drive in the races.

BEARING DRIVER OUTER A

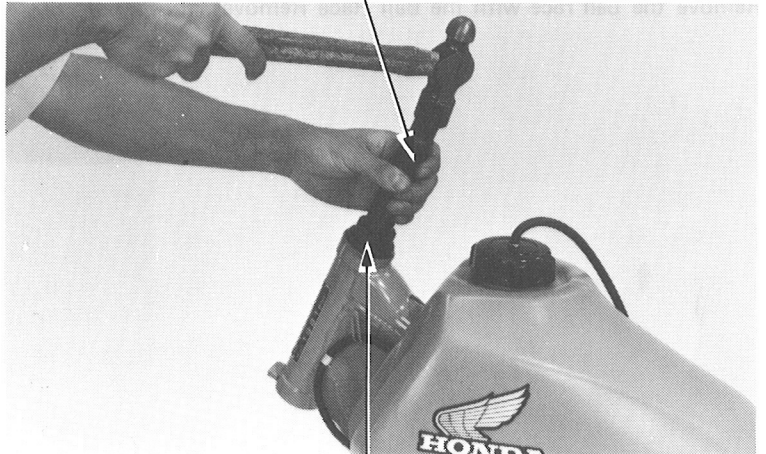

BALL RACE DRIVER (07946-4300100)

Install the dust seal.  
Install the lower taper roller bearing using a hydraulic press and Steering Stem Driver.  
Install the steering stem bolt and tighten it.

STEERING STEM DRIVER  
(07946-4300100)

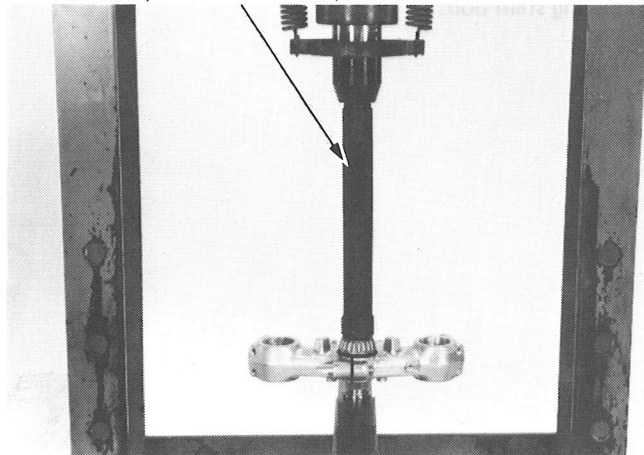

Install the upper taper roller bearing in the steering head.  
Slide the steering stem through the steering head from the bottom.

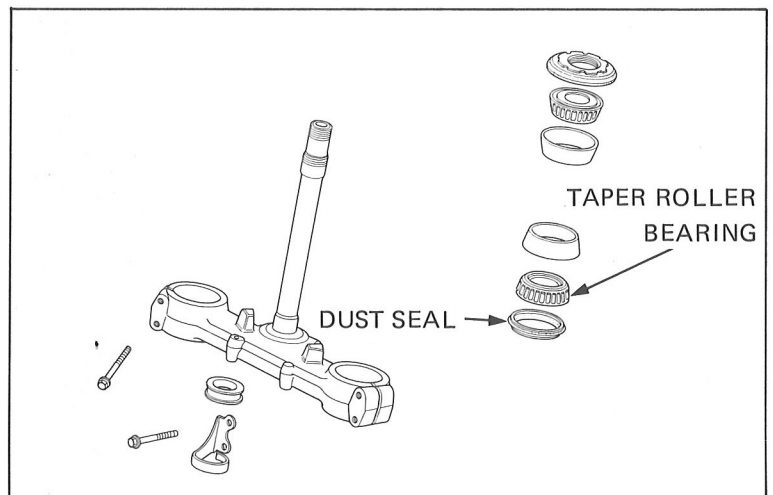



Install the steering head adjusting nut and torque with the steering stem socket.

**TORQUE: 5.5 – 6.5 N·m (0.55–0.65 kg-m,  
4 – 5 ft-lb)**

**STEERING STEM SOCKET  
(07916–3710100)**

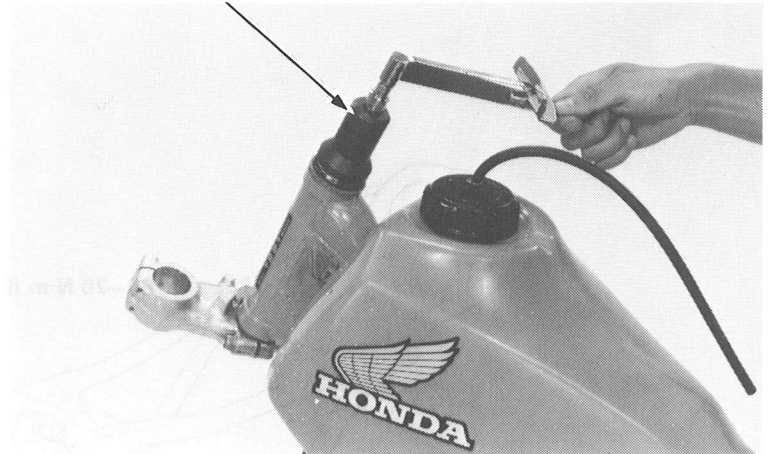

Install the fork bridge.

Tighten the steering stem nut.

**TORQUE: 80–120 N·m (8–12 kg-m, 60–90 ft-lb)**

**Install the:**

- front forks (page 13-19)
- front fender
- front wheel (page 13-11)
- handle bar. (page 13-4)

Install the speedometer and headlight (page 13-3).  
Connect the wiring.



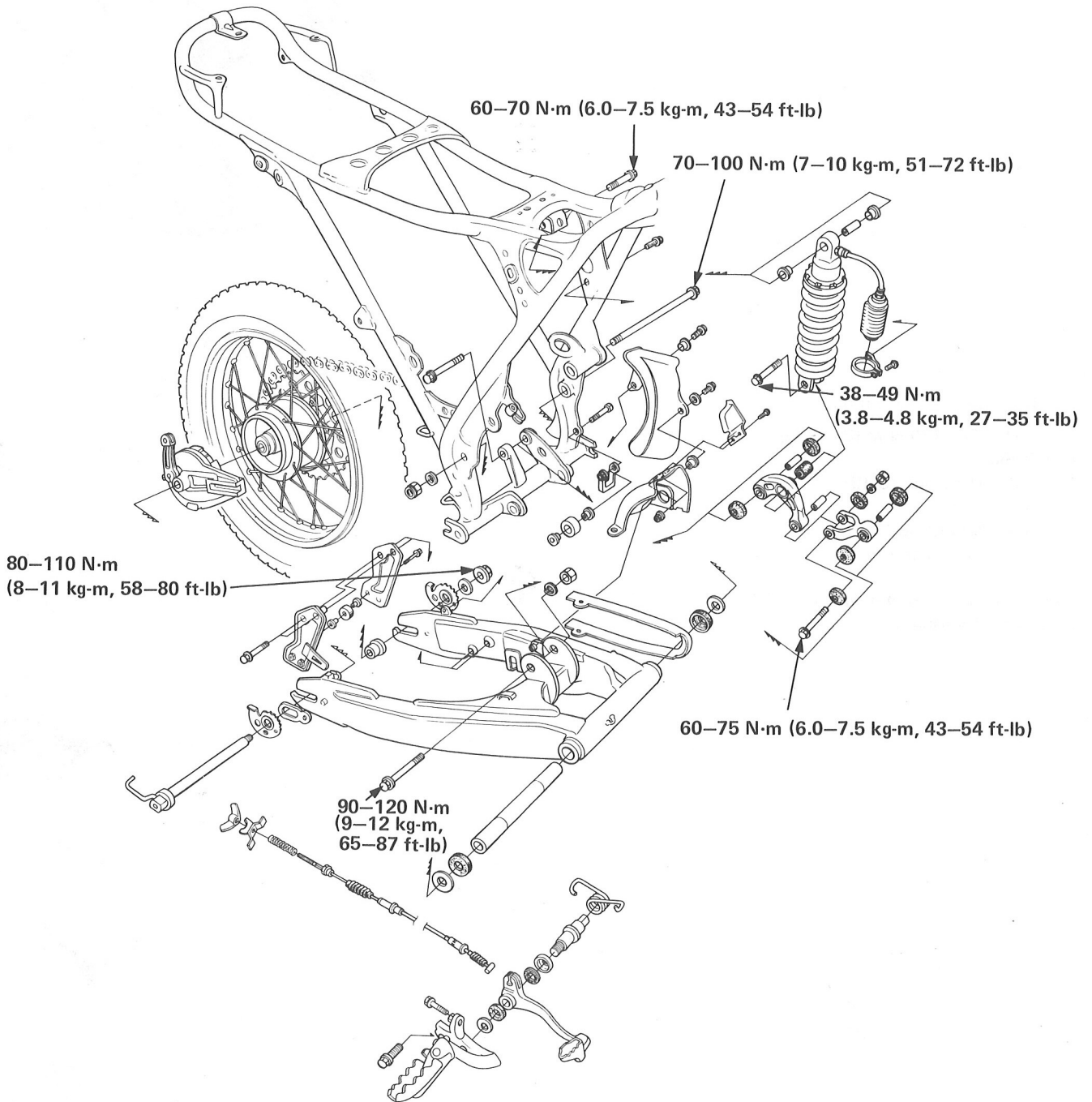



SERVICE INFORMATION	14-1
TROUBLESHOOTING	14-2
REAR WHEEL	14-3
SHOCK ABSORBERS	14-10
SWING ARM	14-12
BRAKE PEDAL	14-14

## SERVICE INFORMATION

### GENERAL INSTRUCTIONS

- A jack block is required to support the motorcycle.
- Use genuine rear suspension linkage and shock absorber pivot/mount bolts.
- Note installation direction of the bolts.

#### WARNING

- *The shock absorber is fitted with a gas-filled reservoir. Do not fill the reservoir with air.*
- *The rear shock absorber contains nitrogen under high pressure. Do not allow fire or heat near the shock absorber.*
- *Be sure to release nitrogen gas pressure before disposal.*
- *Brake dust may contain asbestos which can be harmful to your health. Do not use compressed air to clean brake drums or brake panels. Use a vacuum with a sealed dust collector. Wear a protective face mask and thoroughly wash your hands when finished.*

### TOOLS

#### SPECIAL

Swingarm bearing remover	M967-0390-XXXXX (U.S.A. only)
Bearing remover set	07936-3710000
(Bearing remover	07936-3710600)
(Bearing remover handle	07936-3710100)
(Bearing remover weight	07936-3710200)
Needle bearing driver	07946-KA50000

#### COMMON

Bearing driver outer, 37 x 40 mm	07746-0010200
Bearing driver outer, 42 x 47 mm	07746-0010300
Bearing driver handle outer A	07749-0010000
Driver pilot, 17 mm	07746-0040400
Retainer wrench body	07710-0010400
Retainer wrench A	07710-0010100

#### OPTIONAL

Pin spanner A	89201-KA4-810
Pin spanner B	89202-KA4-810

### TORQUE VALUES

Rear shock absorber (upper)	60 - 75 N·m (6 - 8 kg-m, 43 - 54 ft-lb)
(lower)	38 - 48 N·m (4 - 5 kg-m, 28 - 35 ft-lb)
Rear suspension linkage	
Tension arm	90 - 120 N·m (9 - 12 kg-m, 65 - 87 ft-lb)
Tension rod (Front)	60 - 75 N·m (6 - 8 kg-m, 43 - 54 ft-lb)
(Rear)	60 - 75 N·m (6 - 8 kg-m, 43 - 54 ft-lb)
Spokes	2.5 - 5.0 N·m (0.25 - 0.5 kg-m, 1.8 - 3.6 ft-lb)
Final driven sprocket	28 - 34 N·m (2.8 - 3.4 kg-m, 20 - 25 ft-lb)
Rear axle nut	80 - 110 N·m (8 - 11 kg-m, 58 - 80 ft-lb)
Swingarm pivot bolt	70 - 100 N·m (7 - 10 kg-m, 51 - 72 ft-lb)
Left foot peg bolt	70 - 100 N·m (7 - 10 kg-m, 51 - 72 ft-lb)
Brake pedal pivot bolt	70 - 100 N·m (7 - 10 kg-m, 51 - 72 ft-lb)
Rim lock	10 - 15 N·m (1.0 - 1.5 kg-m, 7 - 11 ft-lb)



**SPECIFICATIONS**

ITEM		STANDARD	SERVICE LIMIT
Rear shock absorber spring free length		222.6 mm (8.76 in)	219 mm (8.6 in)
Rear wheel runout	Radial	—————	2.0 mm (0.10 in)
	Axial	—————	2.0 mm (0.10 in)
Rear axle runout		—————	0.2 mm (0.01 in)
Rear brake drum I.D.		130 mm (5.21 in)	131.0 mm (5.20 in)
Rear brake		4.0 mm (0.16 in)	2.0 mm (0.10 in)
Rear brake shoe thickness		4.0 mm (0.16 in)	2.0 mm (0.10 in)
Rear suspension damper compression		28 – 38 kg (62 – 84 lbs)	23 kg (51 lbs)

**TROUBLESHOOTING**

**Wobble or vibration in motorcycle**

1. Bent rim
2. Loose wheel bearing
3. Loose or bent spokes
4. Damaged tire
5. Axle not tightened properly
6. Swingarm pivot bearing worn
7. Chain adjusters not adjusted equally

**Soft suspension**

1. Weak spring
2. Improper rear suspension damping or spring preload adjusting

**Hard suspension**

1. Improper rear suspension damping or spring preload adjusting
2. Spring thrust joint binding
3. Bent shock absorber rod
4. Swingarm pivot bearings damaged

**Suspension noise**

1. Faulty rear damper
2. Loose fasteners
3. Worn suspension linkage pivot bushings

**Poor brake performance**

1. Improper brake adjustment
2. Worn brake shoes
3. Brake linings oily, greasy or dirty
4. Worn brake cam
5. Worn brake drum
6. Brake arm serrations improperly engaged
7. Brake shoes worn at cam contact area





## REAR WHEEL

### REAR WHEEL REMOVAL

Raise the rear wheel off the ground by placing a jack or block under the engine.  
Pull the brake arm pin holder forward and disconnect the brake cable from the brake arm.

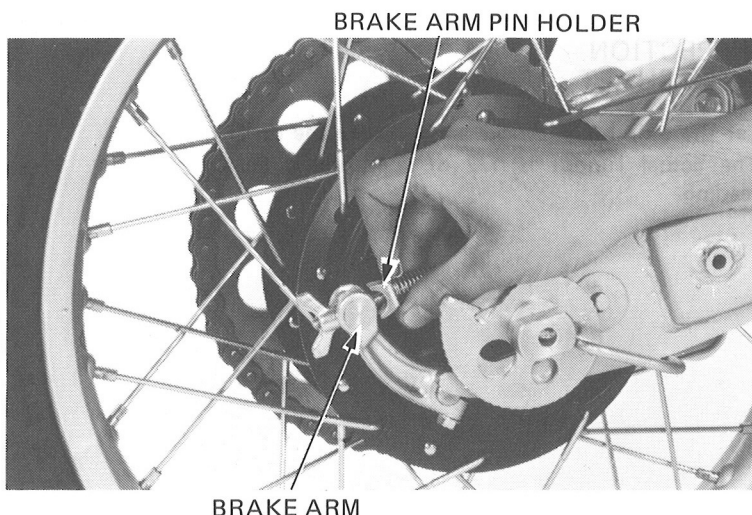

Loosen the rear axle nut.  
Turn both adjusters so the rear wheel can be moved all the way forward for maximum drive chain slack.  
Move the rear wheel forward and "hook" the adjusters over the stopper pins on the swingarm.

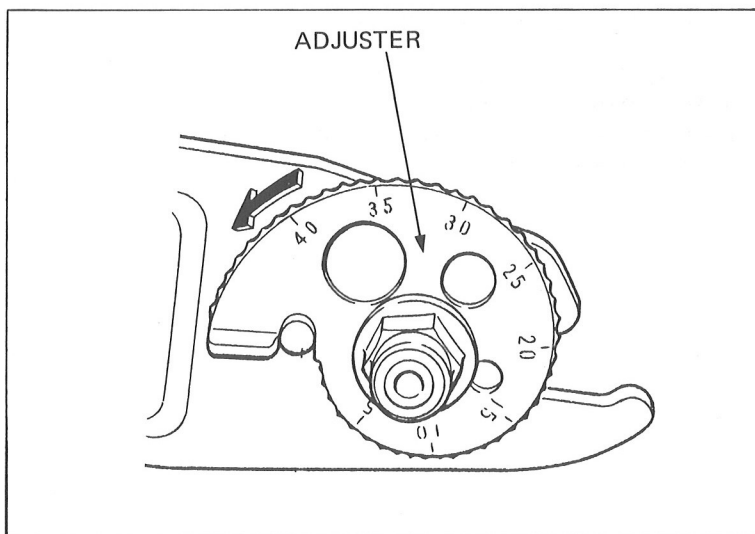

Derail the drive chain from the drive sprocket.  
Remove the stopper plate from the pin on the swingarm's right side.  
Remove the rear wheel with the rear axle.

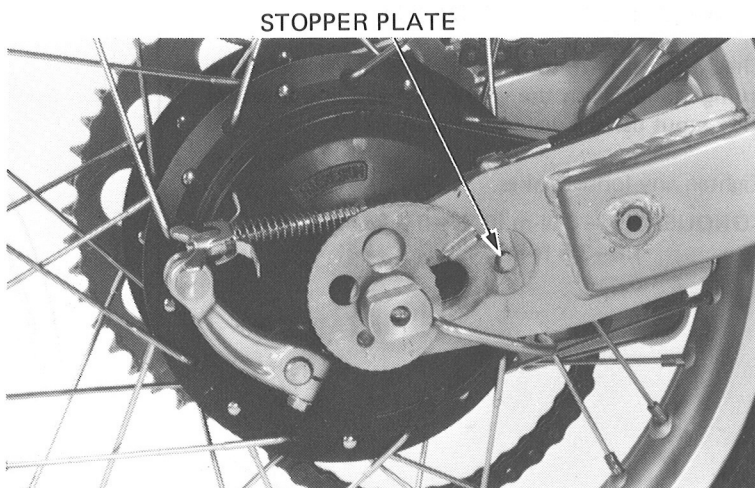

**INSPECTION  
AXLE SHAFT**

Set the axle on V blocks and measure the runout. The actual runout is 1/2 of the total indicator reading.

**SERVICE LIMIT: 0.2 mm (0.01 in)**

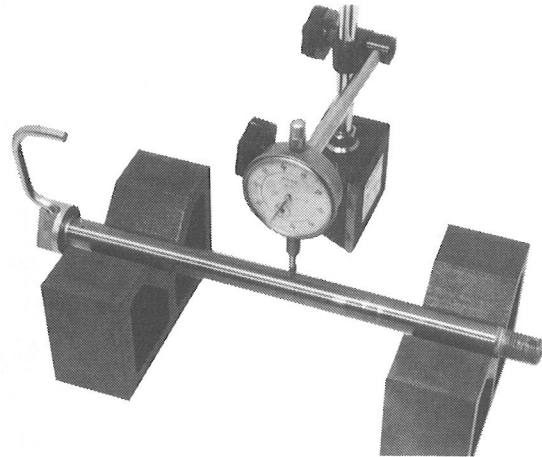

**REAR WHEEL BEARING PLAY**

Check the wheel bearing play by placing the wheel in a truing stand and spinning the wheel by hand. Replace the bearings with new ones if they are noisy or have excessive play.

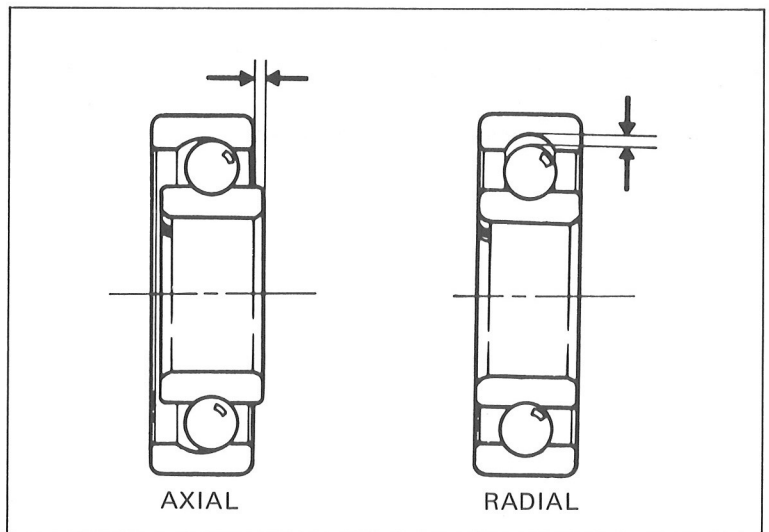

**REAR WHEEL RIM RUNOUT**

Check the rim runout by placing the wheel on a truing stand. Turn the wheel by hand and measure the runout using a dial indicator.

Tighten any loose spokes.

**TORQUE: 2,5 – 5 N·m (0.25–0.5 kg·m,  
1.8–3.5 ft·lb)**

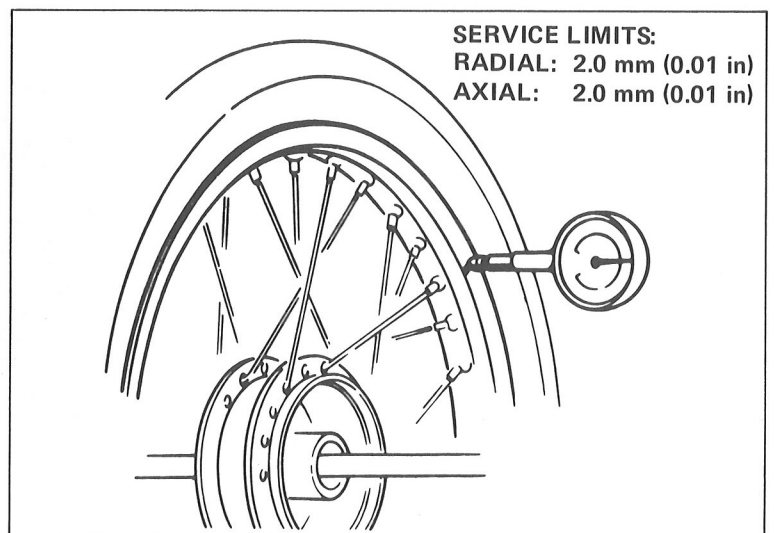



### REAR BRAKE DRUM I.D.

Measure the rear brake drum I.D.

**SERVICE LIMIT: 131.0 mm (5.16 in)**

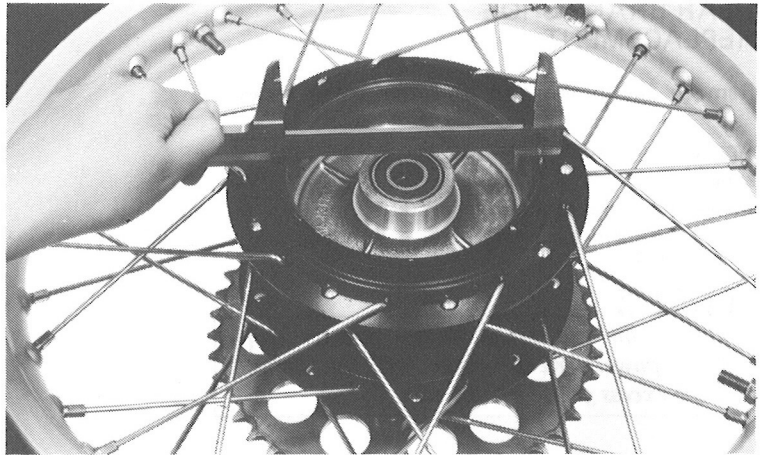

### FINAL DRIVEN SPROCKET

Check the condition of the final driven sprocket teeth.

Replace the sprocket if worn or damaged.

#### NOTE

The drive chain and drive sprocket must also be inspected if the driven sprocket is worn or damaged.

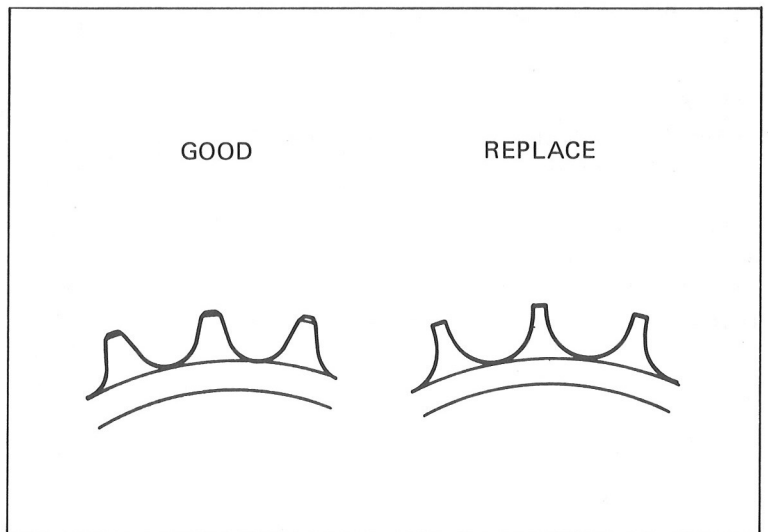

### BRAKE LINING

Measure the rear brake lining thickness.

**SERVICE LIMIT: 2.0 mm (0.10 in)**

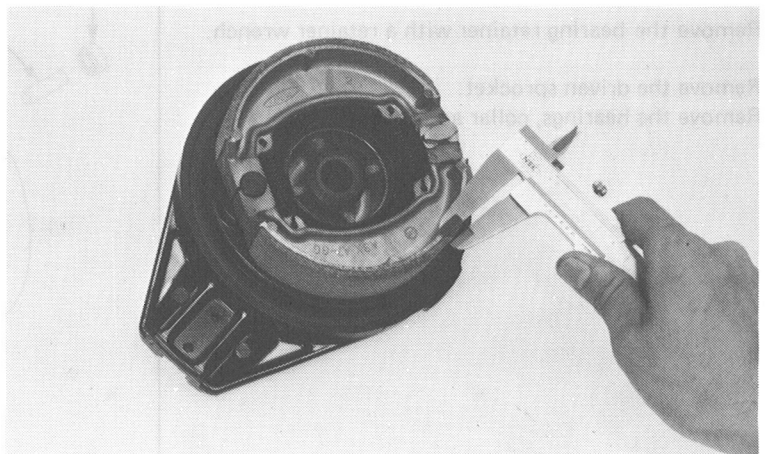



### REAR BRAKE SHOE REPLACEMENT

Remove the brake arm and the brake shoes.

Apply grease to the face of the brake cam and anchor pin.

Install the brake cam and new brake shoes.

Install the springs.

**WARNING**

*Grease on the brake linings reduces stopping power. Keep grease off the linings. Wipe excess grease off the cam.*

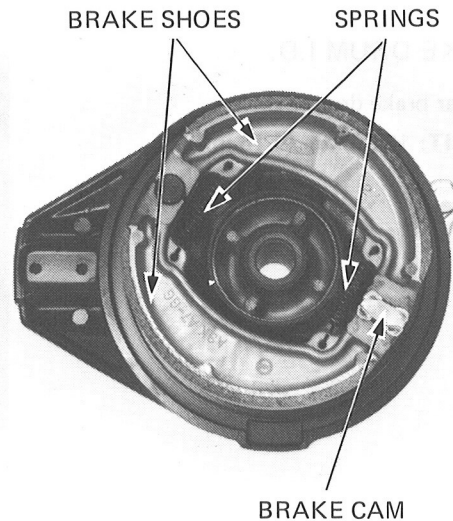

Install the wear indicator plate onto the brake cam.

**NOTE**

Align the indicator tab with the cutout in the brake camshaft.

Install the brake arm aligning the punch mark with the cam punch mark.

Tighten the brake arm bolt.

**TORQUE: 8–12 N·m (0.8–1.2 kg·m, 6–9 ft·lb)**

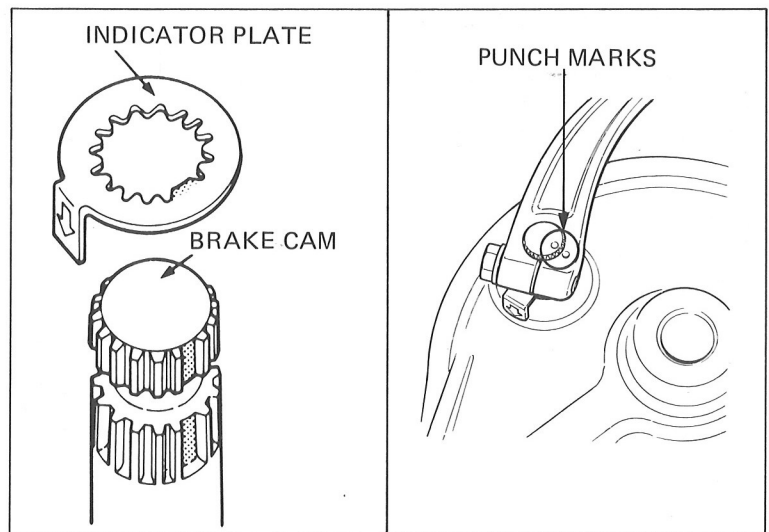

### REAR WHEEL DISASSEMBLY

Remove the bearing retainer with a retainer wrench.

Remove the driven sprocket.

Remove the bearings, collar and O-ring.

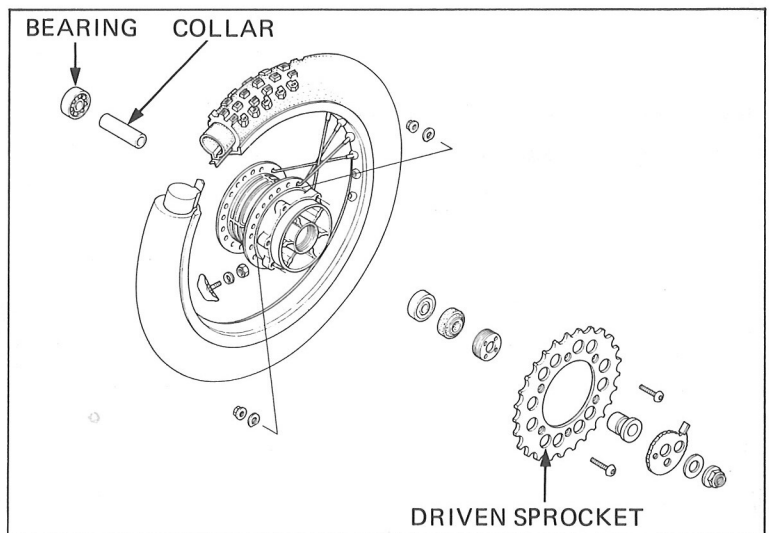



### REAR WHEEL ASSEMBLY

Install the final driven sprocket and tighten the sprocket bolts.

**TORQUE VALUE: 27–33 N·m (2.7–3.3 kg·m, 20–24 ft·lb)**

Pack the bearing cavities with grease.  
Install the right and left wheel bearings in the wheel hub.

Install the bearings with the sealed end facing out.

**WARNING**

*Grease on the brake linings reduces stopping power. Keep grease off the linings.*

Drive the oil seal into position in the bearing retainer.

Apply grease to the oil seal.

Grease and install the bearing retainer with the retainer wrench and body.

BEARING DRIVER HANDLE OUTER A

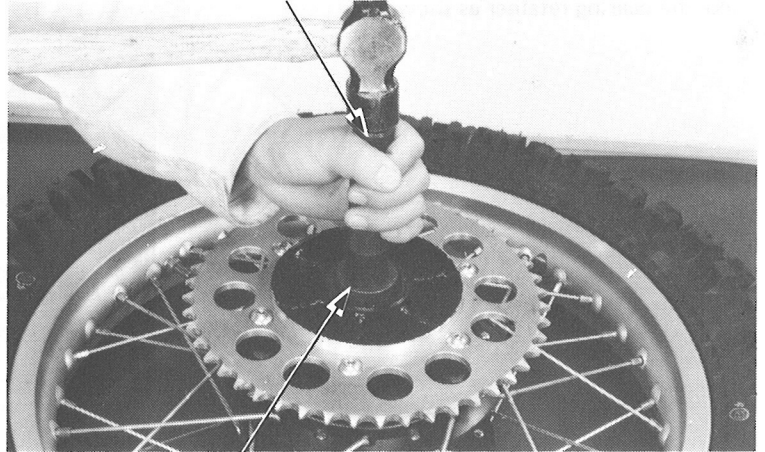

BEARING DRIVER OUTER 42 x 47 mm  
BEARING DRIVER PILOT 17 mm

BEARING DRIVER HANDLE A

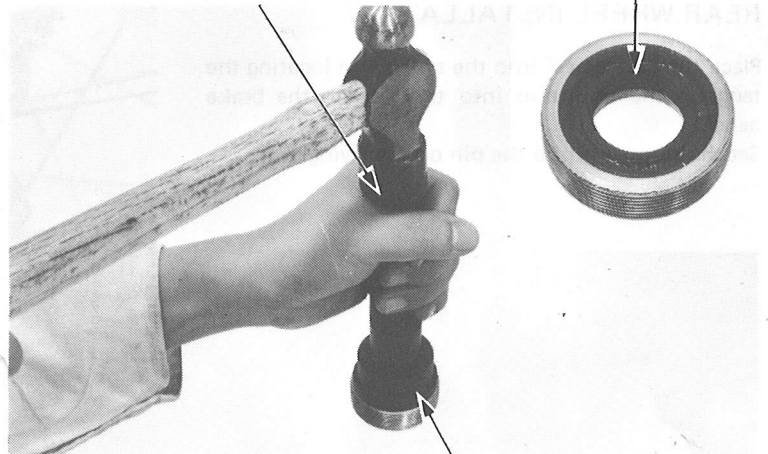

BEARING DRIVER OUTER 37 x 40 mm

RETAINER WRENCH

RETAINER WRENCH BODY

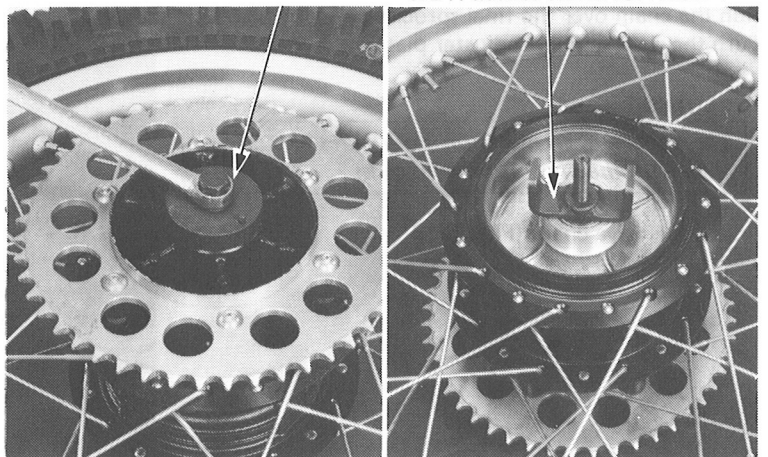





Stake the bearing retainer as shown.

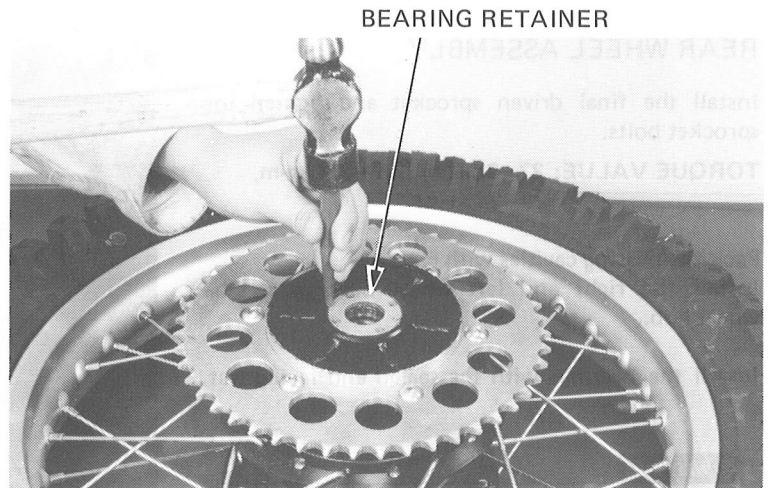

### REAR WHEEL INSTALLATION

Place the rear wheel into the swing arm locating the tang on the swingarm into the slot on the brake panel.  
Set the stopper pin to the pin on the swingarm.

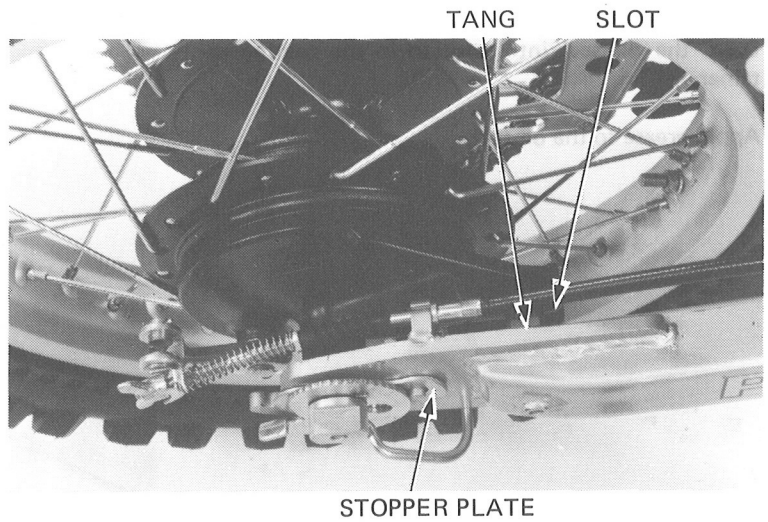

Run the chain over the final sprocket.  
Turn the right and left adjuster plates.

**CAUTION:**

*The same index mark on both sides should align with the pins on the swingarm.*

Adjust the drive chain (Page 3-13).

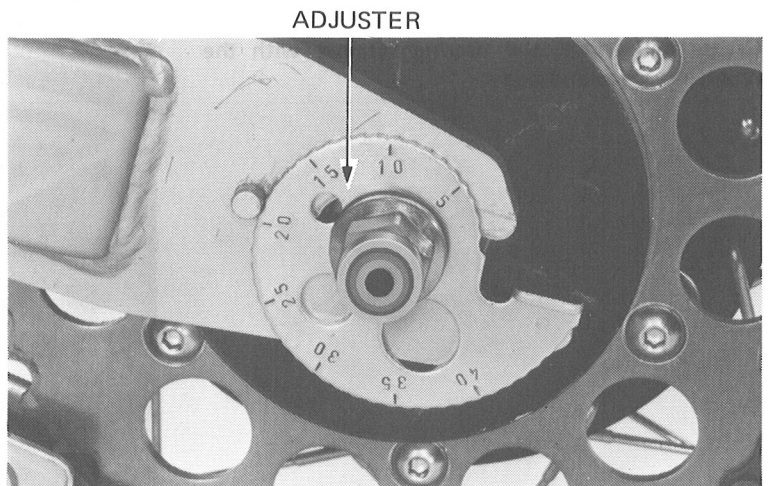



Tighten the axle nut.

**TORQUE: 80–110 N·m**  
**(8–11 kg·m, 58–80 ft·lb)**

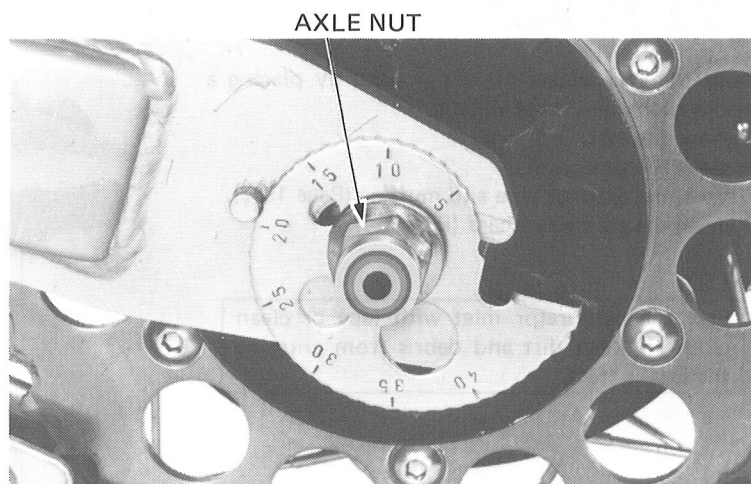

Pull the brake arm pin holder and brake arm forward and insert the brake cable into the pin. Adjust the brake pedal free play. (Page 3-16)

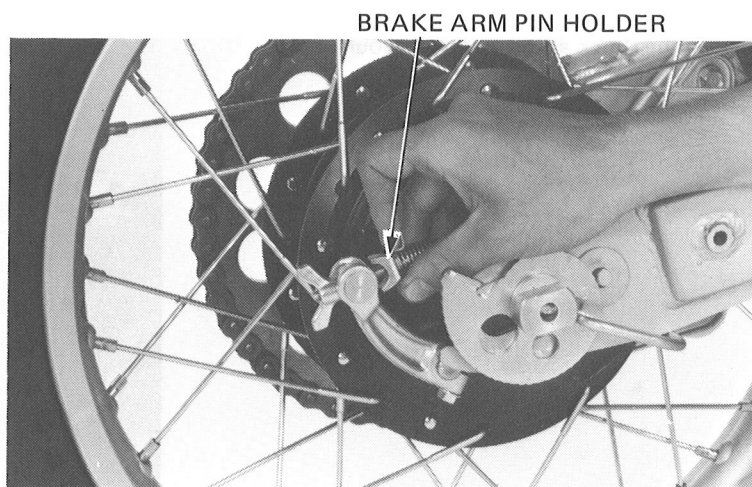

## SHOCK ABSORBER

Raise the rear wheel off the ground by placing a jack or block under the engine.

Remove the seat.

Remove the side covers.

Remove the exhaust pipe and muffler (Page 15-1).

Remove the air cleaner case (Page 4-4).

### NOTE

Seal the carburetor inlet with tape or clean cloth to keep dirt and debris from entering the intake tract.

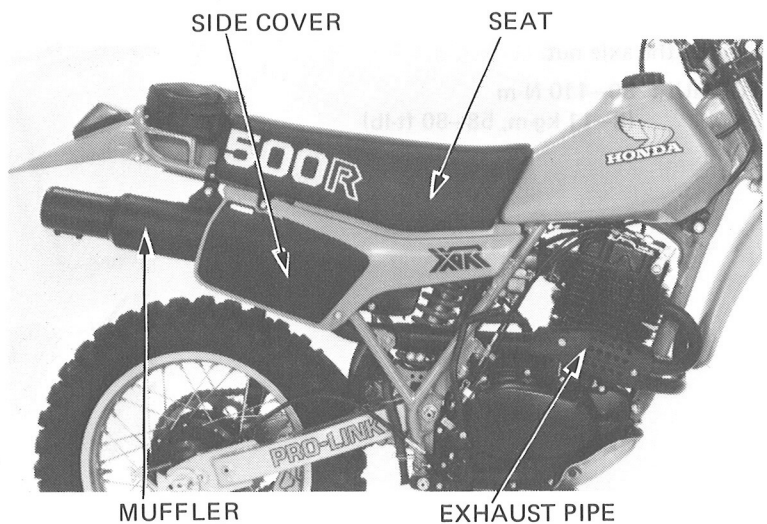

Remove the shock absorber upper mount bolt.

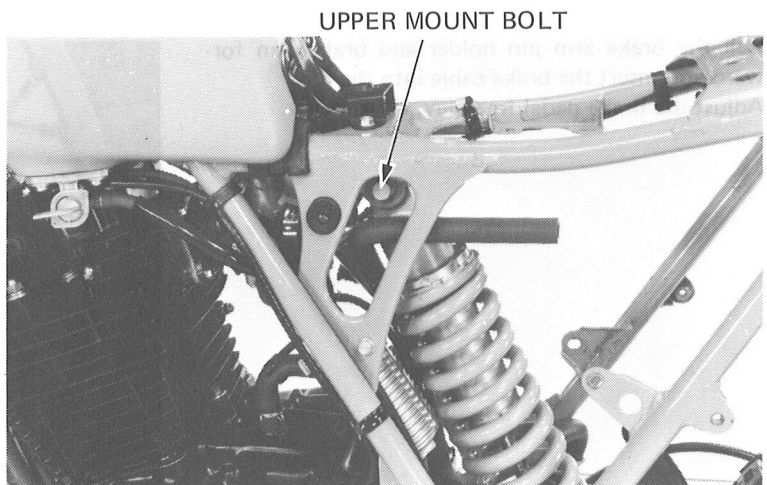

Remove the bolt attaching the shock link to the frame.

### CAUTION:

*Do not remove the bolt connecting the shock arm to the shock link.*

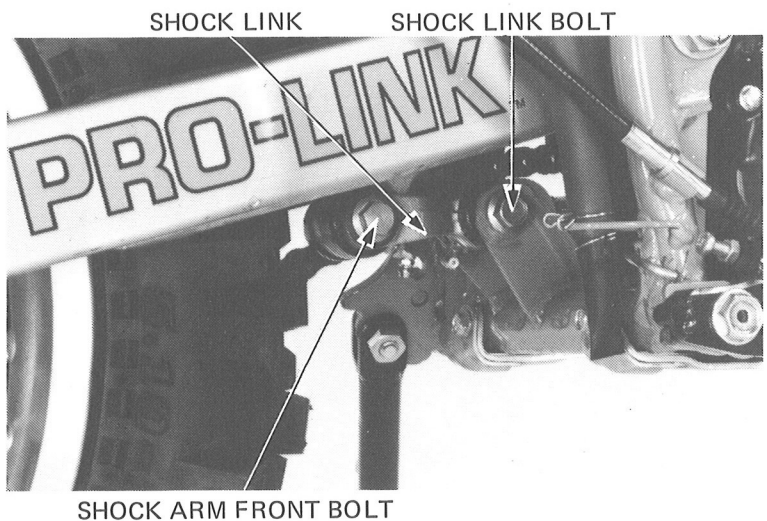





Loosen the shock absorber lower bolt,  
Move the rear shock absorber back as shown.  
Lift up the rear wheel with a jack or block under  
the wheel until the lower mount bolt is clear of the  
swingarm.

**NOTE**

Do not let the shock absorber touch the  
frame brackets when lifting up the rear wheel.  
This may cause damage to the shock absorber  
thread.

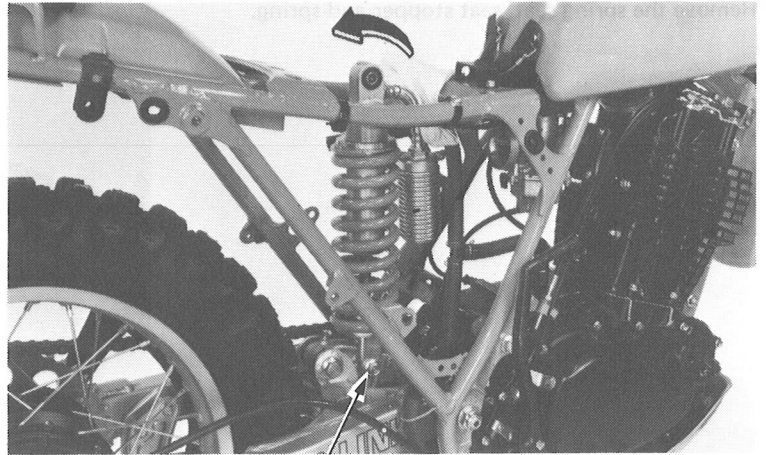

LOWER MOUNT BOLT

Remove the rear shock absorber lower bolt and  
remove the shock absorber.

**NOTE**

Do not let the rear wheel fall.

LOWER MOUNT BOLT TENSION ARM



**DISASSEMBLY**

Hold the upper part of the shock in a vise with  
soft jaws or a shop towel.  
Loosen the lock nut and adjusting nut.

**CAUTION:**

*Be careful not to damage the hose connection  
in a vise.*

**NOTE**

The pin spanners are optional tools.

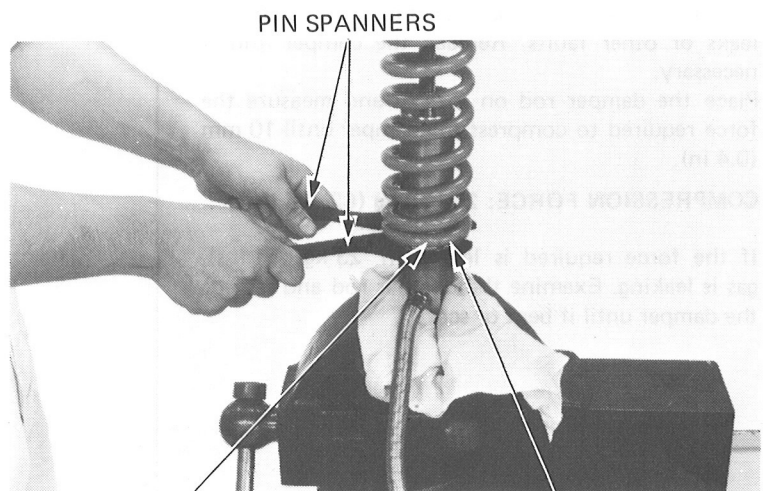

PIN SPANNERS

LOCK NUT

ADJUSTING NUT

Remove the spring seat, seat stopper and spring.

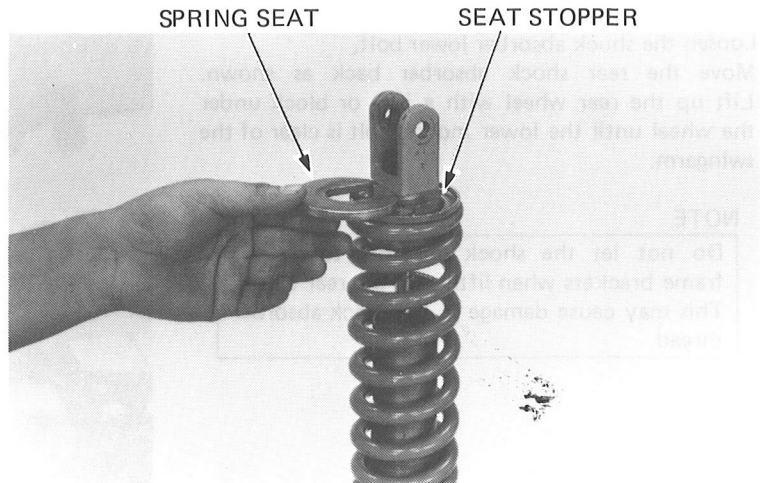

### SHOCK ABSORBER SPRING INSPECTION

Measure the spring free length.

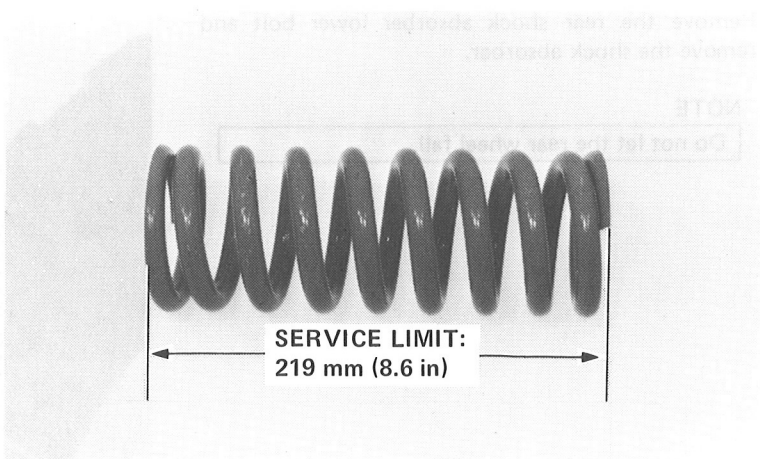

Visually inspect the damper unit for dents, oil leaks or other faults. Replace the damper unit if necessary.

Place the damper rod on a scale and measure the force required to compress the damper until 10 mm (0.4 in).

**COMPRESSION FORCE: 28–38 kg (62–84 lbs)**

If the force required is less than 23 kg (51 lbs), gas is leaking. Examine the damper rod and replace the damper until if bent or scored.

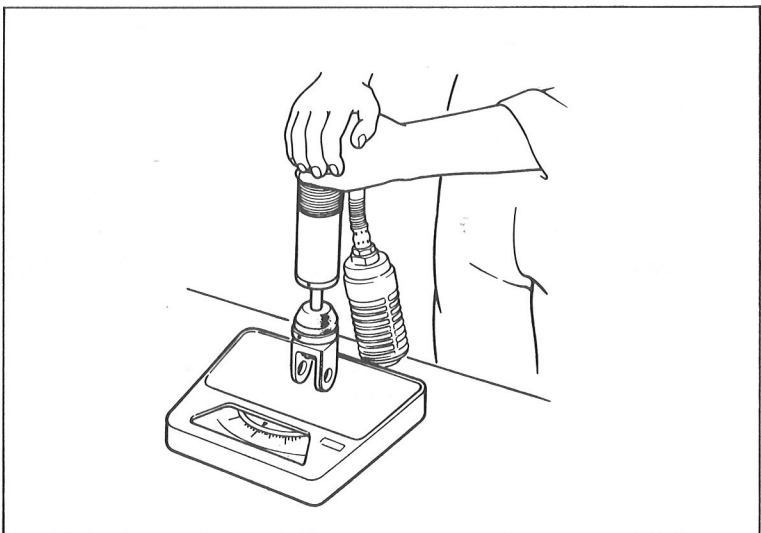



Remove the cap from the reservoir.

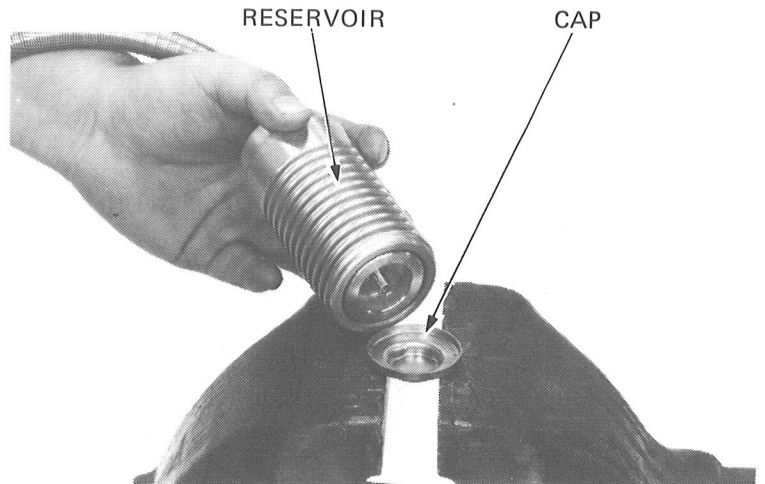

Depress the schrader valve to release the nitrogen from the reservoir.

**CAUTION:**

- *Be sure to release nitrogen gas pressure before disassembly.*
- *Point the valve away from you.*

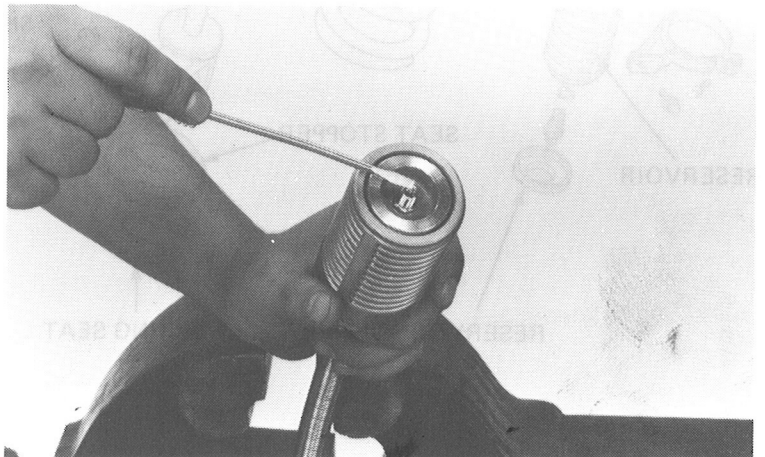

Remove the lock nuts.  
Separate the reservoir, hose and damper complete.  
Remove the spring lock nut and adjusting nut.

**CAUTION:**

*Do not disassemble the damper unit.*

Drain the oil from the reservoir, hose and damper unit.

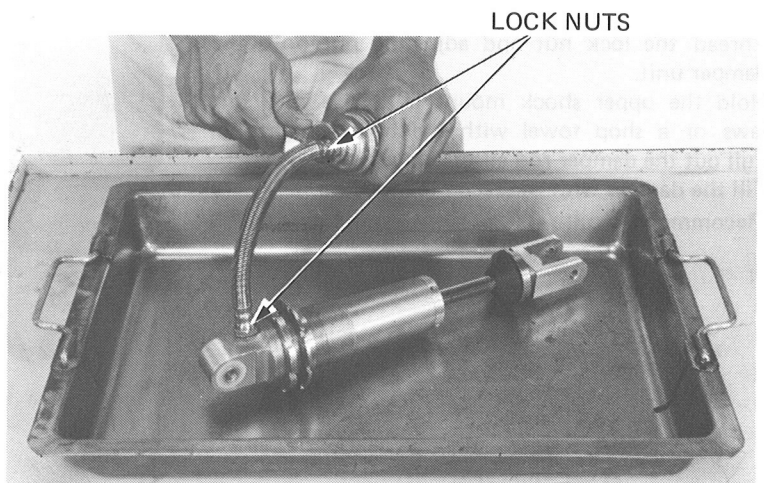

SHOCK ABSORBER ASSEMBLY

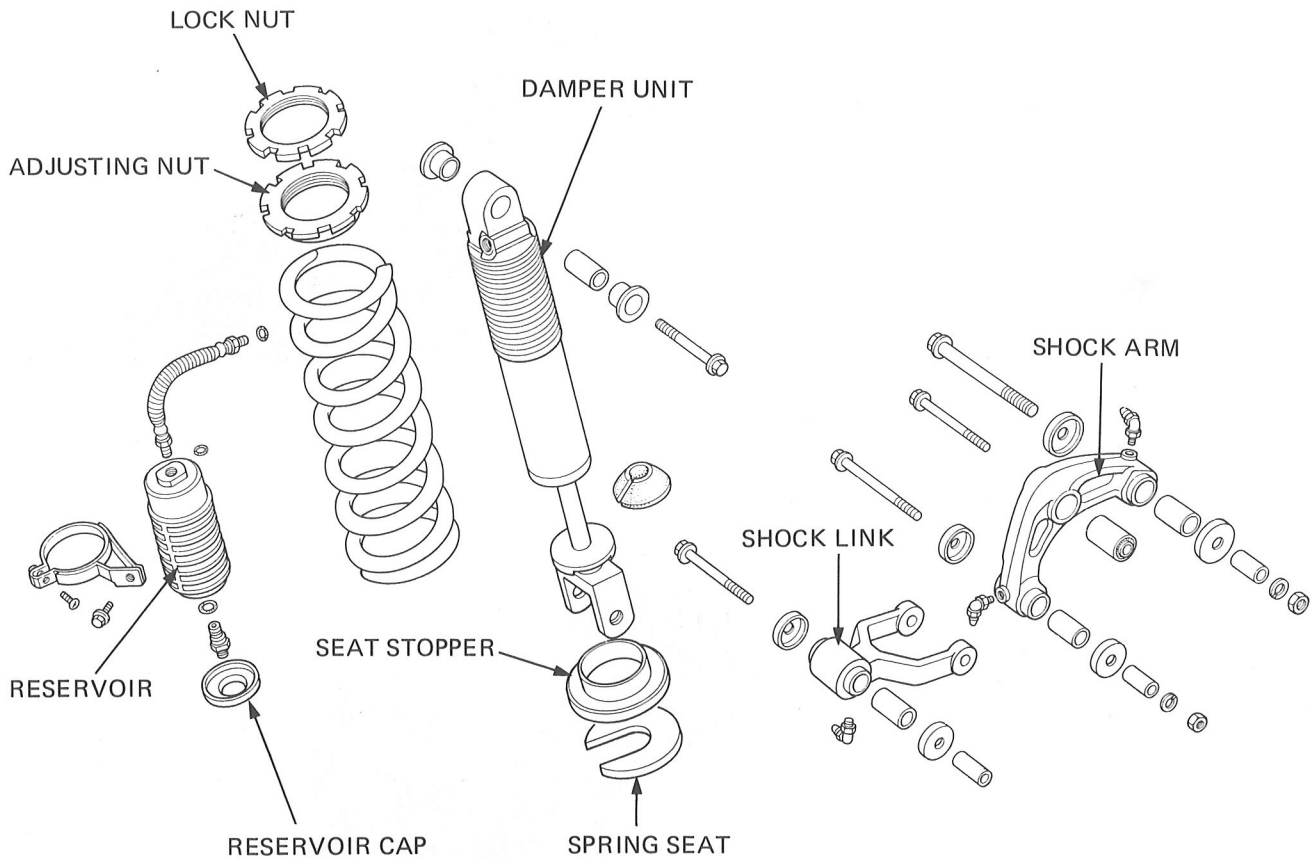

Thread the lock nut and adjusting nut onto the damper unit.

Hold the upper shock mount in a vise with soft jaws or a shop towel with the hole straight up. Pull out the damper rod all the way.

Fill the damper with the recommended oil.

**Recommended oil: ATF**

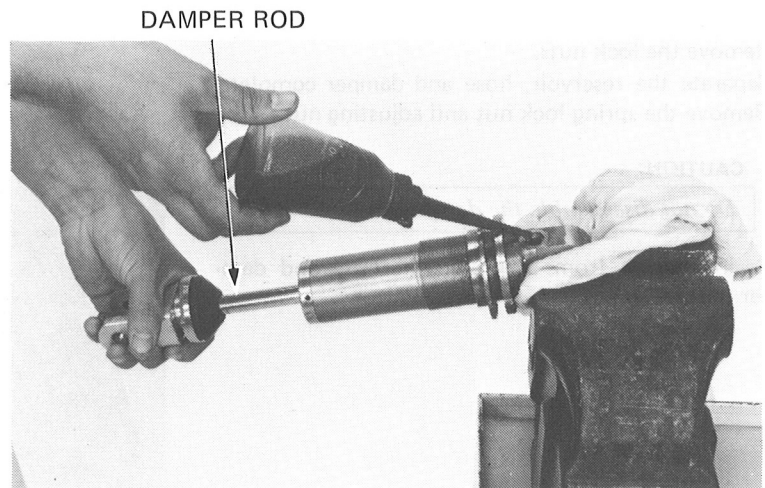





Bleed air from the damper by moving the damper rod back and forth several times slowly.  
Fill the damper with ATF as required.

**NOTE**

The damper should be as free of air as possible.

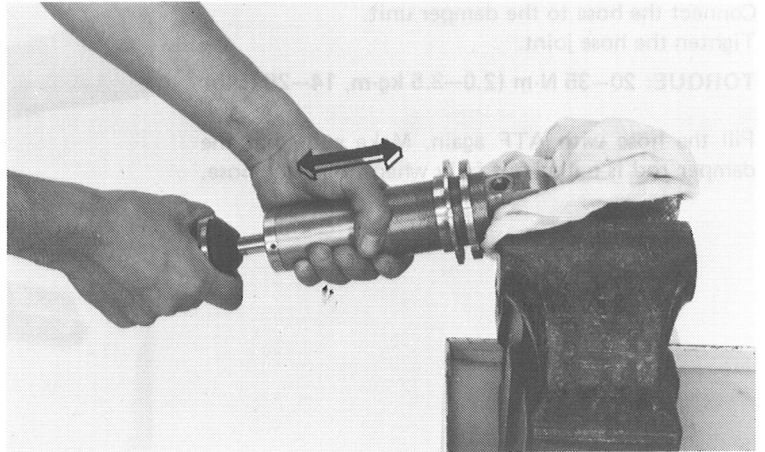

Fill the reservoir with ATF.

**NOTE**

Make sure that there is no gas pressure in the reservoir.

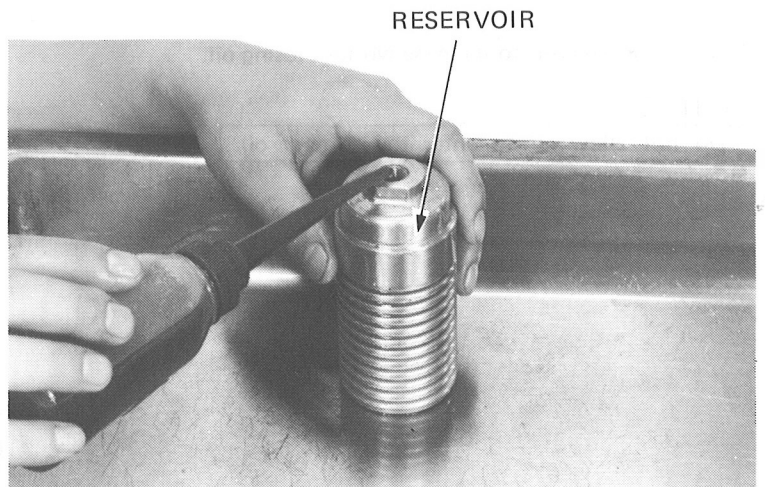

Install the O-rings on the hose joints.  
Fill the hose with ATF.

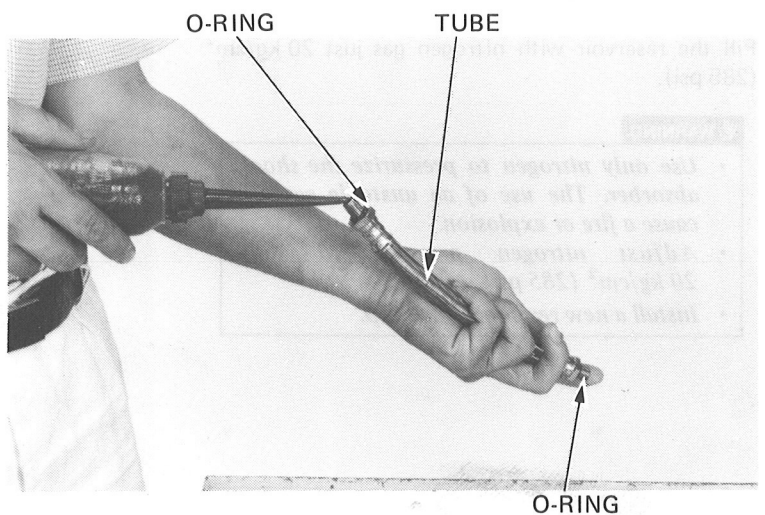

REAR WHEEL  
BRAKE/SUSPENSION



Connect the hose to the damper unit.  
Tighten the hose joint.

**TORQUE: 20–35 N·m (2.0–3.5 kg·m, 14–25 ft·lb)**

Fill the hose with ATF again. Make sure that the damper rod is pulled out fully when filling the hose.

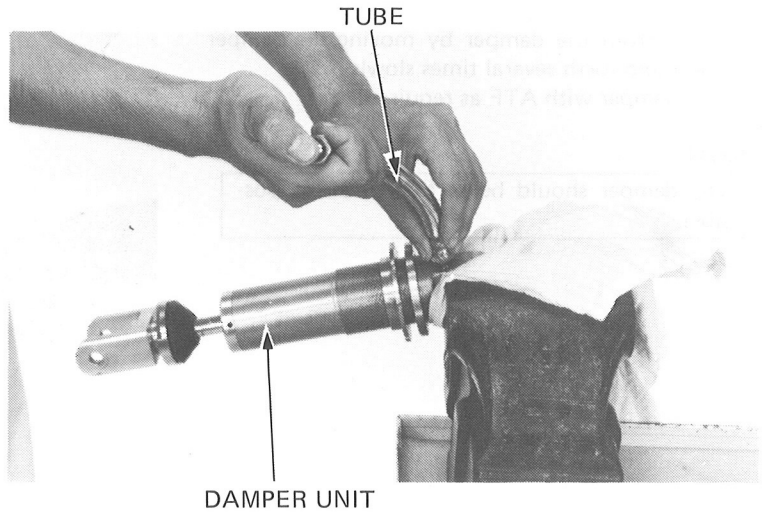

Connect the reservoir to the hose without losing oil.

**NOTE**

Do not allow air to enter the damper oil.

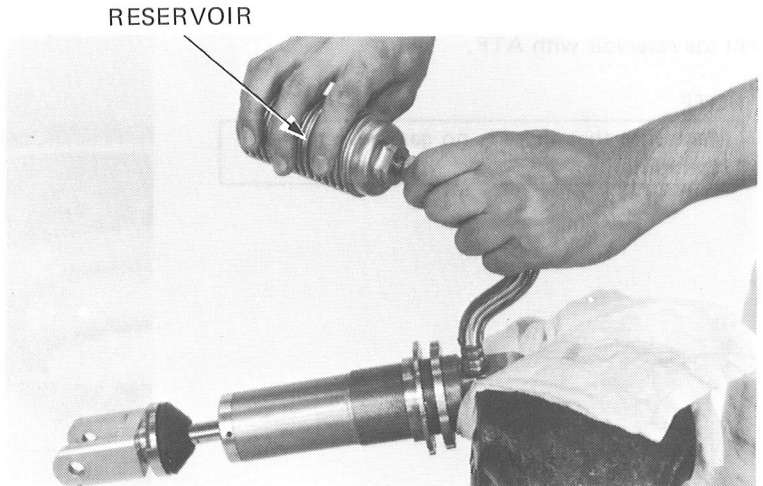

Fill the reservoir with nitrogen gas just 20 kg/cm<sup>2</sup> (285 psi).

**WARNING**

- Use only nitrogen to pressurize the shock absorber. The use of an unstable gas can cause a fire or explosion.
- Adjust nitrogen pressure to only 20 kg/cm<sup>2</sup> (285 psi).
- Install a new reservoir valve cap.

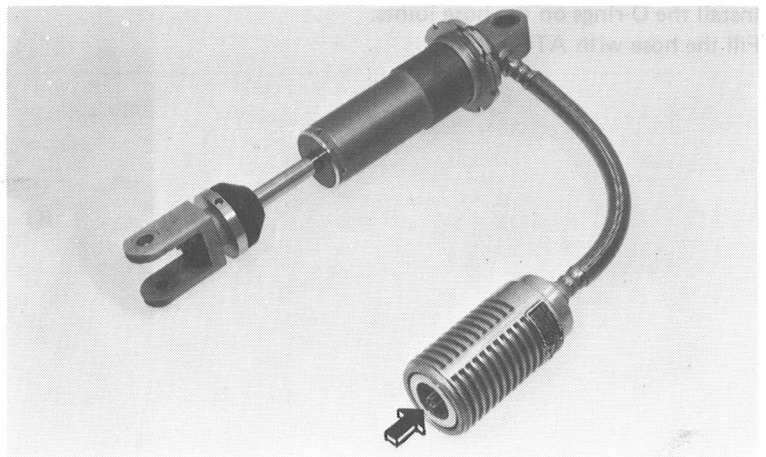





Install the spring, spring seat and seat stopper.  
Position the upper and lower shock absorber mounts so as to allow holes in the mounts to face in the same direction.  
Be sure the adjusting mark should face opposite to the reservoir hose.

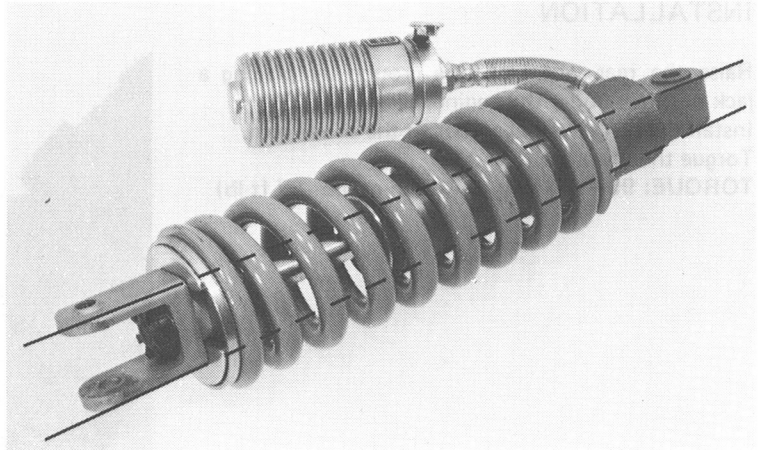

Measure the spring's length.  
Turn the adjusting nut to obtain the standard spring length.

**STANDARD SPRING LENGTH: 212.6 mm (8.4 in)**

**NOTE**

One turn equals 1.5 mm (0.06 in)

To increase spring preload; tighten the adjusting nut to shorten the spring length up to 5 mm (1/4 in) and tighten the lock nut.

**CAUTION:**

*Do not shorten the spring more than 5 mm (1/4 in), or damage to the spring could result.*

To reduce spring preload; loosen the adjusting nut to increase spring length 5 mm (1/4 in) and tighten the lock nut.

**CAUTION:**

*Do not ride the motorcycle without the spring having preload. Loss of rider control could result.*

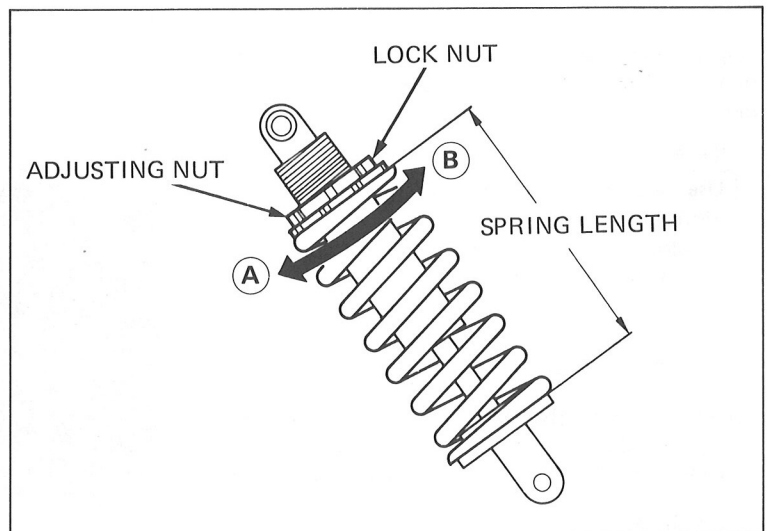

A: SHORTEN THE SPRING LENGTH  
B: INCREASE THE SPRING LENGTH



### INSTALLATION

Raise the rear wheel off the ground by placing a jack or block under the engine.

Install the rear shock absorber to the shock arm.

Torque the lower bolt.

**TORQUE: 90–120 N·m (9–12 kg·m, 65–87 ft·lb)**

LOWER MOUNT BOLT

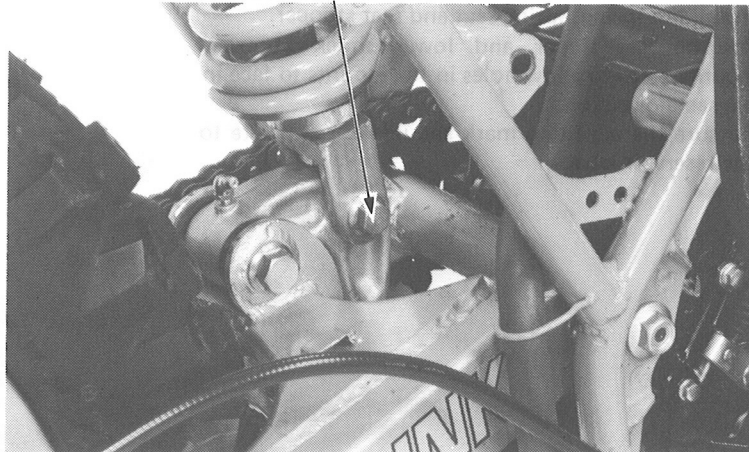

Apply molybdenum disulfide (MoS<sub>2</sub>) paste (containing more than 45% of MoS<sub>2</sub>) to the upper mount bushings.

#### NOTE

Use MoS<sub>2</sub> paste (containing more than 45% of MoS<sub>2</sub>) as follows:

- Molykote® G-n Paste manufactured by Dow Corning U.S.A.
- Rocol Paste manufactured by Sumico Lubricant Co., LTD., Japan.
- Other lubricants of equivalent quality.

Attach the shock absorber to the frame and torque the upper bolt.

**TORQUE: 60–75 N·m (6.0–7.5 kg·m, 43–54 ft·lb)**

#### WARNING

*Use only the correct bolts. Do not substitute other fasteners. Since they may not have adequate strength and may fail during operation.*

Attach the shock link to the frame and torque the bolt.

**TORQUE: 60–75 N·m (6.0–7.5 kg·m, 43–54 ft·lb)**

UPPER MOUNT BOLT

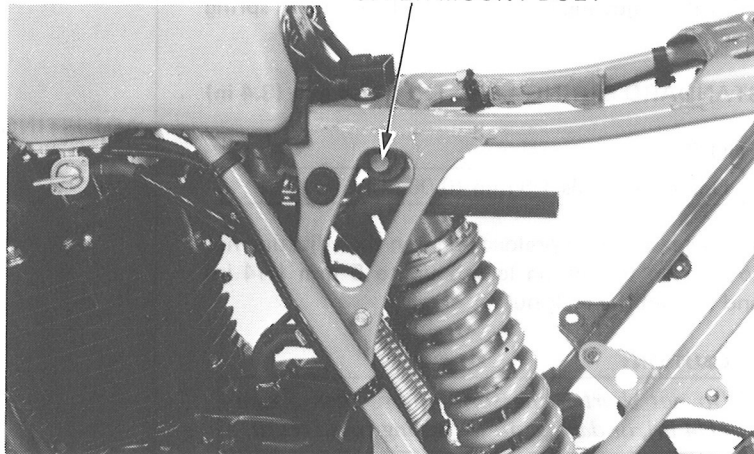

SHOCK LINK





Install the following:  
air cleaner case  
exhaust pipe  
muffler  
side covers  
seat

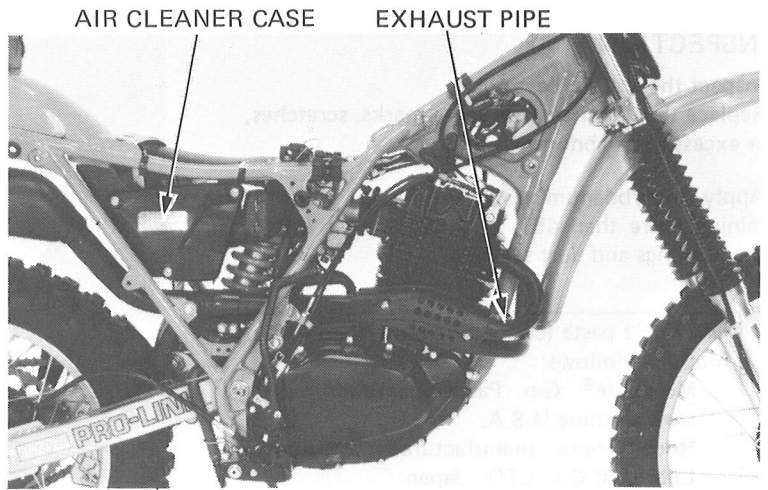

## SWING ARM

### SWING ARM REMOVAL

Raise the rear wheel off the ground with a jack or block under the engine.  
Remove the rear wheel (Page 14-3).  
Remove the rear shock absorber (Page 14-10).  
Remove the swing arm pivot bolt.

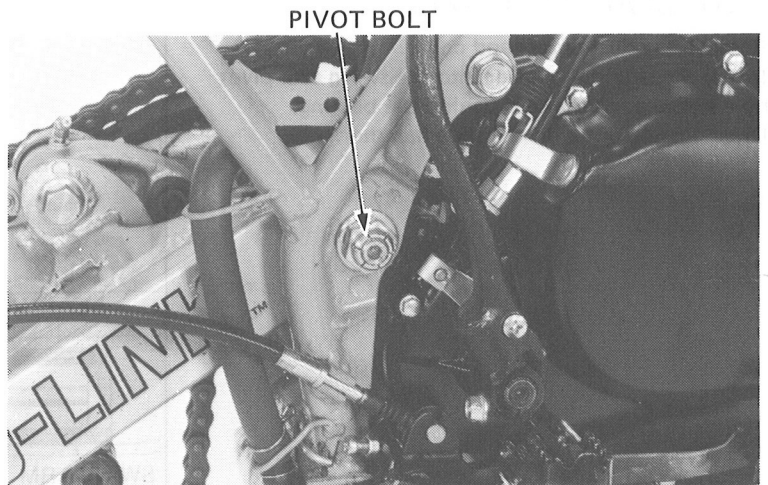

### DISASSEMBLY

Remove the shock arm from the swing arm.  
Remove the chain guide, chain case and mud guard.

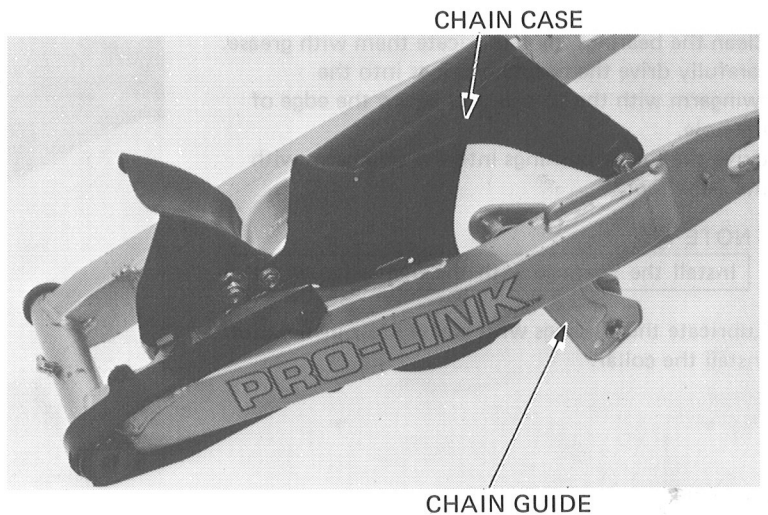

## REAR WHEEL BRAKE/SUSPENSION



# HONDA XR500R

### INSPECTION

Inspect the collars, bearings.  
Replace them if they have score marks, scratches,  
or excessive or abnormal wear.

Apply molybdenum disulfide (MoS<sub>2</sub>) paste (con-  
taining more than 45% of MoS<sub>2</sub>) to the insides of  
the bushings and dust seal lips.

#### NOTE

Use MoS<sub>2</sub> paste (containing more than 45% of  
MoS<sub>2</sub>) as follows:

- Molykote® G-n Paste manufactured by  
Dow Corning U.S.A.
- Rocol Paste manufactured by Sumico  
Lubricant Co., LTD., Japan.
- Other lubricants of equivalent quality.

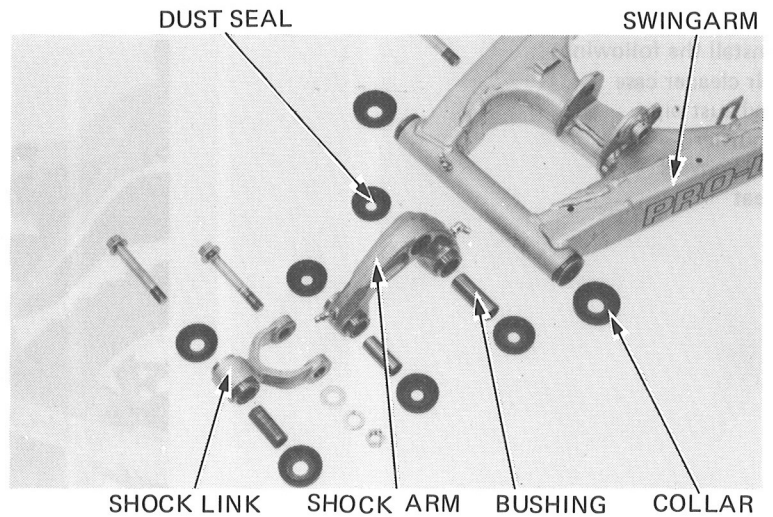

### PIVOT BEARING REPLACEMENT

Remove the dust covers and collar.  
Install the bearing remover into the swing arm pivot  
hole and expand the tool behind the bearing.  
Drive bearing out with the slide hammer.

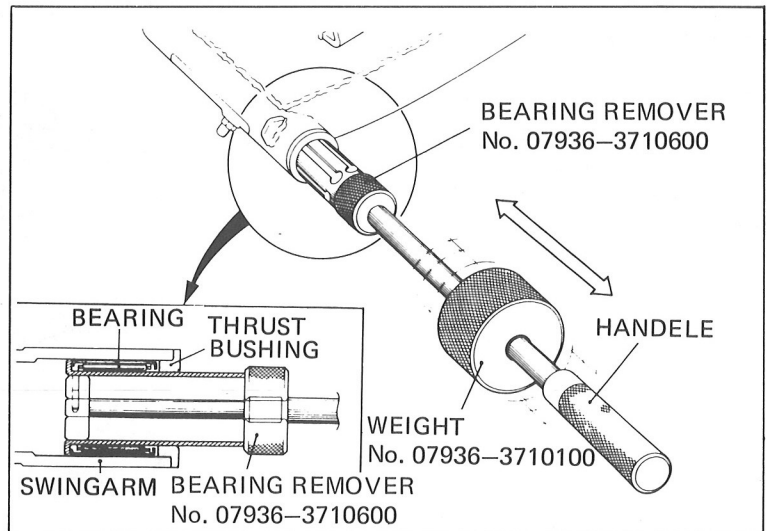

Clean the bearings, then lubricate them with grease.  
carefully drive the needle bearings into the  
swingarm with the special tool below the edge of  
the hole.  
Drive the thrust bushings into the swingarm with  
the same tool.

#### NOTE

Install the bearings with the marks facing out

Lubricate the bearings with grease after installation.  
Install the collar.

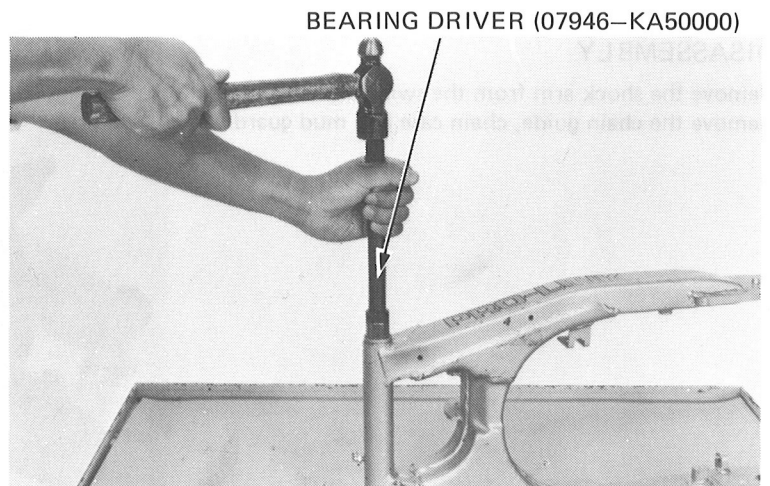





### SWING ARM ASSEMBLY

Assemble the drive chain guide roller plates.  
Install them onto the swingarm.  
Tighten the bolts securely.

#### NOTE

Install the guide roller to the rear hole in the chain guide roller plates.

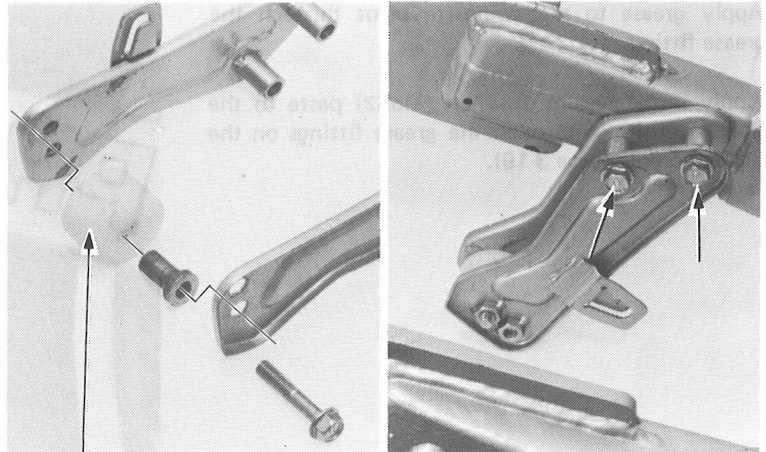

GUIDE ROLLER

Install the chain case and mudguard.  
Install the chain slider.

Install the shock link to the shock arm.

**TORQUE: 60–75 N·m (6.0–7.0 kg-m, 43–54 ft-lb)**

Install the shock arm onto the swingarm.

**TORQUE: 90–120 N·m (9–12 kg-m, 65–87 ft-lb)**

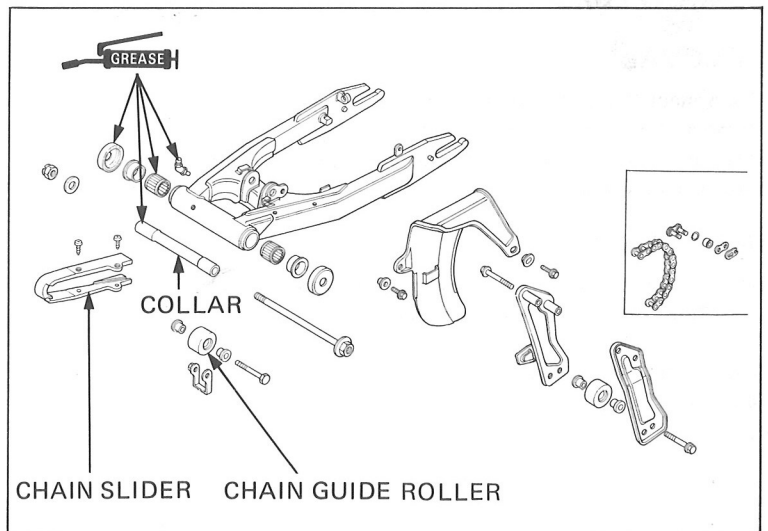

### SWINGARM INSTALLATION

Install the swingarm and torque the pivot bolt.

**TORQUE: 70–100 N·m  
(7–10 kg-m, 50.6–72.2 ft-lb)**

Install the shock absorber (Page 14-18).  
Connect the rear brake cable.  
Adjust the rear brake pedal free play (Page 3-16).

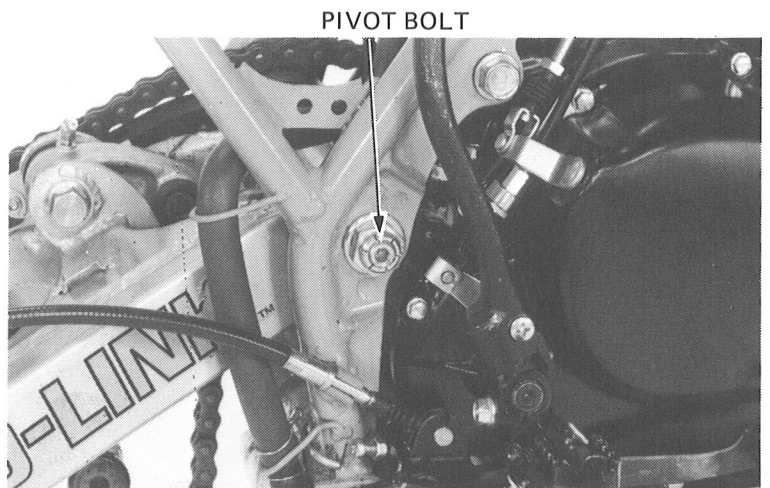



## REAR WHEEL BRAKE/SUSPENSION



**HONDA**  
**XR500R**

Apply grease to the swingarm pivot through the grease fitting.

Apply molybdenum disulfide (MoS<sub>2</sub>) paste to the linkage bushings through the grease fittings on the linkage pivots (page 3-19).

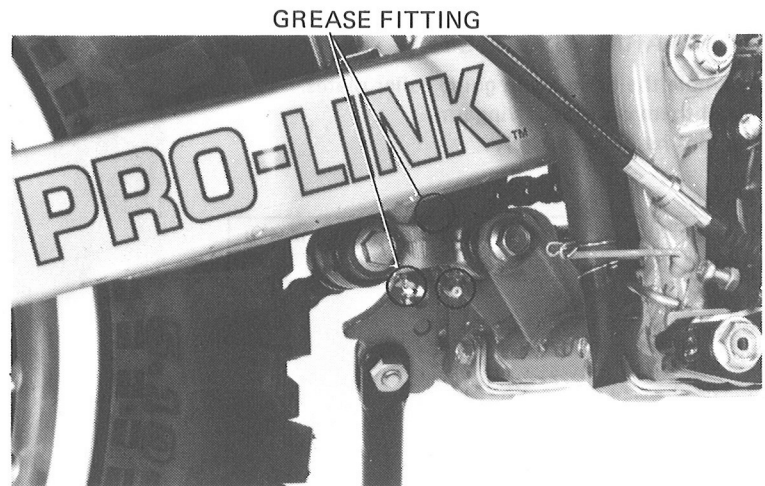

## BRAKE PEDAL

### REMOVAL

Disconnect the brake pedal spring.  
Remove the right foot peg mounting bolt.  
Disconnect the brake cable and remove the right foot peg and brake pedal.

### INSTALLATION

When assembling, apply grease to the brake pedal pivot bolt, dust cover and dust seals.

Install the brake pedal in the reverse order of removal.

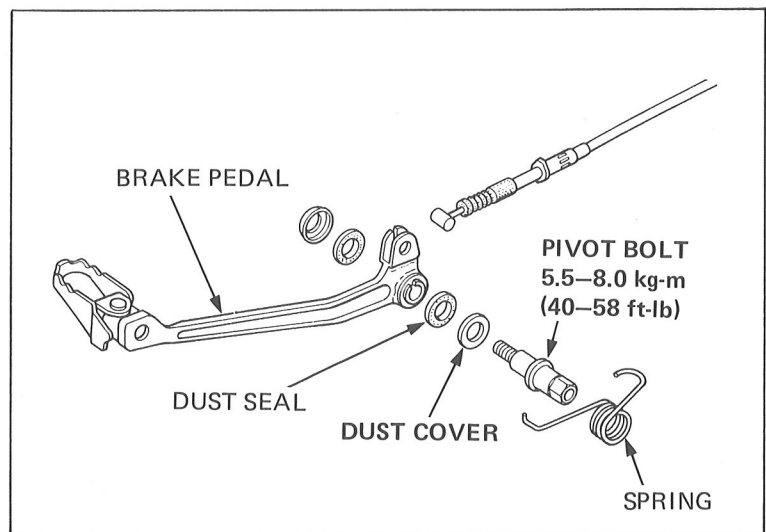



## REAR FENDER

### REMOVAL

Remove the seat.  
Remove the tool bag.

Disconnect the taillight wire and remove the taillight.

Remove rear fenders A and B.

### INSTALLATION

Install the fenders in the reverse order of removal.

#### NOTE

Before installing the seat, check that the rear fender is set on the frame cross member properly.

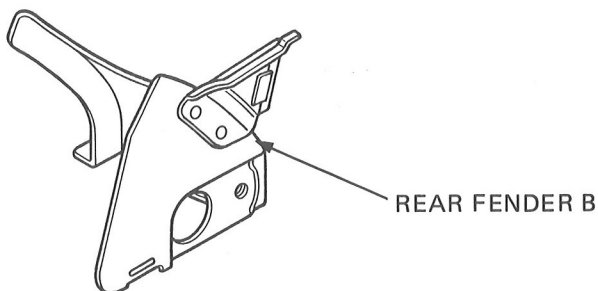
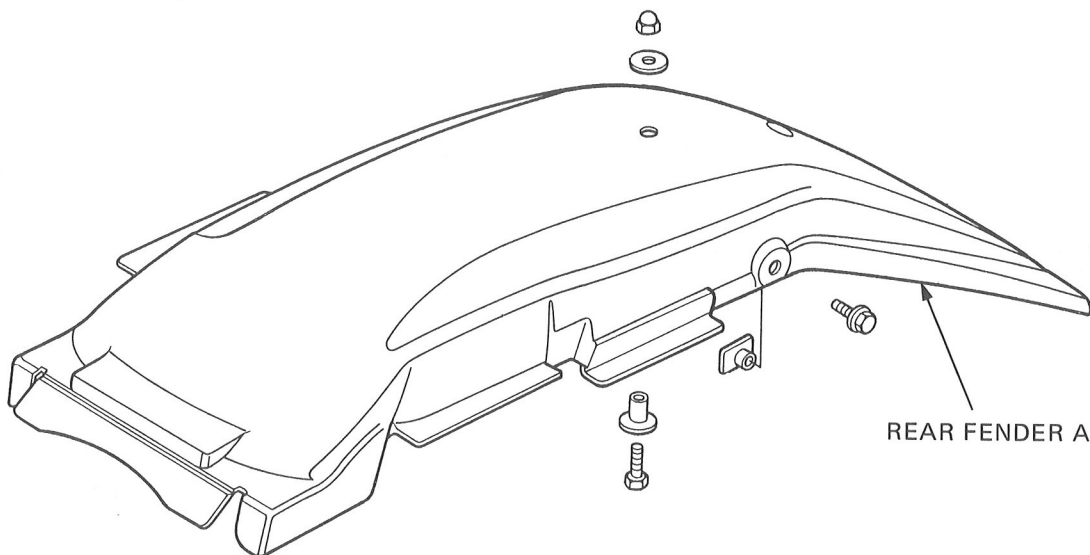
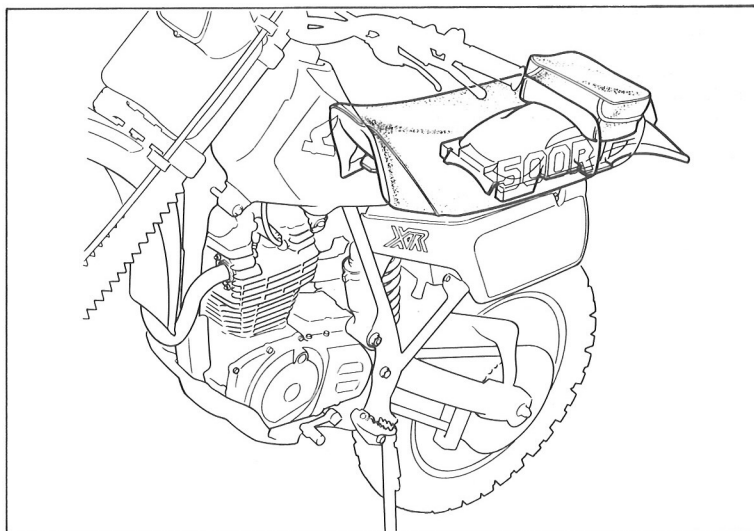



**REAR FENDER/EXHAUST PIPE**

**EXHAUST PIPE**

**WARNING**

*Do not service the exhaust pipes while they are hot.*

**REMOVAL**

Remove the seat.  
Remove the right side cover.  
Loosen the exhaust pipe clamp bolt.

Remove the exhaust pipe joint nuts and remove the exhaust pipe.

Remove the muffler mounting bolts and muffler.  
Check the gasket and pipe seal for wear or damage.  
Replace if necessary.

**INSTALLATION**

Installation is essentially the reverse of removal.

**NOTE**

After installing, make sure that there are no exhaust leaks.

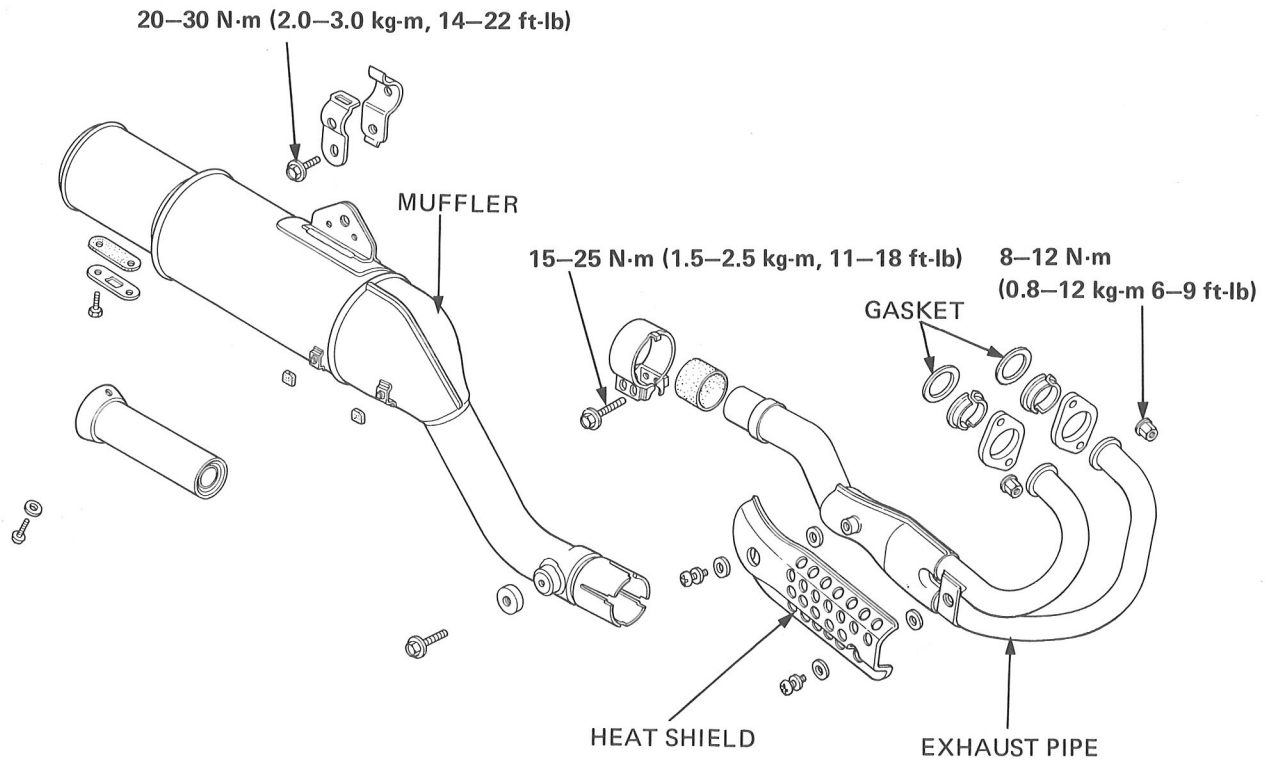
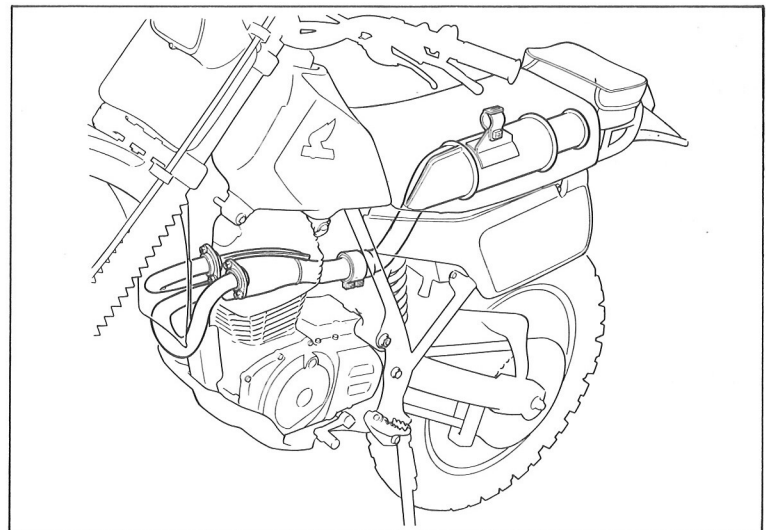



**HONDA**  
**XR500R**

---

MEMO

