



**YAMAHA**

***TZR125RR***

**OWNER'S MANUAL**

4DL - F8199 - W3

**Identification numbers record**

1. Key number (main switch and fuel tank cap):

2. Key number (lock of passenger seat):

3. Frame number and engine number:

Your key identification number is stamped on your key as shown in the following illustration. Record this number in the space provided for reference if you need a new key.

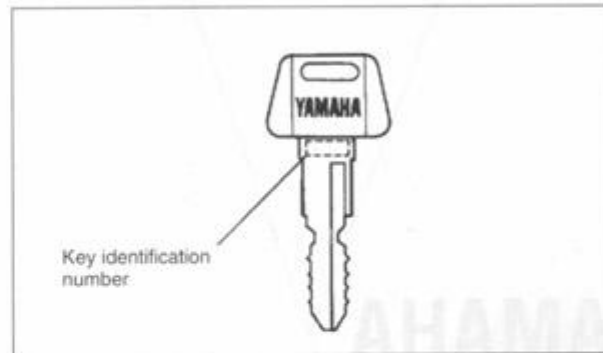

Record your frame and engine number in the spaces provided to assist you in ordering spare parts from your Yamaha dealer or for reference in case your vehicle is stolen. (See page 9).

## INTRODUCTION

Congratulations on your purchase of the Yamaha TZR 125 RR. This model is the result of Yamaha's vast experience in the production of fine sporting, touring, and pacesetter racing machines. It represents the high degree of craftsmanship and reliability that have made Yamaha a leader in these fields.

This manual will give you an understanding of the operation, inspection, and basic maintenance of this motorcycle. If you have any questions about the operation or maintenance of your motorcycle, please consult a Yamaha dealer.

**NOTE:** \_\_\_\_\_  
Some data in this manual may become outdated due to future improvement on this model. If you have any questions about this manual or your motorcycle, please consult a Yamaha dealer.

**NOTE:** \_\_\_\_\_  
This manual should be considered a permanent part of this motorcycle and should remain with it even if the motorcycle is subsequently sold.

---

**WARNING:** \_\_\_\_\_  
**PLEASE READ THIS MANUAL CAREFULLY AND COMPLETELY BEFORE OPERATING THIS MOTORCYCLE.**

Particularly important information is distinguished in this manual by the following notations:

**NOTE:** \_\_\_\_\_  
A NOTE provides key information to make procedures easier or clearer.

**CAUTION:** \_\_\_\_\_  
A CAUTION indicates special procedures that must be followed to avoid damage to the motorcycle.

**WARNING:** \_\_\_\_\_  
A WARNING indicates special procedures that must be followed to avoid injury to a motorcycle operator or person inspecting or repairing the motorcycle.

## INTRODUCTION

### THINK OF YOUR SAFETY:

Both motorcycles and mopeds are fascinating vehicles which give a tremendous feeling of freedom to their riders. They must be correctly maintained at all times in order to ensure optimum performance. However, as a rider you must also ensure that your physical condition is good, and that you are not tired, in order that you too can optimise your vehicle control. Medicines, drugs and alcohol should not be combined with riding, especially alcohol which increases the individual's likelihood of taking risks.

Alcohol is dangerous, even in small quantities.

Correct protective riding gear is just as much a part of motorcycling safety as the safety belt is in the car: a good leather suit and gloves, sturdy boots and a good quality, properly fitting crash helmet are ideal. But beware: good protective clothing can result in the individual being lulled into a false sense of security. When this happens more risks are taken and speeds increase... this particularly applies in wet weather.

The good motorcyclist therefore rides defensively and protectively in order to minimise risks.

## CONTENTS

DESCRIPTION .....	8	Steering lock .....	18
MOTORCYCLE IDENTIFICATION .....	9	Rider seat removal .....	19
Frame serial number .....	9	Passenger seat removal .....	20
Engine serial number .....	9	Helmet holder .....	20
CONTROL FUNCTIONS .....	10	Removing the front fairing .....	21
Main switch .....	10	Removing the rear cowling .....	22
Indicator lights .....	10	Rear shock absorber .....	23
Checking oil level .....	12	Note on handling of the Yamaha	
Speedometer .....	13	Energy Induction System (Y.E.I.S.) .....	23
Tachometer .....	13	Y.P.V.S. (Yamaha Power Valve	
Engine temperature gauge .....	13	System) .....	24
Handlebar switches .....	14	Sidestand .....	25
Electric starting switch .....	15	Sidestand/switch	
Clutch lever .....	15	operation check .....	25
Change pedal .....	15		
Front brake lever .....	16		
Rear brake pedal .....	16	PRE-OPERATION CHECKS .....	26
Fuel tank cap .....	16	Brakes .....	28
Fuel cock .....	17	Brake fluid leakage .....	28
Starter lever (CHOKE) .....	17	Clutch .....	28

Throttle grip .....	28
Engine oil .....	29
Transmission oil .....	29
Coolant.....	29
Chain.....	30
Tires .....	31
Wheels .....	33
Fittings/Fasteners .....	33
Lights and signals .....	33
Switches.....	33
Battery.....	34
Fuel .....	34

#### OPERATION AND IMPORTANT

RIDING POINTS .....	35
Starting a cold engine .....	36
Engine warm-up.....	37
Starting a warm engine .....	37
Shifting .....	37
Engine break-in.....	38
Parking .....	38

#### PERIODIC MAINTENANCE AND

MINOR REPAIR .....	39
Tool kit .....	39
Periodic maintenance/lubrication .....	40
Torque specifications .....	43
Transmission oil level check .....	44
Transmission oil replacement .....	45

Cooling system .....	46
Checking coolant .....	48
Changing coolant .....	48
Air filter .....	50
Carburetor adjustment .....	51
Idle speed adjustment.....	51
Throttle cable adjustment.....	52
Spark plug inspection.....	53
Front brake adjustment .....	54
Rear brake adjustment.....	55
Checking the brake pads .....	55
Inspecting the brake fluid level.....	56
Brake fluid replacement .....	57
Clutch adjustment .....	57
Drive chain slack check .....	58
Drive chain slack adjustment .....	59
Drive chain lubrication.....	60
Cable inspection and lubrication .....	61
Throttle cable and grip lubrication .....	61
Autolube pump adjustment .....	61
Brake and change pedals .....	61
Brake and clutch levers.....	61
Sidestand .....	61
Rear suspension .....	62
Front fork inspection .....	62
Rear shock .....	63
Rear shock absorber adjustment .....	63
Steering inspection .....	65
Wheel bearings .....	65

Battery.....	65
Checking the battery fluid .....	65
Topping up the battery fluid .....	66
Fuse replacement .....	67
Replacing the headlight bulb.....	67
Replacing the front parking light bulb.....	68
Vertical setting of the headlight beam.....	69
Front wheel removal .....	70
Front wheel installation .....	70
Rear wheel removal .....	71

Rear wheel installation.....	71
Troubleshooting .....	72
Troubleshooting chart .....	73

CLEANING AND STORAGE .....	74
A. Cleaning .....	74
B. Storage .....	75

SPECIFICATIONS .....	76
WIRING DIAGRAM .....	80

## DESCRIPTION

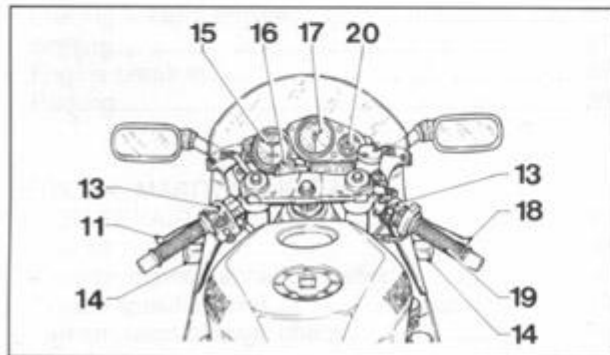
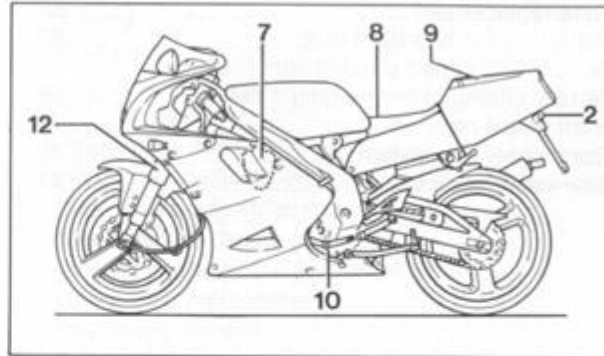
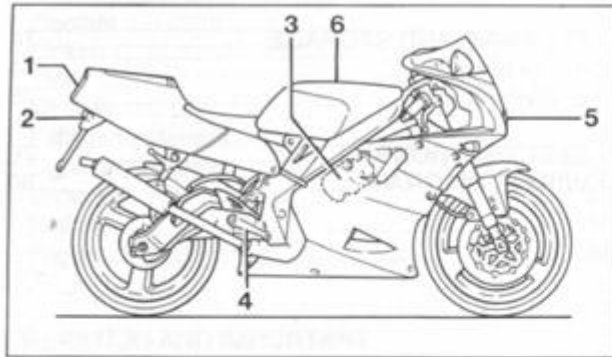

- |                        |                         |
|------------------------|-------------------------|
| 1. Tail/Brake light    | 11. Clutch lever        |
| 2. Rear flasher light  | 12. Front fork          |
| 3. Oil tank            | 13. Handlebar switches  |
| 4. Rear brake pedal    | 14. Front flasher light |
| 5. Headlight           | 15. Odometer            |
| 6. Petrol tank         | 16. Main switch         |
| 7. Expansion tank      | 17. Rev counter         |
| 8. Seat                | 18. Front brake lever   |
| 9. Crash helmet holder | 19. Throttle grip       |
| 10. Change pedal       | 20. Temperature gauge   |

### NOTE:

The motorcycle you have purchased may differ slightly from those shown in the photographs.



## MOTORCYCLE IDENTIFICATION

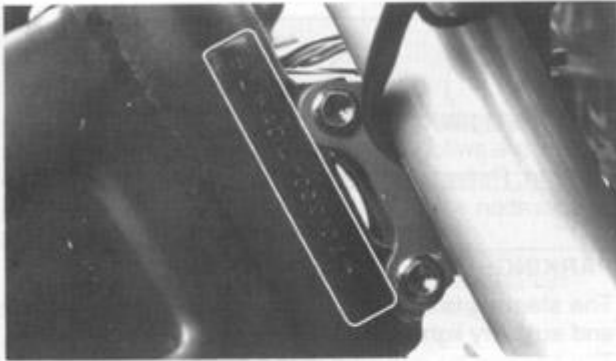

Frame serial number

### Frame serial number

The frame serial number is stamped into the right side of the steering head pipe.

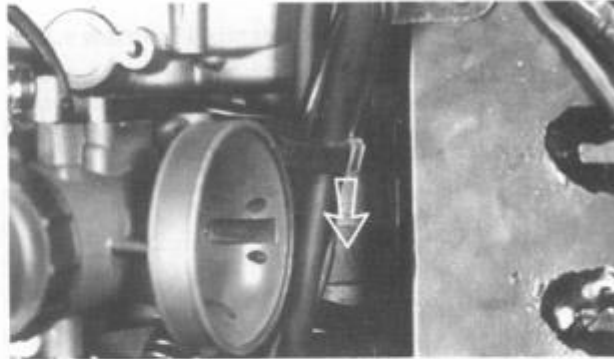

Engine serial number

### Engine serial number

The engine serial number is stamped on the left-hand crankcase under the carburetor.

---

### NOTE:

The first three digits of these numbers are for model identification; the remaining digits are the unit production number. Keep a record of these numbers for reference when ordering parts from a Yamaha dealer.

---

## CONTROL FUNCTIONS

### Main switch

The main switch controls the ignition and lighting systems: its operation is described below.

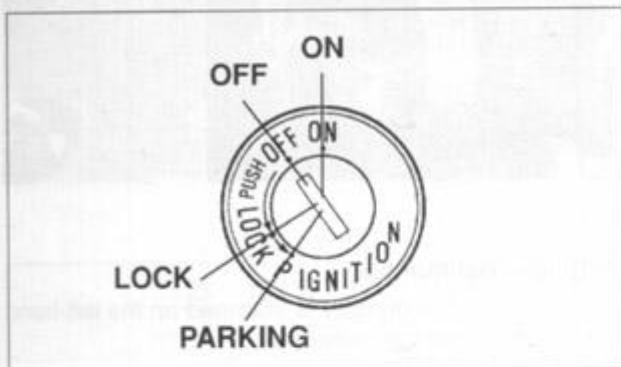

#### ON:

Electrical circuits are switched on. The engine can be started. The key cannot be removed in this position.

#### OFF:

All electrical circuits are switched off. The key can be removed in this position.

#### LOCK:

The steering is locked in this position, and all electrical circuits are switched off. The key can be removed in this position. Refer to «Steering lock» (Page 18), for proper operation.

#### PARKING:

The steering is locked in this position, and the taillight and auxiliary light come on but all other circuits are off. The key can be removed in this position.

#### NOTE:

Always turn the main switch to «OFF» or «LOCK» and remove the key when the motorcycle is unattended.

### Indicator lights

#### «TURN» indicator light (green):

This indicator flashes when the turn switch is «ON».

#### «NEUTRAL» indicator light (green):

This indicator comes on when the transmission is in neutral.

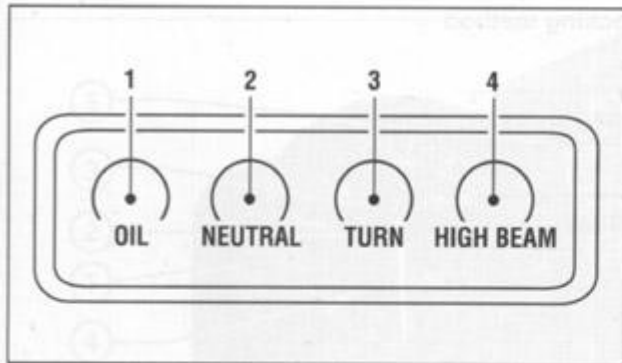

1. Oil level warning indicator light - 2. «NEUTRAL» indicator light -  
3. Direction indicator lights - 4. High-beam indicator light

**«HIGH BEAM» indicator light (blue):**

This indicator comes on when the headlight high beam is used.

**«OIL» warning indicator light (red):**

This indicator comes on when the oil level is low. This light circuit can be checked by the following procedure (see page 12).

**CAUTION:**

Do not run the motorcycle until you know the motorcycle has enough engine oil.

### Oil warning light checking method

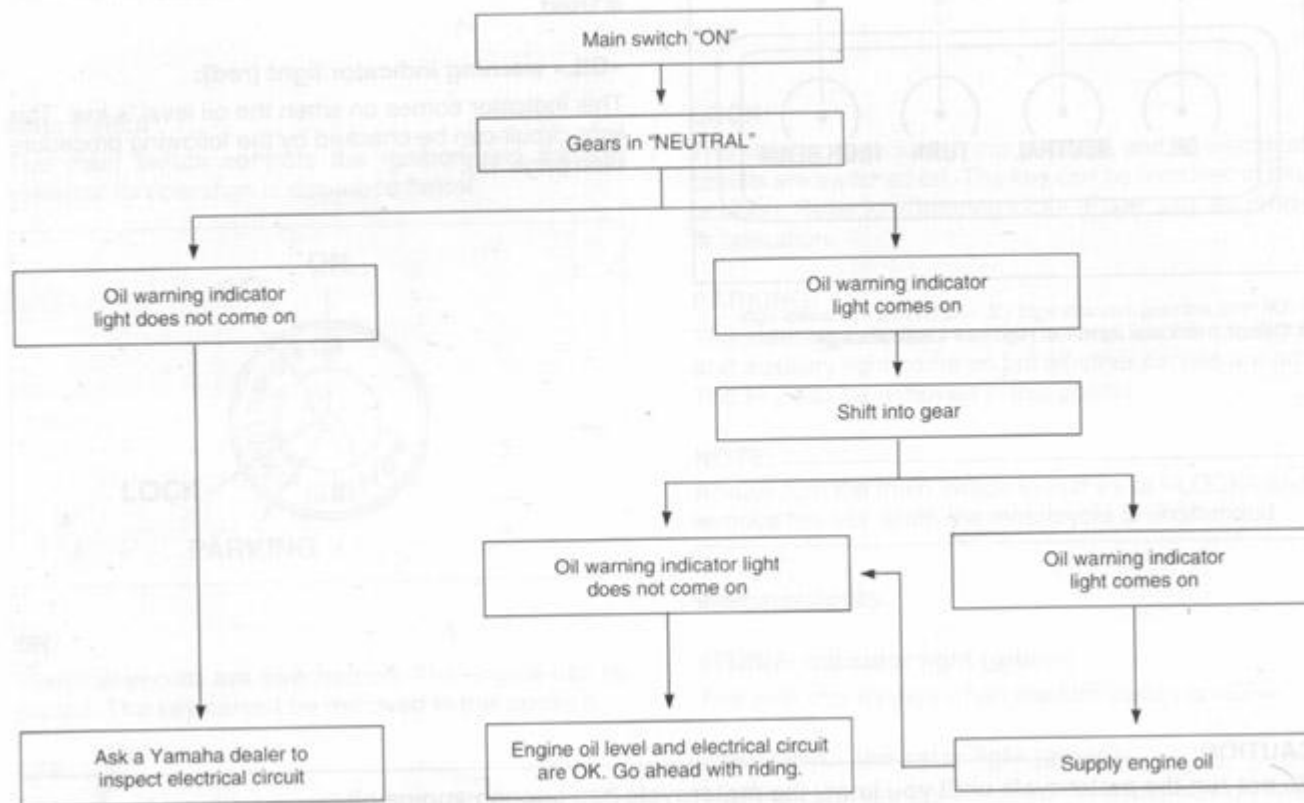

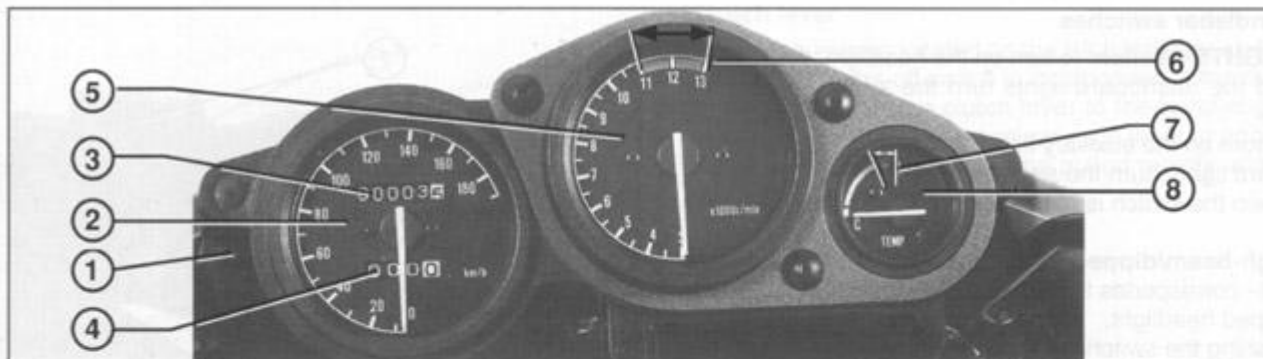

1. Trip counter reset - 2. Speedometer - 3. Odometer - 4. Trip counter - 5. Rev counter - 6. Rev counter red area - 7. Engine temperature gauge red area - 8. Engine temperature gauge

### Instrumentation

**Trip counter:** the trip counter has a reset button. Use the trip counter to calculate the distance you can travel with a full tank of fuel before recourse to the emergency supply (RESERVE). In this way, you can plan fuel stops in advance.

**Rev counter:** this model is fitted with a rev counter to check engine speed. It thus permits full use of the ideal power range.

**CAUTION:** \_\_\_\_\_  
**The rev counter must never exceed 11,000 rpm.**  
 \_\_\_\_\_

**Engine temperature gauge:** with the main switch at ON, the needle indicates the temperature of the coolant. The running temperature varies according to climatic conditions and engine load. If the needle reaches the red area or runs into it, stop the motorcycle and allow the engine to cool (for further details see page 46).

**CAUTION:** \_\_\_\_\_  
**When the engine overheats, turn it off.**  
 \_\_\_\_\_

### Handlebar switches

«**LIGHTS**» switch: to turn on the headlight, the tail light and the dashboard lights turn the switch to position «H».

To turn on the auxiliary light, the tail light and the dashboard lights, turn the switch to position «P».

When the switch is at position «O», all lights are off.

**High-beam/dipped headlight commutator:** position «HI» corresponds to high-beam and position «LO» to a dipped headlight.

Pushing the switch left from position «LO» turns on the flashing indicators (Pass).

**Indicator switch «TURN»:** a triple position switch. To indicate a turn, push in the direction you intend to go. Position «L» corresponds to turning left, position «R» corresponds to turning right. When the switch is released, it returns to the central position. To disengage indicators, press the same switch after its return to the central position.

**Acoustic signal switch «HORN»:** press to activate the acoustic signal.

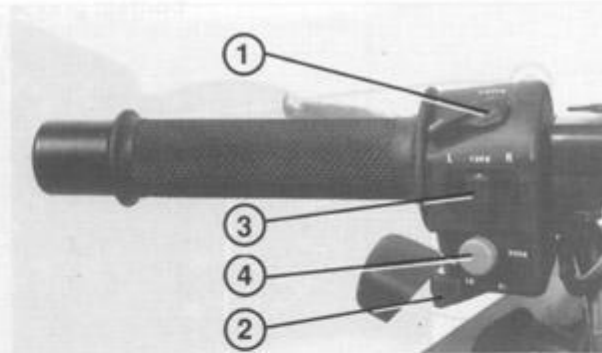

1. «LIGHTS» switch - 2. High-beam/dipped headlight commutator - 3. Direction indicator «TURN» - 4. Acoustic signal switch «HORN».

«**ENGINE STOP**» switch: this switch is a safety device to be used in the event of emergencies (eg, when the motorbike overturns or when the throttle control blocks). «OFF» position: the engine is not running. «ON» position: the engine is running.

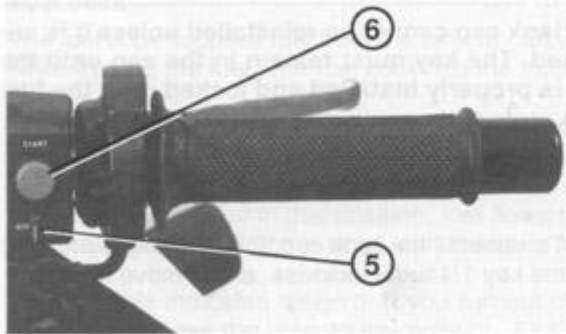

5. «ENGINE STOP» switch - 6. «START» button

**«START» button:** press this button to start the engine (for further details see engine starting procedures on page 36 ff).

**CAUTION:** \_\_\_\_\_  
 Read the starting instructions before starting the engine.  
 \_\_\_\_\_

### Clutch lever

The clutch lever is located on the left handlebar and the starting circuit cut-off switch is incorporated in the clutch lever holder. Pull the clutch lever to the handlebar to disengage the clutch, and release the lever to engage the clutch. The lever should be pulled rapidly and released slowly for smooth starts.

### Change pedal

The gears can be shifted by the pedal on the side panel (L) of the engine.

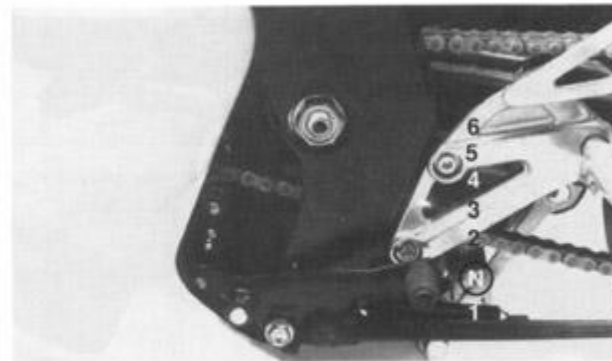

N. Neutral

### Front brake lever

The front brake lever is located on the right handlebar. Pull it toward the handlebar to activate the front brake.

### Rear brake pedal

The rear brake pedal is on the right side of the motorcycle. Press down on the brake pedal to activate the rear brake.

### Fuel tank cap

1. To remove the tank cap, insert the key in the lock and turn the key 1/4 turn counterclockwise.

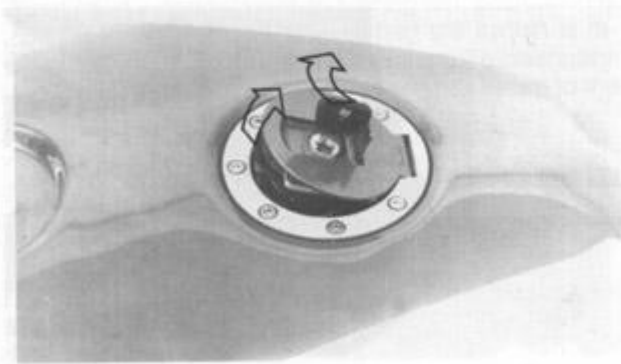

Fuel tank cap.

### NOTE:

The tank cap cannot be reinstalled unless it is unlocked. The key must remain in the cap until the cap is properly installed and locked onto the fuel tank.

2. To reinstall the tank cap, lock the cap by turning the key 1/4 turn clockwise, and remove the key.

### WARNING:

Be sure the cap is properly installed and locked in place before riding the motorcycle.



### Fuel cock

The fuel cock supplies fuel from the tank to carburetor while filtering the fuel. The fuel cock has the three positions:

«OFF»: With the lever in this position, fuel will not flow. Always return the lever to this position when the engine is not running.

«ON»: With the lever in this position, fuel flows to the carburetor. Normal riding is done with the lever in this position.

«RES»: This indicates reserve. If you run out of fuel while riding, move the lever to this position. **FILL THE TANK AT THE FIRST OPPORTUNITY. BE SURE TO SET THE LEVER TO «ON» AFTER REFUELING.**

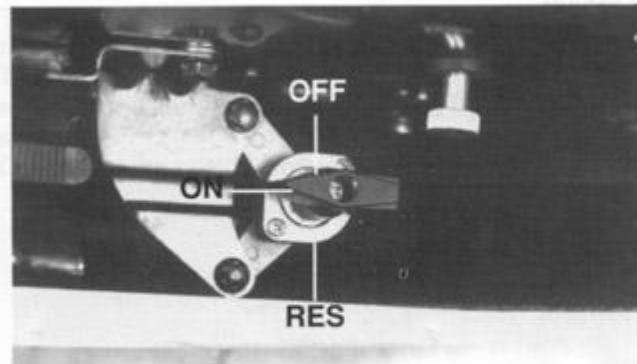

Fuel cock

### Starter lever (CHOKE)

When cold, the engine requires a richer air-fuel mixture for starting. A separate starter circuit supplies this mixture. Pull the starter lever up to open the circuit for starting.

When the engine has warmed up, push the lever down to close the circuit.

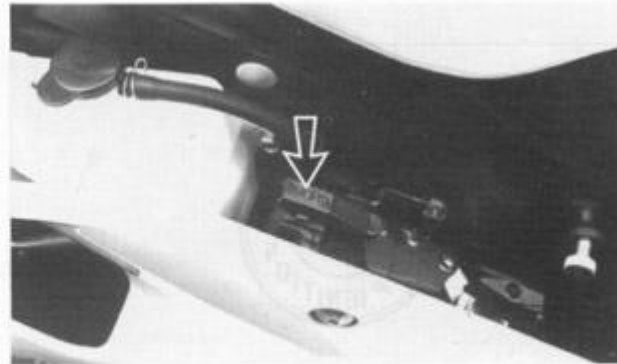

Starter lever (CHOKE)

### Steering lock

Combined with main switch.

The steering is locked when the main switch is turned to «LOCK». To lock the steering, turn the handlebars all the way to the left or right. With the key at «OFF», push it into the main switch, turn the key counterclockwise to «LOCK», and remove the key. To release the lock, turn the key clockwise.

#### WARNING:

Never turn the key to «LOCK» when the engine is running.

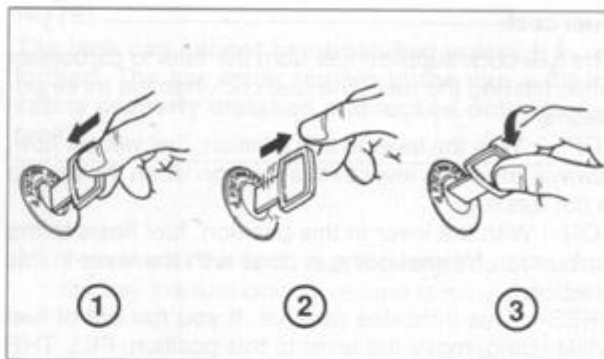

1. Push 2. Release 3. Turn.

### Parking

For «P» turn the key to the «LOCK» position, press, release and turn in an anticlockwise direction. To return to «OFF» simply turn the key right.

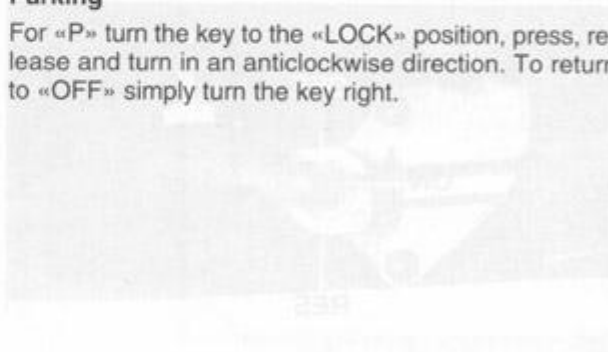

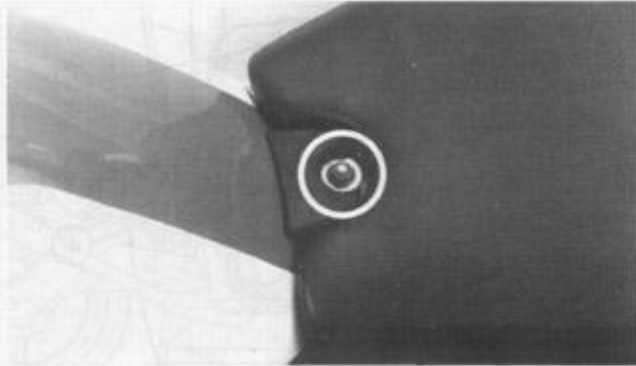

Driver seat fastening screw

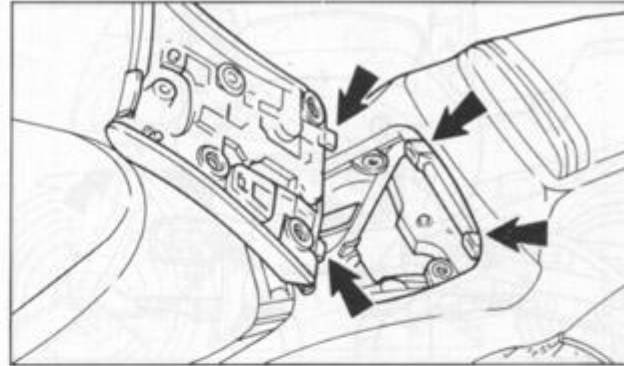

### Rider seat removal

To remove the seat, unscrew the front fastening screw, raise the seat and, at the same time, push it forwards. To replace it, fit the two rear connections into their slides on the frame, lower the seat and tighten the front screw.

Check that the seat is firmly in place.

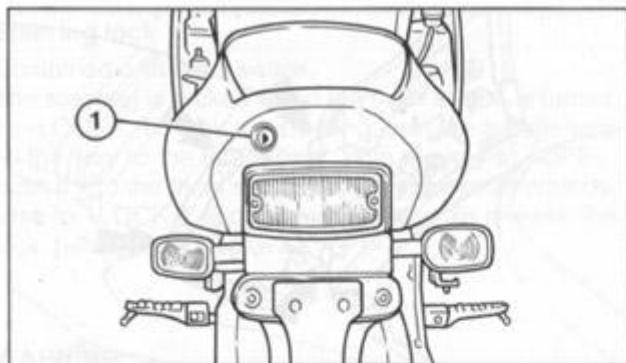

1. Passenger seat lock

### Passenger seat removal

To remove the passenger seat, insert and turn the key in the rear cowling lock, then raise the seat and release it from the fastening pins. To replace the seat, insert the pins into the front part and then press down on the rear until it locks into place.

Check that the seat is firmly in place.

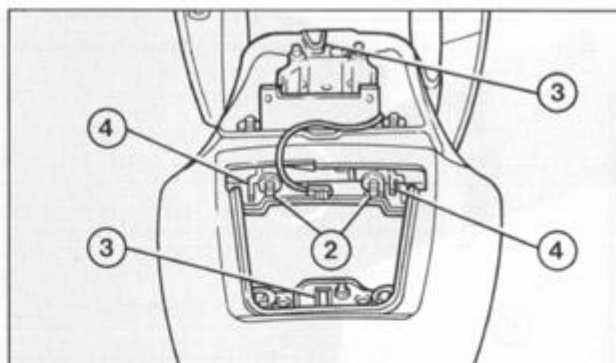

2. Seat fastening pins - 3. Seat locking connection - 4. Crash helmet holder

### Helmet holder

For access to the two helmet holders, remove the passenger seat. After fastening the helmet buckle, replace the seat and lock.

### WARNING

**Do not ride with one or more of the helmets fastened to the helmet holder. They might strike obstacles along the road, thus causing loss of control of the motorcycle and, consequently, accidents.**

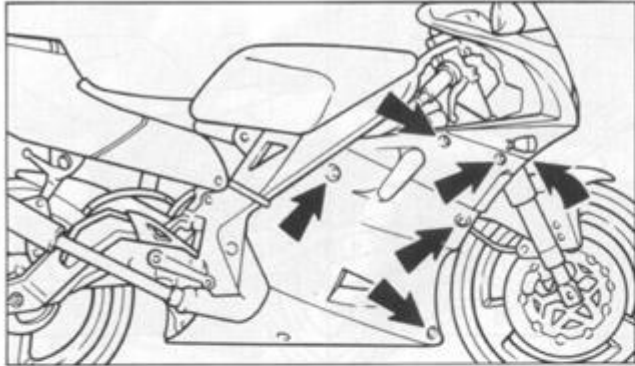

Side panel (R) fastening screws

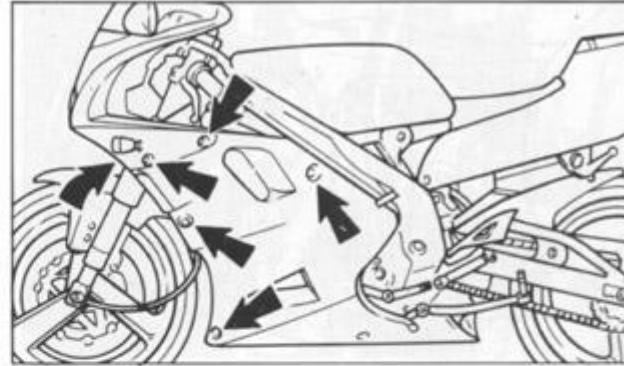

Side panel (L) fastening screws

### Removing the front fairing

1. Set the motorbike on its lateral stand.
2. Remove the five fastening screws on the right-hand panel and the front screw fastened to the internal push rod. Then open the fairing outwards and place it delicately on the ground (this operation alone allows access to the engine).
3. Remove the five fastening screws on the left-hand side, the front screw fastened to the internal push rod and the lower hinge spring.

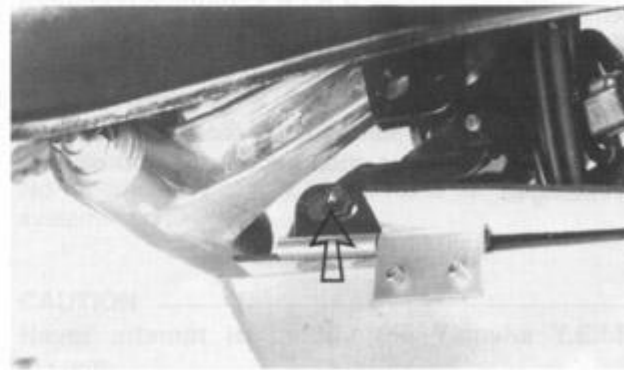

Hinge fastening screw

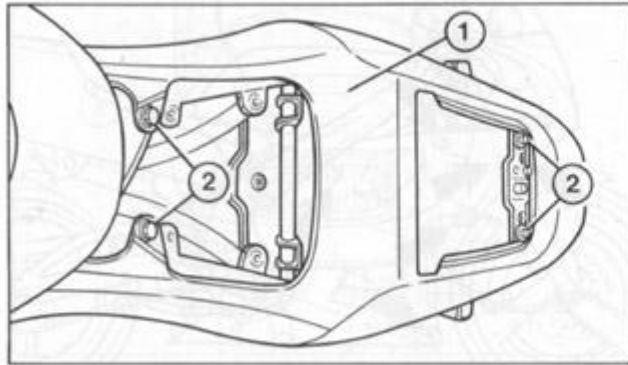

1. Rear cowling - 2. Upper fastening screws

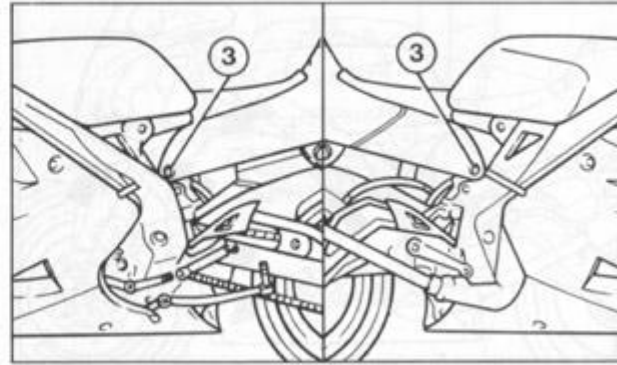

3. Lateral fastening screws

### Removing the rear cowling

Remove the rider and passenger seats (see instructions on pages 19 and 20) and remove the key from the passenger seat lock; remove the two lateral screws and the four upper screws.

Pull the rear cowling panels gently outwards to release the lateral connections, then remove the rear cowling by raising it.

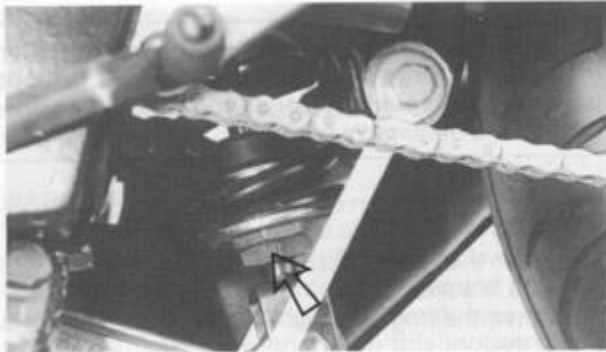

Setting device

### Rear shock absorber

The preloading of the rear shock absorber may be set according to motorcycle load (eg, optional accessories etc) and riding conditions. For setting procedures, see p. 63.

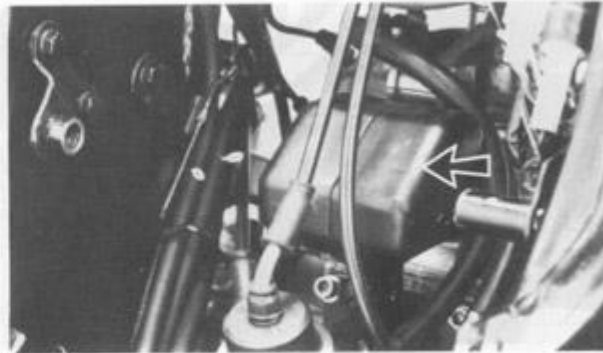

Y.E.I.S.

### Notes on manipulation of the Yamaha Energy Induction System (Y.E.I.S.)

Manipulate the air chamber and hose with the greatest care.

Incorrect assembly or use of damaged parts will cause poor functioning. Substitute cracked or damaged parts immediately.

No modification of any kind should be made to the system.

### CAUTION

Never attempt to modify the Yamaha Y.E.I.S. system.

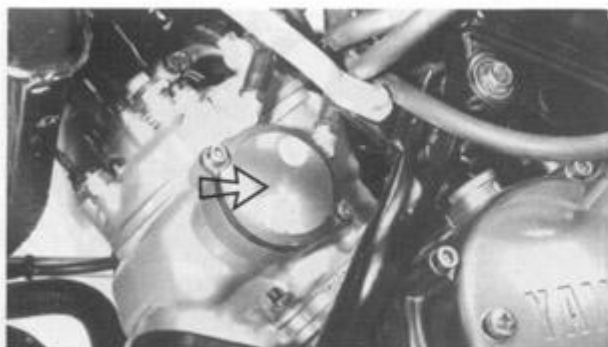

Y.P.V.S.

### Y.P.V.S. (Yamaha Power Valve System)

The Y.P.V.S. is a vital part of the engine and requires very sophisticated adjustment. Adjustment should be left to a Yamaha dealer who has the professional knowledge and experience to do so.

### CAUTION:

The Y.P.V.S. was set at the Yamaha factory after many tests. If the settings are disturbed without having technical knowledge, poor engine performance and damage may result.

The Y.P.V.S. operation can be heard in the following instances:

- When the main switch is turned «ON», and the engine is started.
- When the engine stalls while the main switch is «ON».

### CAUTION:

If the Y.P.V.S. does not operate, ask a Yamaha dealer.



### Sidestand

This model is equipped with an ignition circuit cut-off system. The motorcycle must not be ridden when the sidestand is down. The sidestand is located on the left side of the frame.

#### WARNING:

This motorcycle must not be operated with the sidestand in the down position. If the stand is not properly retracted, it could contact the ground and distract the operator resulting in a possible loss of control. Yamaha has designed into this motorcycle a lockout system to assist the operator in fulfilling his responsibility of retracting the sidestand. Please check carefully the operating instructions listed below and if there is any indication of a malfunction, you must return the motorcycle to a Yamaha dealer immediately for repair.

#### Sidestand switch operation check

Check the operation of the sidestand switch against the information below.

Turn main switch to "ON" and engine stop switch to "RUN".

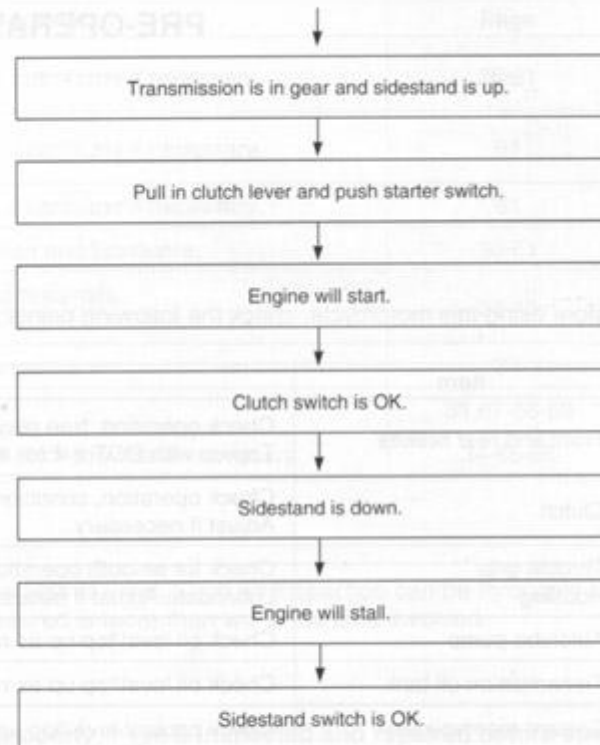

#### WARNING

If improper operation is noted, consult a Yamaha dealer immediately.

## PRE-OPERATION CHECKS

Before using this motorcycle, check the following points:

Item	Routine	Page
Front and rear brakes	Check operation, free play, fluid level, and plunger leakage. Top-up with DOT # 4 (or # 3) brake fluid if necessary.	28-54-55-56
Clutch	Check operation, condition and free play. Adjust if necessary.	28-57-58-61
Throttle grip/ Housing	Check for smooth operation. Lubricate/Adjust if necessary	28-52-61
Autolube pump	Check oil level/top up as required.	61
Transmission oil tank	Check oil level/top up as required.	29-44-45
Coolant reservoir tank	Check coolant level/top up as required.	29-30-46-47-48-49
Drive chain	Check chain slack and condition. Adjust if necessary.	30-58-59-60
Wheels/Tires	Check tire pressure, wear, damage.	31-32-33-70-71
Control/Meter cable	Check for smooth operation. Lubricate if necessary.	61

Item	Routine	Page
Brake and change pedal shafts	Check for smooth operation. Lubricate if necessary.	28-61
Brake and clutch lever pivots	Check for smooth operation. Lubricate if necessary.	61
Sidestand pivot	Check for smooth operation. Lubricate if necessary.	61
Air filter	Spoge tipe-will be always clean and lubricate.	50-51
Fittings/fasteners	Check all chassis fittings and fasteners. Tighten/Adjust, if necessary.	33-43
Fuel tank	Check fuel level/top up as required.	34
Lights and signals	Check for proper operation.	33-67-68-69
Battery	Check fluid level, top up with distilled water if necessary.	34-65-66

**NOTE:** \_\_\_\_\_

Pre-operation checks should be made each time the motorcycle is used. Such an inspection can be thoroughly accomplished in a very short time; and the added safety it assured is more than worth the time involved.

**WARNING:** \_\_\_\_\_

If any item in the Pre-Operation Check is not working properly, have it inspected and repaired before operating the motorcycle.

**Brakes (See page 54 for more detail)**

1. Brake lever and brake pedal:  
Check for correct free play in the front brake lever and rear brake pedal. Make sure they are working properly. Check the brakes at low speed shortly after starting out. If the free play is incorrect, adjust it.

**WARNING:** \_\_\_\_\_

A soft, spongy feeling in the brake lever (and/or brake pedal) indicates a failure in the brake system. Do not operate the motorcycle until the failure in the brake system is corrected. Ask a Yamaha dealer for immediate repairs. A soft, spongy feeling could indicate a hazardous condition in the brake system.

2. Brake fluid:  
Check the brake fluid level.  
Add fluid if necessary.

Recommended brake fluid: DOT # 4

3. Check the disc pads.  
Refer to page 55.

**NOTE:** \_\_\_\_\_

When this brake service is necessary, ask a Yamaha dealer.

**Brake fluid leakage (front and rear)**

Apply each brake for a few minutes. Check to see if any brake fluid leaks out from the pipe joints or the master cylinder(s)

**WARNING:** \_\_\_\_\_

If brake fluid leakage is found, ask a Yamaha dealer for immediate repairs. Such leakage could indicate a hazardous condition.

**Clutch (See page 57 for more detail)**

Check the free play in the clutch lever, and make sure the lever operates properly.  
If the free play is incorrect, adjust it.

**Throttle grip (See page 52 for more detail)**

Turn the throttle grip to see if it operates properly, and check the free play. Make sure the grip returns by spring force when released. Ask a Yamaha dealer to make any necessary adjustments.

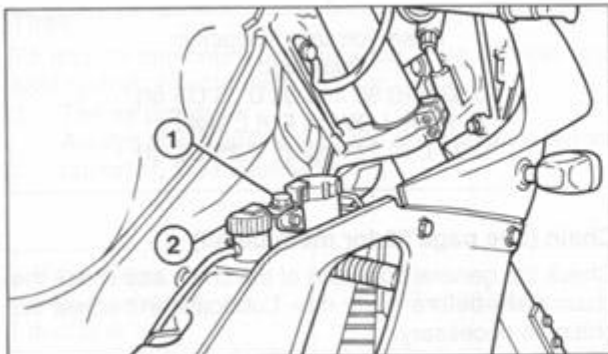

1 Antiunscrewing plate fastening screw - 2. Engine oil tank cap.

### Engine oil

When the «OIL» light on the dashboard turns on, this indicates that there is a shortage of engine oil. To top up the oil level, first remove the fastening screw (1) then the antiunscrewing plate, unscrew the oil tank cap (2) of the oil tank and add a suitable quantity of the oil prescribed.

Recommended oil:  
Oil Shell Super 2 TX  
for air-cooled 2T engines.  
Oil tank capacity:  
Total: 1.4 l

### NOTE

Fit the oil tank filling cap and tighten firmly. Fit the anti-unscrewing plate.

### Transmission oil

Make sure the transmission oil is at the specified level. Add oil as necessary.

Recommended oil:  
SAE 10W30 type SE motor oil  
Oil quantity:  
Total amount:  
0.8 L (0.7 Imp qt. 0.9 us qt)  
Periodic oil change:  
0.75 L (0.66 Imp qt. 0.79 us qt)

### Coolant

Check the coolant level in the reservoir tank when the engine is cold. (The coolant level will vary with engine temperature). The coolant level is satisfactory if it is between the FULL and LOW marks on the tank. If the coolant level is at or below the LOW level, add tap water (soft water) to bring the level up to FULL. Change the coolant every two years (See page 46 for more detail).

**WARNING:** \_\_\_\_\_  
Do not remove the radiator cap when the engine is hot.

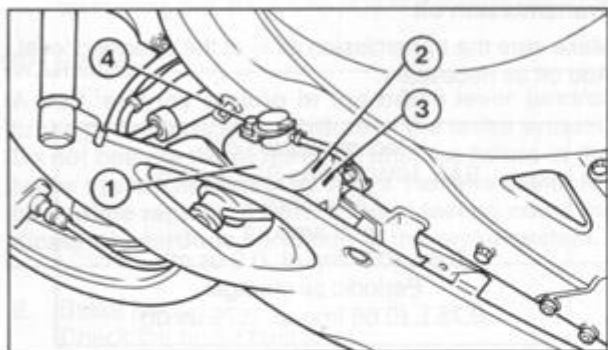

1. Expansion tank - 2. «FULL» mark (maximum level) - 3. «LOW» mark (minimum level) - 4. Antiunscrewing plate

**CAUTION:** \_\_\_\_\_  
Hard water or salt water is harmful to the engine. You may use distilled water if you can't get soft water.

Reservoir tank capacity:  
Full level:  
0.33 L (0.30 Imp qt, 0.35 US qt)  
From LOW to FULL level:  
0.24 L (0.21 Imp qt, 0.25 US qt)

**Chain (See page 58 for more detail)**

Check the general condition of the chain and check the chain slack before every ride. Lubricate and adjust the chain as necessary.

## Tires

To ensure maximum performance, long service, and safe operation, note the following:

1. Tire air pressure:  
Always check and adjust the tire pressure before operating the motorcycle.

Basic weight: With oil and full fuel tank	137 kg (62 lbs)	
Maximum load*	170 kg (375 lbs)	
Cold tire pressure	Front	Rear
Up to 90 kg (198 lbs) load*	190 KPa (1.9 kg/cm <sup>2</sup> , 26 psi)	210 KPa (2.1 kg/cm <sup>2</sup> , 31 psi)
90 kg (198 lbs) Maximum load*	210 KPa (2.1 kg/cm <sup>2</sup> , 31 psi)	220 KPa (2.2 kg/cm <sup>2</sup> , 32 psi)

\* Load is the total weight of cargo, rider, passenger and accessories.

## WARNING:

Tire inflation pressure should be checked and adjusted when the temperature of the tire equals the ambient air temperature. Tire inflation pressure must be adjusted according to total weight of cargo, rider, passenger, and accessories (fairing, saddlebags, etc. if approved for this model), and vehicle speed.

Proper loading of your motorcycle is important for the handling, braking, and other performance and safety characteristics of your motorcycle. Do not carry loosely packed items that can shift. Securely pack your heaviest items close to the center of the motorcycle, and distribute the weight evenly from side to side. Properly adjust the suspension for your load, and check the condition and pressure of your tires. **NEVER OVERLOAD YOUR MOTORCYCLE.** Make sure the total weight of the cargo, rider, passenger, and accessories (fairing, saddlebags, etc. if approved for this model) does not exceed the maximum load of the motorcycle. Operation of an overloaded motorcycle could cause tire damage, an accident, or even injury.

2. Tire inspection:

Always check the tires before operating the motorcycle. If center tread depth reaches the limit as shown, if the tire has a nail or glass fragments in it, or if the side wall is cracked, contact a Yamaha dealer immediately and have him replace the tire.

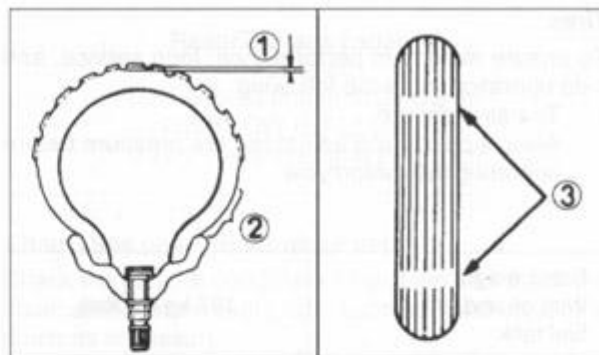

1. Tread depth. 2. Side wall. 3. Wear indicator.

FRONT:

Manufacture	Size	Type
Dunlop	110/70-TR17*	SPORTMAX TL
Pirelli (in alternative)	110/70-ZR17* 120/60-ZR17*	MP7

Minimum tire tread depth (front and rear)	1.0 mm (0.04 in)
---	------------------

REAR:

Manufacture	Size	Type
Dunlop	140/70-TR17*	SPORTMAX TL
Pirelli	150/60-ZR17*	MP7

**NOTE:**

These limits may be different by regulation from country to country. If so, conform to the limits specified by the regulations of your own country.



**WARNING:**

1. Operating the motorcycle with excessively worn tires decrease riding stability and can lead to loss of control. Have excessively worn tires replaced by a Yamaha dealer immediately. Brakes, tires and related wheel parts replacement should be left to a Yamaha Service Technician.
2. Patching a punctured tube is not recommended. If it is absolutely necessary to do so, use great care and replace the tube as soon as possible with a good quality replacement.

**Wheels**

To ensure maximum performance, long service, and safe operation, note the following:

1. Always inspect the wheels before a ride. Check for cracks, bends, or warpage of the wheel. If any abnormal condition exists in a wheel, consult a Yamaha dealer. Do not attempt even small repairs to the wheel. If a wheel is deformed or cracked, it must be replaced.
2. Tires and wheels should be balanced whenever either one is changed or replaced. Failure to have a wheel balanced can result in poor performance adverse handling characteristics, and shortened tire life.

3. After installing a tire, ride conservatively to allow the tire to seat itself on the rim properly. Failure to allow proper seating may cause tire failure, resulting in damage to the motorcycle and injury to the rider.

**Fittings/Fasteners**

Always check the tightness of chassis fittings and fasteners before a ride. Use the chart on page 43 to find the correct torque.

**Lights and signals**

Check the headlight, flasher lights, taillight, brake light, meter lights, and all the indicator lights to make sure they are in working condition.

**Switches**

Check the operation of the headlight switch, turn switch, brake light switch, horn switch, main switch, etc.

**Battery (See page 65 for more detail)**

Check the fluid level and top-up if necessary. Use only distilled water if refilling is necessary.

**Fuel**

Make sure there is sufficient fuel in the tank.

**WARNING:**

**Do not overfill the fuel tank. Avoid spilling fuel on the hot engine. Do not fill the fuel tank above the bottom of the filler tube as shown in the illustration or it may overflow when the fuel heats up later and expands.**

Recommended fuel:  
Premium gasoline  
For Switzerland:  
**UNLEADED PETROL ONLY**  
Fuel tank capacity:  
Total:  
13.0 L (2.8 Imp gal)  
Reserve:  
2 L (0.45 Imp gal)

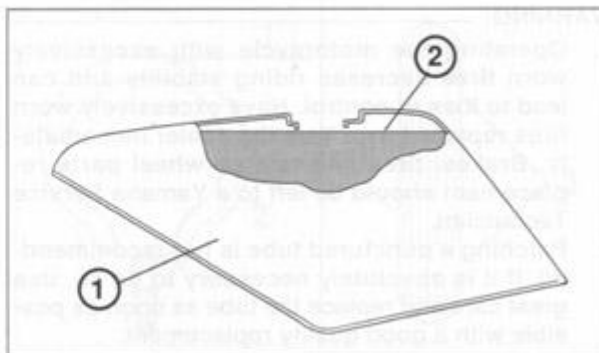

1. Fuel tank. 2. Fuel MAX level.

## OPERATION AND IMPORTANT RIDING POINTS

**WARNING:** \_\_\_\_\_

Before riding this motorcycle, become thoroughly familiar with all operating controls and their function. Consult a Yamaha dealer regarding any control or function that you do not thoroughly understand.

**WARNING:** \_\_\_\_\_

1. Never start your engine or let it run for any length of time in a closed area. The exhaust fumes are poisonous and can cause loss of consciousness and death within a short time. Always operate your motorcycle in an area with adequate ventilation.
2. Before starting out, always be sure the sidestand is up. Failure to retract the sidestand completely can result in a serious accident when you try to turn a corner.

### Starting a cold engine

**NOTE:**

This motorcycle is equipped with a starting and an ignition circuit cut-off switch.

The engine can be started only under the following conditions:

- a. The transmission is in neutral and the sidestand is down.
- b. The sidestand is up, the transmission is in gear, and the clutch is disengaged.

**WARNING:** \_\_\_\_\_

Before going through the following steps, check the function of the sidestand switch and clutch switch. (Refer to page 25).

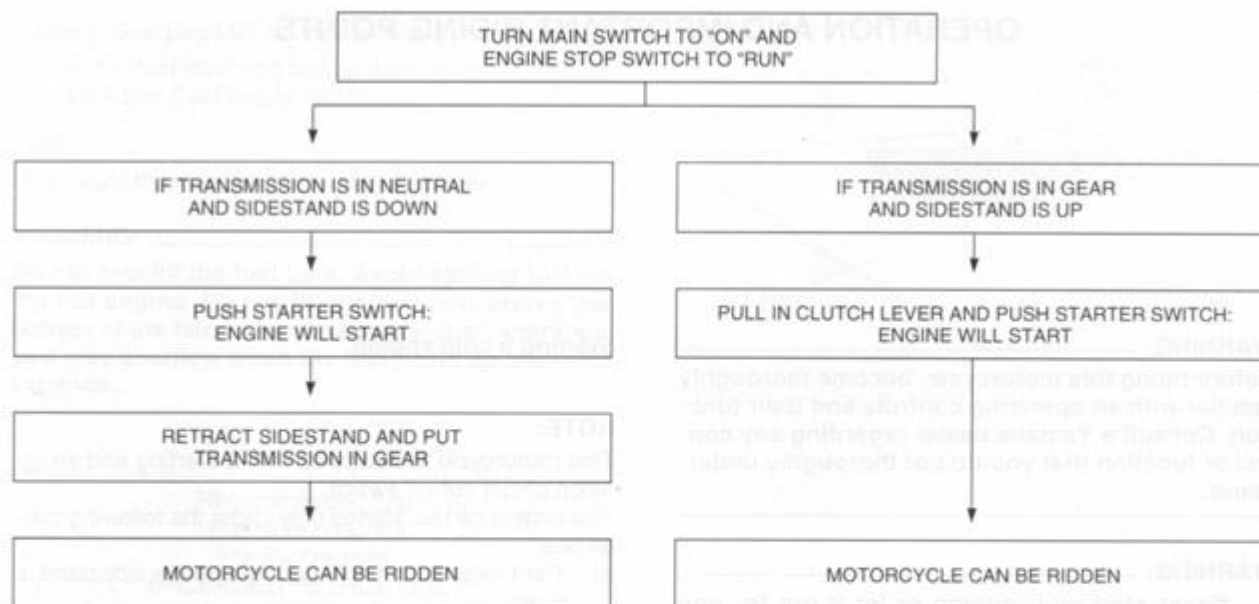

#### Starting a cold engine

1. Turn the fuel cock to «ON».
2. Turn the ignition key to «ON» and the engine stop switch to «RUN».
3. Shift transmission into neutral.

36

#### NOTE:

When the transmission is in neutral, the neutral indicator light (green) should be on. If the light does not come on, ask a Yamaha dealer to inspect it.

4. Open the starter (CHOKE), and completely close the throttle grip.
5. Start the engine by pushing the starter switch.
6. After the engine starts, warm it up for one or two minutes. Make sure the starter is returned to its original position before riding.

**NOTE:**

If the engine fails to start, release the starter switch, wait a few seconds, then try again. Each attempt should be as short as possible to preserve the battery. Do not crank the engine more than 10 seconds on any one attempt.

**Engine warm-up**

To ensure maximum engine life, always warm up the engine before riding your motorcycle. Never accelerate hard with a cold engine. An engine is warm if it responds normally to the throttle when the starter (CHOKE) is turned off.

**Starting a warm engine**

The starter (CHOKE) is not required when the engine is warm.

**CAUTION:**

See «Break-in section» prior to operating the motorcycle for the first time.

**Shifting**

The transmission lets you control the amount of power you have available at a given speed for starting, accelerating, climbing hills, etc. The use of the change pedal is shown in the illustration. (Page 15).

To shift into NEUTRAL, depress the change pedal repeatedly until it reaches the end of its travel (you will feel a stop when you are in first gear) then raise the pedal slightly.

**CAUTION:**

1. Do not coast for long periods with the engine off, and do not tow the motorcycle a long distance. Even with gears in neutral the transmission is only properly lubricated when the engine is running. Inadequate lubrication may damage the transmission.
2. Always use the clutch when changing gears. The engine, transmission, and driveline are not designed to withstand the shock of forced shifting and can be damaged by shifting without the clutch.

### Engine break-in

There is never a more important period in the life of your motorcycle than the period between zero and 1,000 km (600 mi). For this reason we ask that you carefully read the following material. Because the engine is brand new, you must not put an excessive load on it for the first 1,000 km (600 mi). The various parts in the engine wear and polish themselves to the correct operating clearances. During this period, prolonged full throttle operation or any condition which might result in excessive heating of the engine, must be avoided.

1. 0-500 km (0-300 mi):  
Avoid operation above 6,500 r/min. Stop the engine and let it cool for 5 to 10 minutes after every hour of operation.  
Vary the speed of the motorcycle from time to time. Do not operate it at one set throttle position.
2. 500-1,000 km (300-600 mi):  
Avoid prolonged operation above 7,500 r/min. Rev the motorcycle freely through the gears, but do not use full throttle at any time.

**CAUTION:** \_\_\_\_\_  
**After 1,000 km (600 mi) of operation, be sure to replace the transmission oil.**

---

3. 1,000 km (600 mi) and beyond:  
Full throttle can be used.

**CAUTION:** \_\_\_\_\_  
**Never let engine speeds enter the red zone.**

---

**CAUTION:** \_\_\_\_\_  
**If any engine trouble should occur during the break-in period, consult a Yamaha dealer immediately.**

---

### Parking

When parking the motorcycle, stop the engine and remove the ignition key. Turn the fuel cock to «OFF» whenever stopping the engine.

**WARNING:** \_\_\_\_\_  
**The muffler and exhaust pipe are hot. Park the motorcycle in a place where pedestrians or children are not likely to touch the motorcycle.**  
**Do not park the motorcycle on a slope or soft ground; the motorcycle may overturn.**

---

## PERIODIC MAINTENANCE AND MINOR REPAIR

Periodic inspection, adjustment, and lubrication will keep your motorcycle in the safest and most efficient condition possible. **Safety is an obligation of the motorcycle owner.** The maintenance and lubrication schedule chart should be considered strictly as a guide to general maintenance and lubrication intervals. YOU MUST TAKE INTO CONSIDERATION THAT WEATHER TERRAIN, GEOGRAPHICAL LOCATIONS AND A VARIETY OF INDIVIDUAL USES ALL TEND TO DEMAND THAT EACH OWNER ALTER THIS TIME SCHEDULE TO SHORTER INTERVALS TO MATCH HIS ENVIRONMENT. The most important points of motorcycle inspection, adjustment, and lubrication are explained in the following pages.

**WARNING:** \_\_\_\_\_  
**If you are not familiar with motorcycle service, this work should be done by a Yamaha dealer.**

### Tool kit

The service information included in this manual is intended to provide you, the owner, with the necessary information for completing some of your own preventive maintenance and minor repairs. The tools provided in the owner's tool kit are sufficient for most of these purposes; however a torque wrench is also necessary to properly tighten nuts and bolts.

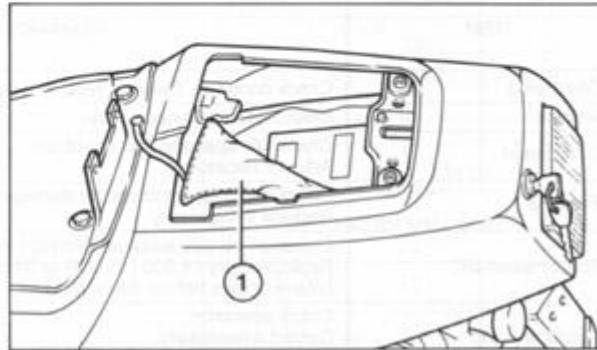

1. Tool bag and document holder

**NOTE:** \_\_\_\_\_  
If you do not have a torque wrench available during a service operation requiring one, take your motorcycle to a Yamaha dealer to check the torque settings and adjust them as necessary.

**WARNING:** \_\_\_\_\_  
**Modifications to this motorcycle not approved by Yamaha may cause loss of performance, and render it unsafe for use. Consult a Yamaha dealer before attempting any changes.**

## PERIODIC MAINTENANCE/LUBRICATION

Unit: km (miles)

ITEM	REMARKS	Break-in 1,000 (600)	EVERY	
			6,000 (4,000) or 6 months	12,000 (8,000) or 12 months
Spark plug	Check condition. Clean or replace if necessary.	○	○	○*
Air filter	Clean. Replace if necessary.		○	○
Carburetor*	Check idle speed/starter operation. Adjust if necessary.	○	○	○
Fuel line	Check fuel hose for cracks or damage. Replace if necessary.		○	○
Transmission oil*	Check oil level/oil leakage. Correct if necessary. Replace every 24,000 (16,000) or 24 months (Warm engine before draining).	Replace	○	○
Autolube pump*	Check operation. Correct if necessary. Air bleeding.	○	○	○
Brakes*	Check operation/fluid leakage/See NOTE. Correct if necessary.		○	○
Clutch	Check operation. Adjust if necessary.		○	○
Rear arm pivot*	Check rear arm assembly for looseness. Correct if necessary. Moderately lube.***	○	○	○
Rear suspension link pivots*	Check operation. Moderately lube.***	○	○	○
Wheels*	Check balance/damage/ runout. Repair if necessary.		○	○
Wheel bearing*	Check bearings assembly for looseness/damage. Replace if necessary.		○	○
Steering bearing*	Check bearings assembly for looseness. Correct if necessary. Moderately lube every 24,000 (16,000) or 24 months.**	○		○



ITEM	REMARKS	Break-in 1,000 (600)	EVERY	
			6,000 (4,000) or 6 months	12,000 (8,000) or 12 months
Front forks*	Check operation/oil leakage. Repair if necessary.		○	○
Rear shock absorber*	Check operation/oil leakage. Repair if necessary.		○	○
Cooling system	Check coolant leakage. Repair if necessary. Replace coolant every 24,000 (16,000) or 24 months.		○	○
Drive chain	Check chain slack/alignment. Adjust if necessary. Clean and lube.	EVERY 500 (300)		
Fittings/ Fasteners*	Check all chassis fittings and fasteners. Correct if necessary.	○	○	○
Sidestand*	Check operation. Repair if necessary.	○	○	○
Sidestand switch*	Check operation. Clean or replace if necessary.	○	○	○
Battery*	Check specific gravity. Check breather pipe for proper operation. Correct if necessary.		○	○

\* : It is recommended that these items be serviced by a Yamaha dealer.

\*\* : Medium weight wheel bearing grease.

\*\*\*: Lithium soap base grease.

**NOTE:**

Brake fluid replacement:

1. When disassembling the master cylinder or caliper, replace the brake fluid. Normally check the brake fluid level and add the fluid as required.
2. On the inner parts of the master cylinder and caliper cylinder, replace the oil seals every two years.
3. Replace the brake hoses every four years, or if cracked or damaged.

### Torque specifications

Use a torque wrench to tighten these items. It is recommended that these items be checked occasionally, especially before a long trip. Always check the tightness of these items whenever they are loosened for any reason.

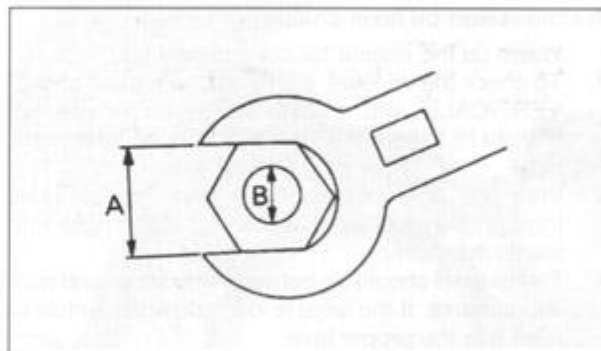

A (Nut)	B (Bolt)	General torque specifications		
		Nm	m·kg	ft·lb
10 mm	6 mm	6	0.6	4.3
12 mm	8 mm	15	1.5	11
14 mm	10 mm	30	3.0	22
17 mm	12 mm	55	5.5	40
19 mm	14 mm	85	8.5	61
22 mm	16 mm	130	13.0	94

Item	Torque		
	Nm	m·kg	ft·lb
Spark plug	20	2.0	14
Engine drain bolt	15	1.5	11
Coolant drain bolt	10	1.0	7.2
Shock absorber - Nut	22	2.2	16
Front wheel axle	70	7.0	50
Axle holder nut	10	1.0	7.2
Rear wheel axle nut	80	8.0	58

### Transmission oil level check

1. Warm up the engine for several minutes.
2. To check the oil level, the motorcycle must stand VERTICALLY with its both wheels on the ground. A slight tilt toward the side can produce false readings.
3. With the engine stopped, check the oil level through the level window located at the right side crankcase cover.
4. The oil level should be between maximum and minimum marks. If the level is low, add sufficient oil to raise it to the proper level.

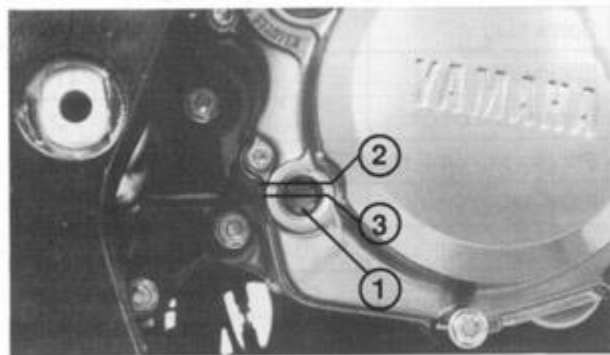

1. Level window. 2. Maximum mark. 3. Minimum mark.

Recommended oil:  
SAE 10W30 type SE motor oil  
Oil quantity:  
0.8 L (0.7 Imp qt, 0.9 US qt)

**CAUTION:**  
Do not add any chemical additives. Transmission oil also lubricates the clutch and additives could cause clutch slippage.

**CAUTION:**  
Be sure no foreign material enters the crankcase.

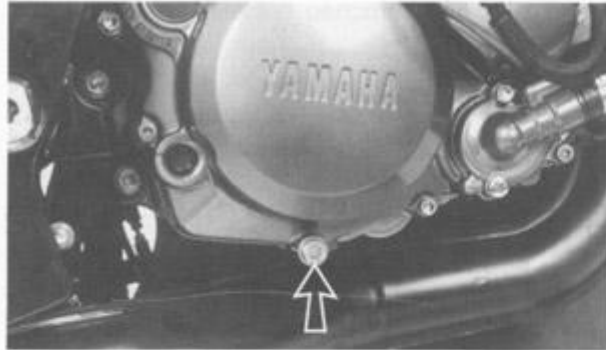

1. Drain plug.



1. Oil filler cap.

### Transmission oil replacement

1. Open the side panel (R) of the fairing following the instructions on page 21.
2. To drain the oil, warm up the engine for several minutes.
3. Place an oil pan under the engine.
4. Remove the drain plug and drain the oil.
5. Reinstall the drain plug (make sure it is tight).

Drain plug torque:  
15 Nm (1.5 m·kg, 11 ft·lb)

6. Add oil through the oil filler hole.

Periodic oil change:  
0.75 L (0.66 Imp qt, 0.79 US qt)

7. After replacement of transmission oil, be sure to check for oil leaks.

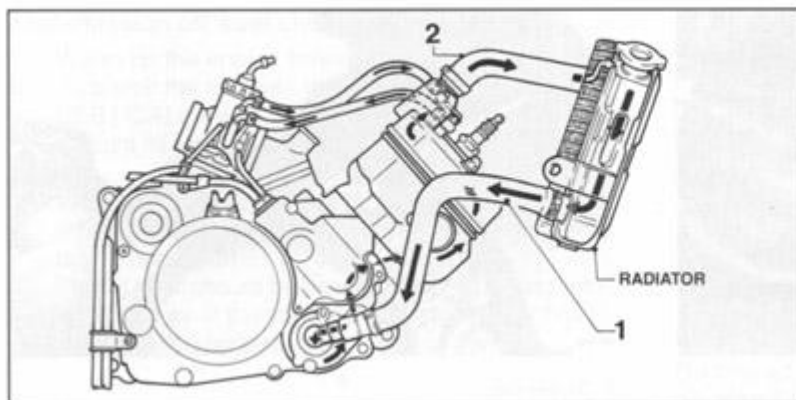

### Cooling system

The coolant is circulated by an impeller type pump mounted on the right-hand crankcase and driven by a gear. The coolant is drawn by the pump from the bottom tank of the radiator, through the pipe (1), and discharged into the cylinder and cylinder-head. The coolant passes from the cylinder to the cylinder-head through coolant passages. After circulating around the combustion chamber jacket, it enters the radiator upper tank via the pipe (2). The heated coolant from the engine then passes down through the finned tubes to the bottom tank of the radiator. These finned tubes present a large surface area to the air and dissipate the heat.

### WARNING:

Do not remove the radiator cap when the engine and radiator are hot. Scalding hot fluid and steam may be blown out under pressure, which could cause serious injury. When open the radiator cap, note the following points. Wait until the engine has cooled. Place the thick rag like a towel over the radiator cap and slowly rotate the cap counterclockwise to the detent. This procedure allows any residual pressure to escape. When the hissing sound has stopped, press down on the cap while turning counterclockwise and remove it.

If overheating is detected, perform the following checks.

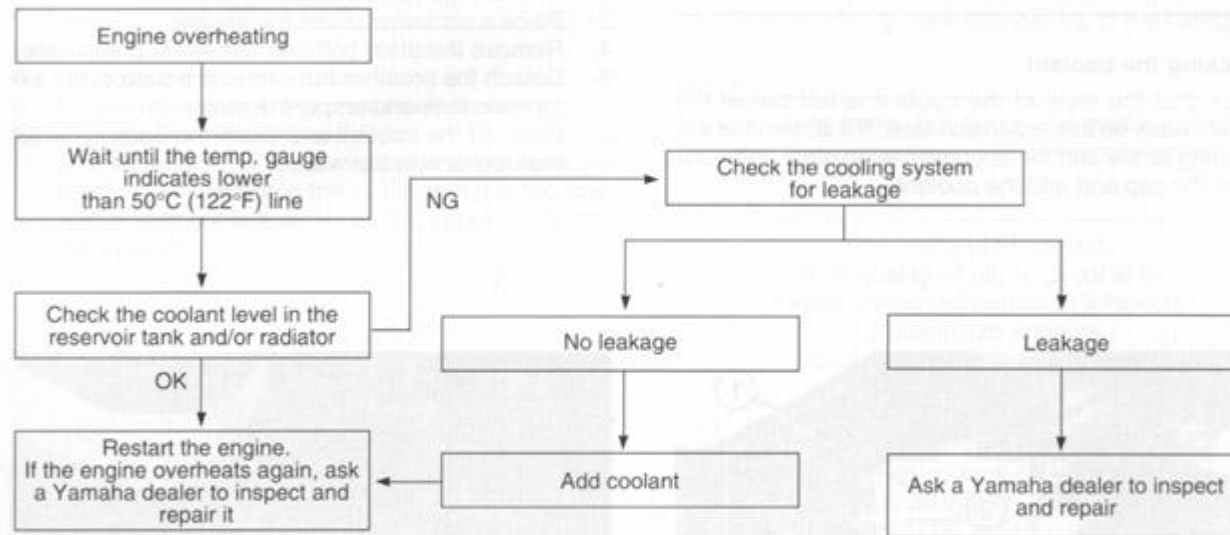

**NOTE :**

If it is difficult to get the recommended coolant, tap water can be temporarily used, provided that it is changed to the recommended coolant as soon as possible.

**Checking the coolant**

Check that the level of the coolant is not below the «LOW» mark on the expansion tank. If it is, remove the fastening screw and the antiunscrewing plate, then unscrew the cap and add the coolant.

**Changing the coolant**

1. Remove the two side panels of the fairing following the instructions on pages 21-22.
2. Remove the radiator cap.
3. Place a container under the engine.
4. Remove the drain bolt from the water pump case.
5. Detach the breather hose from the base of the expansion tank and empty the tank.
6. Drain all the coolant and wash the cooling circuit thoroughly with tap water.

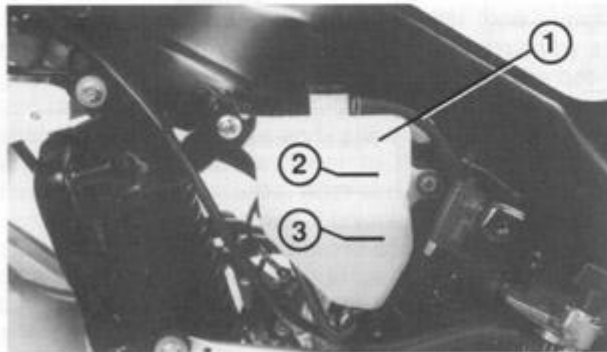

1. Expansion tank - 2. «FULL» mark (maximum level) -  
3. «LOW» mark (minimum level)



Radiator cap



7. Fasten the drain bolt to the pump case.

Drain bolt torque:  
10 Nm (1.0 m·kg, 7.2 ft·lb)

8. Replace the breather hose.
9. Fill the radiator with the prescribed coolant.
10. Replace the radiator cap.
11. Run the engine for a few minutes, then recheck the level of the coolant in the radiator. If it is too low, top up with coolant as far as the upper section of the radiator.

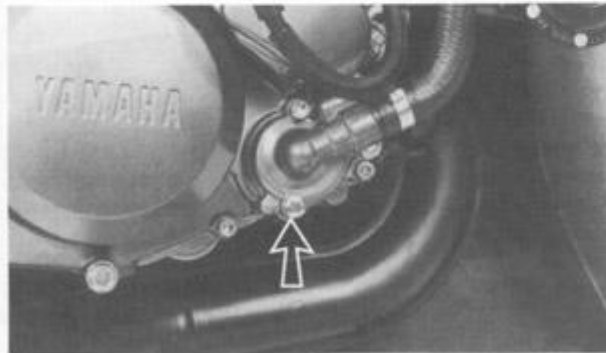

Drain bolt.

12. Fill the reservoir tank with coolant up to «FULL» level.
13. Reinstall the reservoir tank cap and check for coolant leakage.
14. Reassemble the two side panels of the fairing.

**NOTE:** \_\_\_\_\_  
If you find any leaks, ask a Yamaha dealer to inspect.

Recommended coolant:  
High quality ethylene glycol anti-freeze containing corrosion inhibitors for aluminium engines.  
Coolant and water mixed ratio:  
50% / 50%  
Total amount:  
1.10 L (0.9 Imp qt, 1.14 US qt)  
Reservoir tank capacity:  
0.33 L (0.30 Imp qt, 0.35 US qt)  
From LOW to FULL level  
0.24 L (0.21 Imp qt, 0.25 US qt)

**CAUTION:** \_\_\_\_\_  
Hard water or salt water is harmful to the engine. You may use distilled water if you can't get soft water.

### Air filter

1. Remove the rider seat following the instructions on page 19.
2. Remove the three screws fastening the tank to the frame (2 rear, 1 front).
3. Raise the tank and close the two petrol taps on the lower side by turning in a clockwise direction.
4. Detach the two petrol hoses from the taps and the breather hose, being careful not to let the fuel drip onto the fairings (as it might corrode them): remove the tank.
5. Remove the 5 fastening screws from the filter casing and raise the cover.

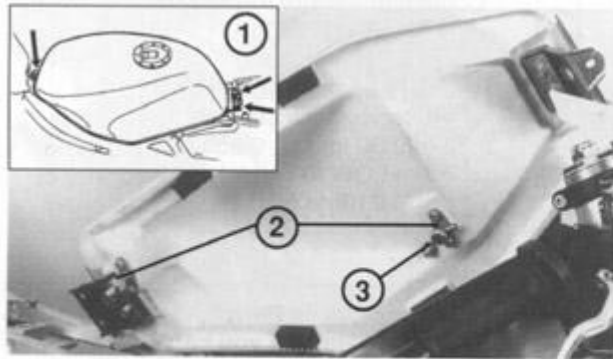

1. Tank fastening screws - 2. Petrol taps - 3. Breather

6. Remove the element from its case, and clean it with solvent. After cleaning, remove the remaining solvent by squeezing the element.
7. Apply recommended oil to the entire surface of the filter and squeeze out the excess oil. The element should be wet but not dripping.

Recommended oil:  
Foam-air-filter oil or  
SAE 10W30 motor oil

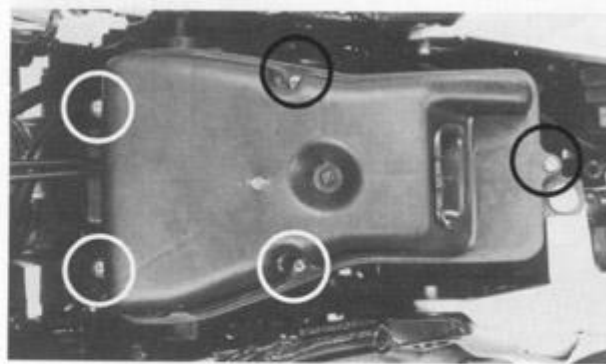

Filter casing fastening screws

8. When installing the element in its case, be sure its sealing surface matches the sealing surface of the case so there is no air leak.
9. Reassemble all the components, inverting the order of the operations described above.
10. The element should be cleaned at the specified intervals. It should be cleaned more often if the motorcycle is operated in dusty or wet areas.

**CAUTION:** \_\_\_\_\_

The engine should never be run without the air cleaner element; excessive piston and/or cylinder wear may result.

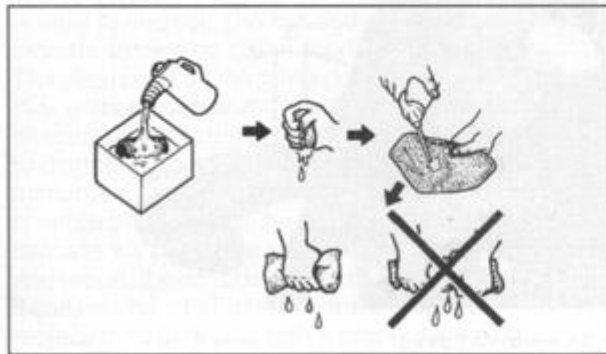

**Carburetor adjustment**

The carburetor is a vital part of the engine and requires very sophisticated adjustment. Most adjustments should be left to a Yamaha dealer who has the professional knowledge and experience to do so. However, the following point may be serviced by the owner as part of this routine maintenance.

**CAUTION:** \_\_\_\_\_

The carburetor was set at the Yamaha factory after many tests. If the settings are disturbed, poor engine performance and damage may result.

**Idle speed adjustment**

The minimum speed of the carburetor is set directly by the manufacturer and cannot be varied. It is, however, possible to vary the position of the throttle valve. To make this adjustment, proceed as follows:

1. Start the engine and warm it up for a few minutes (normally, 1 or 2 minutes) at approximately 1,000 to 2,000 r/min. Occasionally rev the engine to 4,000 to 5,000 r/min.  
The engine is warm when it quickly responds to the throttle.

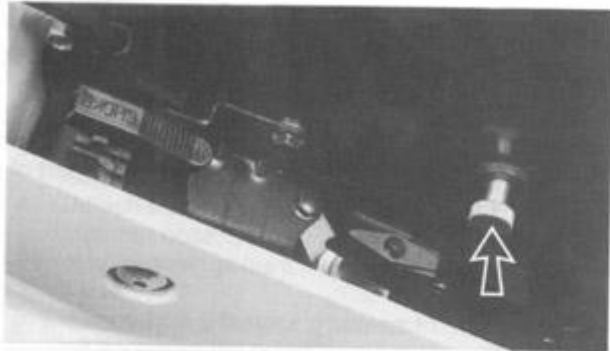

Gas valve opening adjustment knob.

2. Adjust the gas valve (accelerator) turning the knob right to increase it and left to decrease it.

Standard idle speed:  
1,200–1,300 r/min

**NOTE:**

If the specified idle speed cannot be obtained by performing the above adjustment, consult a Yamaha dealer.

**Throttle cable adjustment**

**NOTE:**

Before adjusting the throttle cable free play, the engine idling speed should be adjusted.

The accelerator cable must be set to the driver's preferences within the value specified.

Set as follows:

1. Remove the protective cap.
2. Remove the lock nut.
3. Unscrew or screw the adjustment device until you obtain the desired clearance.
4. Tighten the lock nut once more and replace the cap.

If you are unable to obtain a clearance setting within the prescribed values, consult a Yamaha dealer.

Free play:  
3–5 mm (0.12–0.20 in)

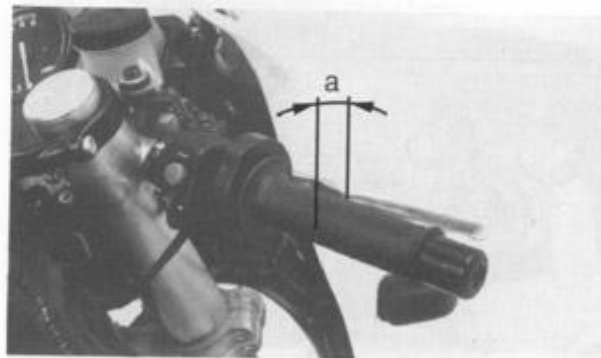

a. 3–5 mm (0.12–0.20 in).

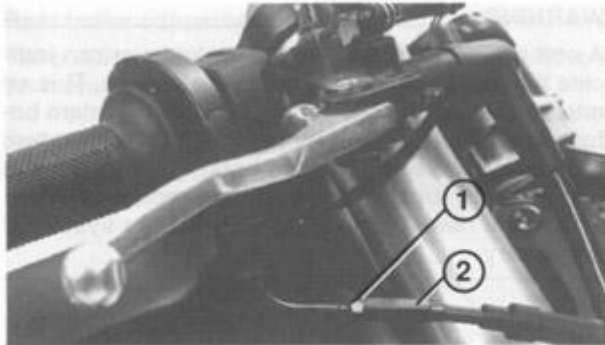

1. Lock nut - 2. Adjuster

### Spark plug inspection

The spark plug is an important engine component and is easy to inspect. The condition of the spark plug can indicate something of the condition of the engine.

The ideal color on the white porcelain insulator around the center electrode is a medium to light tan color for a motorcycle that is being ridden normally. Do not attempt to diagnose any problems yourself. Instead, take the motorcycle to a Yamaha dealer. You should periodically remove and inspect the spark plug because heat and deposits will cause the spark plug to slowly break down and erode. If electrode erosion becomes excessive, or if carbon and other deposits are excessive, you should replace the spark plug with a proper type plug.

Standard spark plug:  
W2CC (BOSCH) - BR9ES (NGK)

To approach the spark plug remove the right side panel of the fairing following the instructions on page 21. Before installing the spark plug, measure the electrode gap with a wire thickness gauge; adjust the gap to specification as necessary.

Spark plug gap:  
0.7-0.8 mm (0.028-0.031 in)

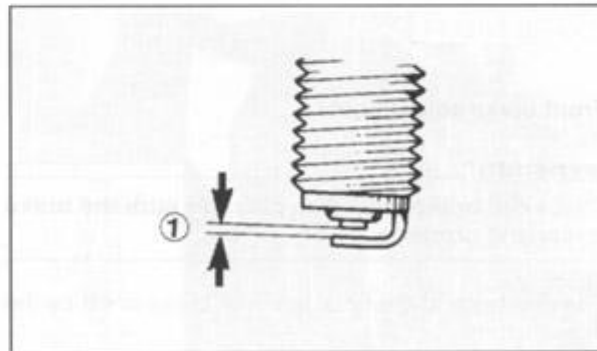

1. Electrode gap

When installing the plug, always clean the gasket surface and use a new gasket. Wipe off any grime from the threads, and torque the spark plug properly.

Spark plug torque:  
20 Nm (2.0 mkg, 14 ft-lb)

**NOTE:**

If a torque wrench is not available when you are installing a spark plug, a good estimate of the correct torque is 1/4 to 1/2 turns past finger tight. Have the spark plug torqued to the correct value as soon as possible with a torque wrench.

**Front brake adjustment**

**WARNING:**

Check the brake lever free play. Be sure the brake is working properly.

The clearance at the tip of the front brake is set by the manufacturer.

If a new setting were to prove necessary, adjust the appropriate screw.

**WARNING:**

A soft or spongy feeling in the brake lever can indicate the presence of air in the brake system. This air must be removed by bleeding the brake system before the motorcycle is operated. Air in the system will cause greatly diminished braking capability and can result in loss of control and an accident. Have a Yamaha dealer inspect and bleed the system if necessary.



Adjustment screw

### Rear brake adjustment

The position of the upper tip of the brake pedal is set by the manufacturer.

If a new setting were to prove necessary, adjust the brake rod (1) behind the brake pedal.

The brake pedal can be further adjusted by moving the adjustment eccentric (2).

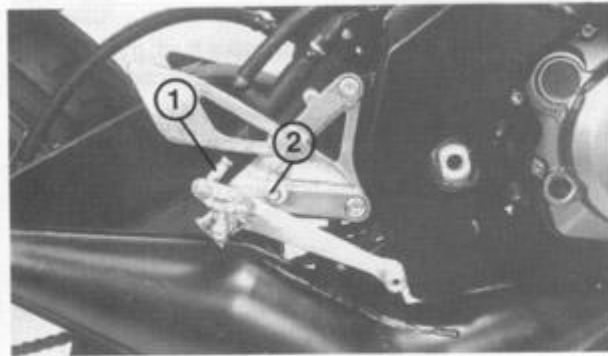

1. Adjustment brake rod - 2. Adjustment eccentric

### WARNING:

An incorrect free play indicates a hazardous condition in the brake system. Do not operate the motorcycle until the failure in the brake system is corrected. Ask a Yamaha dealer for immediate repairs.

### Checking the front and rear brake pads

Check the brake pads for damage and wear. If the thickness is less than the specified value, have a Yamaha dealer replace the pads.

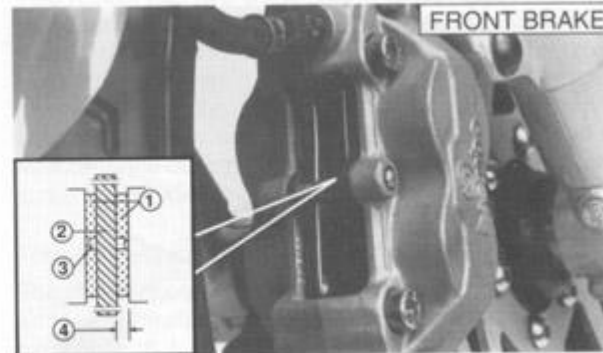

1. Pads - 2. Disc - 3. Wear gauge - 4. Limit of wear 0.8 mm (0.031 in)

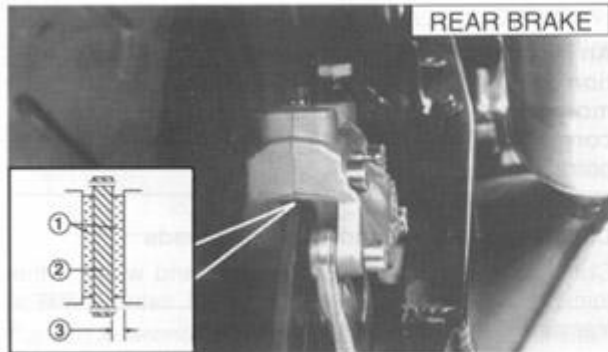

1. Pads - 2. Disc - 3. Limit of wear 0.8 mm (0.031 in)

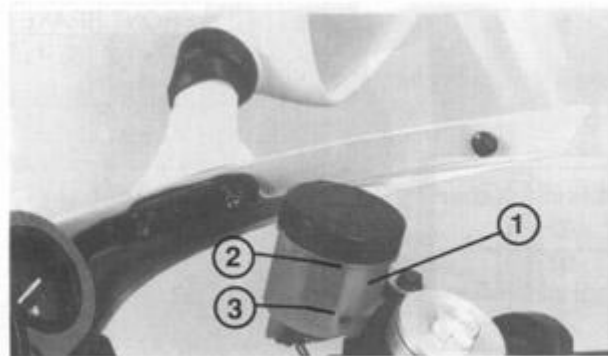

1. Front brake oil tank - 2. Minimum level - 3. Maximum level

### Inspecting the brake fluid level

Insufficient brake fluid may let air enter the brake system possibly causing the brakes to become ineffective.

Before riding, check the brake fluid level and replenish when necessary: observe these precautions:

1. When checking the fluid level, make sure the master cylinder top is horizontal by turning the handle bars.
2. Use only the designated quality brake fluid; otherwise, the rubber seals may deteriorate, causing leakage and poor brake performance.

Recommended brake fluids: DOT # 4.  
If DOT # 4 is not available,  
# 3 can be used.

3. Refill with the same type of brake fluid; mixing fluids may result in a harmful chemical reaction and lead to poor performance.
4. Be careful that water does not enter the master cylinder when refilling. Water will significantly lower the boiling point of the fluid and may result in vapor lock.



5. Brake fluid may erode painted surfaces or plastic parts. Always clean up spilled fluid immediately.
6. Have a Yamaha dealer check the cause if the brake fluid level goes down.

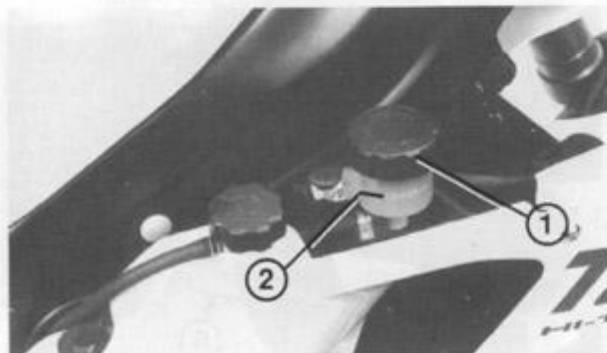

1. Rear brake oil tank - 2. Minimum level

#### Brake fluid replacement

1. Complete fluid replacement should be done only by trained Yamaha service personnel.

2. Have a Yamaha dealer replace the following components when indicated in the schedule or when they are damaged or leaking.
  - a. Replace all rubber seals every two years.
  - b. Replace all hoses every four years.

#### Clutch adjustment

This model has two clutch cable length adjusters. The cable length adjusters are used to take up slack from cable stretch and to provide sufficient free play for proper clutch operation.

Normally, once the clutch cable length adjuster (crankcase) is properly set; the only adjustment required is maintenance of free play at the clutch cable length adjuster (handlebar lever).

#### Free play adjustment

The clutch should be adjusted to suit the rider's preference, but free play at the lever end should be 10–15 mm (0.4–0.6 in). Loosen either the handlebar lever adjuster lock nut or the cable length adjuster lock nut.

Turn the cable length adjuster either in or out until proper lever free play is achieved.

Clutch lever free play:  
10~15 mm (0.4~0.6 in)

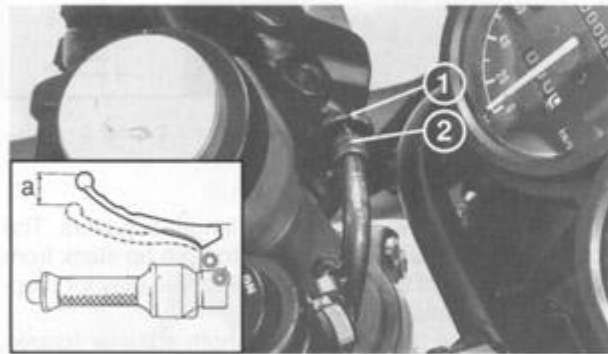

1. Locking nut - 2. Adjuster - a. Free play

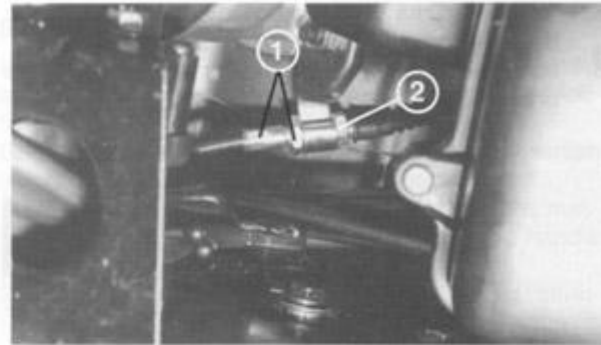

1. Adjustment device - 2. Lock nut

#### Drive chain slack check

##### NOTE :

Before checking and/or adjusting the chain slack, rotate the rear wheel through several revolutions. Check the chain slack several times to find the point where the chain is the tightest. Check and/or adjust the chain slack where the rear wheel is in this «tight chain» position.

To check the chain slack the motorcycle must stand vertically with its both wheels on the ground and without a rider.

Check the slack at the position shown in the illustration. The normal vertical deflection is approximately 25–40 mm (1.0–1.6 in). If the deflection exceeds 40 mm (1.6 in) adjust the chain slack.

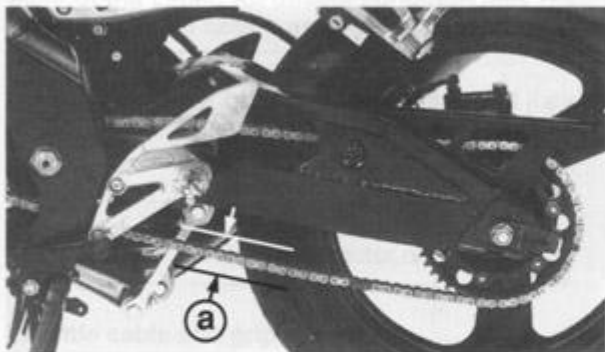

a. 25-40mm (1.0-1.6 in)

#### Drive chain slack adjustment

1. Unscrew the wheel axle nut (1).
2. Loosen the lock nuts (2) on either side of the chain stretchers.
3. Adjust the chain to the prescribed tension with the chain stretcher screws (3): screw to stretch and unscrew to loosen.

4. Tighten the lock nuts (2) once more and tighten the wheel axle nut (1) to the required torque. Set the two chain stretchers to the same measurement to centre the wheel correctly.

Axle nut torque:  
80 Nm (8.0 m·kg, 58 ft·lb)

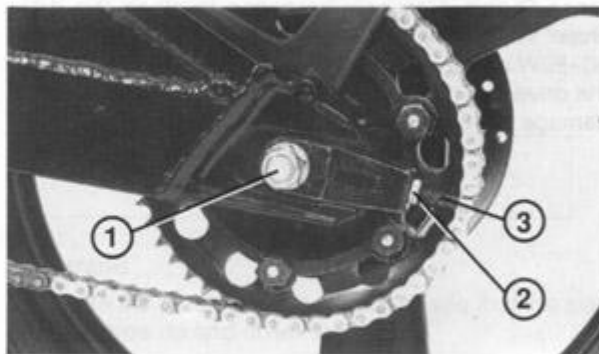

1. Wheel axle nut - 2. Lock nut - 3. Stretcher

#### CAUTION:

Too small chain slack will overload the engine and other vital parts; keep the slack within the specified limits.

### Drive chain lubrication

The chain consists of many parts which work against each other. If the chain is not maintained properly, it will wear out rapidly, therefore, form the habit of periodically servicing the chain. This service is especially necessary when riding in dusty conditions.

This motorcycle has a drive chain with small rubber O-rings between the chain plates. Steam cleaning, high-pressure washes, and certain solvent can damage these O-ring. Use only kerosene to clean the drive chain. Wipe it dry, and thoroughly lubricate it with SAE 30-50W motor oil. Do not use any other lubricants on the drive chain. They may contain solvents that could damage the O-rings.



#### NOTE

Do not use steam cleaning, high-pressure washes, or solvents to clean the drive chain. Use only kerosene to clean the drive chain. Wipe it dry, and thoroughly lubricate it with SAE 30-50W motor oil. Do not use any other lubricants on the drive chain. They may contain solvents that could damage the O-rings.

### Cable inspection and lubrication

**WARNING:** \_\_\_\_\_

Damage to the outer housing of the various cables may cause corrosion and interfere with the movement of the cable. An unsafe condition may result so replace such cables as soon as possible.

Lubricate the inner cable and the cable end. If they do not operate smoothly, ask a Yamaha dealer to replace them.

Recommended lubricant:  
SAE 10W30 motor oil

### Throttle cable and grip lubrication

The throttle twist grip assembly should be greased at the time that the cable is lubricated, since the grip must be removed to get at the end of the throttle cable. Two screws clamp the throttle housing to the handlebar. Once these two are removed, the end of the cable can be held high to pour in several drops of lubricant. With the throttle grip disassembled, coat the metal surface of the grip assembly with a suitable all-purpose grease.

### Autolube pump adjustment

The Autolube pump is a vital part of the engine and requires very sophisticated adjustment. Most adjusting

should be left to a Yamaha dealer who has the professional knowledge and experience to do so.

### Brake and change pedals

Lubricate the pivoting parts.

Recommended lubricant:  
SAE 10W30 motor oil

### Brake and clutch levers

Lubricate the pivoting parts.

Recommended lubricant:  
SAE 10W30 motor oil

### Sidestand

Lubricate the pivoting parts. Check to see that the side stand moves up and down smoothly.

Recommended lubricant:  
SAE 10W30 motor oil

**WARNING:** \_\_\_\_\_

**If the sidestand movement is not smooth, consult a Yamaha dealer.**

### Rear suspension

Lubricate the pivoting parts.

Recommended lubricant:  
Lithium soap base grease

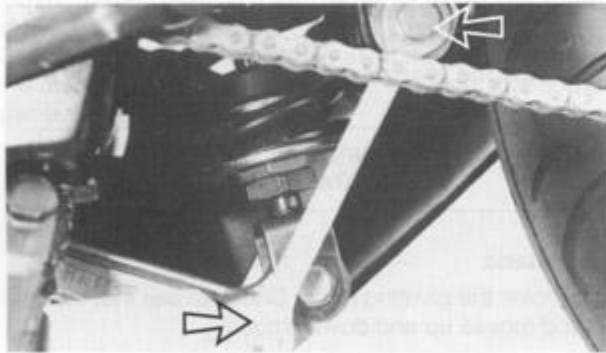

### Front fork inspection

**WARNING:**

Securely support the motorcycle so there is no danger of it falling over.

1. Visual check:  
Check any scratch/damage on the inner tube and excessive oil leakage with the front fork.

**NOTE:**

If any oil leakage or damage is found, consult a Yamaha dealer.

2. Operation check:  
Place the motorcycle on a level place.
  - a. Hold the motorcycle on an upright position with a rider's hands on the handlebar and apply the front brake.
  - b. Pump the front fork up and down for several times.

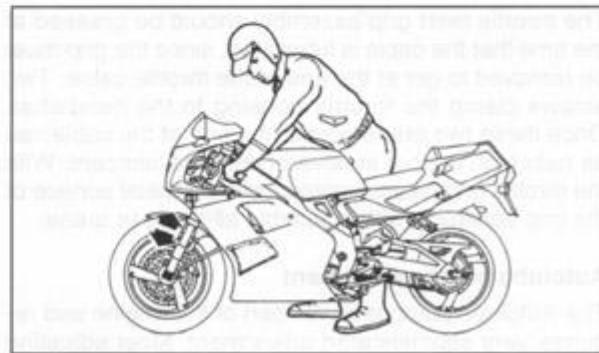

**NOTE:** \_\_\_\_\_

If any damage or unsmooth movement is found with the front fork, consult a Yamaha dealer.

---

**Rear shock  
(Monocross suspension system)**

**WARNING:** \_\_\_\_\_

This shock absorber contains highly pressurized nitrogen gas. Read and understand the following information before handling the shock absorber. The manufacturer cannot be held responsible for property damage or personal injury that may result from improper handling.

1. Do not tamper with or attempt to open the cylinder assembly.
  2. Do not subject shock absorber to an open flame or other high heat source. This may cause the unit to explode due to excessive gas pressure.
  3. Do not deform or damage the cylinder in any way. Cylinder damage will result in poor damping performance.
  4. Bring your shock absorber to a Yamaha dealer for any service.
- 

**Rear shock absorber adjustment**

The preload is adjusted by changing the set length of the spring: a shorter set length increases the preload, a longer set length decreases the preload.

1. To adjust the preload, loosen the lock nut.
2. Adjust the spring set length by turning the spring adjuster with the special wrench.
3. To increase the preload, turn the spring adjuster clockwise. To decrease the preload, turn the spring adjuster counterclockwise. One complete turn of the adjuster will change the preload 1 mm (0.04 in). Make changes in increments of 2 mm (0.08 in) at a time.

Standard length (installed): 167 mm (6.6 in)
Minimum length (installed): 164 mm (6.5 in)
Maximum length (installed): 176 mm (6.9 in)

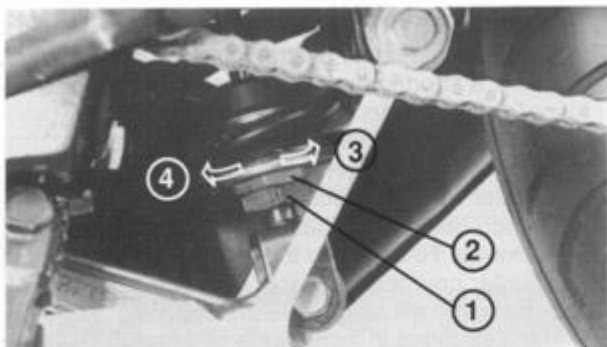

1. Lock nut. - 2. Adjuster. - 3. Increase spring preload. - 4. Decrease spring preload.



Adjustment key

**CAUTION:** \_\_\_\_\_  
 Never attempt to turn the adjuster beyond the maximum or minimum setting.  
 \_\_\_\_\_

**NOTE:**

Tightening torque:  
 22 Nm (2.2 m·kg, 16 ft·lb)

**CAUTION:** \_\_\_\_\_  
 Always tighten the lock nut against the spring adjuster and torque the lock nut to specification.  
 \_\_\_\_\_



### Steering inspection

Periodically inspect the condition of the steering. Worn out or loose steering bearings may be dangerous.

Place a block under the engine to raise the front wheel off the ground.

Hold the lower end of the front forks and try to move them forward and backward. If any free play can be felt, ask a Yamaha dealer to inspect and adjust the steering.

### WARNING:

Securely support the motorcycle so there is no danger of it falling over.

### Wheel bearings

If the wheel bearings in the front or rear wheel allow play in the wheel hub or if the wheel does not turn smoothly, have a Yamaha dealer inspect the wheel bearings. The wheel bearings should be inspected according to the Maintenance Schedule.

### Checking the battery liquid level

Remove the right side panel (1) of the rear cowling after first removing the fastening screw (2), releasing it from the rear notches. Check the level of the electrolyte and check that the clamps are well tightened. If necessary, top up with distilled water.

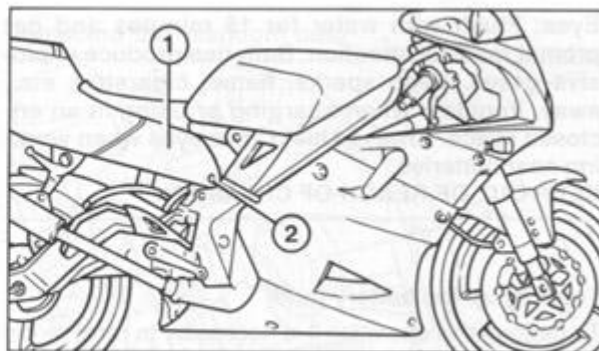

1. Battery case panel - 2. Panel fastening screw

### CAUTION:

When inspecting the battery, be sure the breather pipe is routed correctly. If the breather pipe touches the frame or exits in such a way as to cause battery electrolyte or gas to exit onto the frame, structural and cosmetic damage to the motorcycle can occur.

### WARNING:

Battery electrolyte is poisonous and dangerous, causing severe burns, etc. It contains sulfuric acid.

Avoid contact with skin, eyes or clothing.

Antidote: EXTERNAL - Flush with water.

INTERNAL - Drink large quantities of water or milk. Follow with milk of magnesia, beaten egg, or vegetable oil. Call a physician immediately.

**Eyes:** Flush with water for 15 minutes and get prompt medical attention. Batteries produce explosive gases. Keep sparks, flame, cigarettes etc., away. Ventilate when charging or using in an enclosed space. Always shield your eyes when working near batteries.

**KEEP OUT OF REACH OF CHILDREN.**

### Topping up the battery fluid

To perform this operation it is necessary to remove the right side panel of the fairing (see previous page) and release the elastic battery fastening belt.

A poorly maintained battery deteriorates rapidly. The level of the electrolyte must be checked at least once a month.

1. The level should be situated between the upper and lower level marks. To top up the level use only distilled water.

### CAUTION:

Normal tap water contains minerals which are harmful to a battery: therefore, refill only with distilled water.

### WARNING:

Battery fluid on the chain can cause premature failure and possibly an accident.

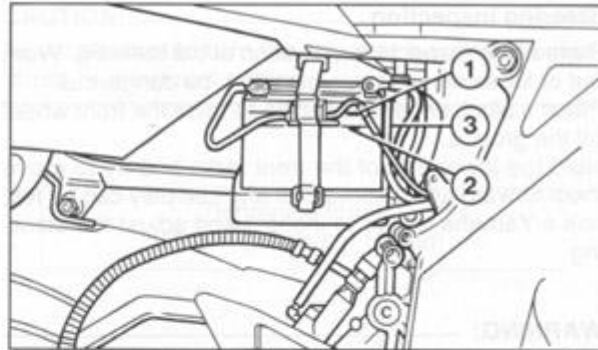

1. Maximum level - 2. Minimum level - 3. Battery breather hose

2. When the motorcycle will not be used for a month or longer, remove the battery and store it in a cool, dark place. Completely recharge the battery before reusing.
3. If the battery will be stored for a longer period than the above, check the specific gravity of the fluid at least once a month and recharge the battery when it is too low.
4. Always make sure the connections are correct when putting the battery back in the motorcycle. Make sure the breather pipe is properly connected and is not damaged or obstructed.

### Fuse replacement

If a fuse is blown, turn off the ignition switch and the switch in the circuit in question. Install a new fuse of proper amperage.

Turn on the switches, and see if the electrical device operates. If the fuse immediately blows again, consult a Yamaha dealer.

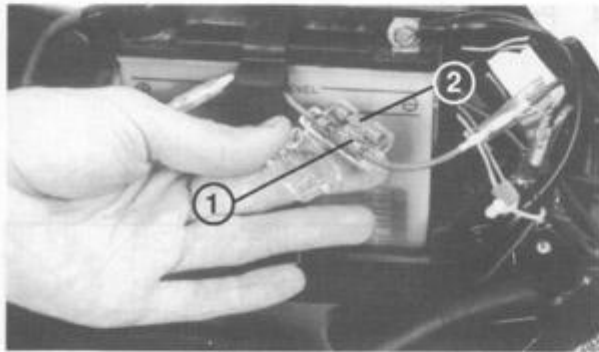

1. Fuse - 2. Spare fuse

### CAUTION :

Do not use fuses of higher amperage rating than those recommended. Substitution of a fuse of improper rating can cause extensive electrical system damage and possibly a fire.

### Replacing the headlight bulb

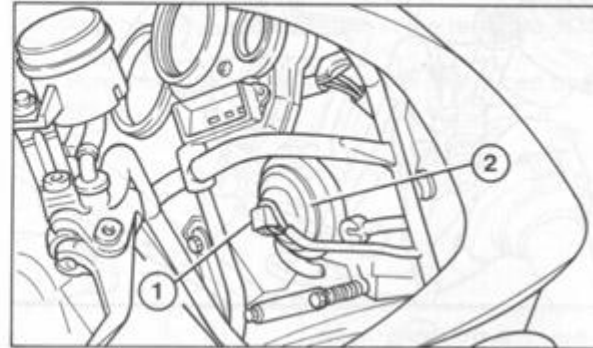

1. Connector - 2. Protection

The headlight on this motorcycle is fitted with a halogen bulb. To change the bulb, follow the following instructions:

1. Approach the light from behind the front cowling.
2. Detach the connector and remove the protection.
3. Turn the ring nut in an anticlockwise direction and remove it together with the bulb.
4. Change the bulb.
5. Place the new bulb in the correct position and lock it by turning the ring nut in a clockwise direction.
6. Replace the protection and reattach the connector.

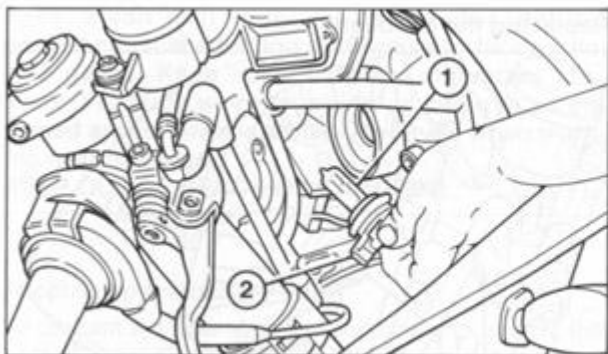

1. Bulb - 2. Bulb fastening ring nut

**WARNING:**

Keep flammable products or your hands away from the bulb while it is on, it will be hot. Do not touch the bulb until it cools down.

**Replacing the front parking light bulb**

The parking light bulb is housed in the rear right-hand side of the headlight. To change it:

1. Press the bulb holder to make it pop out.
2. Turn and remove the damaged bulb.
3. Insert the new bulb.
4. Press the bulb holder back into place.

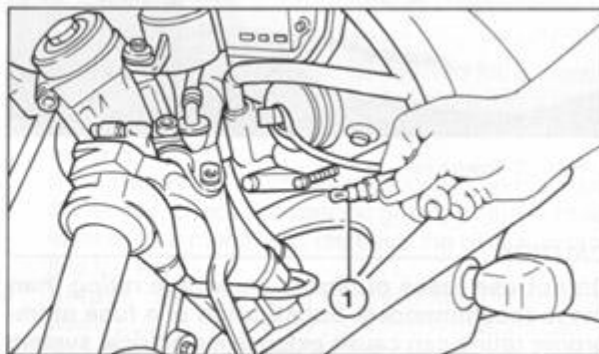

1. Bulb holder

### Vertical setting of the headlight beam

**NOTE:**

It is advisable to have this setting made by a Yamaha dealer.

To set the headlight beam, proceed as follows:

1. Approach the setting screw in the rear part of the headlight.
2. Screw or unscrew to obtain the prescribed beam height.



1. Vertical setting screw

### Front wheel removal

1. Place a suitable support under the engine and raise the front wheel. If overhead raising equipment is unavailable, it is necessary to disassemble the whole fairing to set the support in place.
2. Remove the cap and detach the odometer wire from the transmission (1).
3. Loosen the allen screws (2) which fix the wheel axle to the front fork.
4. Loosen the wheel axle (3) and remove.
5. Remove the wheel, making sure that the motorcycle is well supported.

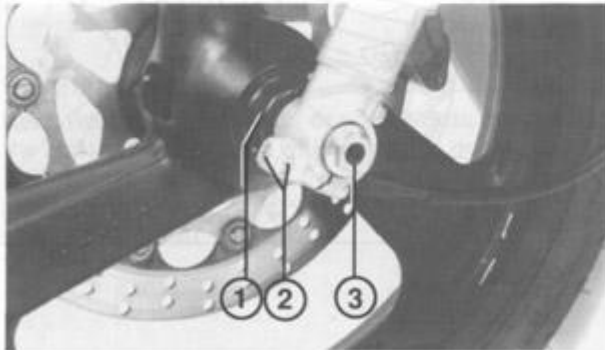

1. Odometer transmission - 2. Wheel axle fastening screws -  
3. Wheel axle

### Front wheel installation

To mount the front wheel, follow the removal instructions in inverted order.

Pay attention to the following points:

1. Check that the odometer transmission is in the correct position and that the wire is properly connected.
2. Be sure to tighten the wheel axle correctly.
3. Before retightening the wheel axle fastening screws to the fork, pump the fork repeatedly to check that it is working properly.

Tightening torques:	
Wheel axle:	70 Nm (7.0 m.kg, 50.0 ft•lb)
Wheel axle fastening screws:	10 Nm (1.0 m.kg, 7.2 ft•lb)

## Rear wheel removal

### WARNING:

It is advisable to have a Yamaha dealer service the rear wheel.

1. Place a suitable support under the engine and raise the front wheel.
2. Unscrew the wheel axle nut (1) and loosen the chain stretchers (2).
3. Push the wheel forwards and remove the chain.
4. Hold up the brake caliper support and remove the wheel axle, paying attention to the 2 spacers.
5. Detach the wheel unit.

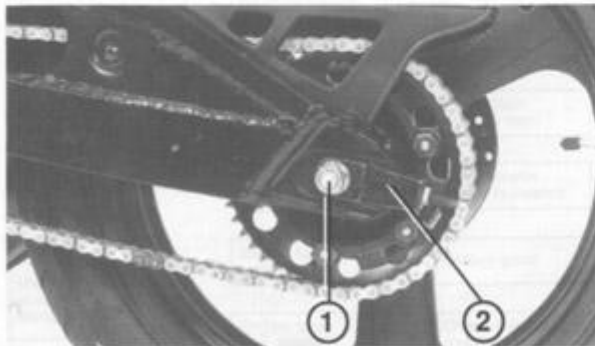

1. Wheel axle nut - 2. Chain stretcher

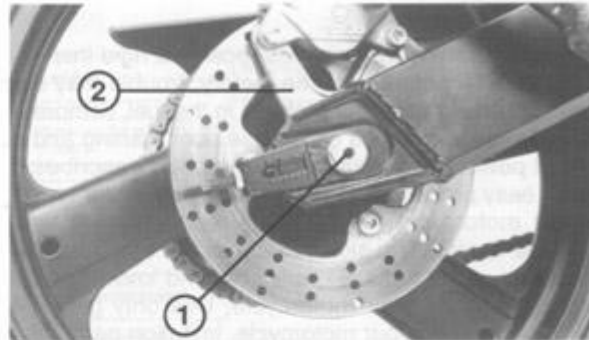

1. Wheel axle - 2. Brake caliper support

## Rear wheel installation

To mount the rear wheel, follow the removal instructions in inverted order.

Pay attention to the following points:

1. Check that the chain stretchers are installed properly.
2. Adjust the tension of the transmission chain.
3. Check that the wheel axle nut is tightened to the prescribed torque.
4. Adjust the rear brake (see page 50).

Wheel axle nut tightening torque:  
80 Nm (8.0 m.kg, 58 ft•lb)

### Troubleshooting

Although Yamaha motorcycles receive a rigid inspection before shipment from the factory, trouble may occur during operation. Any problem in the fuel, compression or ignition systems can cause poor starting and a loss of power. The troubleshooting chart describes a quick, easy procedure for checking these systems.

If your motorcycle requires any repair bring it to a Yamaha dealer. The skilled technicians at a Yamaha dealer have the tools, experience, and know-how to properly service your motorcycle. Use only genuine Yamaha parts on your motorcycle. Imitation parts may look like Yamaha parts, but they are often inferior. Consequently, they have a shorter service life and can lead to expensive repair bills.





## Troubleshooting chart

### WARNING

Never check the fuel system while smoking or in the vicinity of an open flame.

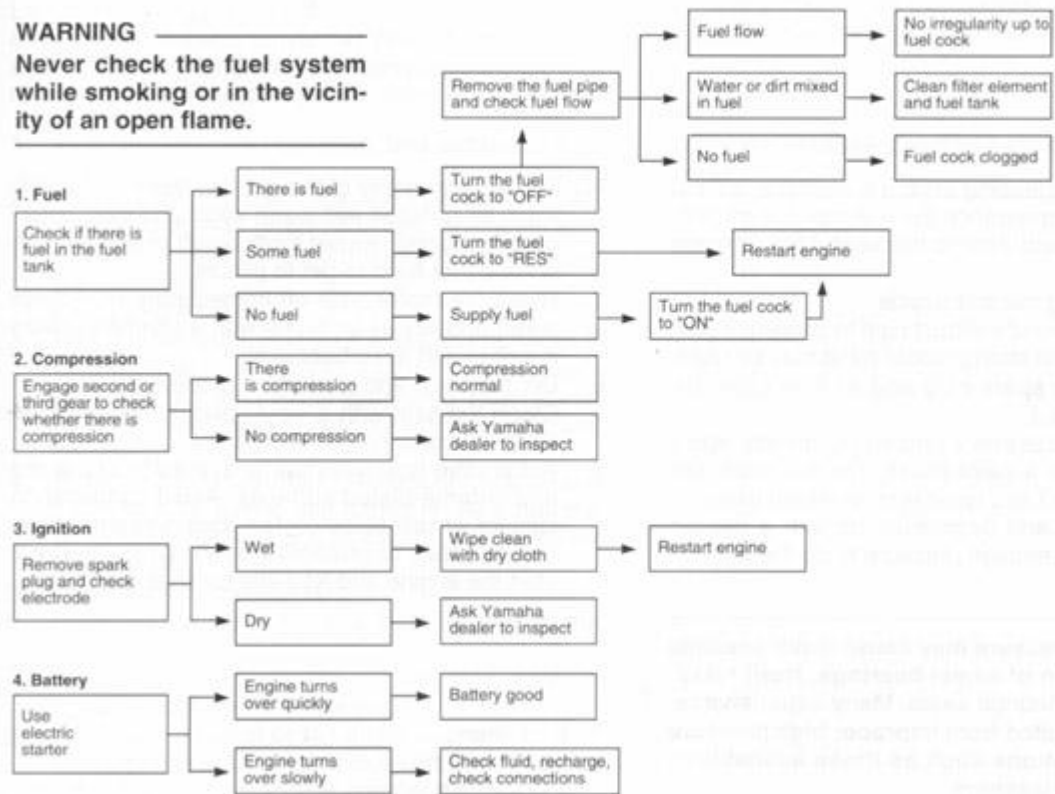

## CLEANING AND STORAGE

### A. CLEANING

Frequent thorough cleaning of your motorcycle will not only enhance its appearance but will improve its general performance and extend the useful life of many components.

1. Before cleaning the motorcycle:
  - a. Block off the end of exhaust pipe to prevent water: a plastic bag and strong rubber band may be used.
  - b. Make sure the spark plug and all filler caps are properly installed.
2. If the engine case is excessively greasy apply degreaser with a paint brush. Do not apply degreaser to the chain, sprockets, or wheel axles.
3. Rinse the dirt and degreaser off with a garden hose, use only enough pressure to do the job.

#### CAUTION:

Excessive hose pressure may cause water seepage and contamination of wheel bearings, front forks, brakes and transmission seals. Many expensive repair bills have resulted from improper high pressure detergent applications such as those available in coin-operated car washers.

4. Once the majority of the dirt has been hosed off, wash all surfaces with warm water and mild, detergent-type soap. An old tooth brush or bottle brush is handy for hard-to-get-to places.
5. Rinse the motorcycle off immediately with clean water and dry all surfaces with a chamois, clean towel, or soft absorbent cloth.
6. Dry the chain and lubricate it to prevent rust.
7. Clean the seat with a vinyl upholstery cleaner to keep the cover pliable and glossy.
8. Automotive-type wax may be applied to all painted and chrome-plated surfaces. Avoid combination cleaner-waxes. Many contain abrasives which may mar the paint or protective finish. When finished, start the engine and let it idle for several minutes.

## B. STORAGE

Long term storage (60 days or more) of your motorcycle will require some preventive procedures to guard against deterioration. After thoroughly cleaning the motorcycle, prepare for storage as follows:

1. Drain the fuel tank, fuel lines, and carburetor float bowl.
2. Remove empty fuel tank, pour a cup of SAE 10W30 or 20W40 motor oil in tank, shake the tank to coat the inner surfaces thoroughly and drain off the excess oil.  
Reinstall the tank.
3. Remove the spark plug pour about one tablespoon of SAE 10W30 or 20W40 motor oil in the spark plug hole and reinstall the spark plug. Push starter switch several times to coat the cylinder walls with oil.
4. Remove the drive chain. Thoroughly clean the chain with kerosene and lubricate. Reinstall the chain or store it in a plastic bag (tied to frame for safe-keeping).
5. Lubricate all control cables.
6. Block up the frame to raise both wheels off the ground.
7. Tie a plastic bag over the exhaust pipe outlet to prevent moisture from entering.
8. If storing in a humid or salt-air atmosphere, coat all exposed metal surfaces with a light film of oil. Do not apply oil to any rubber parts or the seat cover.
9. Remove the battery and charge it. Store it in a dry

place and recharge it once a month. Do not store the battery in an excessively warm or cold place (less than 0°C (30°F) or more than 30°C (90°F).

**NOTE:** \_\_\_\_\_  
Make any necessary repairs before storing the motorcycle).  
\_\_\_\_\_

## SPECIFICATIONS

Model	TZR 125RR
Dimension:	
Overall length	2,025 mm (79.7 in)
Overall width	740 mm (29.1 in)
Overall height	1,110 mm (43.7 in)
Seat height	790 mm (31.1 in)
Wheel base	1,400 mm (55.1 in)
Minimum ground clearance	150 mm (5.9 in)
Basic weight:	
With oil and full fuel tank	133 kg (60.2 lbs)
Minimum turning radius:	3,005 mm (118.3 in) left; 3,025 mm (119.1 in) right
Engine:	
Type	Liquid cooled, 2-stroke, gasoline
Model	4DL1
Cylinder arrangement	Single cylinder, forward inclined
Displacement	124.8 c.c.
Bore x Stroke	56.0 x 50,68 mm (2.20 x 2.00 in)
Compression ratio	12.8 : 1
Starting system	Electric starter
Lubrication system	Separate lubrication (Yamaha Autolube)

Model	TZR 125RR
Engine oil (2-cycle): Type Capacity	Separate lube 2-stroke engine oil SHELL 2TX 1.4 L (1.3 Imp qt, 1.5 US qt)
Transmission oil: Type Capacity Periodic oil change Total amount	SAE 10W30 type SE motor oil 0.75 L (0.66 Imp qt, 0.79 US qt) 0.80 L (0.7 Imp qt, 0.9 US qt)
Radiator capacity: (Including all routes)	1.280 L (1.13 Imp qt)
Air filter:	Wet type element
Fuel: Type Tank capacity Reserve amount	Premium gasoline For Switzerland: UNLEADED PETROL ONLY 13 L (2.86 Imp gal) 2 L (0.45 Imp gal)
Carburetor: Type/manufacturer	VHSA 32 GS Dell'Orto
Spark plug: Type/manufacturer Gap	BR9ES/NGK - W2CC/BOSCH 0.7-0.8 mm (0.028-0.031 in)
Clutch type:	Wet, multi-disc

Model	TZR 125RR
Transmission: Primary reduction system Primary reduction ratio Secondary reduction system Secondary reduction ratio Transmission type Operation Gear ratio 1st 2nd 3rd 4th 5th 6th	Helical gear 73/22 (3.318) Chain drive 51/18 (2.833) Constant mesh 6-speed Left foot operation  34/12 (2.833) 29/16 (1.813) 26/19 (1.368) 24/21 (1.143) 23/23 (1) 22/24 (0.917)
Chassis: Frame type Caster angle Trail	Single cradle 25°±30' 96.5 mm (3.799 in)
Tire: Type Size - Front  Rear	Tubeless 110/70 - TR17" SPORTMAX TL DUNLOP or 110/70 (or 120/60) - ZR17" MP7 PIRELLI 140/70 - TR17" SPORTMAX TL DUNLOP or 150/60 - ZR17" MP7 PIRELLI
Brake: Front brake type Operation Rear brake type Operation	Single, disk brake Right hand operation Single, disk brake Right foot operation

Model	TZR 125RR
Suspension: Front Rear	Telescopic fork (upside down) dia. 41 mm (1.614 in) Swing arm (Monocross suspension)
Shock absorber: Front Rear	Helical spring, oil damper Gas, helical spring, oil damper
Wheel travel Front Rear	120 mm (4.72 in) 115 mm (4.52 in)
Electrical: Ignition system Generator system Battery type/capacity Fuse	CDI magneto Flywheel magneto GM6-4B/12V-6AH 10A
Headlight type:	Bulb
Bulb wattage/quantity: Headlight Tail/brake light Flasher light Auxiliary light Meter light	12V-60/55W x 1 12V-21/5W x 1 12V-10W x 4 12V-5W x 2 12V-1.7W x 3 - 12V-1,7W x 1
Indicator light wattage/quantity: «NEUTRAL» «HIGH BEAM» «OIL LEVEL» «TURN»	12V-3.4W 12V-3.4W 12V-3.4W 12V-3.4W

# WIRING DIAGRAM

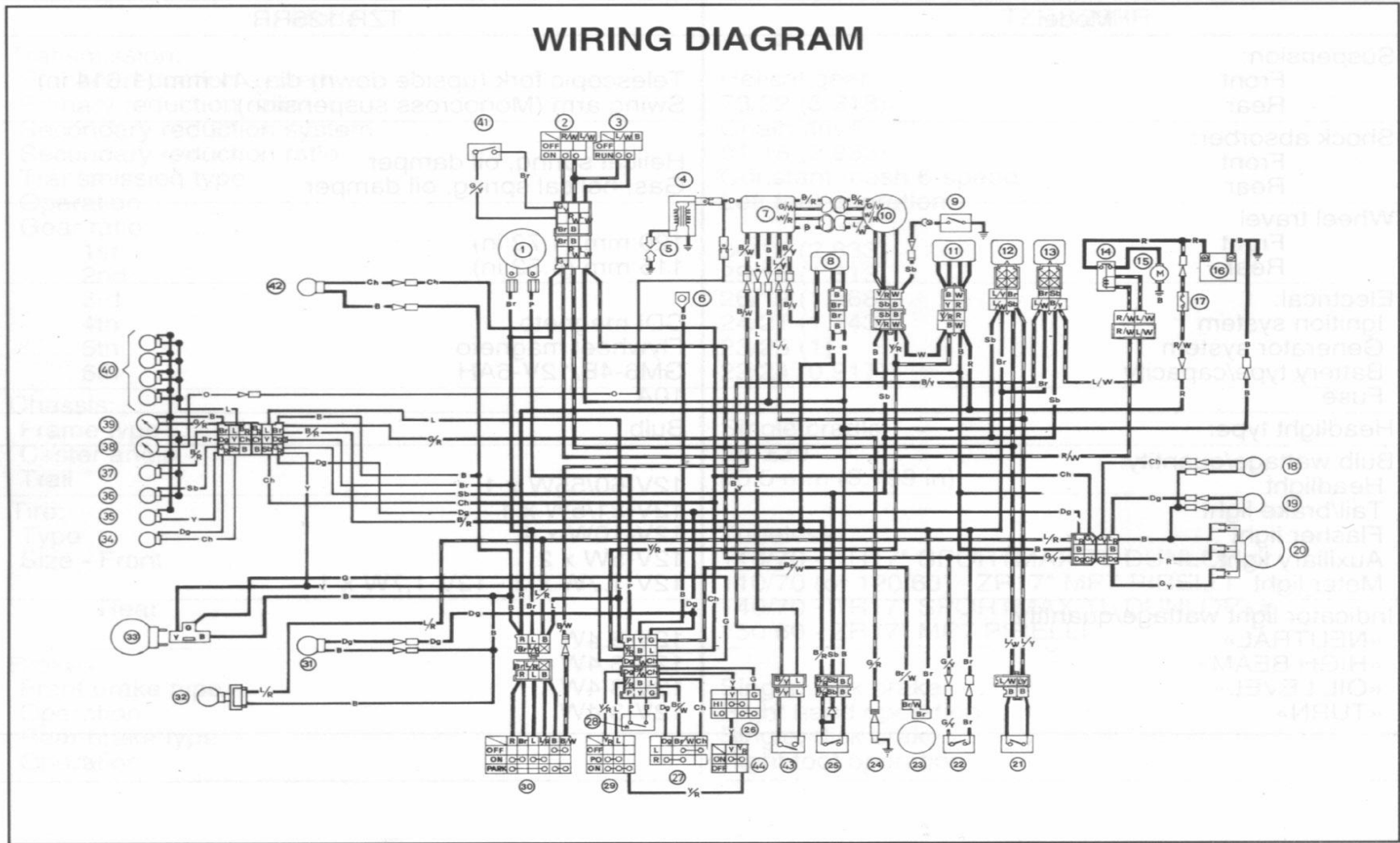



1. Horn
2. Engine start switch
3. Engine «STOP» switch
4. Ignition coil
5. Spark plug
6. Brache eart
7. CDI Unit
8. YPVS
9. Neutral switch
10. D.D.I. Magneto
11. Rectifier/Regulator
12. Ignition switch relay
13. Engine starter switch relay
14. Starter relay
15. Starter
16. Battery
17. Fuse
18. Rear flasher light (R)
19. Rear flasher light (L)
20. Tail/brake light
21. Stand switch
22. Rear stop light switch
23. Flasher relay
24. Termo unit
25. Oil level switch
26. «LIGHTS» switch
27. «TURN» switch
28. «HORN» switch
29. «LIGHTS»

30. Main switch
31. Front flasher light (L)
32. Ausiliary light
33. Headlight
34. «TURN»
35. «HIGH BEAM»
36. «NEUTRAL»
37. «OIL»
38. Tachimeter
39. Themperature gauge
40. Instruments light
41. Front brake switch
42. Front flasher light (R)
43. Clutch switch
44. Headlight flasher

#### COLOR CODE

- B - Black
- Br - Brown
- Ch - Chocolate
- Dg - Dark green
- G - Green
- L - Blue
- Gy - Gray
- O - Orange
- P - Pink
- R - Red
- Sb - Sky blue

- W - White
- Y - Yellow
- B/R - Black/Red
- B/W - Black/White
- L/W - Blue/White
- B/Y - Black Yellow
- Br/W - Brown/White
- L/R - Blue /Red
- G/Y - Green/Yellow
- R/W - Red/White
- Y/R - Yellow/Red