

Table of Contents

Contents	6
Chapter 1- General	8
Profile	103
Features	10
Specifications	11
Performance Curves	21
Tools and Instruments for Shop Service	24
Periodic Maintenance Intervals	26
Lubrication Intervals	27
Chapter 2. Yamaha Autolube	28
What is Yamaha Autolube	28
Features of Yamaha Autolube	28
Handling the Oil Pump	29
Chapter 3. Cylinder Porting	34
Description of 5 Port Cylinder	34
Construction and Features	34
The Torque Induction System	37
The Yamaha Reed Valve	38
Operation of the Torque Induction System	39
Chapter 4. Engine	44
Engine Removal	44
Cylinder Head	50
Cylinder	51
Piston Pin	53
Piston Ring	54
Piston	56
Crankcase Cover (R.H)	58
Clutch	60
Primary Drive Gear	65
Kick Starter Mechanism	66
Shift Mechanism	69
Drive Sprocket	71
Crankcase	73
Transmission Assembly	74
Crankshaft	78
Bearings and Oil Seals	81
Carburetor	82
Air Cleaner	86
Chapter 5. Chassis	87
Front Wheel	87

Rear Wheel	92
Rear Wheel Sprocket	97
Tires and Tubes	98
Front Forks	98
Rear Shocks	102
Gas Tank	103
Rear Swing Arm	105
Steering Head	107
Oil Tank, Battery Box and Tool Box	108
Frame	108
Handlebars	108
Miscellaneous	108
Chapter 6. Electrical System for LT Series	109
Description	109
Table of Component Parts	109
Connection Diagram	109
Ignition System—Function and Service	109
Ignition Timing	110
Ignition Coil	110
Condenser	111
Charging System	111
Battery	113
Checking the Main Switch (removed from the chassis)	114
Spark Plug	115
Lighting and Signal Systems	115
Chapter 7. Electrical System for AT Series	117
Description	117
Table of Component Parts	117
Main Components	118
Charging and Starting System	118
Connection Diagram	119
Starter Dynamo	120
Regulator (Voltage Regualtor)	128
Ignition Coil	130
Checking the Main Switch (removed from the chassis)	131
Chapter 8. Electrical System for CT Series	132
Description	132
Table of Component Parts	132
Connection Diagram	132
Ignition System—Function and Service	133
Ignition Timing	133
Ignition Coil	134
Condenser	134
Charging System	135

Battery	137
Spark Plug	139
Lighting and Signal System	140
Yamaha Genuine Parts Catalogue	154
CRANKCASE - CYLINDER	155
CRANK - PISTON	157
OIL PUMP	159
INTAKE	161
CARBURETOR	162
EXHAUST	164
CRANKCASE COVER	165
FLYWHEEL MAGNETO	166
STARTER - GENERATOR (AT2 - 3)	167
KICK - STARTER	168
CLUTCH	169
TRANSMISSION	171
TACHOMETER	173
SHIFT CAM - FORK	174
SHIFT SHAFT	176
FRAME	177
FRONT FENDER - REAR FENDER	179
REAR ARM - REAR CUSHION - CHAIN C	181
FRONT FORK	182
STEERING	184
OIL TANK	185
FUEL TANK	187
SEAT - CARRIER	189
FRONT WHEEL	190
REAR WHEEL	192
HANDLE - WIRE	194
STAND - FOOTREST - BRAKE PEDAL	196
SPEEDOMETER - TACHOMETER (AT2 -A)	197
SPEEDOMETER - TACHOMETER (CT2 -	198
HEADLIGHT (AT2 - AT3)	199
HEADLIGHT (CT2 - CT3)	200
TAILLIGHT	201
FLASHER LIGHT	203
ELECTRICAL (AT2 - AT3)	204
ELECTRICAL (CT2 - CT3)	206

YAMAHA

COMBINED

SERVICE MANUAL

LT2 LT3

AT1C

AT2 AT3

CT1C

CT2 CT3

COVERING

100cc THRU 175cc

ENDUROS

(1971 — 1973)

LIT-11613-14-01

FOREWORD

The Yamaha LT/AT/CT series machines are originally designed for off-the-road riding as a trails machine or scrambler, but they are also built to excel in medium speed performance over roads and highways. For this reason they are equipped with all the safety parts required for a street touring model.

Another attractive feature is LT and AT Series are readily converted to high-powered motocrossers with Genuine Yamaha Tuning parts.

This manual, and the technical and service information enclosed, should be closely followed to enable you to properly maintain the machines, thereby ensuring continuous good performance and long service life.

Even though this information applies to several models, many of the servicing procedures are identical. Whenever there is a difference in specifications and/or servicing procedure, the individual models will be noted. Unless otherwise noted, consider the information to be universally applicable.

YAMAHA MOTOR CO., LTD.
ENGINEERING AND SERVICE DEPARTMENT.

CONTENTS

CONTENTS

Chapter 1. General	4
Profile	4
Features	5
Specifications	6
Performance Curves	17
Tools and Instruments for Shop Service	20
Periodic Maintenance Intervals	22
Lubrication Intervals	23
Chapter 2. Yamaha Autolube	24
What is Yamaha Autolube	24
Features of Yamaha Autolube	24
Handling the Oil Pump	25
Chapter 3. Cylinder Porting	30
Description of 5 Port Cylinder	30
Construction and Features	30
The Torque Induction System	33
The Yamaha Reed Valve	34
Operation of the Torque Induction System	35
Chapter 4. Engine	40
Engine Removal	40
Cylinder Head	46
Cylinder	47
Piston Pin	49
Piston Ring	50
Piston	52
Crankcase Cover (R.H)	54
Clutch	56
Primary Drive Gear	61
Kick Starter Mechanism	62
Shift Mechanism	65
Drive Sprocket	67
Crankcase	69
Transmission Assembly	70
Crankshaft	74
Bearings and Oil Seals	77
Carburetor	78
Air Cleaner	82
Chapter 5. Chassis	83
Front Wheel	83
Rear Wheel	88
Rear Wheel Sprocket	93
Tires and Tubes	94
Front Forks	94

Rear Shocks	98
Gas Tank	99
Rear Swing Arm	101
Steering Head	103
Oil Tank, Battery Box and Tool Box	104
Frame	104
Handlebars	104
Miscellaneous	104
Chapter 6. Electrical System for LT Series	105
Description	105
Table of Component Parts	105
Connection Diagram	105
Ignition System—Function and Service	105
Ignition Timing	106
Ignition Coil	106
Condenser	107
Charging System	107
Battery	109
Checking the Main Switch (removed from the chassis)	110
Spark Plug	111
Lighting and Signal Systems	111
Chapter 7. Electrical System for AT Series	113
Description	113
Table of Component Parts	113
Main Components	114
Charging and Starting System	114
Connection Diagram	115
Starter Dynamo	116
Regulator (Voltage Regulator)	124
Ignition Coil	126
Checking the Main Switch (removed from the chassis)	127
Chapter 8. Electrical System for CT Series	128
Description	128
Table of Component Parts	128
Connection Diagram	128
Ignition System—Function and Service	129
Ignition Timing	129
Ignition Coil	130
Condenser	130
Charging System	131
Battery	133
Spark Plug	135
Lighting and Signal System	136

CHAPTER 1. GENERAL

1-1 Profile

LT2

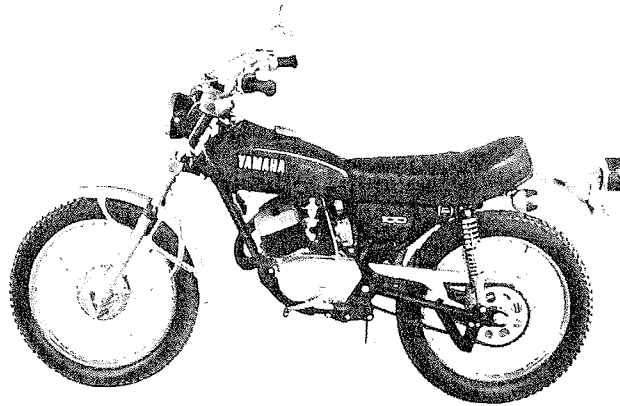

LT3

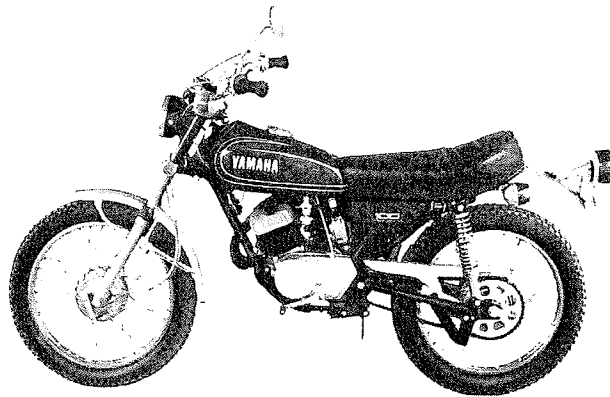

AT1-C

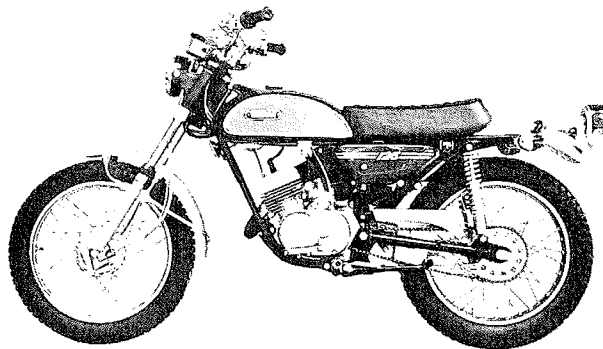

AT2

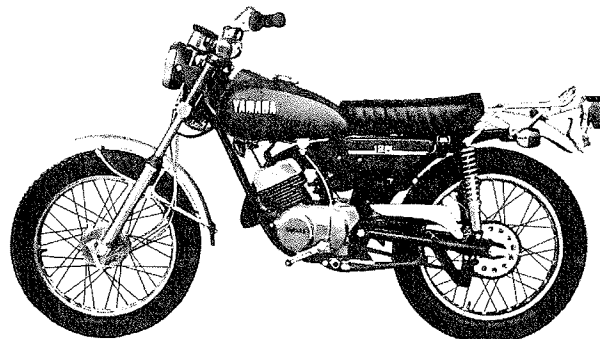

AT3

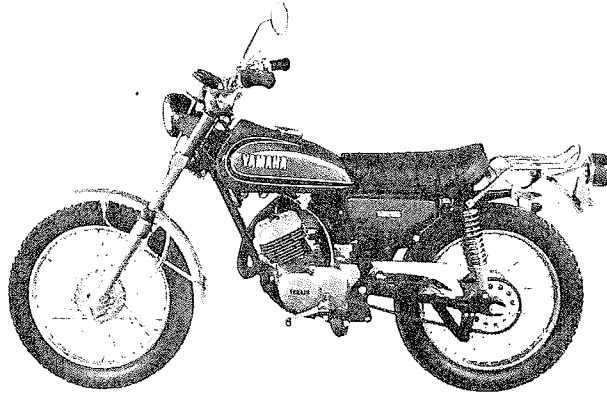

CT1-C

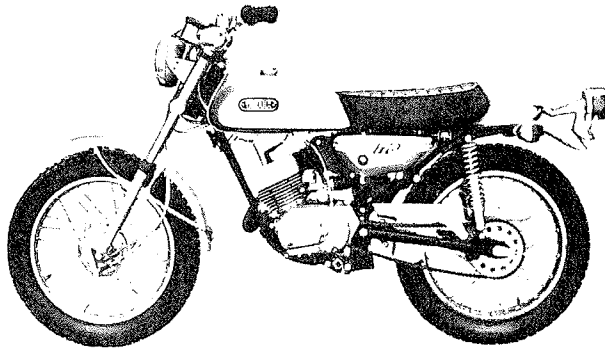

CT2

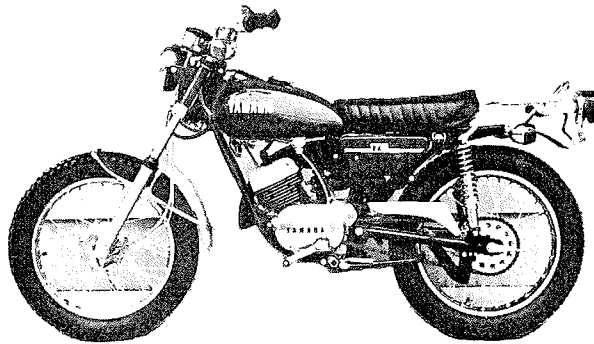

CT3

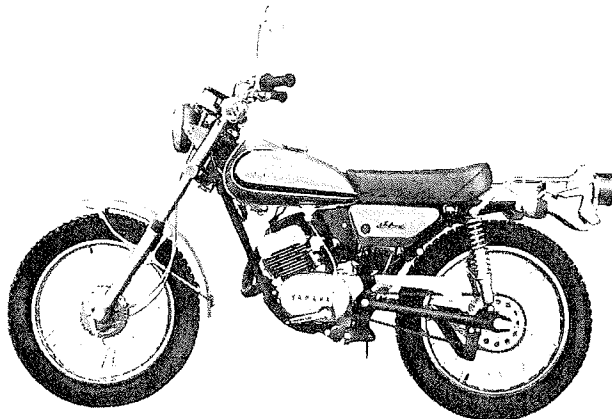

1–2 Features of Yamaha 100-175 enduros

1. 7-port Cylinder and Reed Valve Intake (1972-73 models)

The newly designed 7-port cylinder has greatly improved scavenging efficiency at all speeds. In addition, the adoption of an improved reed valve for intake ensures steady and smooth engine performance throughout the entire range of speed from low to high.

2. Highly-dependable Yamaha Autolube

Yamaha Autolube provides superior engine lubrication that extends the life of the engine.

3. Easy Starting

The engine can be started by simply disengaging the clutch and kicking the kick pedal without shifting gears back to neutral. This is a valuable convenience to the rider. The 100's and 175's are equipped with a magneto. To start the engine, kick the pedal. The AT Series have an electric starter dynamo for easier starting.

4. Powerful Brakes

Patented waterproof, dustproof brake drums provide safe, fade-free braking on wet or dusty roads.

5. Adjustable Rear Cushion

The rear cushions are adjustable for five positions. The rider can adjust spring tension to compensate for varying weight, speed, and road conditions.

6. Front Fork Design

Yamaha enduros employ a front fork design well-known for strength and superior handling characteristics. They assure the rider of the ultimate suspension for even the roughest terrain.

7. Speedometer and Tachometer

Both speedometer and tachometer are standard equipment (except 100 series). Individual units are separately mounted for maximum visibility. An additional feature of the speedometer is an odometer which can be reset to zero for trip or enduro purposes.

8. Tires

The 100-175 enduro series are fitted with tires having a universal type tread pattern as standard equipment. This particular tread is one of the most versatile available. It gives maximum trail traction and yet is compatible with road usage.

9. Carburetor Starter Feature

Yamaha's starter feature is already well-known for its easy starting. Equipped with this unique carburetor, Yamaha's are quick starting under all conditions.

GENERAL – Specifications & Performance

1–3 Specifications & Performance MODELS LT2, LT3

MODEL	LT2, LT3 (1972, 1973)
Dimensions: Overall length Overall width Overall height Wheelbase Min. ground clearance	75.2 in. (1,910 mm) 35.4 in. (900 mm) 41.3 in. (1,050 mm) 48.8 in. (1,240 mm) 8.6 in. (220 mm)
Weight: Net	187 lbs. (85 kg)
Performance: Max. speed Fuel consumption (on paved level roads) Climbing ability Min. turning radius Braking distance	58 m/h (93 km/h) 152.9 mpg at 31 mph (66 km/ℓ at 50 km/h) 27 degrees 82.7 in. (2,100 mm) 49 ft at 31 mph (15 m at 50 km/h)
Engine: Model Type Lubricating system Cylinder Displacement Bore and Stroke Compression ratio Max. power Max. torque Starting system Ignition system Ignition timing	LT2 2 stroke, gasoline Separate lubrication (YAMAHA Autolube) Single, forward inclined, torque induction 5.92 cu.in. 2.047 x 1.795 in. (52 x 45.6 mm) 6.9 : 1 10 B.H.P./7,500 r.p.m. 7.0 ft-lbs. /7,000 r.p.m.(0.97kg-m/7,000r.p.m.) Primary kick starter Magneto ignition 1.8 mm B.T.D.C.
Carburetor: Type M.J. J.N.	VM20SH #120 4J ₁₃ -2
Air cleaner:	Wet, foam rubber
Transmission: Clutch Primary reduction system Primary reduction ratio	Wet, multiple-disk Gear 3.894 (74/19)
Gear box: Type Reduction ratio 1st 2nd 3rd 4th 5th Secondary reduction system Secondary reduction ratio	Constant mesh 5-speed forward 3.182 (35/11) 2.000 (30/15) 1.368 (26/19) 1.000 (23/23) 0.800 (20/25) Chain 3.500 (49/14)

MODELS LT2, LT3

MODEL	LT2, LT3 (1972, 1973)
Chassis: Model Frame Suspension system, front Suspension system, rear Cushion system, front Cushion system, rear	LT2 Tubular double loop Telescopic fork Swinging, arm Coil spring oil damper Coil spring, oil damper
Steering system: Caster Trail	61° 4.1 in. (105 mm)
Braking system: Type of brake Operation system, front Operation system, rear	Internal expansion Right hand operation Right foot operation
Tire size: Front Rear	2.75-18-4PR 3.00-18-4PR
Flywheel magneto: Model Manufacturer	F136-07 HITACHI
Battery: Model Manufacturer Capacity	6N4A-4D FURUKAWA Battery 6V, 4AH
Lighting: Head light Tail light Stop light Meter light Flasher light High beam indicator light	6V, 25W/25W 6V, 5.3W 6V, 17W 6V, 3W 6V, 17W 6V, 1.5W
Tanks: Gasoline tank capacity Oil tank capacity	1.6 US gals. (6 ℓ) 1.3 US qts. (1.2 ℓ)

GENERAL – Specifications & Performance

MODELS AT1-C

MODEL	AT1-C
Dimensions: Overall length Overall width Overall height Wheelbase Min. ground clearance	77.2 in. (1,960 mm) 35.8 in. (910 mm) 42.9 in. (1,090 mm) 50.6 in. (1,285 mm) 8.9 in. (225 mm)
Weight: Net	221 lbs. (100 kg)
Performance: Max. speed Fuel consumption (on paved level roads) Climbing ability Min. turning radius Braking distance	65 mph plus (100 km/h plus) 141.1 mpg at 25 mph (60 km/ℓ at 40 km/h) 30 degrees 74.8 in. (1,900 mm) 59.3 ft at 31 mph (14.8 m at 50 km/h)
Engine: Model Type Lubricating system Cylinder Displacement Bore x Stroke Compression ratio Max. power Max. torque Starting system Ignition system Ignition timing	AT1 2 stroke, gasoline Separate lubrication (YAMAHA Autolube) Single, forward inclined, 5 port 7.51 cu.in. (123 c.c.) 2.205 in. x 1.969 in. (56 mm x 50 mm) 7.1 : 1 11.5 B.H.P./7,500 r.p.m. 8.5 ft-lb/6,000 r.p.m. (1.17 kg-m/6,000 r.p.m.) Electric & kick starter Battery ignition 1.8 mm. B.T.D.C.
Carburetor: Type M.J. J.N.	VM24SH #150 4D3-3 Stages
Air cleaner:	Wet, foam rubber
Transmission: Clutch Primary reduction system Primary reduction ratio	Wet, multiple-disk Gear 3.894 (74/19)
Gear box: Type Reduction ratio 1st 2nd 3rd 4th 5th Secondary reduction system Secondary reduction ratio	Constant mesh, 5-speed forward 3.181 (35/11) 39.81 2.000 (30/15) 25.03 1.368 (26/19) 17.12 1.000 (23/23) 12.52 0.800 (20/25) 10.01 Chain 3.214 (45/14)

GENERAL – Specifications & Performance

MODEL AT1-C

MODEL	AT1-C
Chassis: Model Frame Suspension system, front Suspension system, rear Cushion system, front Cushion system, rear	AT1 Tubular-Double loop Telescopic fork Swinging arm Coil spring, oil damper Coil spring, oil damper
Steering system: Steering angle Caster Trail	49 ° both right and left 60 ° 30' 4.72 in. (120 mm)
Braking system: Type of brake Operation system, front Operation system, rear	Internal expansion Right hand operation Right foot operation
Tire size: Front Rear	3.00-18-4PR 3.25-18-4PR
Dynamo: Model Manufacturer	GS114 HITACHI
Battery: Model Manufacturer Capacity	12N7-3B FURUKAWA Battery 12V, 7AH
Lighting: Head light Tail light Stop light Meter light Flasher light High beam indicator light	12V, 25WD 12V, 7W 12V, 27W 12V, 3Wx2 12V, 27W 12V, 2W
Tanks Gasoline tank capacity: Oil tank capacity	1.9 US gals. (7.2 ℓ) 1.3 US qts. (1.2 ℓ)

MODELS AT2, AT3

MODEL	AT2, AT3 (1972, 1973)
Dimensions: Overall length Overall width Overall height Wheelbase Min. ground clearance	77.2 in. (1,960 mm) 35.8 in. (910 mm) 42.9 in. (1,090 mm) 50.6 in. (1,285 mm) 8.9 in. (225 mm)
Weight: Net	221 lbs. (100 kg)
Performance: Max. speed Fuel consumption (on paved level roads) Climbing ability Min. turning radius Braking distance	65 mph plus (105 km/ℓ plus) 129.4 mpg at 31 mph (55 km/ℓ at 50 km/h) 30 degrees 74.8 in. (1,900 mm) 49 ft at 31 mph (15 m at 50 km/h)
Engine: Model Type Lubricating system Cylinder Displacement Bore x Stroke Compression ratio Max. power Max. torque Starting system Ignition system	AT1 2 stroke Air cools gasoline Separate lubrication (YAMAHA Autolube) Torque induction 7.51 cu.in. (123 c.c.) 2.205 in. x 1.969 in. (56 x 50 mm) 7.1 : 1 13 BHP/7,000 r.p.m. 10 ft-lb/6,000 r.p.m. (1.38 kg-m/6,000 r.p.m.) Electric & kick starter Battery ignition
Carburetor: Type M.J J.N	VM24SH # 230 5J3-3rd Stage
Air cleaner:	Wet, foam rubber
Spark plug:	NGK B-8ES
Transmission: Clutch Primary reduction, system Primary reduction ratio	Wet, multiple-disk Gear 3.894 (74/19)
Gear box: Type Reduction ratio 1st 2nd 3rd 4th 5th Secondary reduction system Secondary reduction ratio	Constant mesh, 5-speed 3.181 (35/11) 2.000 (30/15) 1.368 (26/19) 1.000 (23/23) 0.800 (20/25) Chain 3.000 (45/15)

GENERAL – Specifications & Performance

MODELS AT2, AT3

MODEL	AT2, AT3 (1972, 1973)
Chassis: Model Frame: Suspension system, front Suspension system, rear Cushion system, front Cushion system, rear	AT1 Tubular-Double loop Telescopic Swinging arm Coil spring, oil damper Coil spring, oil damper
Steering system: Steering angle Caster Trail	49° both right and left 60° 31' 4.7 in.
Braking system: Type of brake Operation system, front Operation system, rear	Internal expansion Right hand operation Right foot operation
Tire size: Front Rear	3.00-18-4PR (Trials Universal) 3.25-18-4PR (Trials Universal)
Dynamo: Model Manufacturer	GS114-01 HITACHI
Battery: Model Capacity	12N7-3B or 12N7-3B-1 12V 7AH
Lighting: Head light Tail light Stop light Meter light Flasher light High beam indicator light	12V 25W/25W 12V 7W 12V 27W 12V 3W x 2 12V 27W 12V 2W
Tanks: Gasoline tank capacity Oil tank capacity	1.8 US gals. (7.0 ℓ) 1.3 US qts. (1.2 ℓ)

MODEL CT1-C

MODEL	CT1-C
Dimensions: Overall length Overall width Overall height Wheelbase Min. ground clearance	78.0 in. (1,980 mm) 35.8 in. (910 mm) 43.7 in. (1,110 mm) 50.8 in. (1,290 mm) 9.4 in. (240 mm)
Weight: Net	214 lbs. (97 kg)
Performance: Max. speed Fuel consumption (on paved level roads) Climbing ability Min. turning radius Braking distance	65 mph plus (105 km/h plus) 117.6 mpg at 31 mph (50 km/ℓ at 50 km/h) 32 degrees 74.8 in. (1,900 mm) 49 ft at 31 mph (15 m at 50 km/h)
Engine: Model Type Lubricating system Cylinder Displacement Bore x Stroke Compression ratio Max. power Max. torque Starting system Ignition system Ignition timing	CT1 2 stroke, gasoline Separate lubrication (YAMAHA Autolube) Single, forward inclined, 5-port 10.43 cu.in. (171 c.c.) 2.598 in. x 1.969 in. (66 x 50 mm) 6.8 : 1 15.6 BHP/7,000 r.p.m. 11.9 ft-lb/5,500 r.p.m. (1.65 kg-m/5,500 r.p.m.) Kick starter Magneto ignition 1.8 mm. B.T.D.C.
Carburetor: Type M.J. J.N.	VM24SH # 150 4D3-3 Stages
Air Clearaner:	Wet, foam rubber
Transmission: Clutch Primary reduction system Primary reduction ratio	Wet, multiple-disk Gear 3.894 (74/19)
Gear box: Type Reduction ratio 1st 2nd 3rd 4th 5th Secondary reduction system Secondary reduction ratio	Constant mesh, 5-speed forward 3.181 (35/11) 34.86 2.000 (30/15) 21.91 1.368 (26/19) 14.98 1.000 (23/23) 10.95 0.800 (20/25) 8.76 Chain 2.812 (45/16)

GENERAL – Specifications & Performance

MODEL CT1-C

CT1-C	CT1-C
Chassis: Model Frame Suspension system, front Suspension system, rear Cushion system, front Cushion system, rear	CT1 Tubular-Double loop Telescopic fork Swinging arm Coil spring, oil damper Coil spring, oil damper
Steering system: Steering angle Caster Trail	49° both right and left 60° 30' 4.8 in. (123 mm)
Braking system: Type of brake Operation system, front Operation system, rear	Internal expansion Right hand operation Right foot operation
Tire size: Front Rear	3.25-18-4PR 3.50-18-4PR
Dynamo: Model Manufacturer	F130-06 HITACHI
Battery: Model Manufacturer Capacity	MV1-6D FURUKAWA Battery 6V, 2AH
Lighting: Head light Tail light Stop light Meter light Flasher light High beam indicator light	6V, 25W/25W 6V, 5.3W 6V, 17W 6V, 3W x 2 6V, 17W 6V, 1.5W
Tanks: Gasoline tank capacity: Oil tank capacity	1.9 US gals. (7.2 l) 1.3 US qts. (1.2 l)

GENERAL – Specifications & Performance

MODEL CT2, CT3

MODEL	CT2, CT3 (1972, 1973)
Dimensions: Overall length Overall width Overall height Wheelbase Min. ground clearance	77.2 in. (1,980 mm) 35.8 in. (910 mm) 42.9 in. (1,110 mm) 50.6 in. (1,290 mm) 8.9 in. (240 mm)
Weight: Net	214 lbs. (97 kg)
Performance: Max. speed Fuel consumption (on paved level roads) Climbing ability Min. turning radius Braking distance	67 mph plus (107 km/h plus) 117.6 mpg at 31 mph (50 km/ℓ at 50 km/h) 30 degrees 74.8 in. (1,900 mm) 49 ft at 31 mph (15 m at 50 km/h)
Engine: Model Type Lubricating system Cylinder Displacement Bore x Stroke Compression ratio Max. power Max. torque Starting system Ignition system	CT1 2 stroke Air cools gasoline Separate lubrication (YAMAHA Autolube) Torque induction 10.43 cu.in. (171 cc) 2.508 x 1.969 in. (66 x 50 mm) 7.1 : 1 16 BHP/6,500 r.p.m. 11.9 ft-lb/6,000 r.p.m. (1.65 kg-m/6,000 r.p.m.) Kick starter Magneto ignition
Carburetor: Type M.J J.N	VM24SH #230 4J13-2nd Stage
Air cleaner:	Wet, foam rubber
Spark plug:	NGK B-8ES
Transmission: Clutch primary reduction system Primary reduction ratio	Wet, multiple-disk Gear 3.894 (74/19)
Gear box: Type Reduction ratio 1st 2nd 3rd 4th 5th Secondary reduction system Secondary reduction ratio	Constant mesh, 5-speed 3.181 (35/11) 2.000 (30/15) 1.368 (26/19) 1.000 (23/23) 0.800 (20/25) Chain 2.812 (45/16)

MODEL CT2, CT3

MODEL	CT2, CT3 (1972, 1973)
Chassis: Model Frame Suspension system, front Suspension system, rear Cushion system, front Cushion system, rear	CT1 Tubular-Double loop Telescopic Swinging arm Coil spring, oil damper Coil spring, oil damper
Steering system: Steering angle Caster Trail	49° both right and left 60° 31' 4.8 in.
Braking system: Type of brake Operation system, front Operation system, rear	Internal expansion Right hand operation Right foot operation
Tire size: Front Rear	3.25-18-4PR (Trials Universal) 3.50-18-4PR (Trials Universal)
Dynamo: Model Manufacturer	F130-06 HITACHI
Battery: Model Capacity	6N4A-40 6V, 4AH
Lighting: Head light Tail light Stop light Meter light Flasher light High beam indicator light	6V, 25W/25W 6V, 5.3 6V, 17W 6V, 3W x 2 6V, 17W 6V, 1.5W
Tanks: Gasoline tank capacity Oil tank capacity	1.8 US gals (7.0 l) 1.3 US qts. (1.2 l)

1-4 Performance curves

100 LT2 & LT3 ENGINE PERFORMANCE CURVES

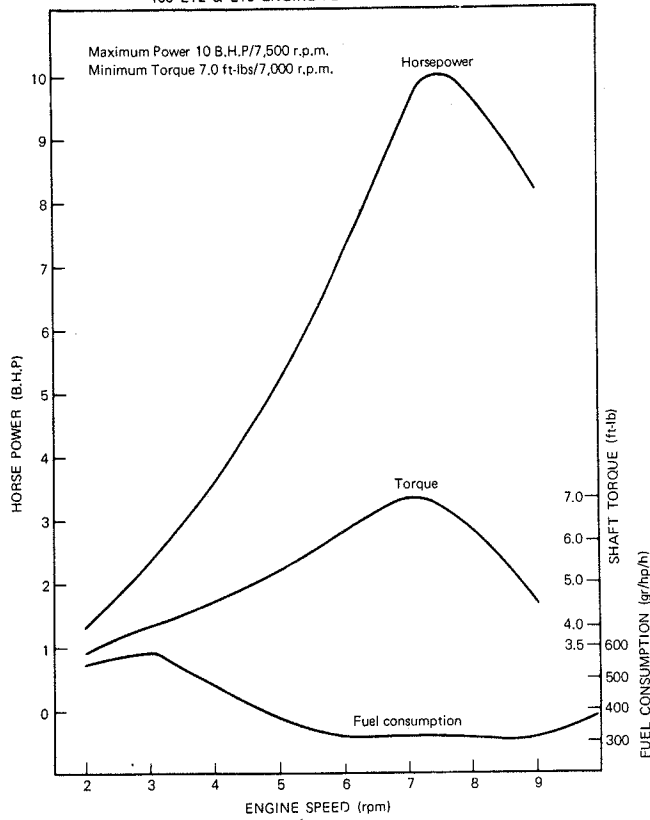

100 LT2 & LT3 DRIVING PERFORMANCE CURVES

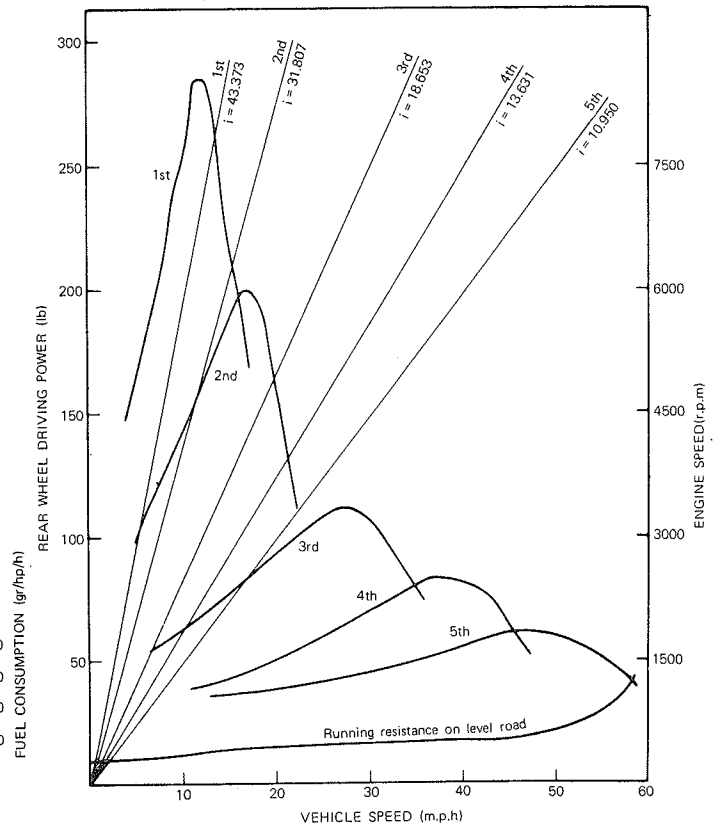

AT1-C ENGINE PERFORMANCE CURVES

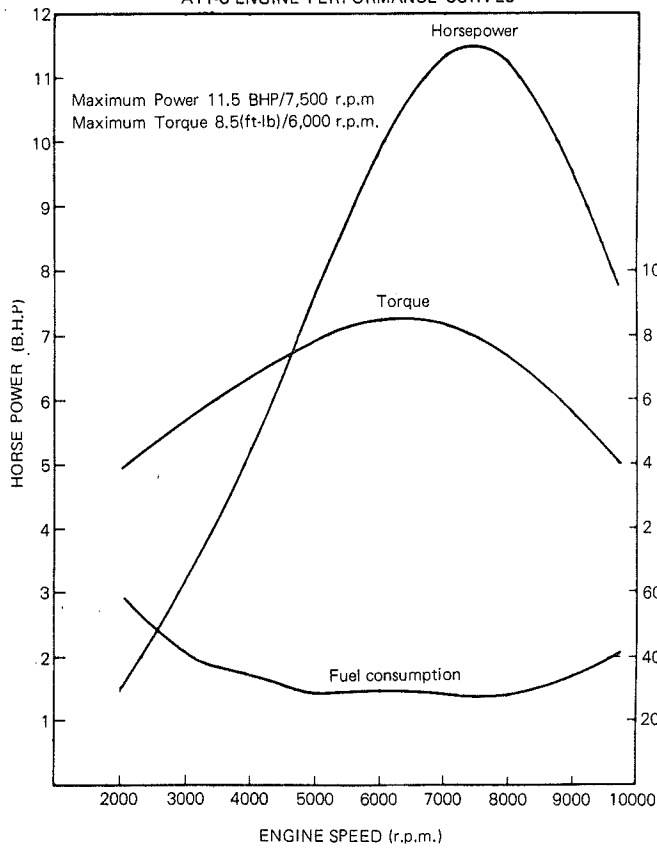

AT1-C DRIVING PERFORMANCE CURVES

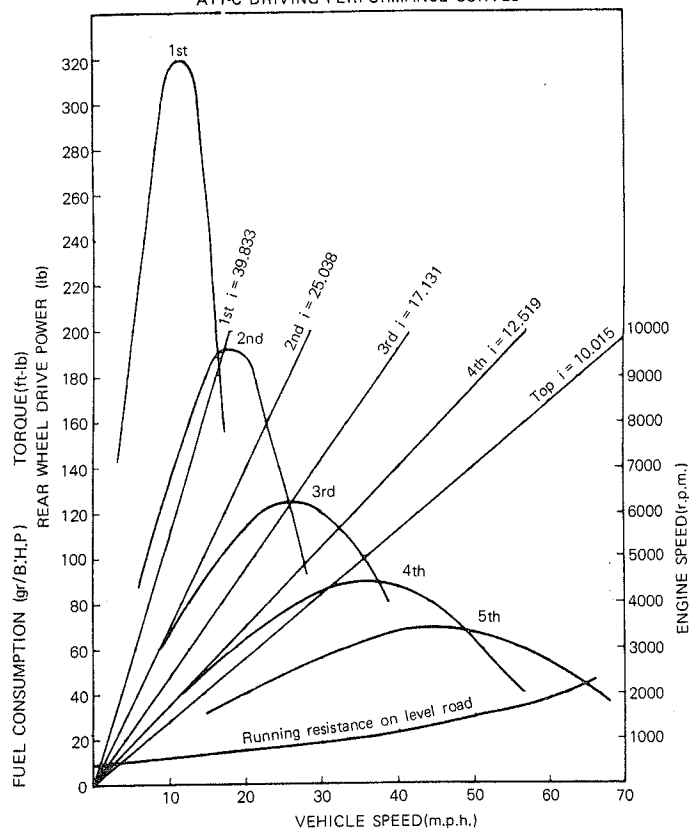

GENERAL – Performance Curves

125 AT2 & AT3 ENGINE PERFORMANCE CURVES

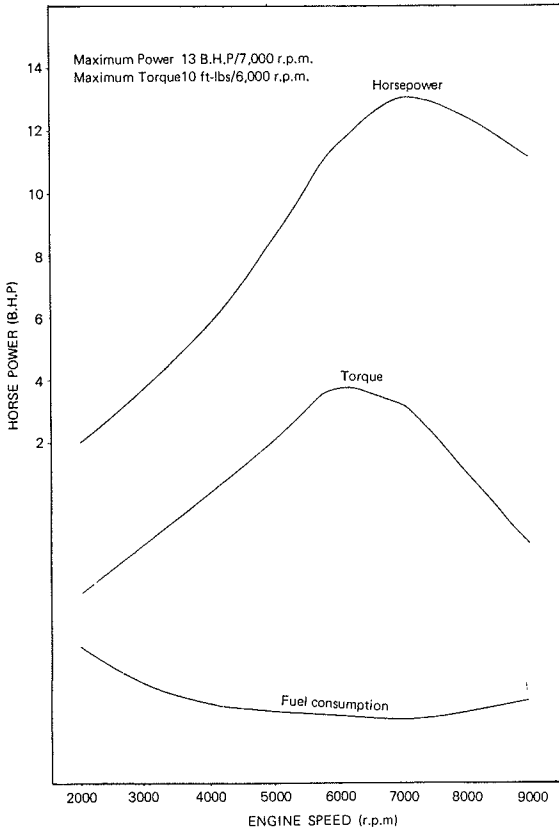

125 AT2 & AT3 DRIVING PERFORMANCE CURVES

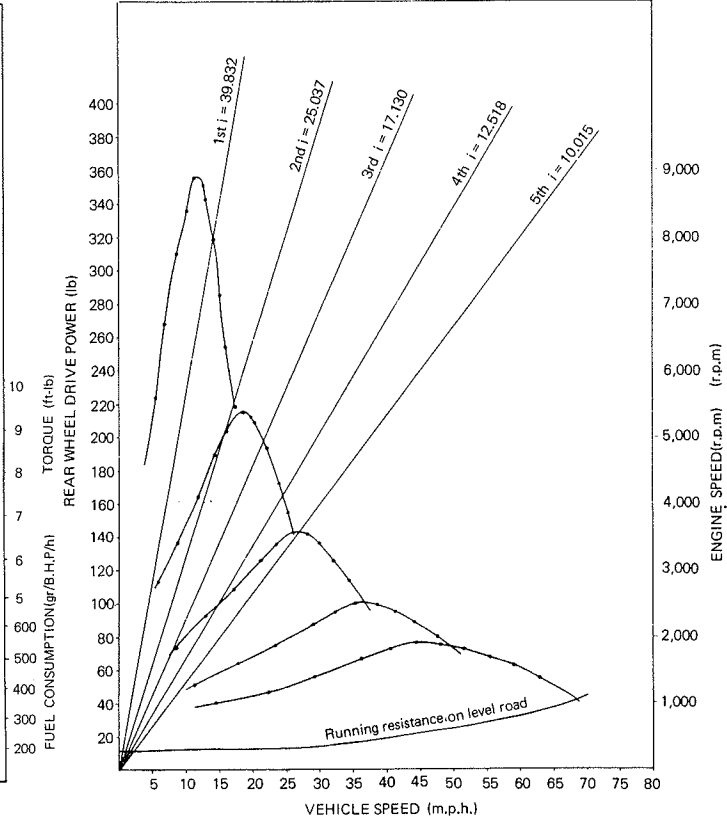

CT1-C ENGINE PERFORMANCE CURVES

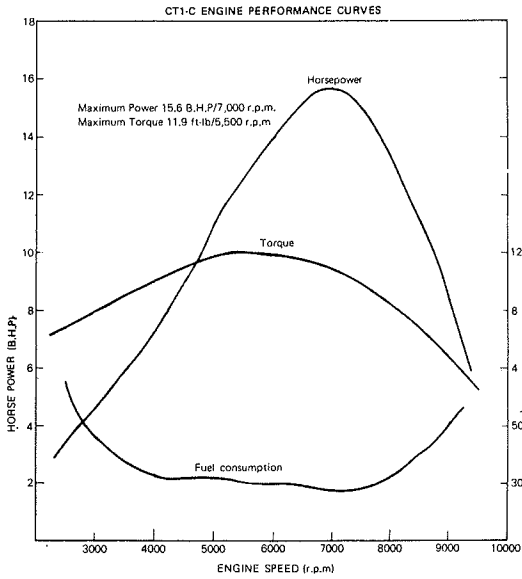

CT1-C DRIVING PERFORMANCE CURVES

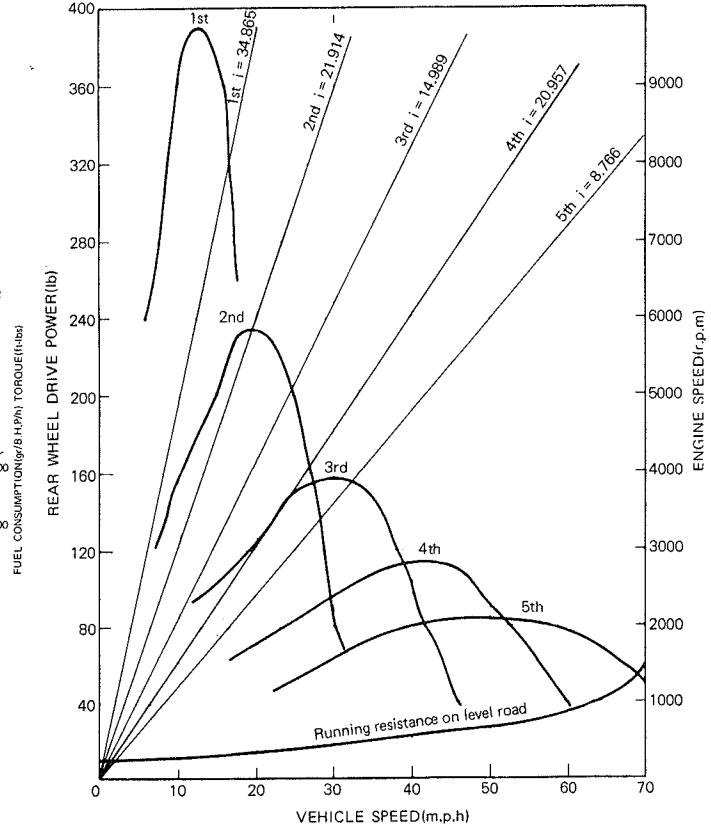

GENERAL – Performance Curves

175 CT2 & CT3 ENGINE PERFORMANCE CURVES

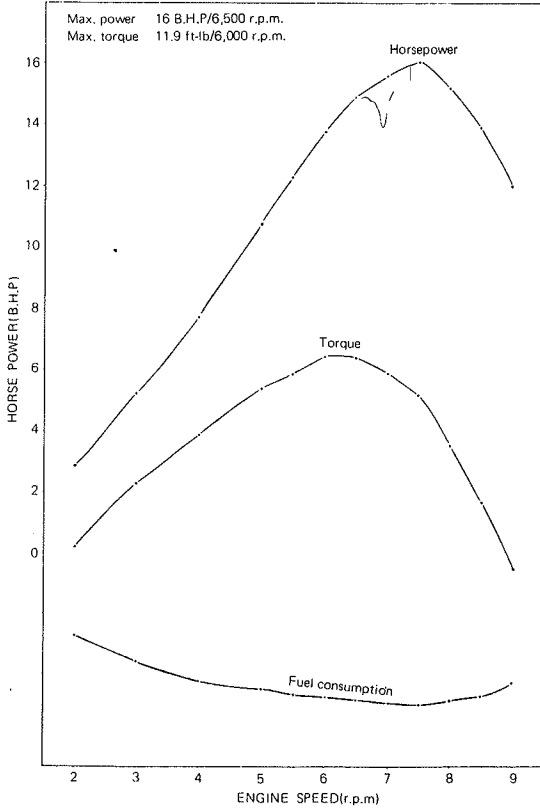

175 CT2 & CT3 DRIVING PERFORMANCE CURVES

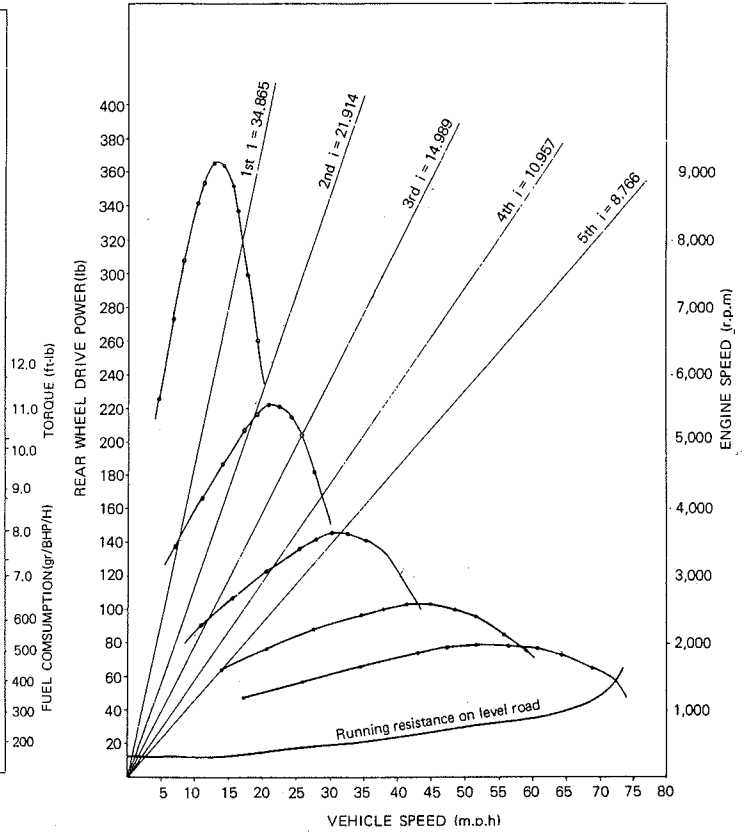

1–5 Tools and Instruments for Stop Service

The following tools and instruments are required to service the LT/AT/CT series.

1. General Tools

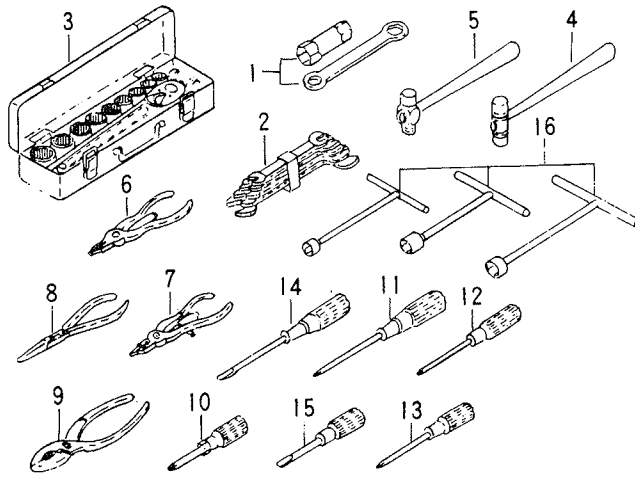

- | | | |
|-----------------------------|-----------------------------------|-----------------------------------|
| 1) Plug wrench 23 x 29 mm. | 7) Circlip pliers (TR type) | 13) Phillips-head screwdriver (S) |
| 2) A set of wrenches | 8) Needle nose pliers | 14) Slot-head screwdriver (M) |
| 3) A set of socket wrenches | 9) Pliers | 15) Slot-head screwdriver (S) |
| 4) Plastic tip hammer | 10) Phillips-head screwdriver | 16) T-handle socket wrench |
| 5) Steel hammer | 11) Phillips-head screwdriver (L) | |
| 6) Circlip pliers (ST type) | 12) Phillips-head screwdriver (M) | |

2. Special Tools and instruments

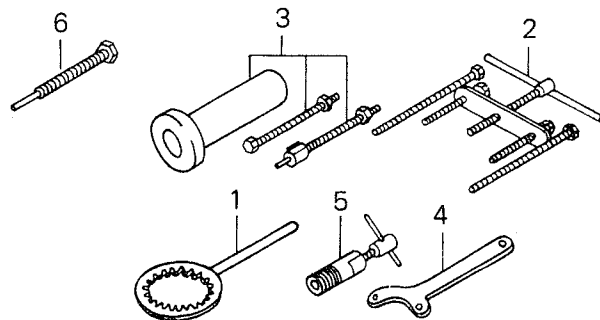

- | | |
|--|------------------------------------|
| 1) Clutch holding tool | 5) Flywheel magneto puller (LT,CT) |
| 2) Crankcase disassembling tool | 6) Armature puller (AT) |
| 3) Crankshaft assembling tool | |
| 4) Flywheel magneto holding tool (LT,CT) | |

In addition, an electro-tester, tachometer (engine rpm meter) hydrometer, etc. should be on hand.

3. Other Materials

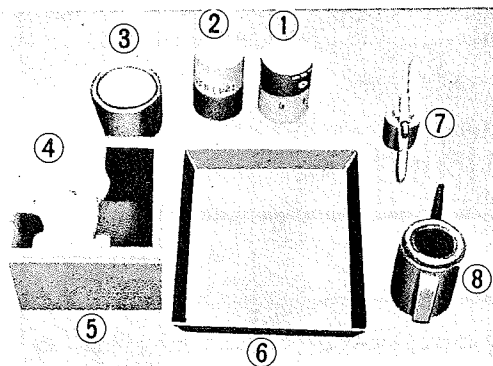

- | | |
|----------------------------|-----------------------------------|
| 1) Grease | 5) Overhauling stand (Wooden box) |
| 2) Autolube oil | 6) Parts tray |
| 3) Yamaha Bond (No. 4 & 5) | 7) Oiler |
| 4) Wiping material | 8) Oil jug |

The use of a wooden box as shown in the above photo will facilitate engine service and overhaul. Consumable parts (such as gaskets) and replacement parts must also be on hand.

1-6 Periodic Maintenance Intervals

Page	Item	Remarks	Initial			Thereafter every			
			250	500	1,000	2,000	1,000	2,000	8,000
86	Brake System (Complete)	Chk/Adj as req'd - Repair as req'd		0	0				0
56	Clutch	Check/Adjust as required		0	0				0
134	Battery	Top-Off/Ck spec, gr, as req'd - monthly - or →	0	0	0				0
111	Spark Plug(s)	Inspect/Clean or replace as req'd	0	0	0				0
136	Wheels & Tires	Pressure/Spoke Tension/Runout	0	0	0				0
86	Fittings & Fasteners	Tighten before each trip and/or →	0	0	0				0
91	Autolube	Cable operation/Adjustment ①	0	0	0				0
24	Drive Chain	Tension/Alignment ④	0	0	0				0
—	Engine Oil Level		0	0	0				CHK 0
82	Air Filter	Foam Type - See Service Note ②, ④	0	0	0				0
—	Fuel Petcock	Clean/Flush tank as Req'd	0		0				0
106	Ignition Timing	Adjust/Clean or repl. pts. as Req'd		0	0				0
122	Carburetor Adjustment	Check Operation/Synch./Fittings		0	0				0
130	Carburetor Overhaul	Clean/Repair as Req'd/Refit/Adjust				0			0
81	Cylinder Compression	Preventive Maintenance check		0	0				0
80	Decarbonize Engine	Includes Exhaust System			0				0

③ ALSO PREOPER CHECK

SERVICE NOTES:

1. Check autolube tank level before each ride or every 100 miles. Top off when oil level shows at the sight glass or before any long trip. See "Lubrication Intervals" for type oil to use.
2. Foam element air filters must be damp with oil at all times to function properly. Remove, clean, and oil filter at least once per month or every 500-1,000 miles; more often if possible. (If extremely hard, usage, such as dirt riding, clean and lube daily). See lubrication chart for add'l details.
3. Pre-operational checks should be made each time the machine is used. Such an inspection can be thoroughly accomplished in a very short time, and the added safety it assures the rider is more than worth the minimal time involved.
4. For add'l: into-drive chain, engine oil level, wet-type air filter; See lube chart.

1-7 Lubrication Intervals

Page	Item	Remarks	Type	Period										
				Initial			Thereafter							
				250	500	1,000	2,000	1,000	2,000	4,000	8,000			
24	Autolube	See Service Notes	# 1											
40	Trans. oil	Warm engine before draining	# 2				0	CHK	0					
—	Drive Chain	Lube/Adjust as req'd	# 3											
—	Drive Chain	Remove/Clean/Lube/Adjust	# 3				0		0					
82	Air Filter	Foam type	# 9											
—	Control & Meter Cables	All-Apply Thoroughly	# 4			0								
—	Throttle Grip & Housing	Light Application	# 5			0								
—	Tacho & Speedo Gear Hsgs.	Light Application	# 5				0						0	
102	Rear Arm Pivot Shaft	Zirc-Apply until shows	# 6				0						0	
—	Brake Pedal Shaft	Light Application	# 5				0						0	
66	Change Pedal Shaft	Light Application	# 5				0						0	
—	Stand Shaft Pivot	Light Application	# 5				0						0	
98	Front Forks	Drain Completely-Ck Specs	# 3			CHK			0			CHK	0	
103	Steering Ball Races	Inspect Thoroughly/Med. pack	# 7						0				0	
—	Point Cam Lubr. Wick	Very Light Application	# 8				0						0	
87	Wheel Bearings	Do not Over-Pack	# 7						0				0	

1 Check tank level before each rider or every 100 miles. Top off when oil level is at sight glass or before any long trip. Use the following lubricant (in order of preference):

Yamalube, or; two-stroke oil labeled "BIA certified for service TC-W"

2 At ambient temperatures of 45-90 ° F. use 10W/30 "SE".

3 Use 10W-30 "SE" motor oil. (If desired, specialty type lubricants of quality manufacture may be used.)

"Drive Chains" - Lube every 200-250 miles. If severe usage daily.

4 Use graphite base type (specialty types available - use name-brand, quality manufacturer).

5 Light duty; Smooth, light-weight, "white" grease. Heavy duty: Standard 90 wt. lube grease (do not use lube grease on throttle/housing).

6 Use standard 90 wt. lube grease - smooth, not coarse.

7 Medium-weight wheel bearing grease of quality mfr. - preferably waterproof.

8 Light-weight machine oil.

9 Air filters- Foam element air filters must be damp with oil at all times to function properly. Clean and lube monthly or per mileage. If hard usage, clean and lube daily. Do not over-oil. Use SAE 10W/30 "SE".

CHAPTER 2. YAMAHA AUTOLUBE (Automatic, Separate Lubricating System)

2-1 What is YAMAHA Autolube?

Conventional 2-stroke engines are lubricated by oil premixed in gasoline, but YAMAHA's Autolube furnishes an automatic, separate lubrication system. That is, the oil in a separate oil tank is automatically regulated by the oil pump and fed to the engine according to engine speed and load.

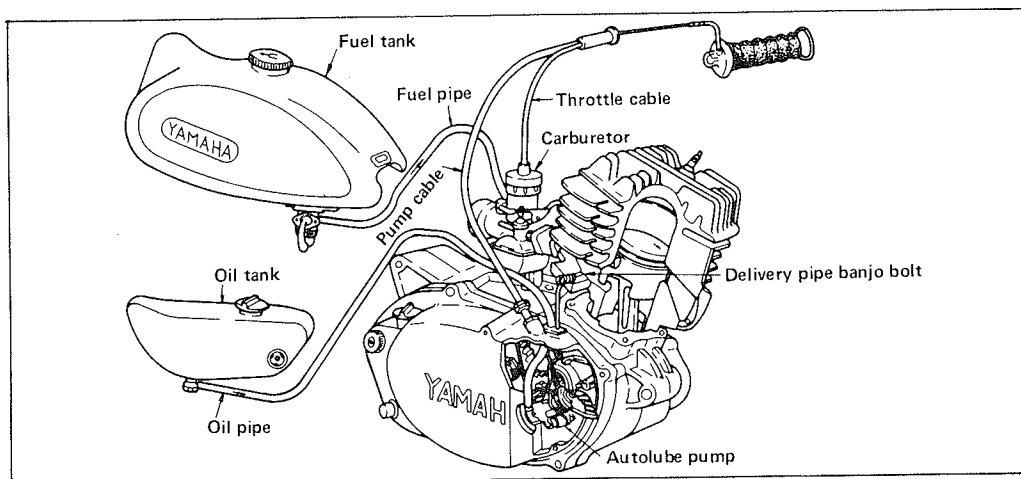

2-2 Features of YAMAHA Autolube

The oil pump is driven by the engine through a reduction gear, and is connected to the carburetor throttle cable, which in turn is controlled by the accelerator grip. The oil pump automatically regulates the volume of lubricating oil according to engine speed and throttle valve opening, thus pumping the precise amount of oil for engine lubrication under any operating condition.

This "automatic, separate lubrication" does not merely eliminate disadvantages in the conventional pre-mix system, but it further improves the performance and efficiency of 2-stroke designs by eliminating certain oil-starvation conditions which formerly existed.

- A) The Autolube feeds an optimum amount of lubricating oil to the engine under any operating condition, thus featuring.
- Less oil consumption.
 - Less carbon accumulation.
 - Less exhaust smoke.
 - Improved lubricating efficiency.
- B) The Autolube simplifies fuel supply, thus featuring:
- Using straight gasoline directly in the gas tank.
 - Less fuel contamination.
- C) The Autolube improves the reliability of lubrication, thus eliminating:
- Special care concerning oil/fuel mixing ratio.

This "automatic, separate lubrication" does not merely eliminate disadvantages in the conventional pre-mix system, but it further improves the performance and efficiency of 2-stroke designs by eliminating certain oil-starvation conditions which formerly existed.

A) The Autolube feeds an optimum amount of lubricating oil to the engine under any operating condition, thus featuring:

- Less oil consumption.
- Less carbon accumulation.
- Less exhaust smoke.
- Improved lubricating efficiency.

B) The Autolube simplifies fuel supply, thus featuring:

- Using straight gasoline directly in the gas tank.
- Less fuel contamination.

C) The Autolube improves the reliability of lubrication, thus eliminating:

- Special care concerning oil/fuel mixing ratio.

2-3 Handling the Oil Pump

The oil pump is a precision-machined assembly. Make no attempt to disassemble it. When you remove the oil pump from the engine, protect it from dust, dirt, etc., and after reinstalling it, bleed and adjust the pump correctly. Proper handling will keep the pump free from trouble.

The oil pump is similar in both construction and operation to other Autolube systems. The only difference is the employment of a 5.5 diameter plunger because of larger consumption of oil by a 100–175 c.c. single cylinder engine.

2-3-A. Checking Minimum Pump Stroke

1) Checking

- a. Fully close the accelerator grip.
- b. Turn the oil pump starter plate in the direction of the arrow marked on the plate. Then measure the gap between the adjusting pulley and the adjusting plate. Keep the gap as wide as possible by observing it with the eye.



YAMAHA AUTOLUBE – Handling the Oil Pump

c. Insert a feeler gauge (0.15 mm.) into the gap.

When the gap allows it to enter

..... Stroke is correct.

When the gap does not allow

..... Stroke is insufficient.

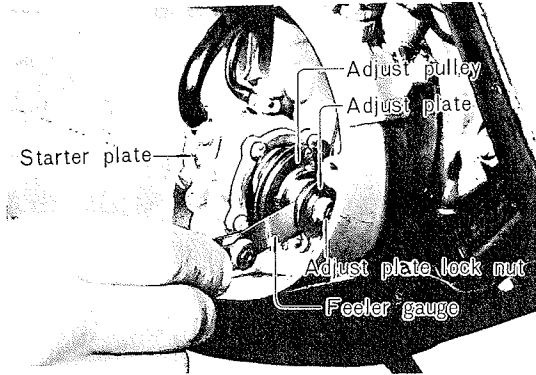

2) Adjustment

a. Remove the adjusting plate lock nut, and then remove the adjusting plate.

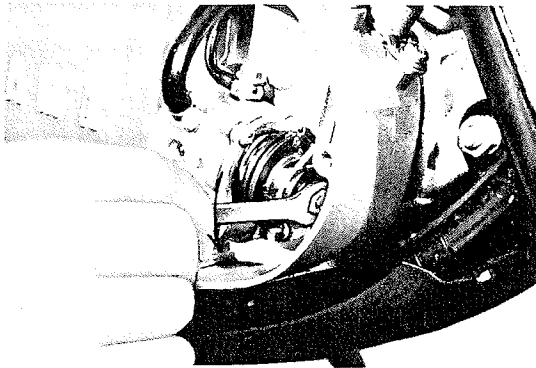

b. Install a 0.1 mm. adjusting shim where the adjusting plate was.

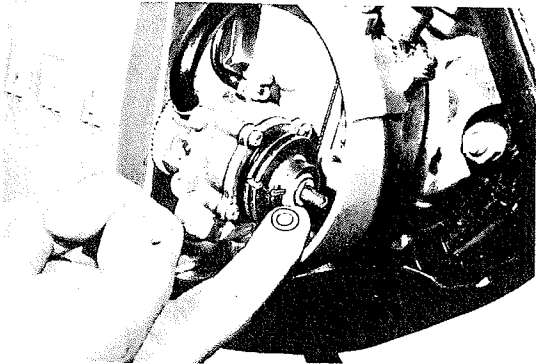

c. Reinstall the adjusting plate lock nut, and measure minimum stroke. When the gap allows a 0.20 mm. feeler gauge to enter but does not allow a 0.25 mm, the stroke is correctly adjusted.

Stroke nominal clearance 0.20 to 0.25 mm.

Minimum allowable clearance 0.15mm.

2-3-B. Carburetor and Autolube Cable Adjustments

Follow the preceding in section 2-3-A steps to check minimum stroke, and adjust it if incorrect. Then adjust the carburetor and pump as described in the steps below.

1) Throttle Cable Adjustment

- a. Adjust the carburetor with the engine at idle, and remove all but 1 mm of slack from throttle cable B.

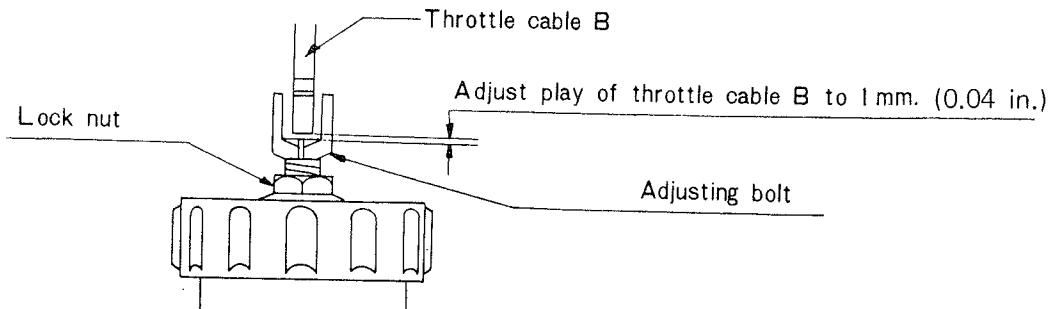

To bring the play of the throttle cable into correct adjustment, loosen or tighten the throttle cable adjustment screw.

To check this adjustment, lightly pull throttle cable B, and engine speed should slightly increase from idling r.p.m.

- b. Next, adjust throttle cable (A) so that the gap as shown below will be between 0.5 and 1.0 mm. (0.02~0.04 in.)

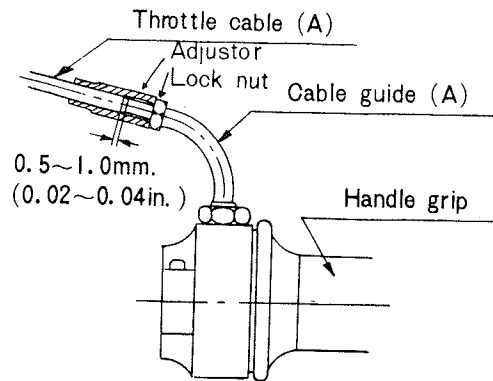

Check the play of the throttle cable(A) by pulling the outer part of the cable. If the play is excessive or insufficient, adjust the play with the adjustment screw.

2) Autolube Cable Adjustment

- a. Adjust the pump cable so that the marking (arrow) on the Autolube pump adjustment pulley is aligned with the guide pin (see Fig. 2-3-8). Begin by fully closing the accelerator grip, then slowly turning it back again so that the slack in the throttle cable is completely taken up. Next, adjust the pump cable so that the marking on the pump adjustment pulley will be aligned with the guide pin, as shown in Fig. 2-3-7. The point of adjustment is at the end of the cable, just before it enters the case. Loosen the lock nut and screw the adjuster in or out, whichever direction is necessary to obtain the correct adjustment.

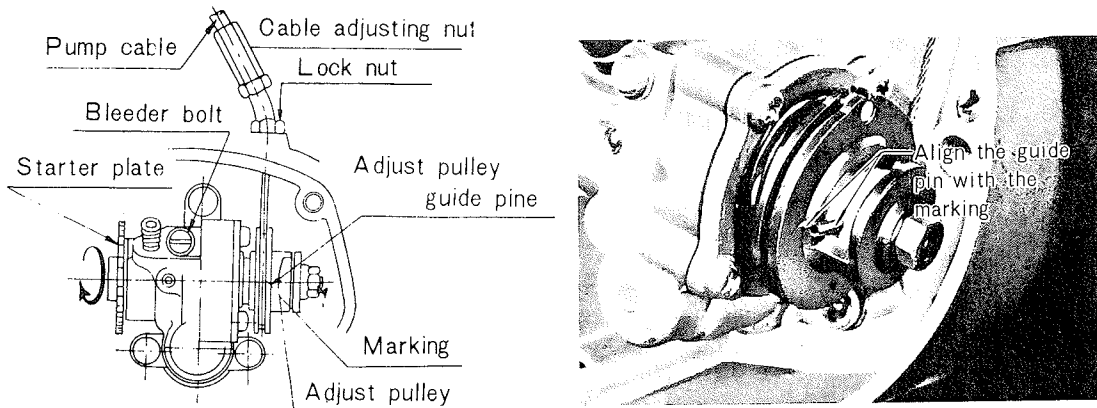

2-3-C. Bleeding

When the pump has been removed or the Autolube oil has run out, air will enter the pump. The air will cause an irregular flow of oil after the pump is mounted again or the oil tank is refilled. In order to prevent such an irregular flow of oil, bleed the pump in the following manner.

- 1) Remove the bleeder bolt.

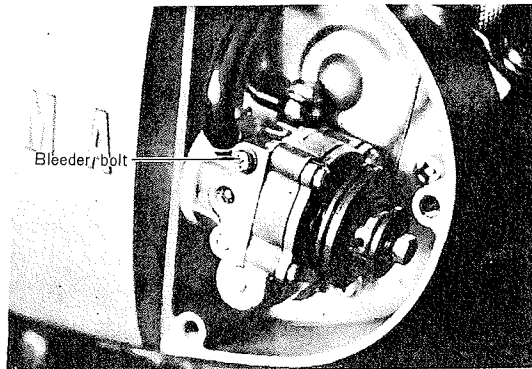

2. Next, rotate the starter plate in the direction of the arrow marked on the plate. Continue turning the plate until no air comes out with the oil, then tighten the bleeder bolt. To facilitate this bleeding, fully open the accelerator grip and rotate the starter plate. As the plunger stroke becomes greater, the air can be quickly bled.

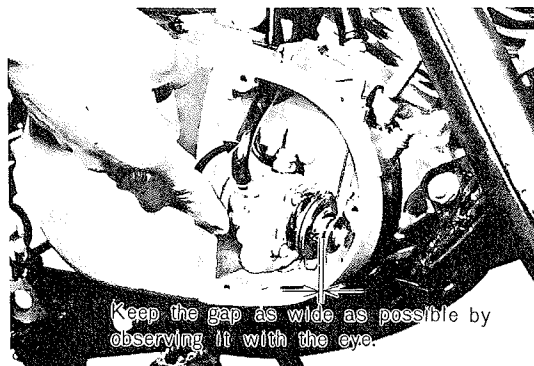

CHAPTER 3. CYLINDER PORTING

3–1 Description of 5-Port Cylinder (AT1C, CT1C)

The Schnuerle loop scavenging system is the most commonly used induction system for two-stroke engines. In the Schnuerle loop system, transfer ports on the right and left sides of the cylinder are employed to transfer 2 streams of fresh fuel in the loop design that had proved to be the most effective induction system until the innovation of Yamaha's 5-port cylinder. This conventional Schnuerle loop system had a design limit in that the transfer ports could not be made large enough to completely clear the combustion chamber of exhaust gases because of the position of the intake and exhaust ports. This would result in a portion of exhaust gas remaining in the central area of the combustion chamber that would contaminate the fresh fuel charge.

The rotary valve induction system incorporates the use of a 3rd transfer port at the back of the cylinder that directs a fresh fuel charge to the dead area containing the remaining exhaust gases. But to incorporate the rotary valve system sometimes creates physical limitations of excessive engine width and unattractive appearance restricting such and engine design.

Yamaha's Research and Engineering Departments, therefore, designed and perfected the 5-port cylinder induction system that is used on the AT1C and CT1C. This new 5-port system, with the incorporation of two additional specially designed transfer ports, completely removes all the exhaust gases previously left in the dead area of the cylinder.

Engine performance is greatly increased with the use of this 5-port system. You, as the owner and rider of the AT1C and CT1C, will benefit from the 5-port system by having increased engine reliability, increased engine performance, and a reduction in gas and oil consumption.

3–2 Construction and Features

The 5-port cylinder induction system is similar to the Schnuerle loop scavenging system in that the two main streams (a) of fresh fuel meet at the cylinder wall opposite the exhaust ports, and deflect upward. Then, the streams again deflect downward, forcing out the burnt gases through the exhaust ports.

Additionally, in the 5-port cylinder induction system, two auxiliary transfer passages are so arranged that these two ports run from the bottom of the cylinder up to the same height as the main transfer ports. Therefore, when the piston comes down to bottom dead center, these two transfer passages are opened and fuel is pushed up from the crankcase to the cylinder through the two holes in the cylinder.

In the conventional Schnuerle system of porting, the burnt gases (b) cannot be completely cleared out of the cylinder, remaining in the center of the combustion chamber.

CYLINDER PORTING – Construction and Features

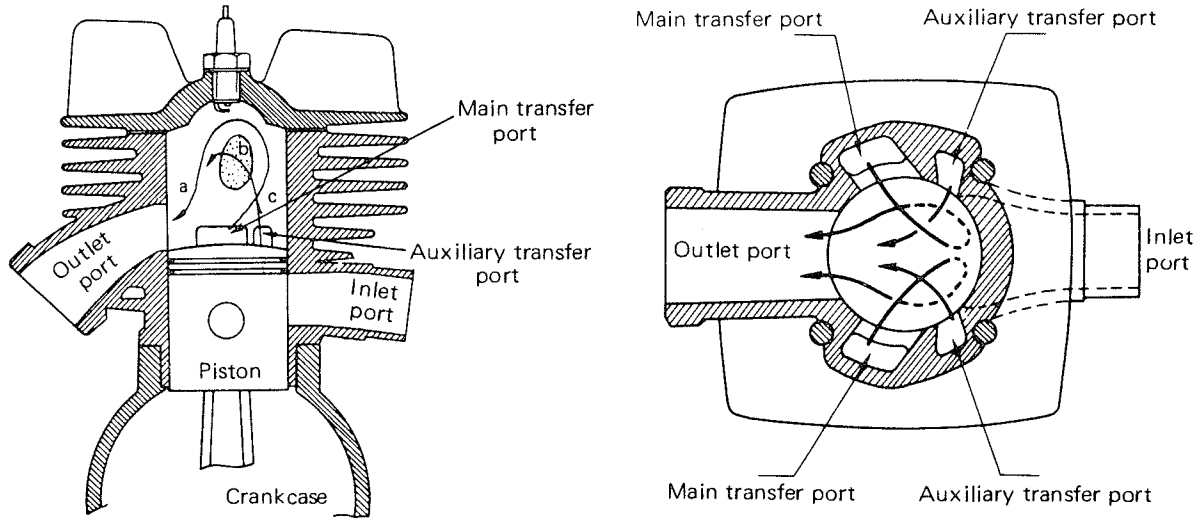

However, the design of the 5-port cylinder induction system has successfully eliminated such a disadvantage; the additional ports are designed to direct their fresh charge (c) at the area containing the remaining burnt gases, completely forcing the exhaust gases out of the cylinder.

Another advantage of the 5-port induction system is that the piston is cooled by the fresh fuel passing over it. This greatly increases the engine power in combination with the new design of 5-port system.

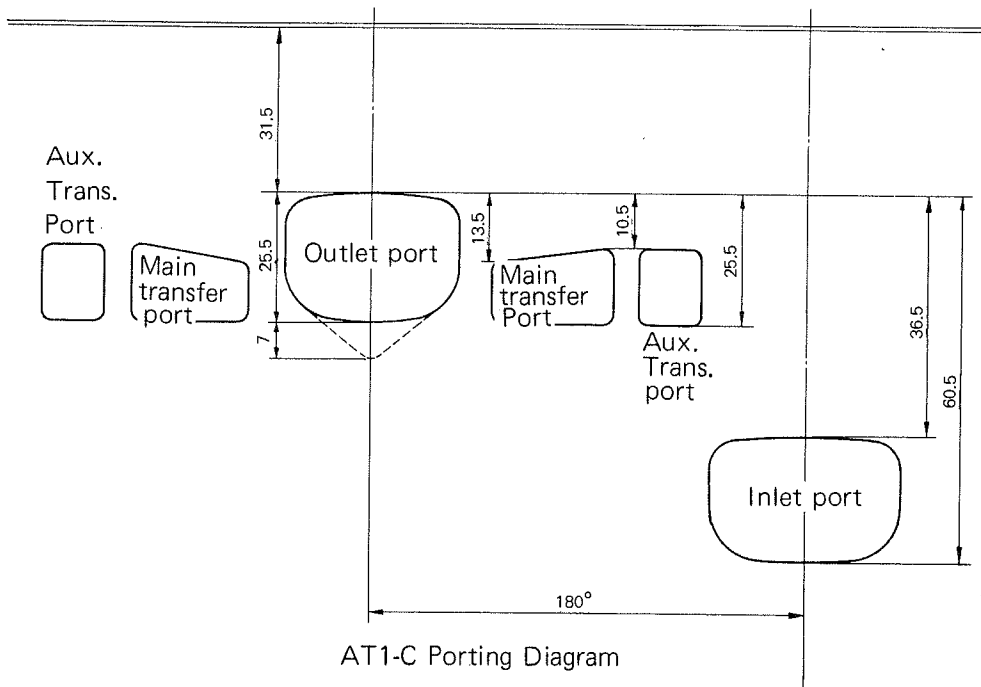

CYLINDER PORTING – Construction and Features

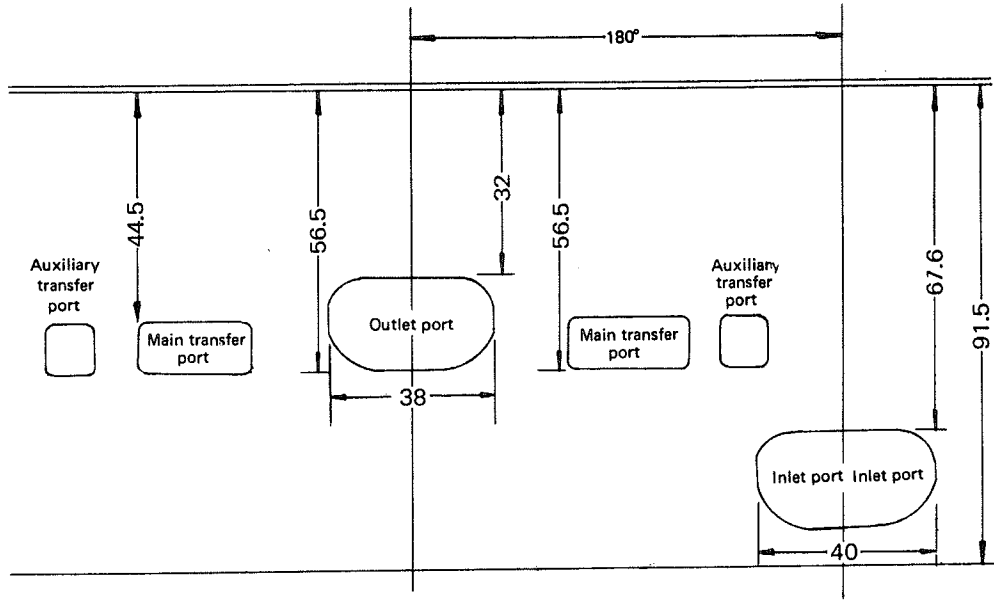

CT1-C Porting Diagram

3-3 The Torque Induction System (7-port cylinder reed valve system)
(LT2, LT3, AT2, AT3, CT2, CT3)

Over six years ago, the engineers at the Yamaha Research Institute took on a problem that has long plagued many riders: how to get more effective horsepower. Riders who buy motorcycles on the basis of advertised high RPM horsepower often find that overall performance is poor. Under heavy loads, many bikes stutter and stall . . . spark plugs foul. The bikes may have high peak horsepower running flat-out, but they lack effective performance overall.

After a thorough study of this problem, Yamaha engineers confronted a fundamental fact: if you want better overall performance, you need a better breathing engine. By "better breathing" we mean the ability of the engine to get the fuel/air mixture it needs when it needs it. Engineers call an engine's breathing process "induction".

Yamaha's answer for "better breathing" is Torque Induction (R). Torque Induction is a unique method for supplying the fuel/air mixture to the engine, based on engine demand rather than an arbitrary mechanical induction system such as the piston skirt or a crankshaft-mounted rotary valve.

With Torque Induction, Yamaha added a unique new 7th port that gives your bike more muscle at the top end. The 7th port improves performance by (1) allowing more fuel/air mixture to be "rammed" into the combustion chamber and (2) by simultaneously improving the "scavenging," or removal, of exhaust gases. The blast of cool fuel/air mixture directly from the carb into the combustion chamber helps cool the engine, and greatly extends piston life.

With Torque Induction, your Yamaha runs cooler and breathes better over its entire RPM range, for roaring response in the dirt and greater peak power on the street.

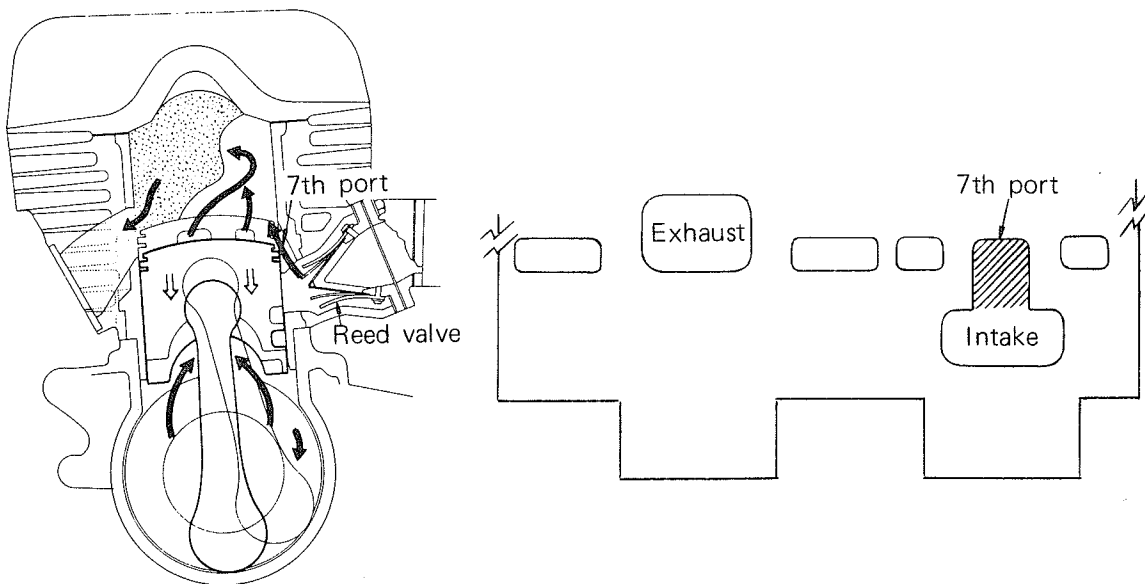

3-4 The YAMAHA Reed Valve

Yamaha has designed a unique stainless steel reed valve located between the carburetor and cylinder. The valve works independently on a demand basis. There's no mechanical device, such as a rotary valve or piston skirt to govern its opening and closing.

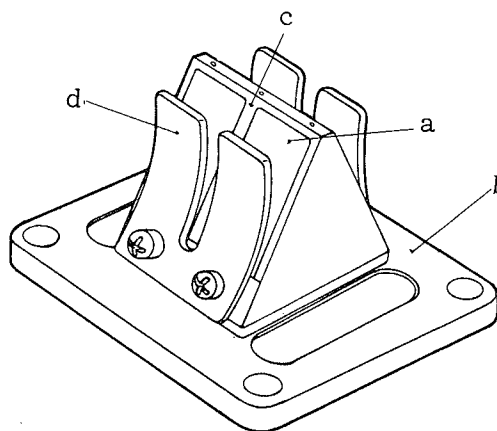

Construction of the Reed valve

a. Valve

The valve is made of special flexible stainless steel and designed to open and close the inlet port.

b. Case

The case is made of a die-cast aluminum alloy.

c. Gasket

Made of heat-and oil-resisting rubber, the gasket is "welded" to the case by heat.

d. Valve Stopper

The valve stopper is made of highly-durable cold-rolled stainless steel plate, and controls the movement of the valve.

Handling of the Reed Valve

As explained earlier, the reed valve is operated by changes in the crankcase pressure and by the inertia effect of the fuel-air stream. It is a high-precision work, and therefore, it must be handled with special care.

a. Storage

The reed valve must be stored in a clean and dry place and must not be exposed to the sun. Particularly, it must be kept free from salt. Avoid allowing your hand to touch the valve.

b. Inspection

(a) Valve

Check the valve for cracks and breakage.

(b) Valve Stopper

The valve stopper limits the movement of the reed valve.

(c) Set-screw

The valve and valve stopper should be fastened with the set-screw. Tightening torque should be correct; otherwise, the valve and valve stopper will be deformed.

Correct tightening torque: 8.0 kg-cm

(d) Gasket

The gasket is "welded" to the case by heat. It should be checked for separation from the case. If the gasket becomes loose, it may fail to achieve a good seal with the valve.

c. Valve Service

The reed valve can not be perfect, if any of its components - valve, valve stopper, gasket case and set-screw is faulty. If so, it is advisable to replace the whole assembly, instead of replacing a faulty part.

3–5 Operation of the Torque Induction System

1. Ignition Power and Exhaust

The piston approaches top dead center, and the spark plug fires. Combustion pressure forces the piston down. As the piston crown passes the exhaust port, exhaust gases begin to flow out.

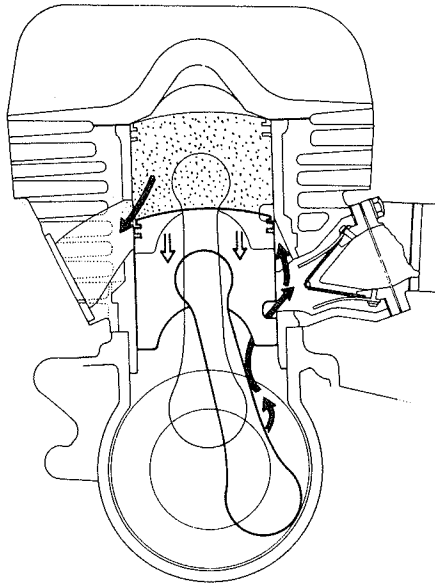

2. Transfer

As the piston continues down, it passes the transfer ports, opening them. They allow the compressed fuel/air mixture in the crankcase to flow into the combustion chamber. All the remaining exhaust gases within the chamber are pushed out by this transfer action.

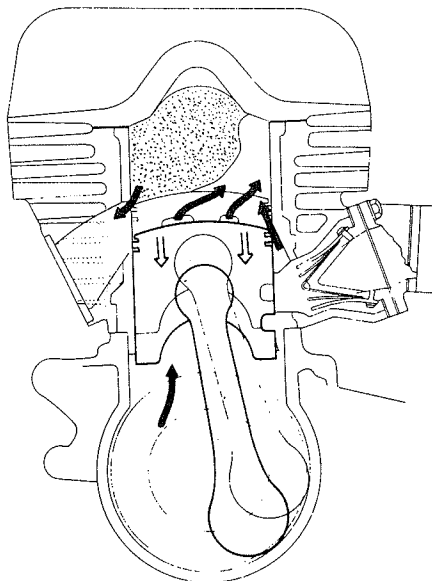

CYLINDER PORTING – Operation of the Torque Induction System

- When the piston starts up, it creates a vacuum within the crankcase. Atmospheric pressure forces the Torque Induction valve open, and a fresh fuel/air charge is rammed into the crankcase.

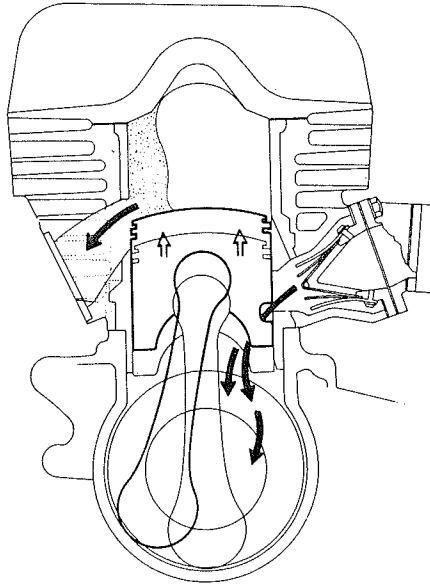

4. Compression

The piston starts up, closing all ports. As it moves up, it compresses the fuel/air charge for ignition. At the same time, the upward movement of the piston creates a suction effect or "demand" in the crankcase.

5. Induction

The "demand" created by the piston traveling upward causes atmospheric pressure to "ram" air into the crankcase. The steel reed valve opens to allow the fuel/air mixture in. This is the real secret behind Torque Induction. There is no mechanically-governed device to arbitrarily open the crankcase - - sometimes at the wrong time. The fuel/air mixture from the carb comes in only when it is wanted.

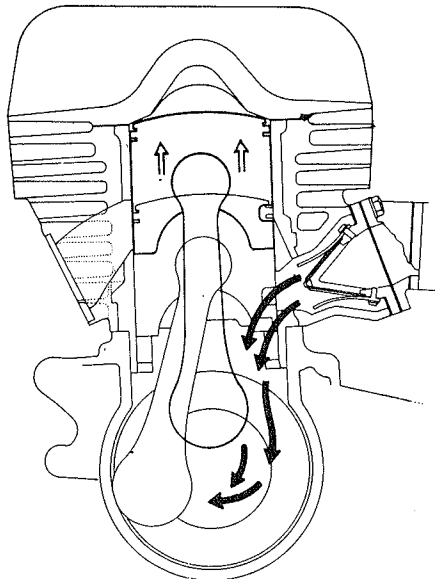

6. Scavenging the 7th Port

On the 5-port cylinder, the auxiliary transfer ports are positioned on the same level as the main transfer ports. As the piston lowers to the position as illustrated, the fuel-air mixture in the cylinder is compressed and is going to stream into the cylinder through the main and auxiliary transfer ports. On the 7-port cylinder, too, the compressed mixture is about to stream into the cylinder through the inlet port of the piston.

As the piston moves down further, the main, auxiliary and 7th ports are cleared and the fuel-air mixture enters the cylinder in streams.

In this case, the inertia effect of the streams causes the reed valve to open, and the fuel-air mixture passing through the reed valve flows directly into the cylinder through the 7th port (the mixture does not enter the crankcase), thereby forcing the burned gases out of the cylinder. This is the scavenging action of the 7th port.

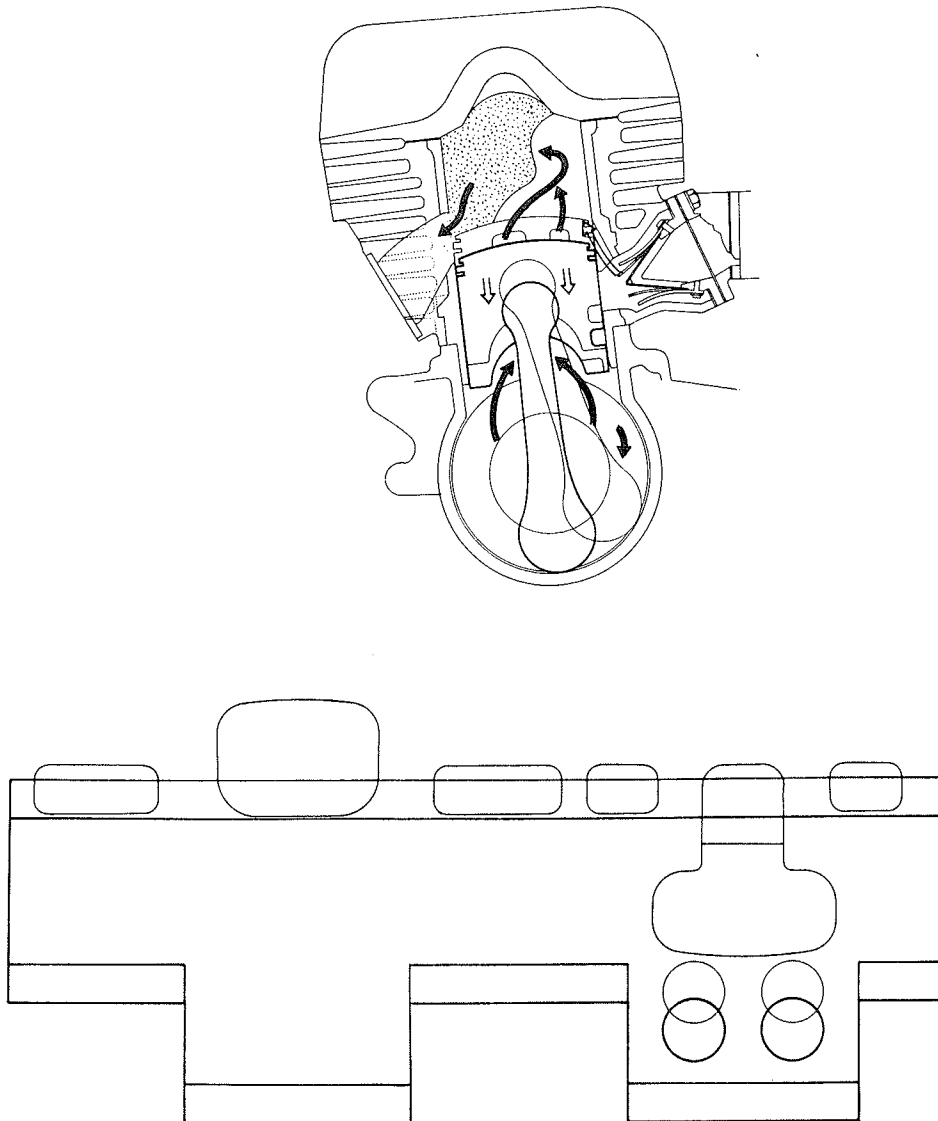

LT2–LT3 Porting Diagram

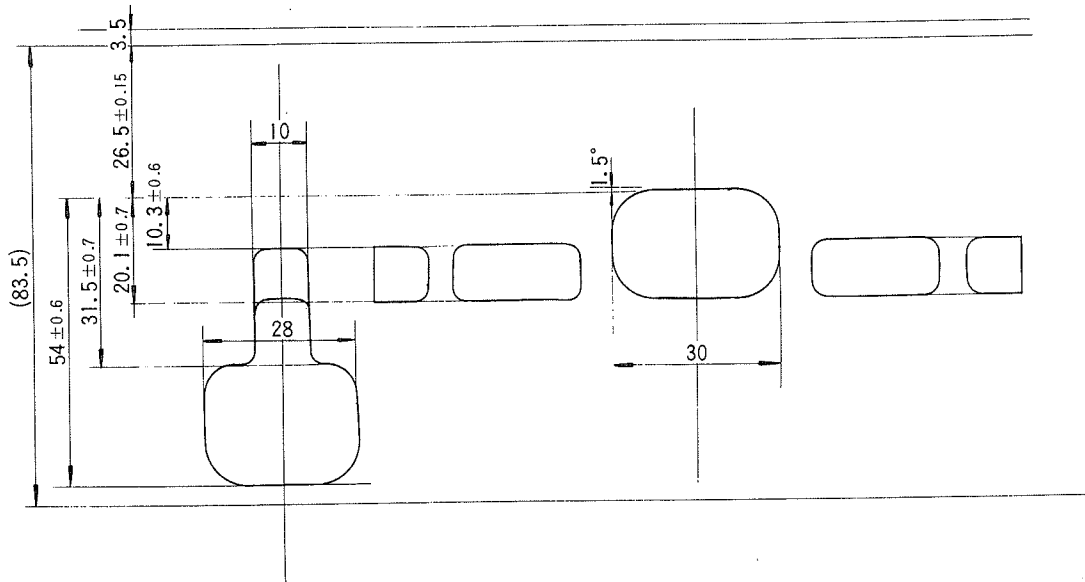

AT2–AT3 Porting Diagram

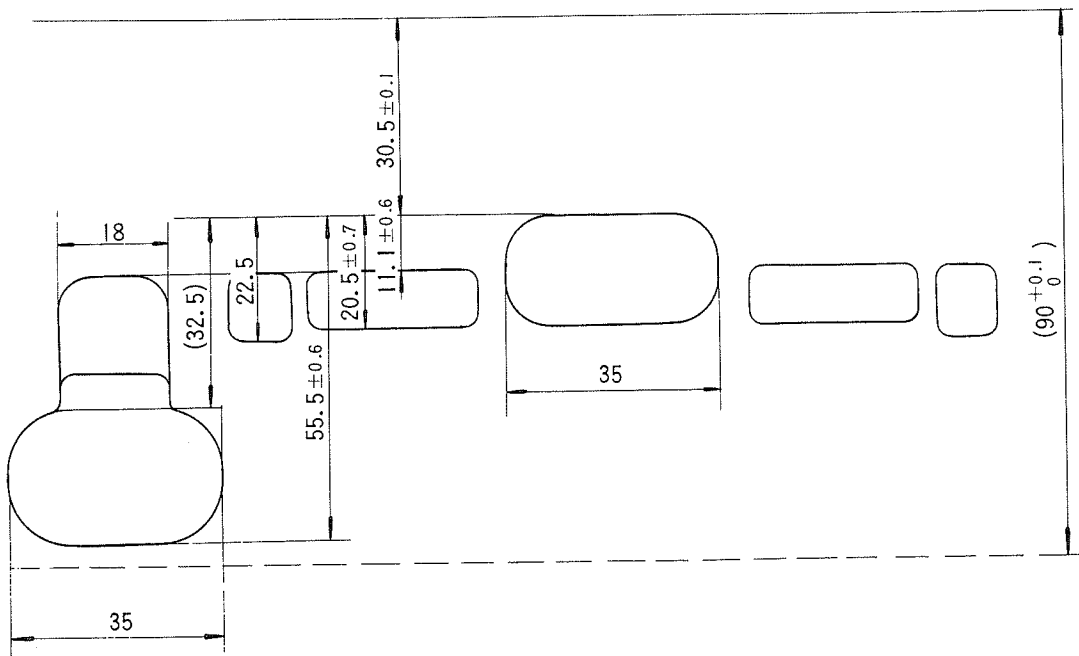

CT2–CT3 Porting Diagram

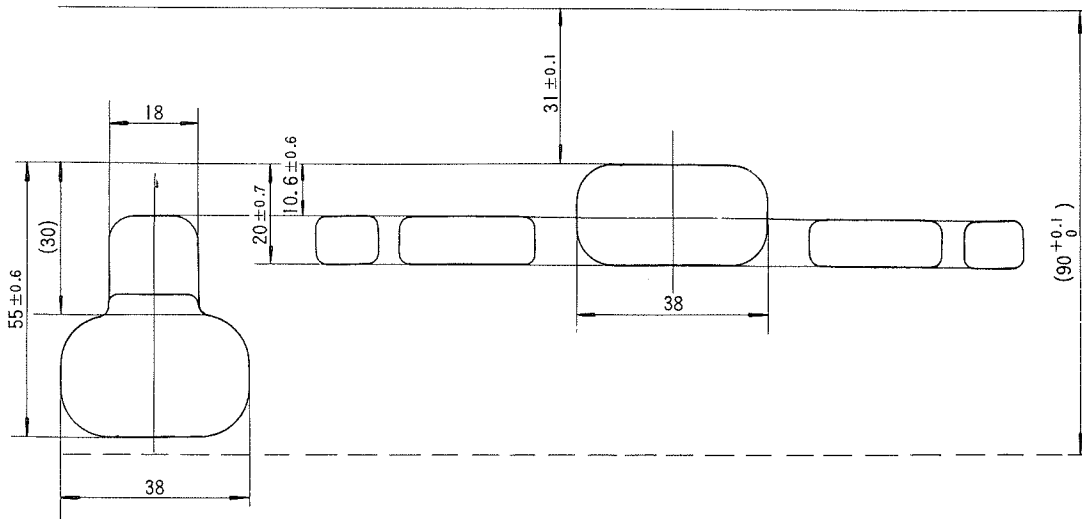

Chapter 4 Engine

This chapter describes the disassembly and reassembly of the engine, its removal from the chassis, and the necessary service data. However, except when overhauling the crankshaft assembly, transmission, shifter mechanism, or bearings and oil seals in the crankcase, it is suggested that engine be serviced without removing it from the chassis. This will save a lot of time and labor.

Preparation for disassembly of the engine:

- 1) All dirt, mud, dust, and foreign material should be thoroughly removed from the exterior of the engine assembly before removal and disassembly. This will prevent any harmful foreign material from entering the interior of the engine assembly.
- 2) Before engine removal and disassembly, be sure you have proper tools and cleaning equipment so you can perform a clean and efficient job.
- 3) During disassembly of the engine, clean all parts and place them in trays in order of disassembly. This will make assembly time faster and easier, and insure correct installation of all engine parts.

4-1 Engine Removal

1. Start the engine and warm it up for a few minutes, then turn off the engine and drain the transmission oil

Amount of oil:	700 c.c. (0.7 USqt.)	– LT2, LT3
(SAE 10W30)	750 c.c. (0.75USqt.)	– AT2, AT3, CT2, CT3
	800 c.c. (0.8 USqt.)	– AT1-C, CT1-C

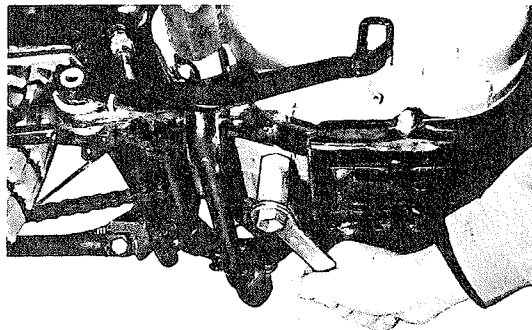

2. Remove the muffler.

1) Remove the two springs and two bolts.

2) Remove the muffler holding bolts,
then the muffler.

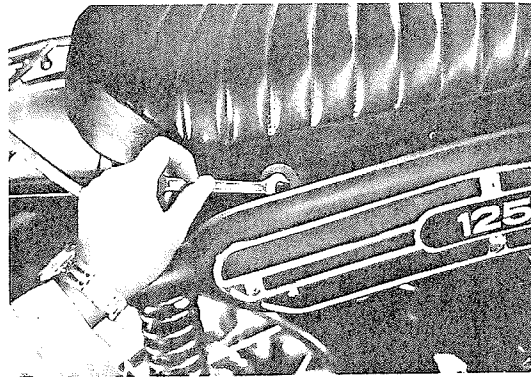
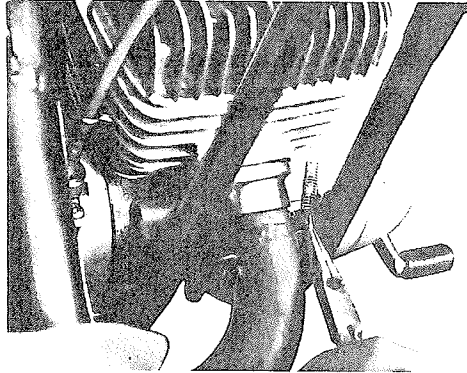

3. Remove the change pedal.

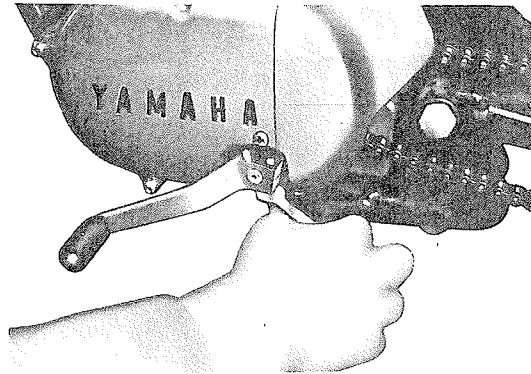

4. Remove the left-hand crankcase cover.

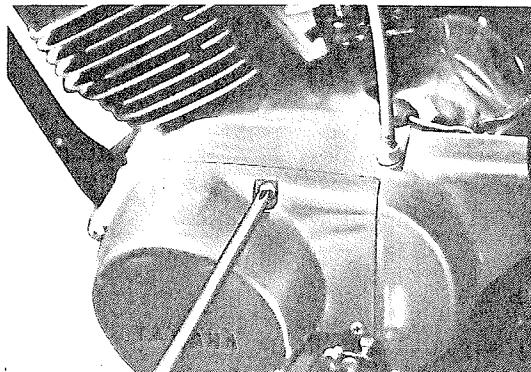

ENGINE – Engine Removal

5. a. On the AT series, equipped with a dynamo, all wire leads should be removed from the starter terminals.

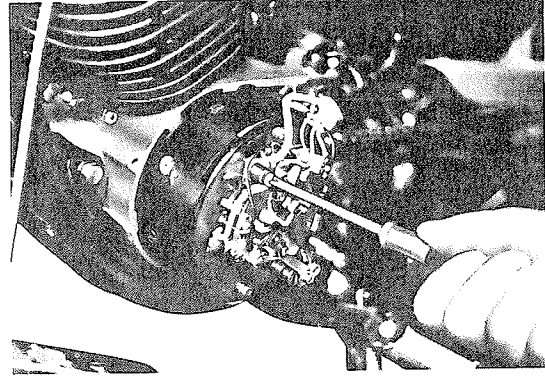

- b. Remove the yoke ass'y.

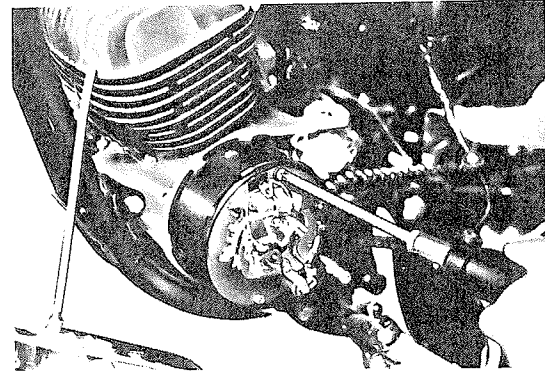

- c. Remove the armature by the use of the armature puller.

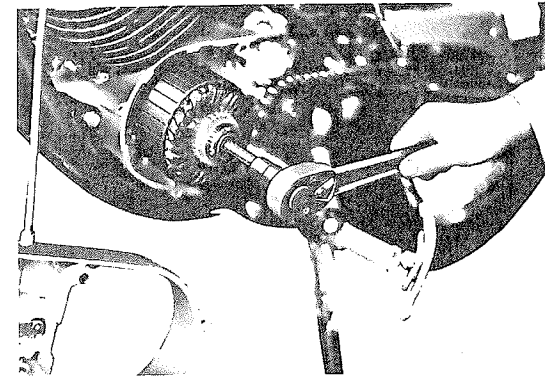

- d. Pry out the woodruff key (segment key) with a slot-head screw driver.

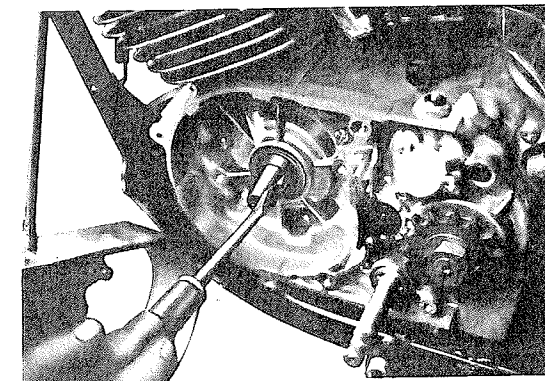

6. a. On the LT and CT series equipped with a flywheel magneto. Remove the flywheel lock nut, washer and flat washer.

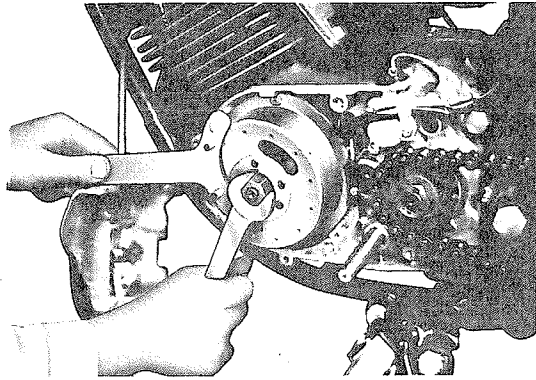

- b. Install the special tool and remove the flywheel.

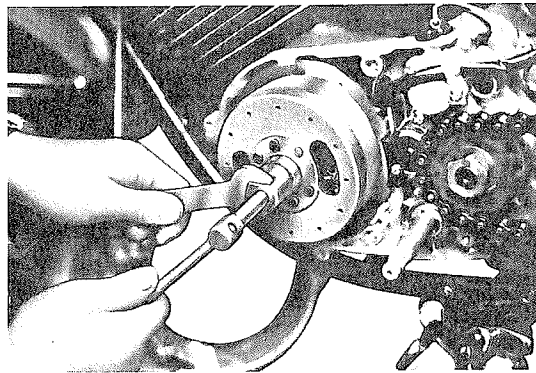

- c. Remove the magneto base, and hold it to the frame with a string.

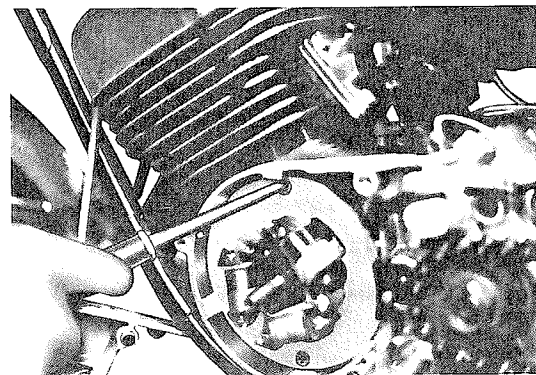

- d. Pry out the woodruff key (segment key) with a slot-head screw driver.

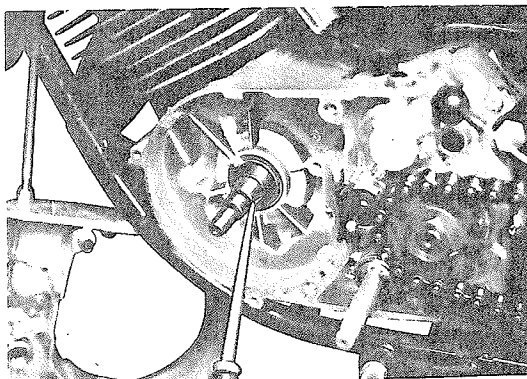

7. Disconnect the master link and remove the chain.

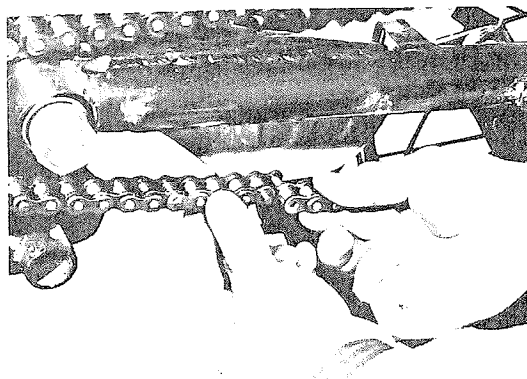

When reconnecting the chain be sure the master link is facing in the correct direction.

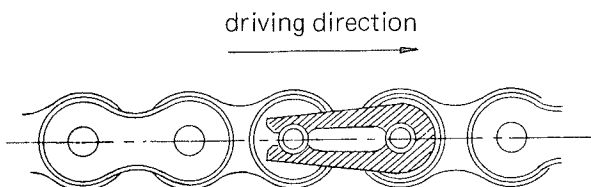

After reconnecting the chain adjust the free play to 25 mm. (1 in.) up and down at the center of the lower section with the rear wheel on the ground.

8. Remove the pump cover and pump cable.

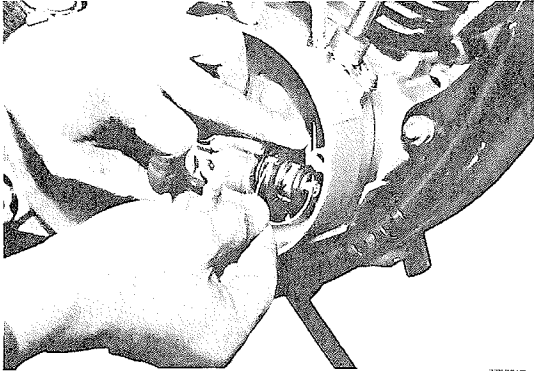

9. Remove the tachometer cable. (AT/CT series only)

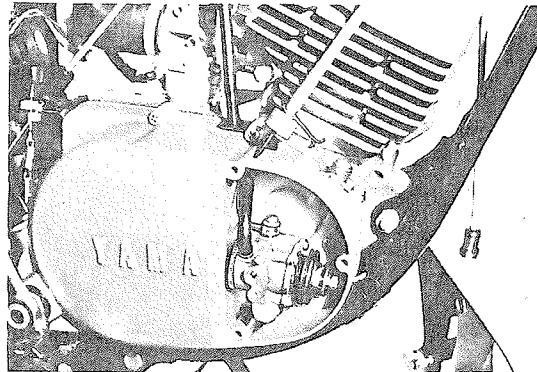

10. Remove the air cleaner rubber and carburetor slide valve.

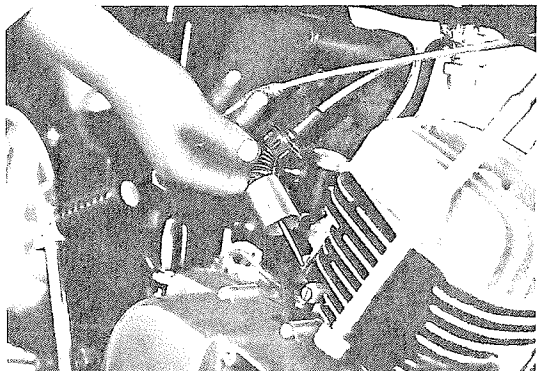
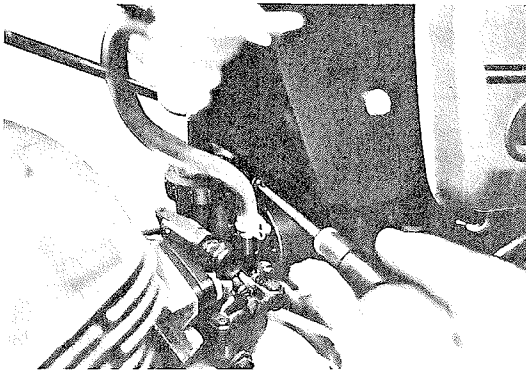

11. Disconnect the oil line and be sure to plug the hole to prevent oil from flowing out.



12. Disconnect the fuel line at the bottom of the fuel tank.

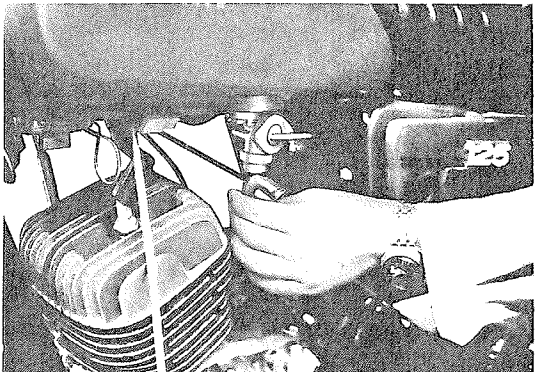

13. Remove the carburetor and three engine mounting bolts.

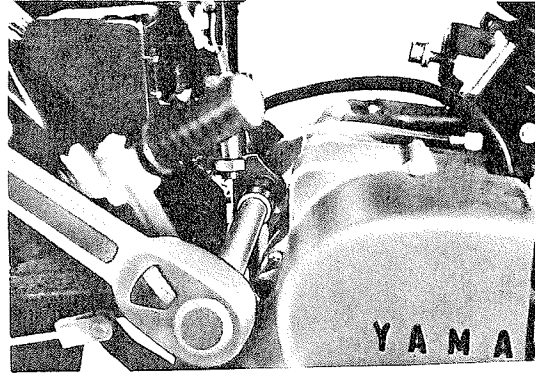
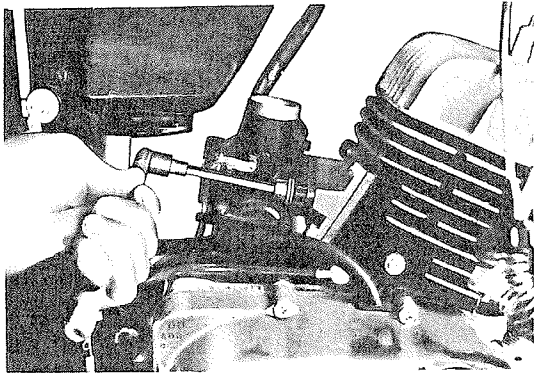

14. Remove the engine from the frame.

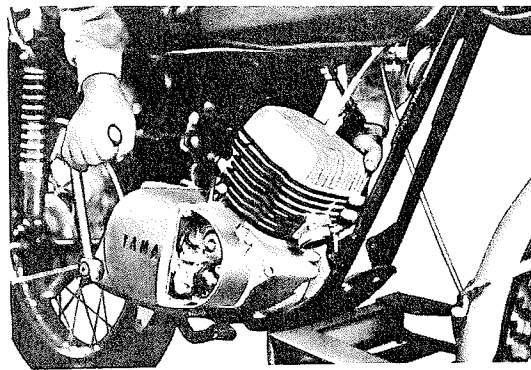

4-2 Cylinder Head

	LT2	LT3	AT1C	AT2	AT3	CT1C	CT2	CT3
Cylinder head volume (C.C.)	11.18	11.18	14.1	14.1	14.1	24.0	24.0	24.0

The cylinder head is bolted on the cylinder with four special nuts.

A. Removing

Remove the four special nuts from the top of the cylinder head, then the head and head gasket. Reverse the sequence for reinstallation. Replace the gasket, if damaged. Cylinder head tightening torque is 15~18 ft-lbs. (2.0 kg-m)

Note: The special nuts should be loosened (and tightened) in a "cross" pattern and in progressive stages.

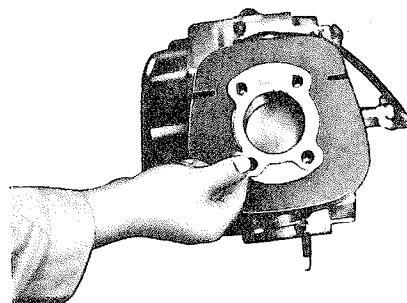
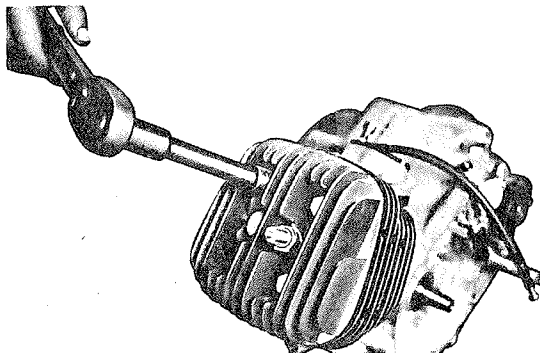

B. Removing Carbon Deposits

Carbon deposits on the cylinder head combustion chamber and top of the piston will result in an increase in the compression ratio, as well as pre-ignition and engine overheating.

Scrape the cylinder head and piston dome clean. Take care not to gauge the material.

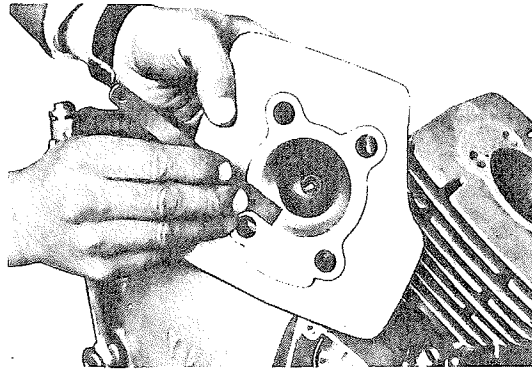

4-3 Cylinder

The Yamaha AT and CT series engines employ an aluminum cylinder sleeved with special cast iron, that provides improved cooling efficiency and light weight. The LT series has a special cast iron cylinder.

NOTE: See cylinder description section for porting specifications.

A. Removing the Cylinder

- 1) Remove the oil delivery line banjo bolt from cylinder.

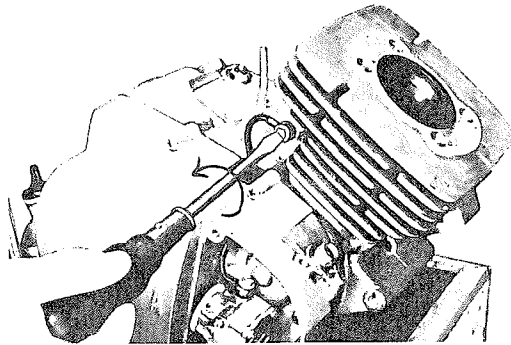

- 2) Remove the cylinder by striking it lightly with a plastic or rubber hammer.

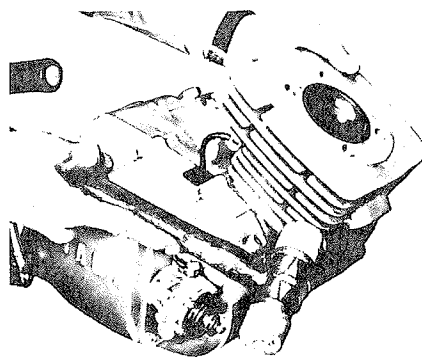

- 3) Always replace the cylinder base gasket when reassembling.

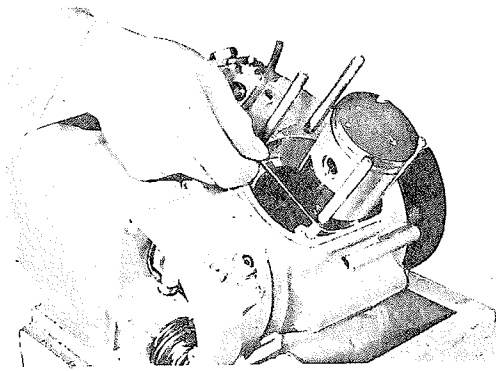

B. Checking the Cylinder for Wear

- 1) Measure the amount of wear of the cylinder wall with a cylinder bore measuring micrometer or cylinder gauge. (Measure it at four depths while positioning the instrument at right angles to the crankshaft.) If the difference between the maximum and minimum diameter exceeds 0.05 mm. (0.0019"), rebore and hone the cylinder.

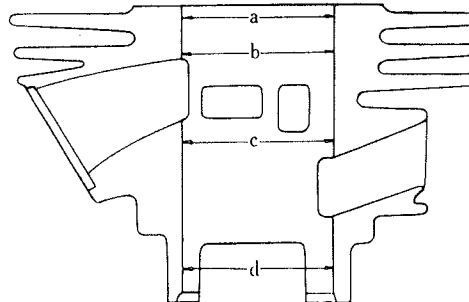
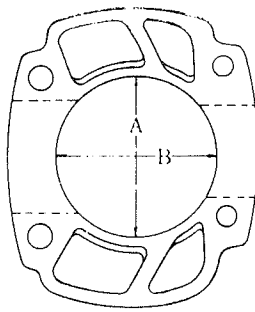

- 2) The standard clearance between the piston and the cylinder is 0.040-0.045 mm. (0.0016" and 0.0018")

C. Cylinder Reconditioning

- 1) Pistons are available in 0.55 (0.010") increment oversizes.

- 2) The cylinder should be rebored and honed to the diameter of the oversize piston plus the standard allowable clearance.
- 3) The error between the maximum and minimum diameters after honing should be no more than 0.04 mm. (0.0015")

D. Removing Carbon Deposits

Scrape off the carbon accumulation in the exhaust port of the cylinder with the dulled end of a hacksaw blade.

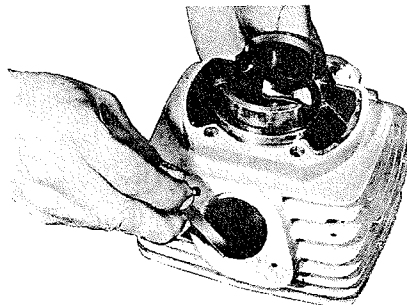

E. Installing the Cylinder

Align the ring ends with the locating pins in each ring groove. Thoroughly coat the rings, piston walls wrist pin and bearing with oil.

Next, insert the piston into the cylinder. Take care not to damage the rings.

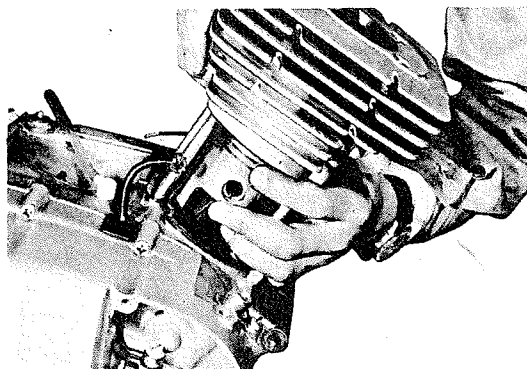

4-4 Piston Pin

A. Pulling out the Piston Pin

Remove the clip at the end of the piston pin with needle nose pliers, and press out the piston pin with a finger or a slot-head screwdriver. Do not drive the pin out.

Note: Before removing the piston pin clips, cover the crankcase with a clean rag, so you will not accidentally drop the clip or other foreign particles into the crankcase.

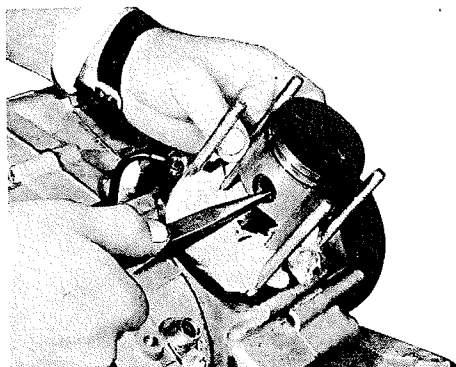

B. Piston-to-Piston pin Fit

The piston pin should fit snugly in its bore so that it drags a little as you turn it. If the piston pin is loose, replace the pin and/or the piston.

If the center of the pin is step-worn, replace the needle bearing as well as the piston pin. Check the small end of the connecting rod for wear by inserting the piston pin and bearing.

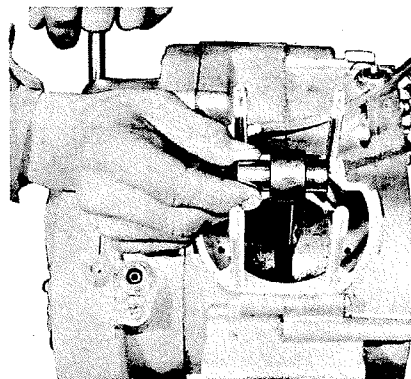
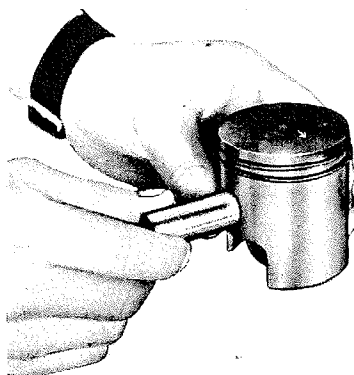

4-5 Piston Ring

A. Removing the Piston Rings

Put your thumbs at each end of the piston ring and pull the piston ring ends apart. Remove the ring by moving the ring off the piston on the other side of the ring ends.

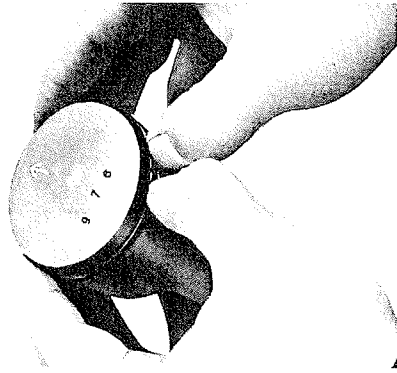

B. Installing the Piston Rings

First fit No.2 ring over the piston, and then the No.1 ring (Keystone ring) and align their end gaps with the locating pin in each ring groove.

The printing on all rings must face up to position the gap properly at the pin.

C. Piston Ring Expander

Piston ring expanders are sometimes used to increase contact pressure between piston ring and cylinder wall. In cases where expanders are used, the expander with the double bend is on the bottom. See drawing right.

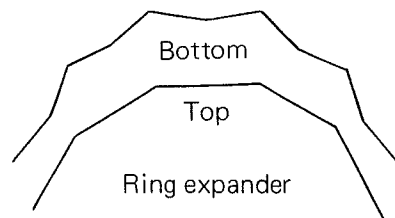
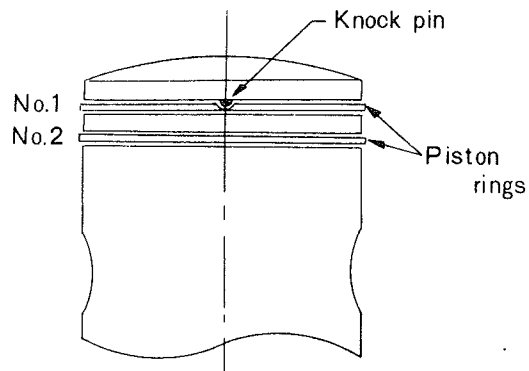

D. Checking the Piston Rings

1) Measuring piston ring wear

Put the ring into the cylinder so that the ring is parallel to the cylinder bottom edge, and then measure the end gap with a feeler gauge

End gap

AT1-C, CT1-C, LT2, & LT3:	0.15~0.35 mm (both No.1 and No.2)
CT2 & CT3:	0.20~0.40 mm (both No.1 and No.2)
AT2 & AT3:	0.30~0.50 mm (both No.1 and No.2)

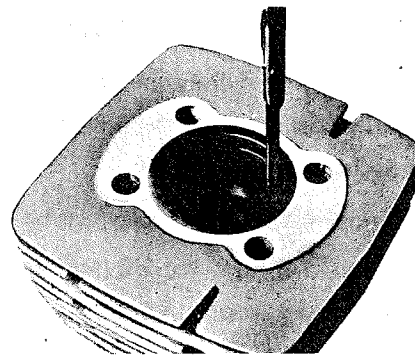

2) Removing carbon

Carbon on the piston rings and in the ring grooves will make the rings stick in the piston, thus causing gas blow-by.

Remove the rings from the piston, and clean the carbon from the rings and ring grooves.

4-6 Piston

The piston is made of a high-silicon aluminum alloy.

A. Checking and Correcting the Piston-to-Cylinder Wall Clearance

1) Measuring piston clearance

Piston clearance is the difference between the minimum cylinder bore diameter and the maximum outside diameter of the piston. As described in 4-3 Cylinder, piston clearance should be 0.040~0.045 mm. (0.0016-0.0018 in.)

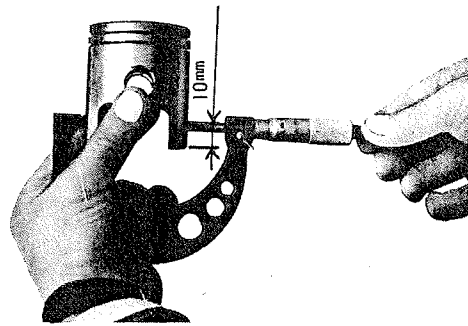

To determine the maximum piston diameter, measure the piston with a micrometer at right angles to the skirt 10 mm. (3/8 in.) from its bottom edge.

2) Checking and correcting scratches on the piston

A piston showing signs of seizure will result in noise and loss of engine power. It will also cause damage to the cylinder wall.

If a piston that has seized is used again without correction, another seizure will develop in the same area. Lightly sand the seizure "high spot" on the piston with #400 sandpaper until smooth.



3) Removing Carbon

Remove carbon accumulations on the piston crown, using a screwdriver or a saw-blade.

Carbon and gum accumulations in the piston groove will result in piston ring seizure.

Remove them from the ring grooves.

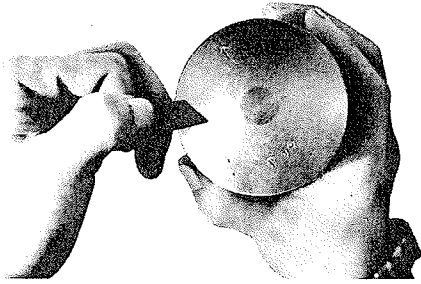

B. Piston Installation Direction

Install the piston with the arrow mark on the head pointing forward (toward the exhaust port of the cylinder).

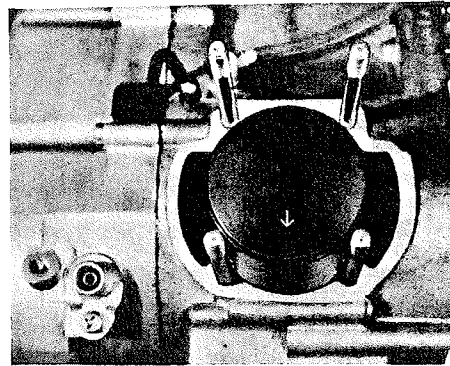

4-7 Crankcase Cover (R.H)

A. Removal

- a) Remove the kick crank mounting bolt and the crank.

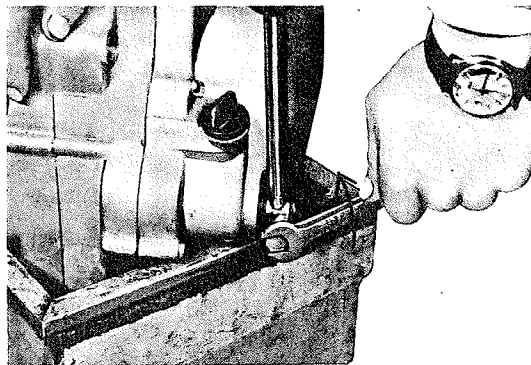

- 2) Remove the pan head screws holding the crankcase cover, and then remove the case cover. (The cover can be removed without taking off the oil pump.)

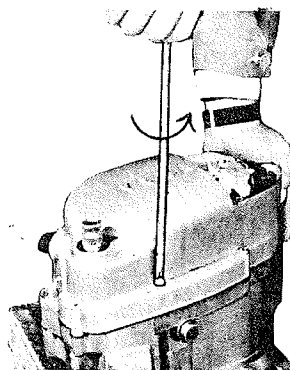

- 3) Remove the crankcase cover gasket. Replace it, if damaged.

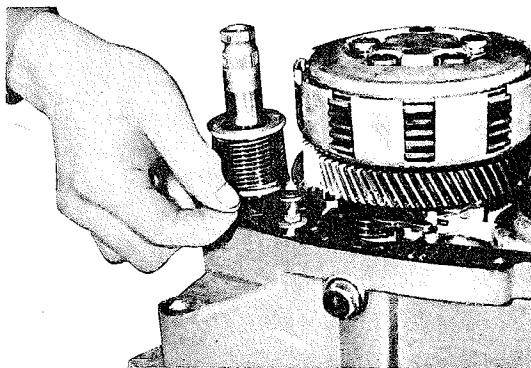

B. Installation

Spread YAMAHA Bond No.5 over the mating surface of crankcase(R). Place the crankcase cover gasket on the crankcase and apply Yamaha Bond No.5 and replace crankcase cover(R). Be sure to apply YAMAHA Bond No.5 to the mating surface; otherwise, Oil will leak.

Note: When installing the crankcase cover(R), make sure that the pump drive gear (made from synthetic resin) is correctly engaged with the primary drive gear.

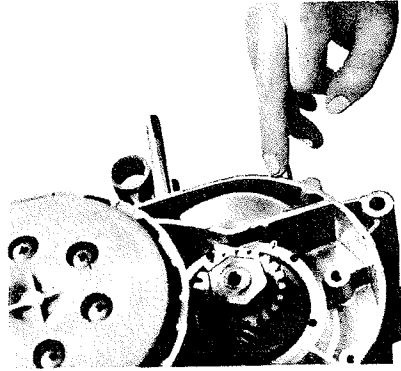

4-8 Clutch

The clutch is a wet, multi-disc type, consisting of five (four on LT series) molded cork friction plates and five clutch plates in the clutch housing that is mounted on the transmission main axle. To disengage the clutch, an inner push rod system is employed. The primary driven gear, coupled with the clutch housing, is meshed with a kick pinion gear. This allows the kick starter to be operated with the clutch disengaged or engaged.

A shock absorber consisting of rubbers is between the primary driven gear and the clutch housing.

The primary drive gear has 19 teeth, and the primary driven gear 74 teeth.

(Primary reduction ratio $74/19=3.894$)

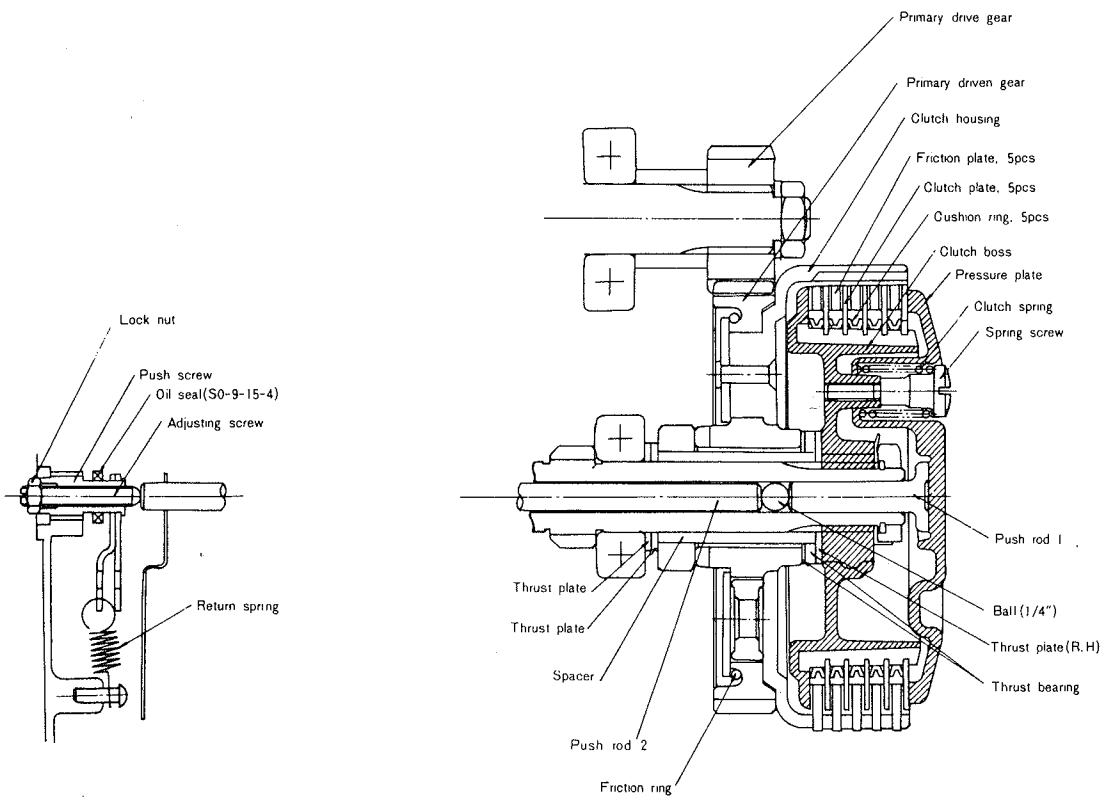

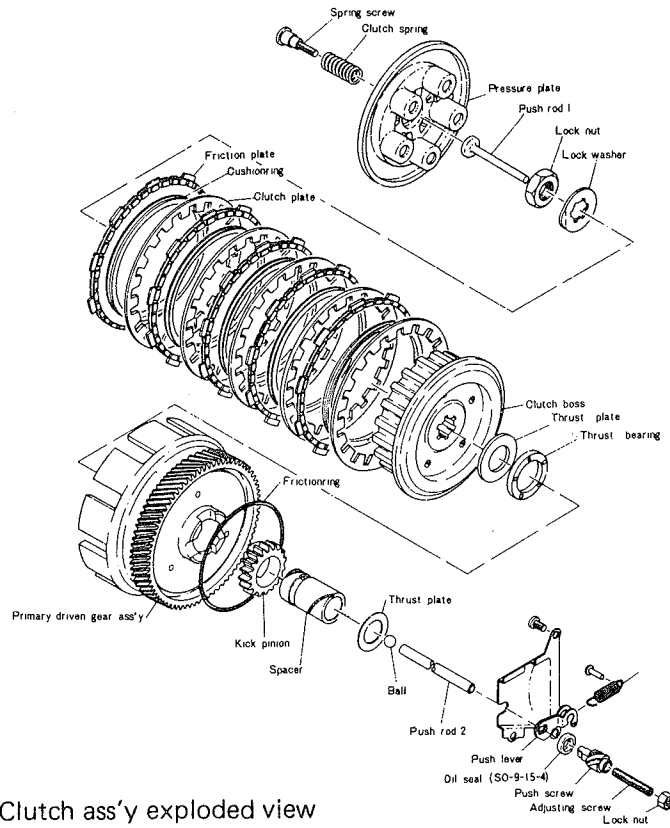

Clutch ass'y exploded view

A. Removing the Pressure Plate

Remove the five clutch spring holding screws, and take out the pressure plate and push rod #1.

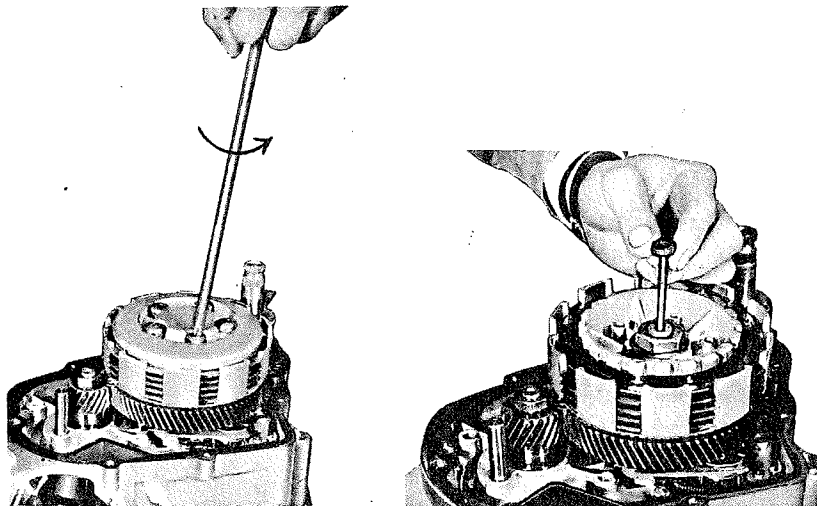

B. Removing the Clutch Boss

Install the clutch holding tool on the clutch boss.

Loosen the lock nut, and then remove the clutch boss assembly.

Tightening torque: LT series 4.0~4.5 kg-m
 AT, CT series 5.8~7.0 kg-m

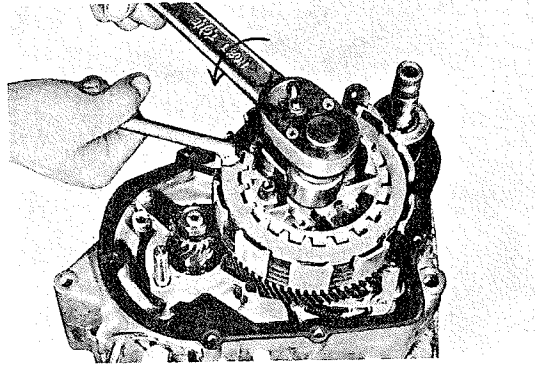

C. Checking the Clutch Spring

If the free length of the spring is 1 mm. (0.04 in.) or more shorter than the standard free length, replace it.

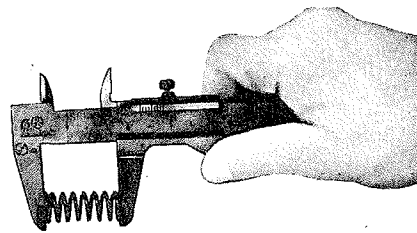

Free length:

LT Series – 34.0 mm. (1.338 in.)

AT/CT Series – 31.5 mm. (1.240 in.)

D. Checking the Friction Plates

Inspect the friction plates for wear. Replace them if they show 0.4 mm. (0.157 in.) or more wear-or uneven contact.

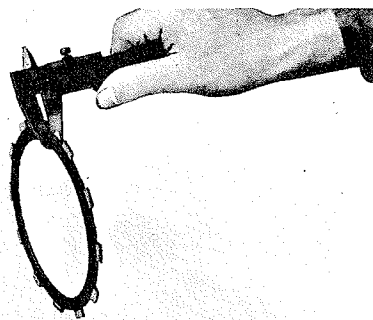

standard thickness 4.0 mm. (0.157 in.)

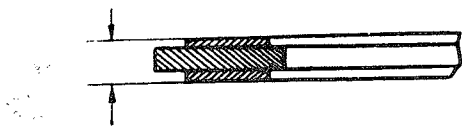

E. Clutch Housing Assembly (integrated with the primary driven gear).

There is a rubber damper ring placed on the outside of the clutch between the primary driven gear and the clutch housing in order to reduce gear noise at low engine speeds.

1) Inspection

Insert the primary gear retaining collar (spacer) in the primary driven gear boss and check it for radial play. If the play is excessive, replace the gear retaining collar because it will cause excessive noise.

If any scratches are found, replace the spacer to avoid impaired clutch action.

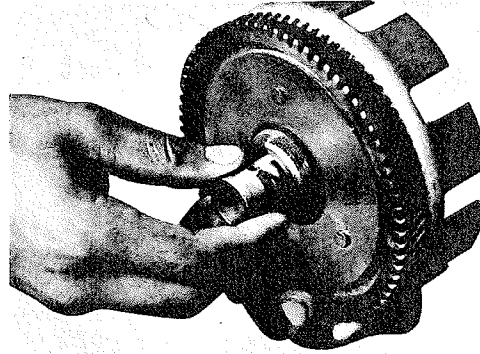

F. Checking the Primary Gear Retaining Collar (Spacer)

Place the primary gear retaining collar around the main axle and again check it for radial play. If play exists, replace the gear retaining collar.

Replace any collar with step-wear on its outer surface.

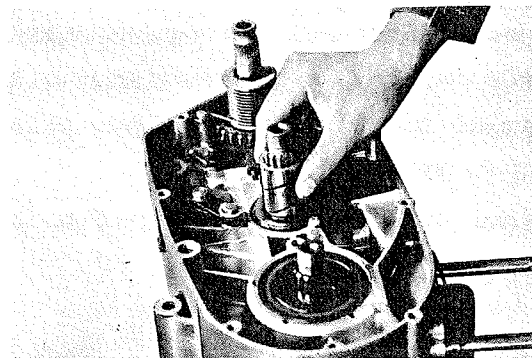

G. Fitting Cushion Rings

A cushion ring is installed between the clutch boss and each of the friction plates to insure even engagement and complete disengagement of the plates. When fitting cushion rings, be sure they are flat and not twisted.

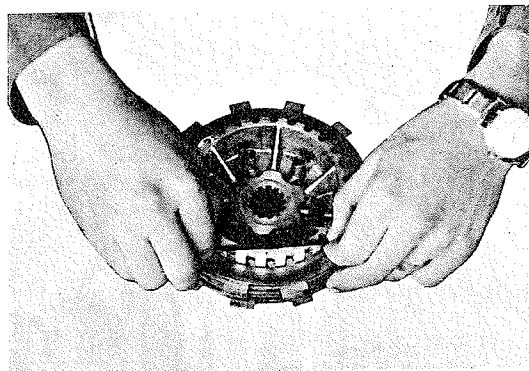

H. Checking the Push Rod

Remove the push rod #2 and roll it over a surface plate. If the rod is bent, replace it.

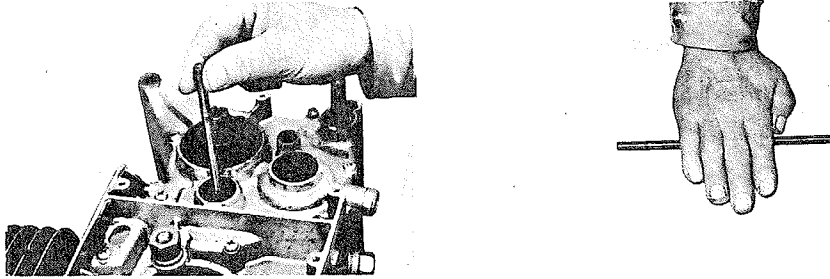

I. Caution on Re-assembling the Clutch

- * On both ends of the primary gear spacer are thrust washers and thrust bearings. If these washers and bearings are incorrectly installed, or omitted, the clutch boss will rub directly on the primary driven gear, impairing clutch action.
- * The thrust bearing fits on the primary retaining collar, but it may slip out of place when installing clutch boss. Therefore, apply grease to both surfaces of the bearing to make it stick to the gear retaining collar.

Before fitting the clutch boss, install the clutch plates, friction plates, etc., and then install the clutch boss.

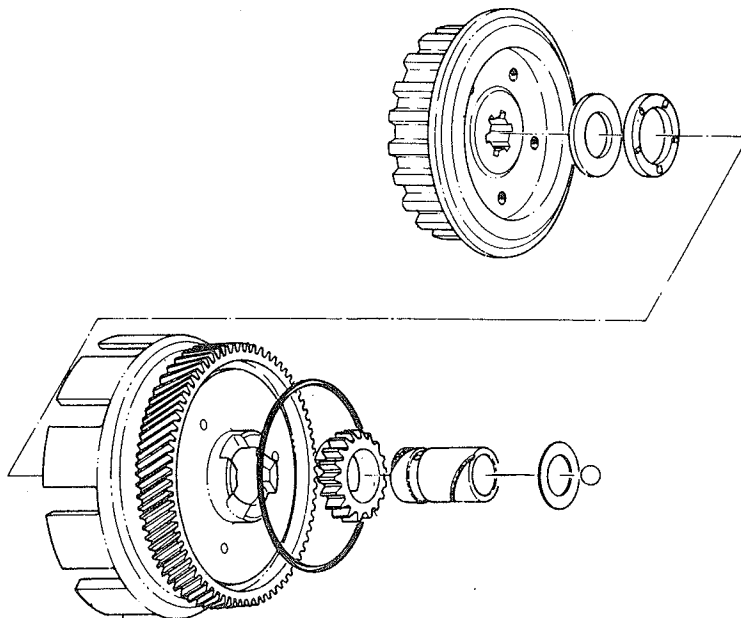

J. Adjusting the Clutch

a) Setting the Adjusting Screw

Turn the adjusting screw in until it lightly seats against the push rod.

Next, back the screw off 1/4 turn to get the proper spacing, then tighten the lock nut.

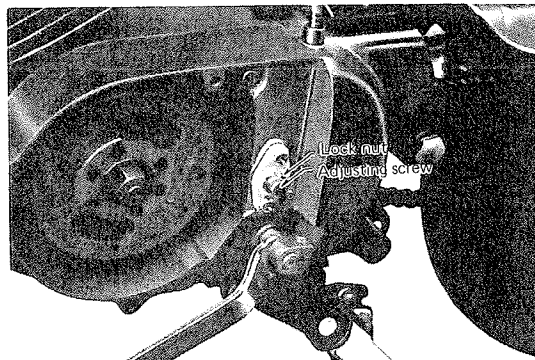

2) Adjusting the Clutch Cable Tension

The clutch cable becomes slackened after being used for a long time.

Occasionally the cable must be adjusted so that the play at the clutch handle is from 2 to 3 mm.

(1/16~1/8 in.)

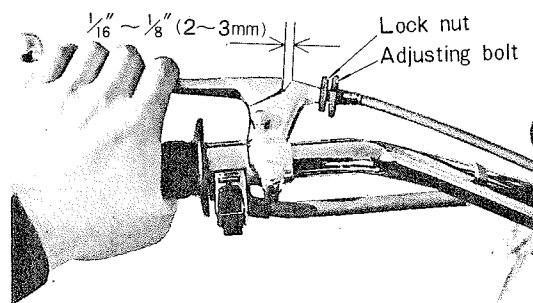

4-9 Primary Drive Gear

A. Removal

Feed a rolled-up rag between the teeth of the primary drive gear and the primary driven gear to lock them, and loosen the primary drive gear lock nut. The primary gear can then be forced off by using two screwdrivers.

Tightening torque: LT series 4.0~4.5 kg-m
 AT, CT series 5.8~7.0 kg-m

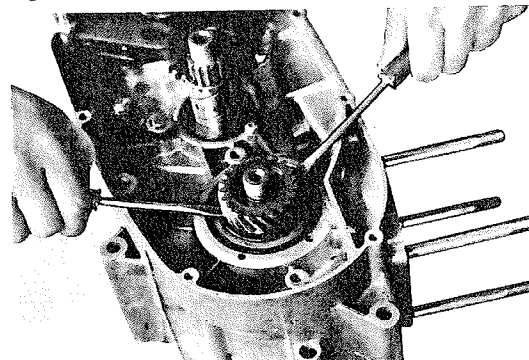
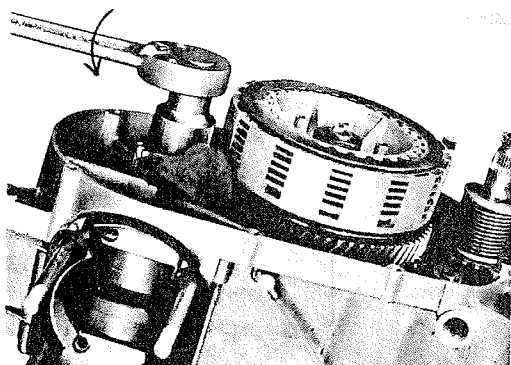

4-10 Kick Starter Mechanism

The primary kick-starter system (one-touch kick-starter) is employed. However, a new "non-constant-mesh" mechanism has been introduced, instead of the constant-mesh kick gear type, such as the ratchet and roller-lock systems.

That is, the kick gear meshes with idler gear only when the kick starter pedal is kicked. After the engine has started, the kick gear and the idler gear disengage.

This mechanism not only eliminates noise resulting from the constant mesh of the kick gear with the idler gear, but also greatly contributes to the durability of the kick starter assembly.

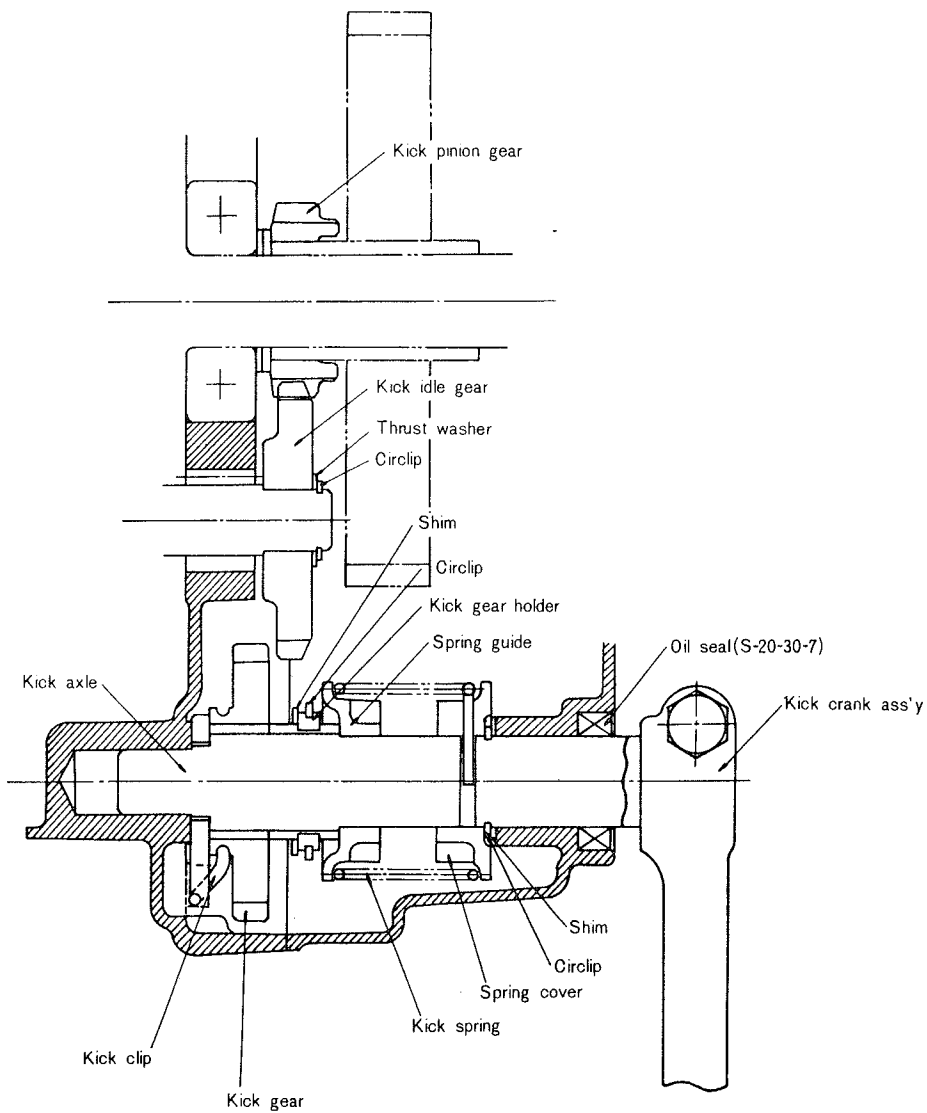

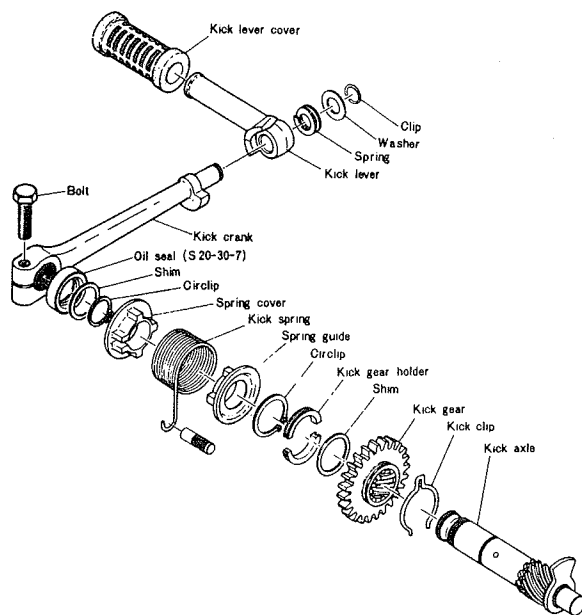

A. Removal

1) Remove the kick spring.

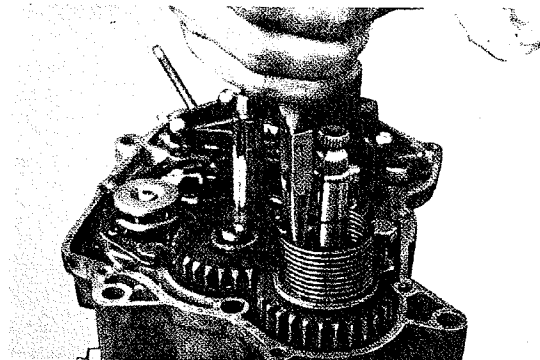

2) Then remove the kick starter assembly.

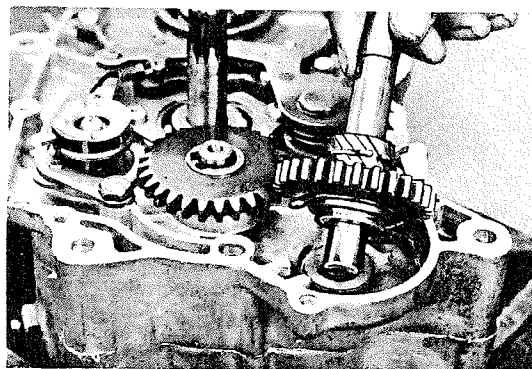

B. Removing the Kick Idler Gear

Remove the circlip with clip pliers.

Then the kick idler gear can be easily removed.

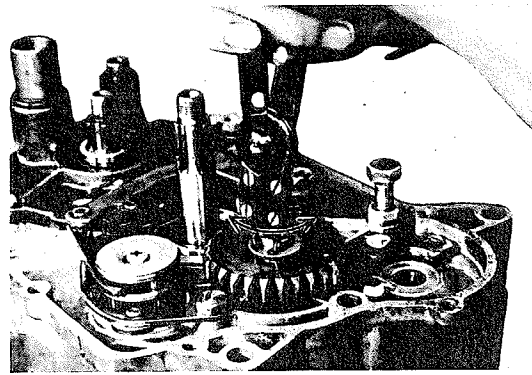

C. Tachometer gear units (AT CT Series only)

The tachometer drive gear is engaged with the primary drive gear to convey the revolutions per minute of the crankshaft to the tachometer through the tachometer cable.

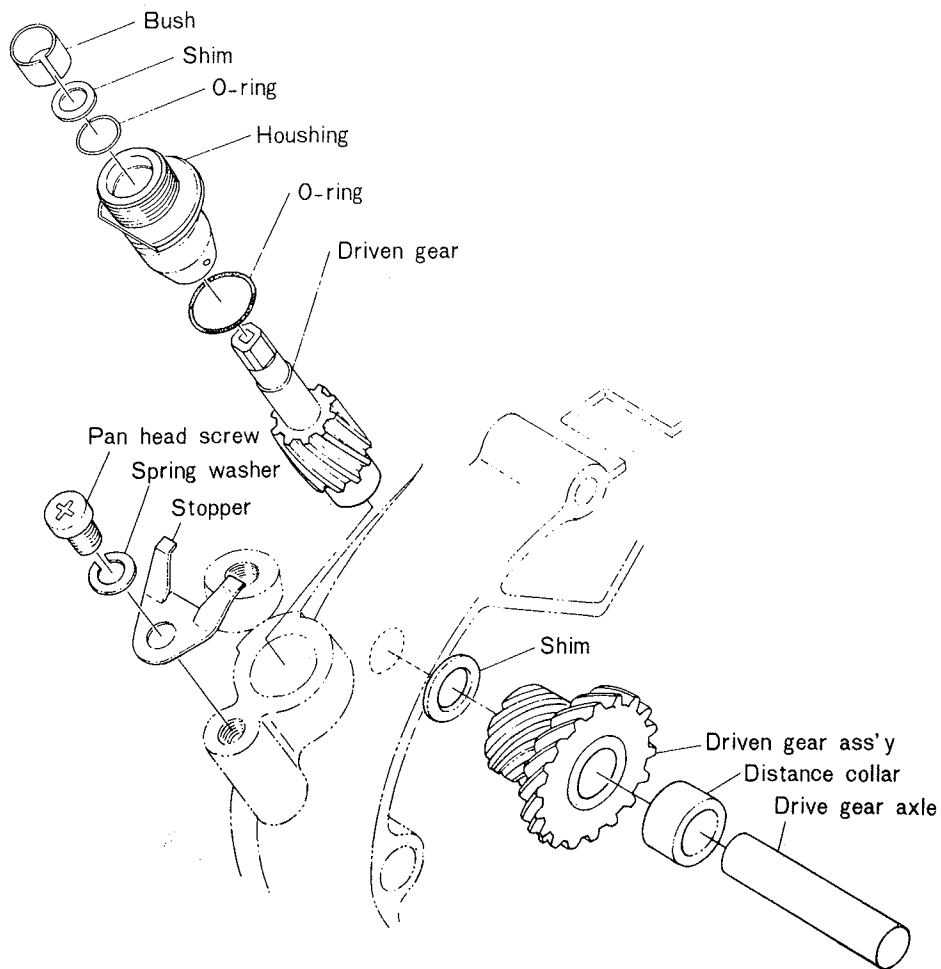

4-11 Shift Mechanism

The shift mechanism is operated in five stages by a see-saw type change pedal. As the change pedal is depressed, gear shift arm B moves gear shift arm A, which in turn pushes on one of the gear shift pins attached to the gear shift drum, thereby turning the gear shift drum. A total of five gear shift pins are attached to the drum, and therefore, each time the change pedal is depressed, the drum rotates 1/5 of a revolution.

That is, one full turn of the gear shift drum is made in five stages; 1st, 2nd, 3rd, 4th and 5th. Slotted guides are grooved in the shift drum, and the shift fork cam follower pins are placed in these slotted guides. Therefore, as the drum turns, the shift forks slide back and forth in the slotted guides. Shift fork (1) moves the 2nd and 3rd gears, shift fork (2) the 1st gear, and, shift fork (3) moves the 4th and 5th gears.

The neutral position is located between 1st and 2nd gears, and the neutral stopper mechanism is located on the left side of the shift drum.

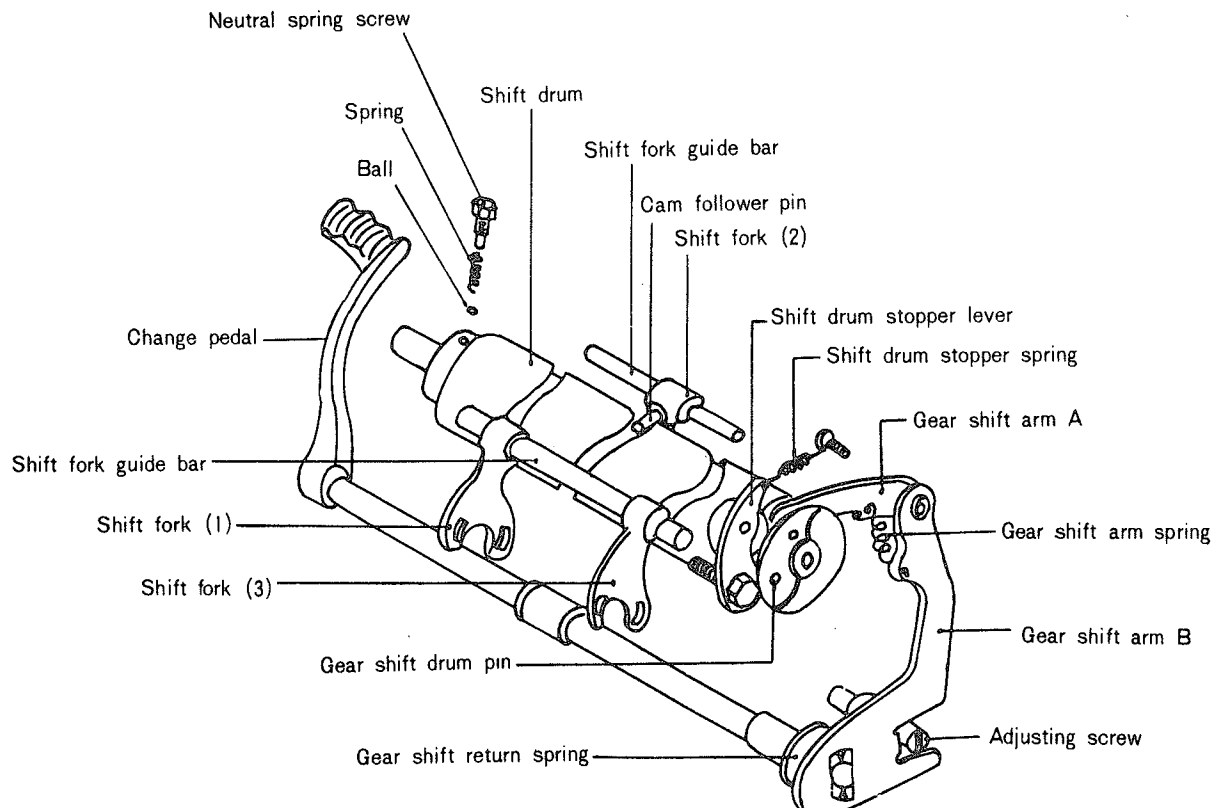

A. Removing the Change Axle Assembly

- 1) Remove the circlip and washer from the change axle (left side crank case).

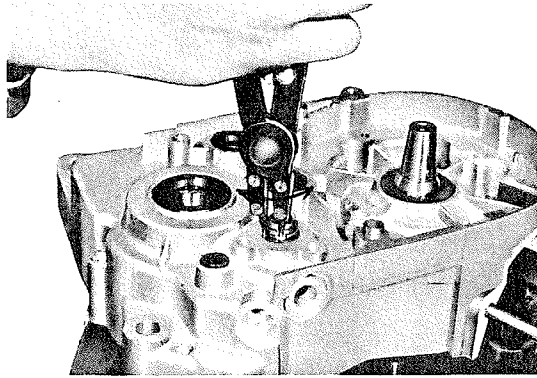

- 2) Turn the engine over, right side up, and pull out the change shaft assembly.

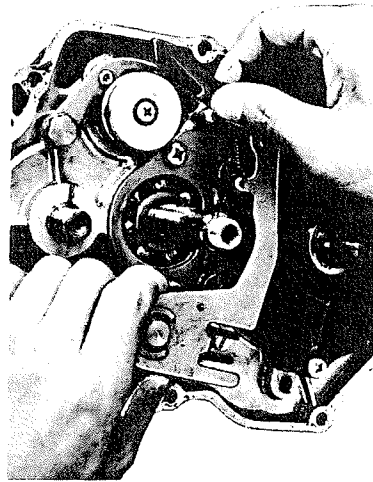

B. Checking the gear shift parts

Checking the Gear Shift Return Spring.

A broken or fatigued gear shift return spring will impair the return action of the shifting mechanism.

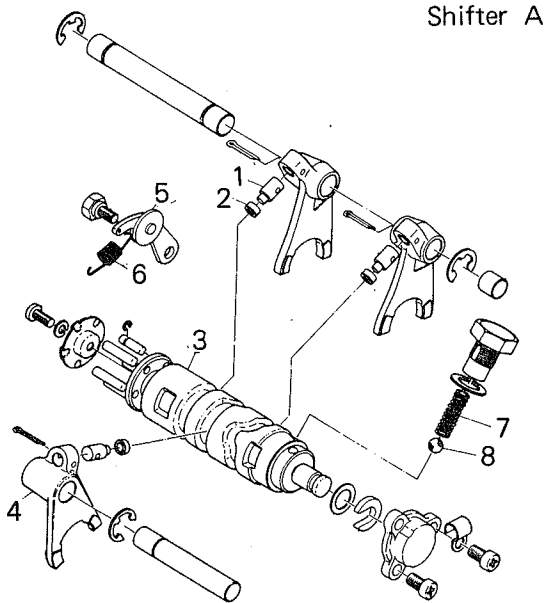

Shifter A

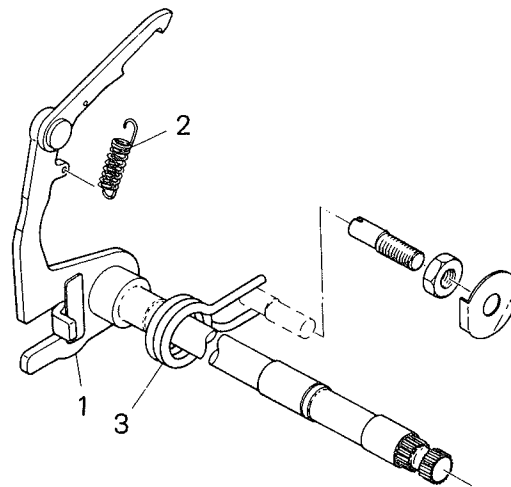

Shifter B

- | | |
|---|---------------------|
| 1 | Cam follower pin |
| 2 | Cam follower roller |
| 3 | Shift cam |
| 4 | Shift fork |

- | | |
|---|---------------------|
| 5 | Stopper lever ass'y |
| 6 | Stopper spring |
| 7 | Neutral spring |
| 8 | Ball (5/16") |

- | | |
|---|---------------------|
| 1 | Change shaft ass'y |
| 2 | Shift arm spring |
| 3 | Shaft return spring |

C. Adjusting the gear shift arm

Adjusting or correcting the travel of the gear shift arm to prevent improper shifting progression (excess feed or insufficient feed of the gear shift arm) is accomplished by turning the gear shift return spring stop screw (eccentric bolt) in or out. Adjust the eccentric bolt until distance A and A' are equal. Adjust in 2nd, 3rd, or 4th gear.

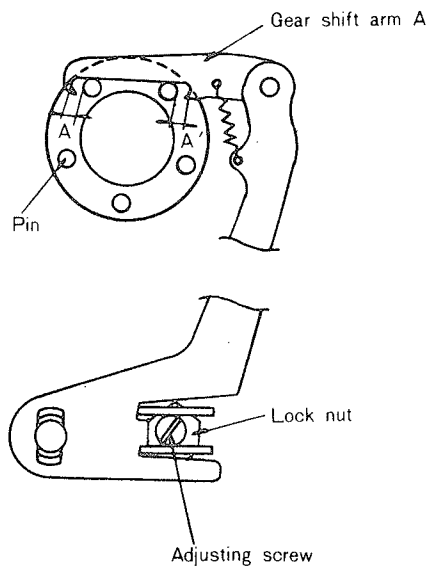

4-12 Drive Sprocket

A. Removal

1) Straighten the bent edge of the lock washer with a blunt-ended metal punch.

2) Hold the drive sprocket with the flywheel magneto holding tool, and remove the sprocket nut. If the flywheel magneto holding tool is not available, shift the transmission to low gear, and fit a monkey wrench on the sprocket nut. Then tap the handle of the wrench with a hammer and the shock will loosen the nut.

Tightening torque: 5.8~7.0 kg-m

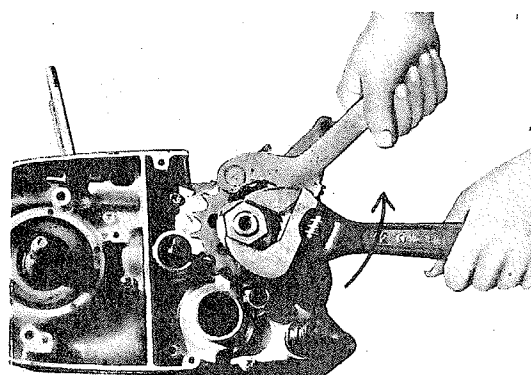
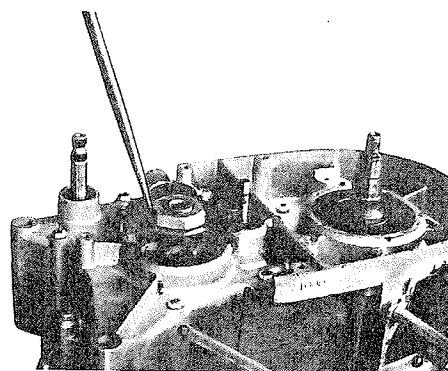

- 3) Remove the distance collar with pliers.
(When reinstalling the distance collar, apply grease to the oil seal lip groove.)

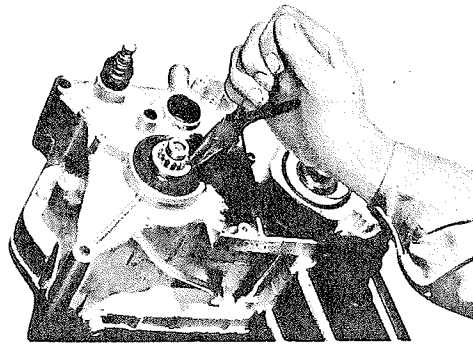

B. Inspection

A worn drive sprocket will result in excessive chain noise and shorten the life of the chain. Check the sprocket for worn teeth, and replace if they are worn.

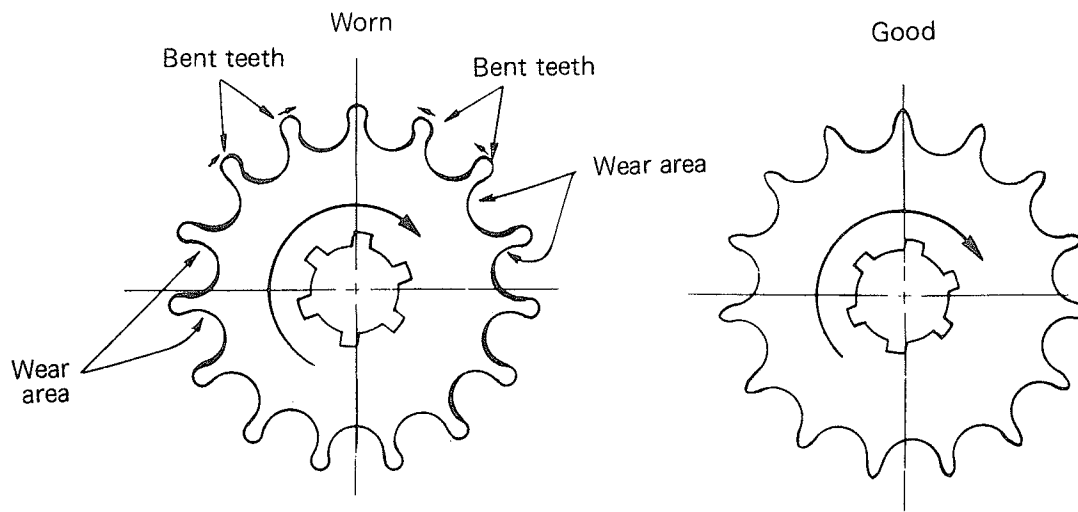

4-13 Crankcase

A. Separating

- 1) Remove neutral stopper and detent spring.

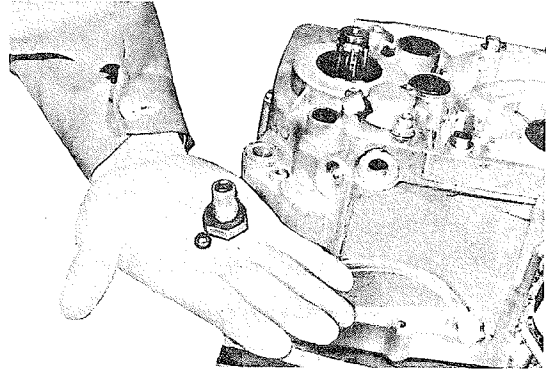
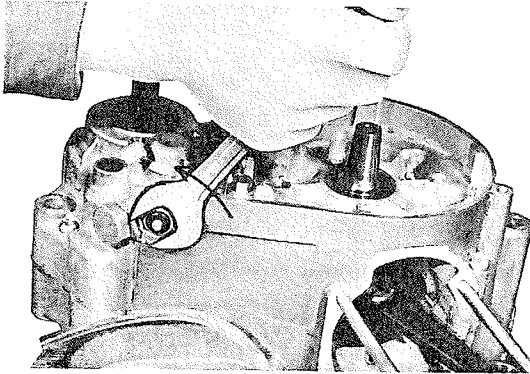

- 2) Remove the change shift drum stopper lever and stopper spring.

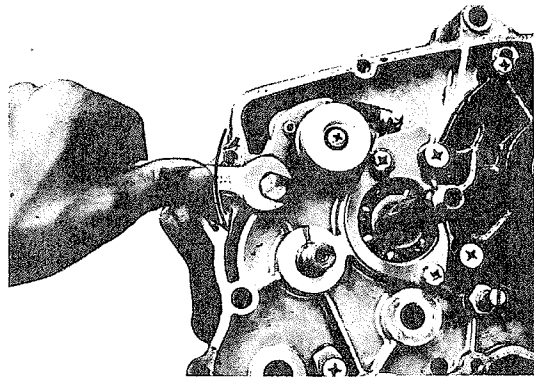

- 3) Remove the pan head screws from the left crankcase.

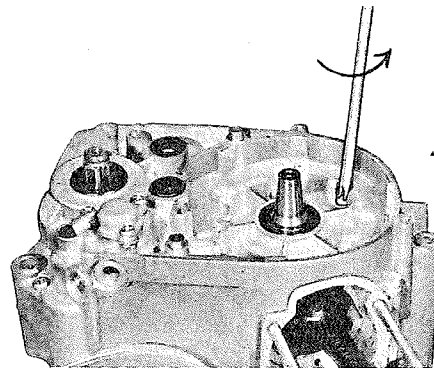

- 4) Install the crankcase separating tool on the right crankcase. Divide the crankcase while alternately tapping the main axle and the crankcase with a rubber tipped hammer.

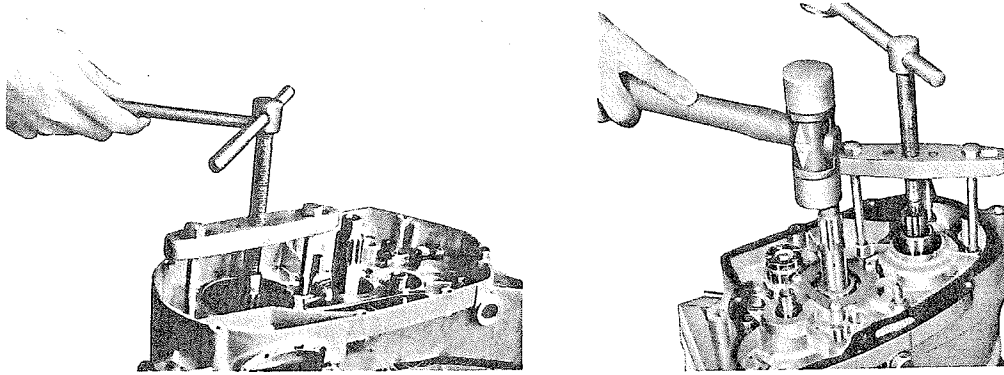

Note: Fully tighten the bolts of the crankcase dividing tool, keeping the tool in a horizontal position.

The crankcase is designed to split into two halves, right and left. Only one drain plug is provided for both the transmission and clutch housings. Both housings can be drained at the same time by removing the drain plug.

B. Reassembling

When reassembling the crankcase, be sure to apply YAMAHA BOND No. 4 to the mating surfaces of both halves after cleaning them thoroughly.

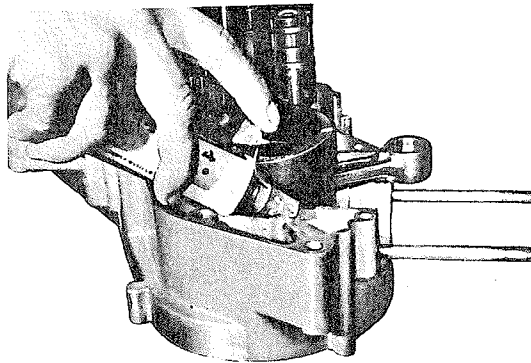

4-14 Transmission Assembly

The constant mesh, wide ratio, 5-speed transmission makes it possible to fully utilize the steady performance of the engine throughout the entire speed range from low to high.

For layout of the transmission and related parts see following pages.

The total reduction ratios will be; Primary reduction ratio x Transmission gear reduction x Secondary reduction ratio=Total reduction ratio.

Primary Reduction Ratio 74/19=3.895				
Secondary Reduction Ratio 45/14=3.214 (AT1-C) 49/14=3.500 (LT2, LT3)				
	Transmission Gear Reduction Ratio		Total Reduction Ratio	
	AT1-C	LT2, LT3	AT1-C	LT2, LT3
1st	35/11=3.182	35/11=3.182	39.832	43.373
2nd	30/15=2.000	30/15=2.000	25.037	27.263
3rd	26/19=1.368	26/19=1.368	17.130	18.653
4th	23/23=1.000	23/23=1.000	12.518	13.631
5th	20/25=0.800	20/25=0.800	10.015	10.905

Primary Reduction Ratio 74/19=3.895			
Secondary Reduction Ratio . . . 45/15=3.000(AT2,AT3), 45/16=2.813(CT1-C,CT2,CT3)			
	Transmission Gear Reduction Ratio	Total Reduction Ratio	
		AT2, CT3	CT1-C, CT2, CT3
1st	35/11=3.182	39.832	34.865
2nd	30/15=2.000	25.037	21.914
3rd	26/19=1.368	17.130	14.989
4th	23/23=1.000	12.518	10.957
5th	20/25=0.800	10.015	8.766

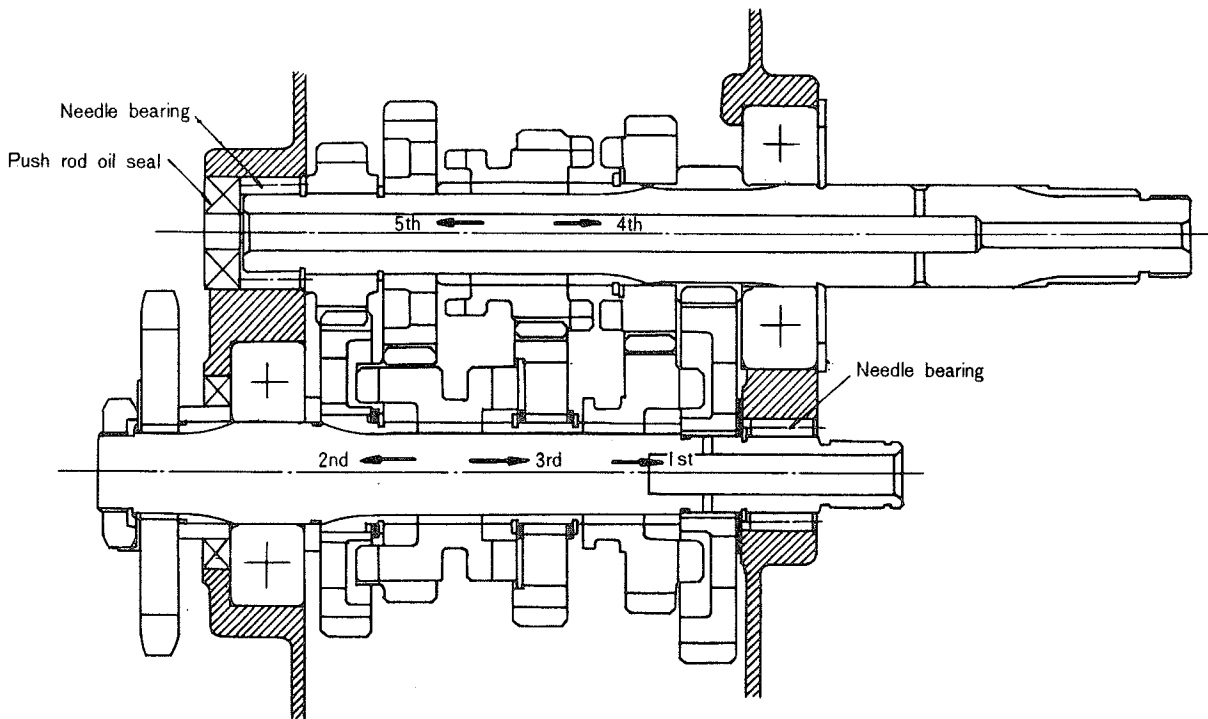

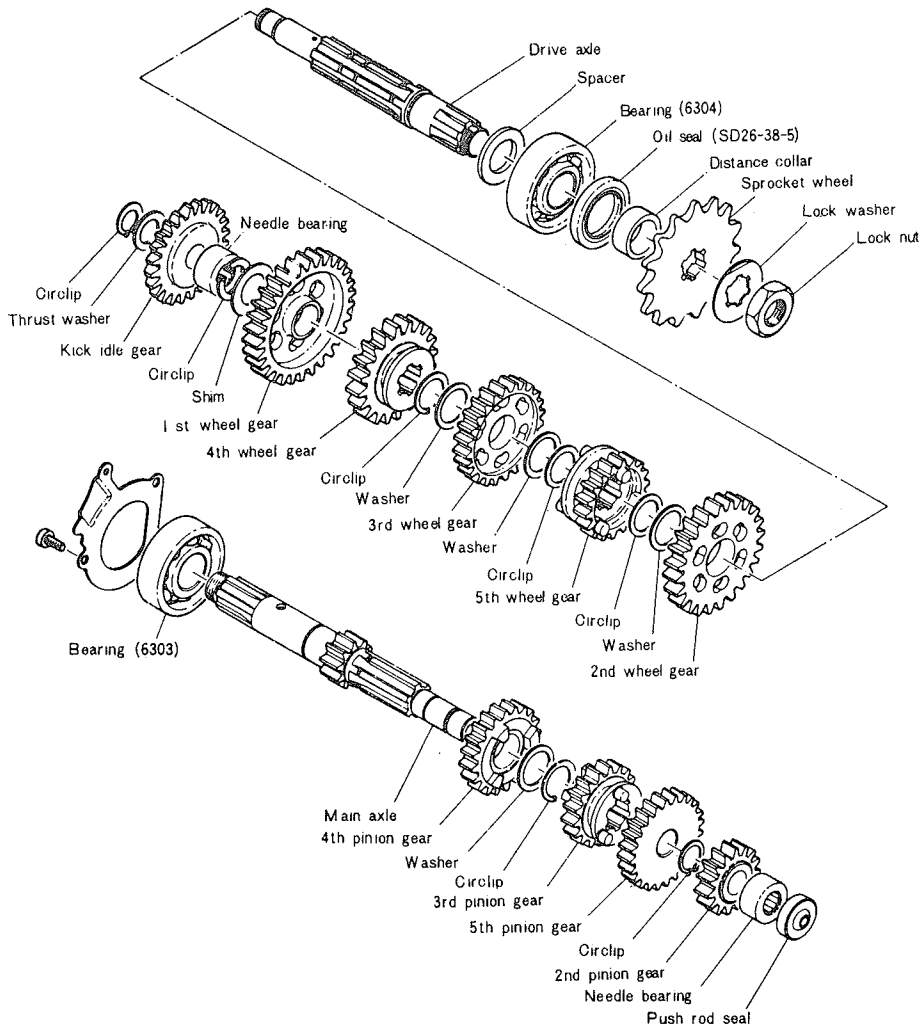

A. Removal

- 1) Pull out the two shift fork guide bars.

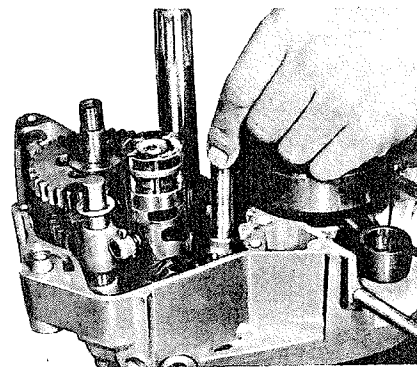

- 2) Remove both the transmission assembly and the shift forks from the crankcase, while tapping the drive shaft end with a plastic-tip hammer.

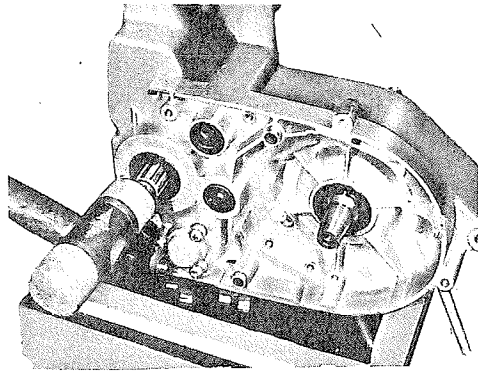

- 3) To remove the shift drum, remove the shift cam blind plug set screw on the left side of the crankcase, and remove the shift cam blind plug. Then remove the Clip and washer from the shift drum, and the shift drum can be pulled out from the opposite side.

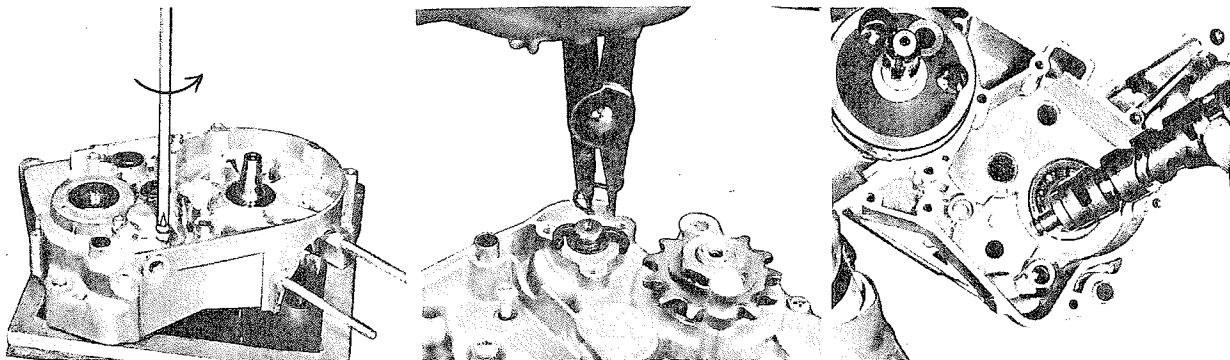

B. Reinstallation

Reinstall the transmission and shifter as a unit in the left crankcase half after they are sub-assembled. They cannot be installed separately. The transmission unit must be in neutral during installation.

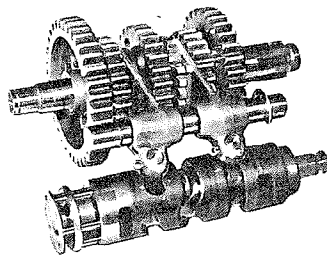

4-15 Crankshaft

The crankshaft requires the highest degree of accuracy in engineering and servicing of all the engine parts.

The crankshaft is also more susceptible to wear, and therefore, it must be handled with special care.

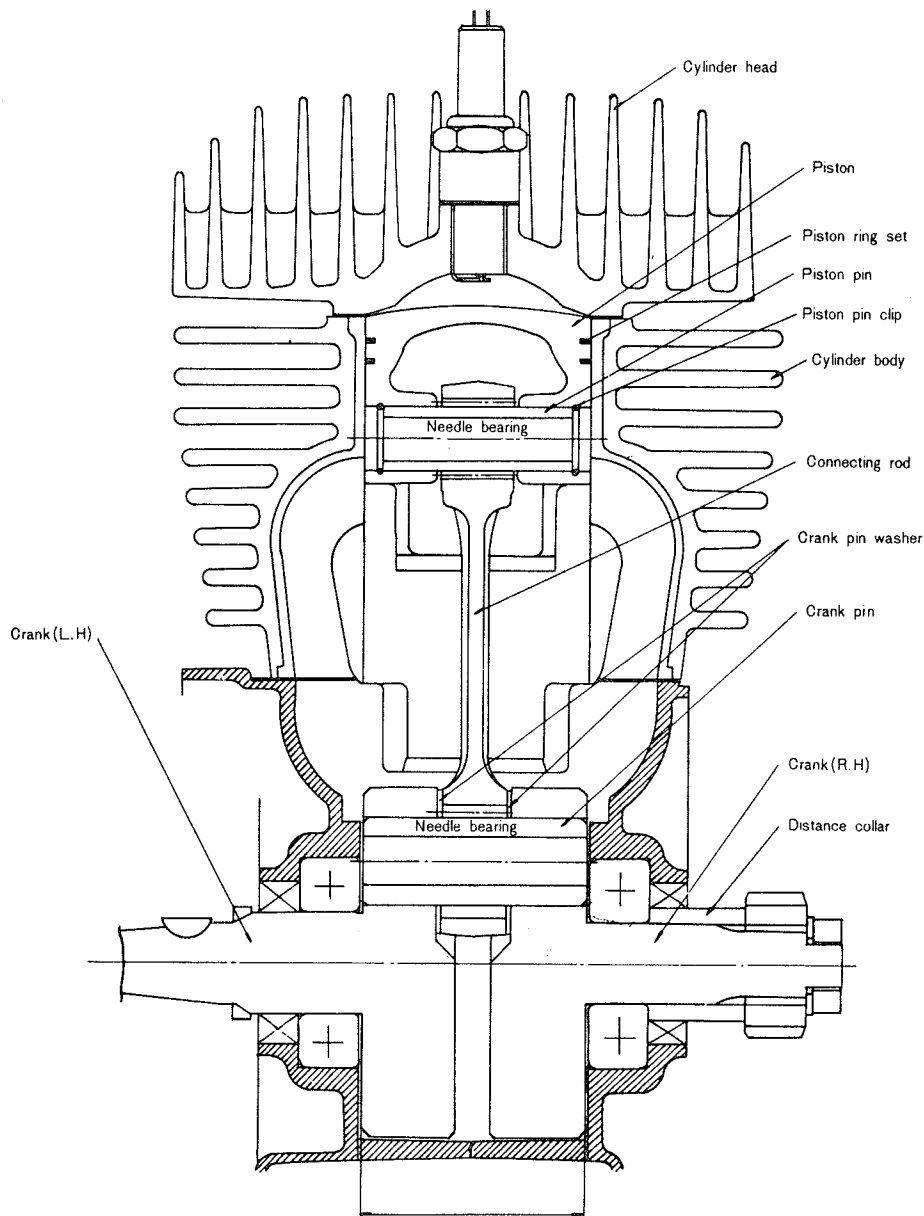

LT series	50 mm
AT, CT series	56 mm

Crankshaft component parts

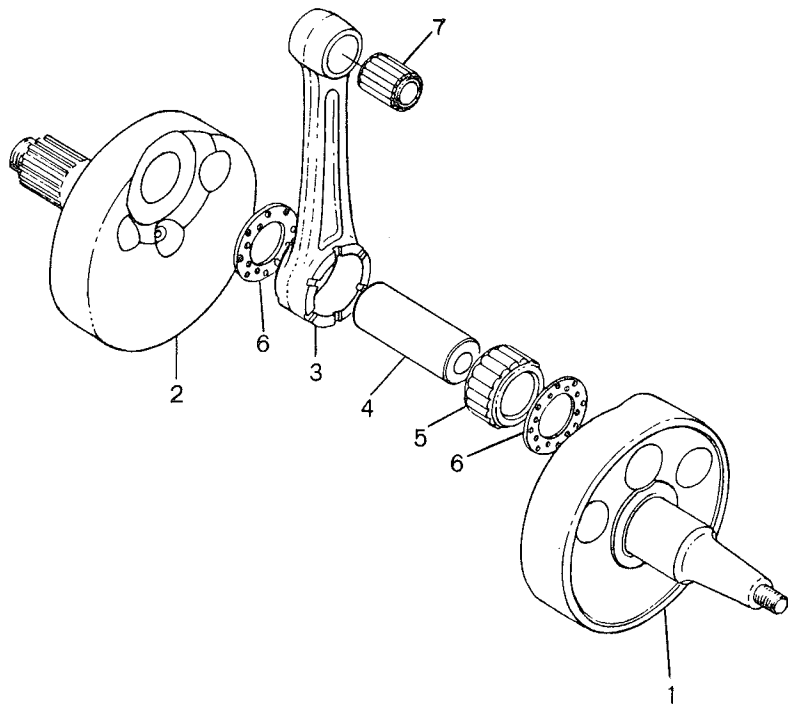

1. Crank (L.H.)
2. Crank (R.H.)
3. Connecting rod
4. Crank pin
5. Bearing
6. Crank pin washer
7. Bearing

A. Removing the Crankshaft Assembly

Remove the crankshaft assembly with the crankcase separating tool.

Note: Fully tighten the bolts of the crankcase dividing tool, and keep the tool parallel with the crankcase surface.

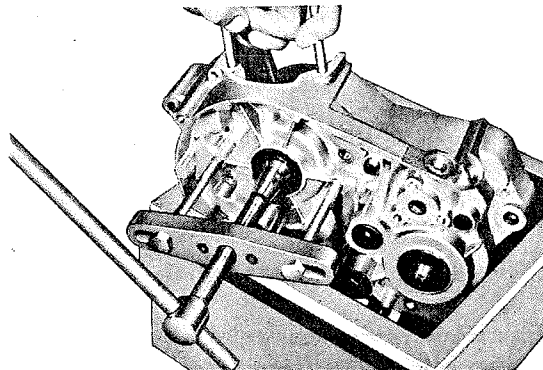

B. Installing the Crankshaft Assembly

Install the crankshaft assembly by using the crankshaft setting tool.

Hold the connecting rod at top dead center with one hand while turning the handle of the setting tool with the other.

2) Reinstalling the Crankshaft Ass'y

Put shims on both ends of the crankshaft, and install the crankshaft assembly by using the crankshaft installing tool.

Hold the connecting rod at top dead center with one hand while turning the handle of the installing tool with the other.

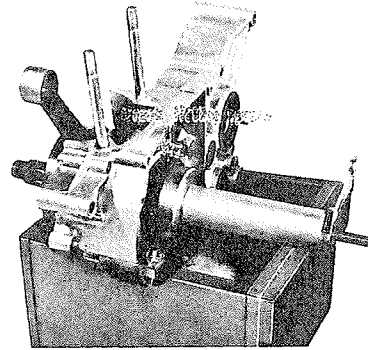

C. Inspection and Servicing

1) Checking the crankshaft components

<p>Check connecting rod axial play at small end (to determine the amount of wear of crank pin and bearing at large end)</p>	<p>Small end play should not exceed 2 mm. (0.078 in.)</p>	<p>If small end play exceeds 2 mm, disassemble the crankshaft, check connecting rod crank pin and large end bearing. Replace defective parts. Small end play after reassembly should be within 0.8-1.0 mm. (0.031~0.04 in.)</p>
<p>Check the connecting rod for axial play at large end.</p>	<p>Move the connecting rod to one side and insert a feeler gauge. Large end axial play should be within 0.4-0.5 mm. (0.019 in.)</p>	<p>If excessive axial play is present, (0.6 mm or more) disassemble the crankshaft and replace any worn parts.</p>
<p>Check accuracy of the crankshaft ass'y runout. (Misalignment of parts of the crankshaft)</p>	<p>Dial gauge readings should be within 0.03 mm. (0.0012 in.)</p>	<p>Correct any misalignment by tapping the flywheel with a brass hammer and by using a wedge.</p>

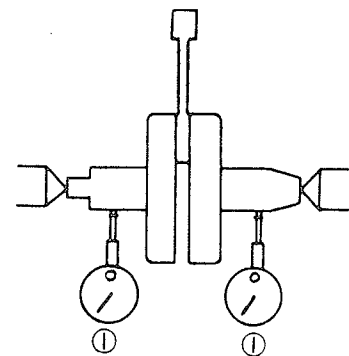
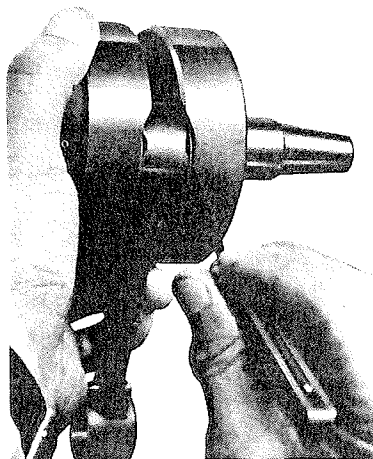
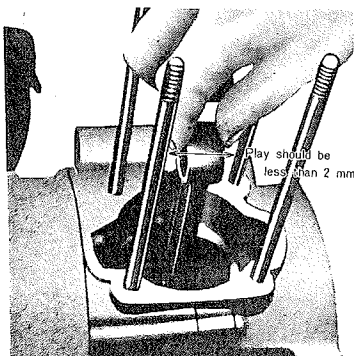

4-16 Bearings and Oil Seals

LT series

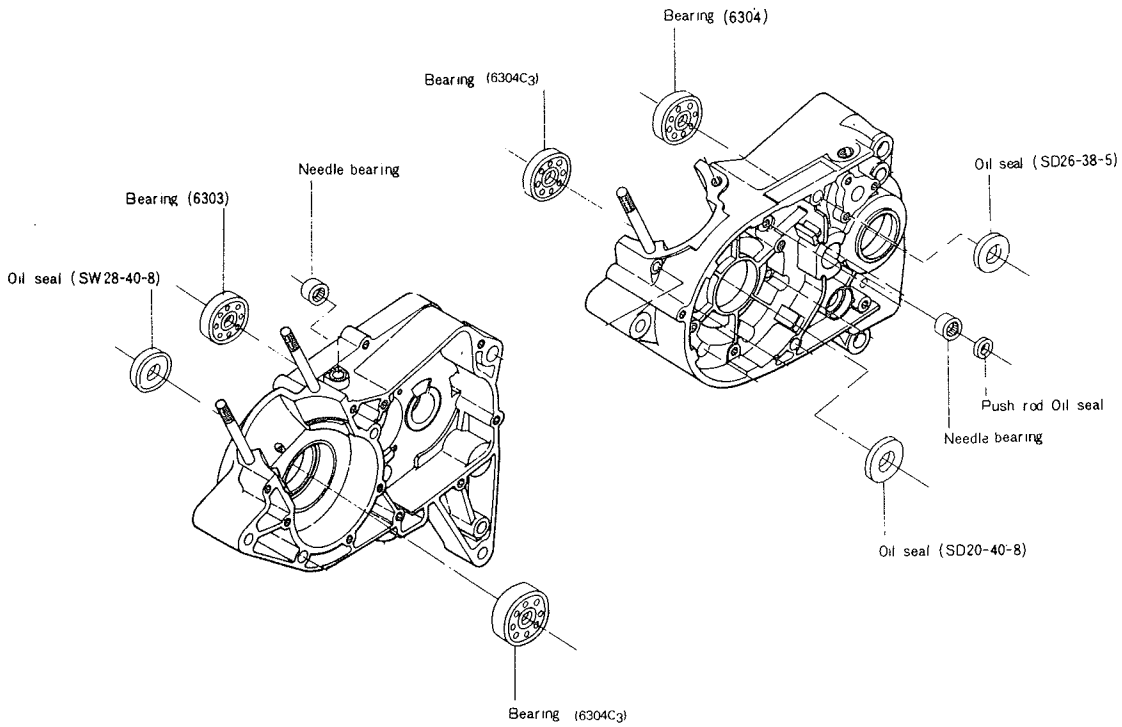

AT, CT series

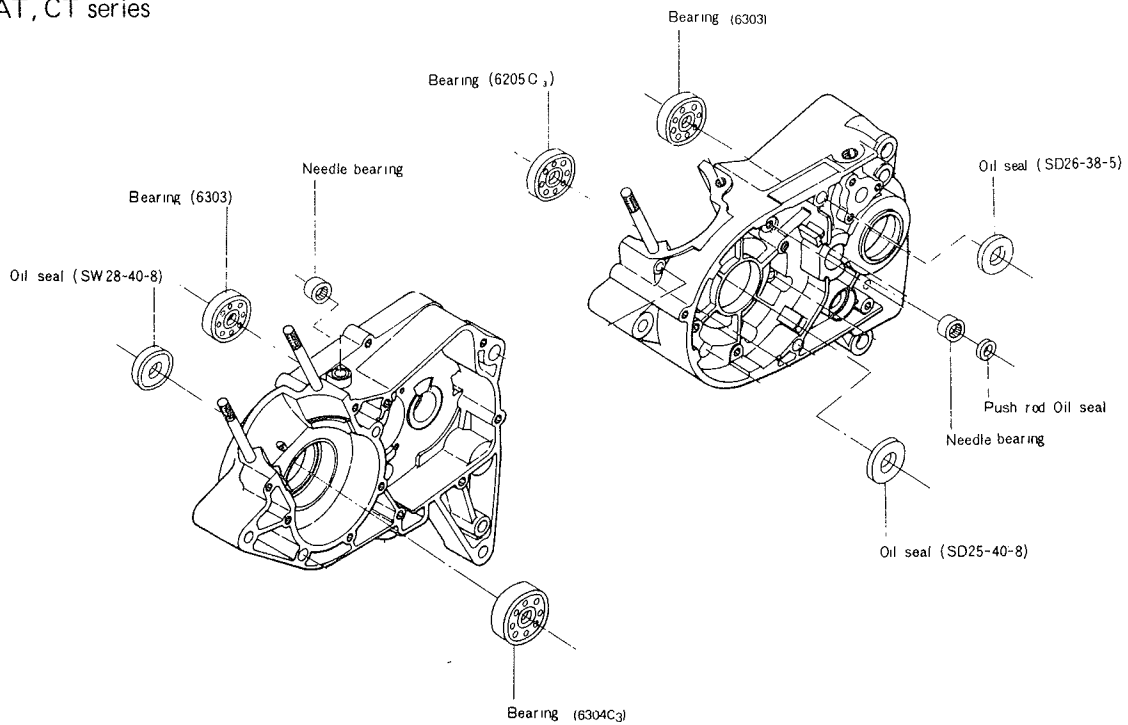

1. Removal and Installation

1) Removal

- a. Pry the oil seals out of place with a slot head screwdriver.

Always replace the oil seals when overhauling the engine.

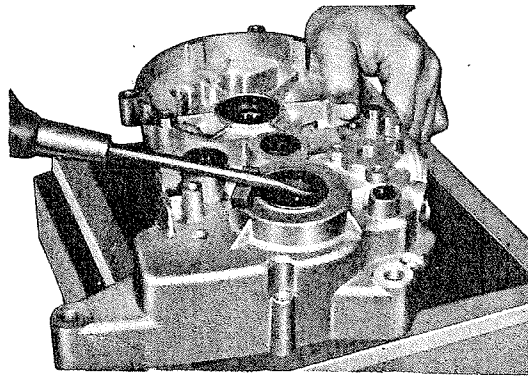

- b. Drive out the bearing with a bearing tool.

Note: Bearings are most easily removed or installed if the cases are first heated to approximately 200° - 400°F. However, cold removal and installation can often times be done satisfactorily.

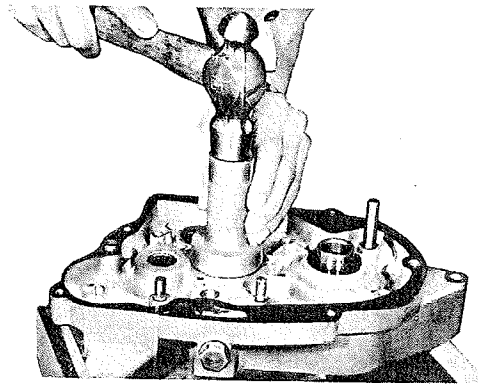

2) Installation

Install bearings and oil seals with their stamped manufacturer's marks or numerals facing outward. (In other words, the stamped letters must be on the exposed view side.)

When installing bearings, pack them with grease.

4-16 Bearings and Oil Seals

The standard AT, CT series are equipped with a VM24SH(C)(24 mm.) and LT series are VM20SH(C)(20mm) carburetor that is equip with a built-in starter jet.

The carburetor is bolted to a insulator that is located between the carburetor and reed valve ass'y. This insulator provides more than adequate heat insulation. The carburetor floats have been specially designed to keep the float level from fluctuating due to vibration or shock. The main jet is installed in such a manner to provide quick and easy replacement from the outside by merely removing the jet holder on the bottom left side of the carburetor float bowl.

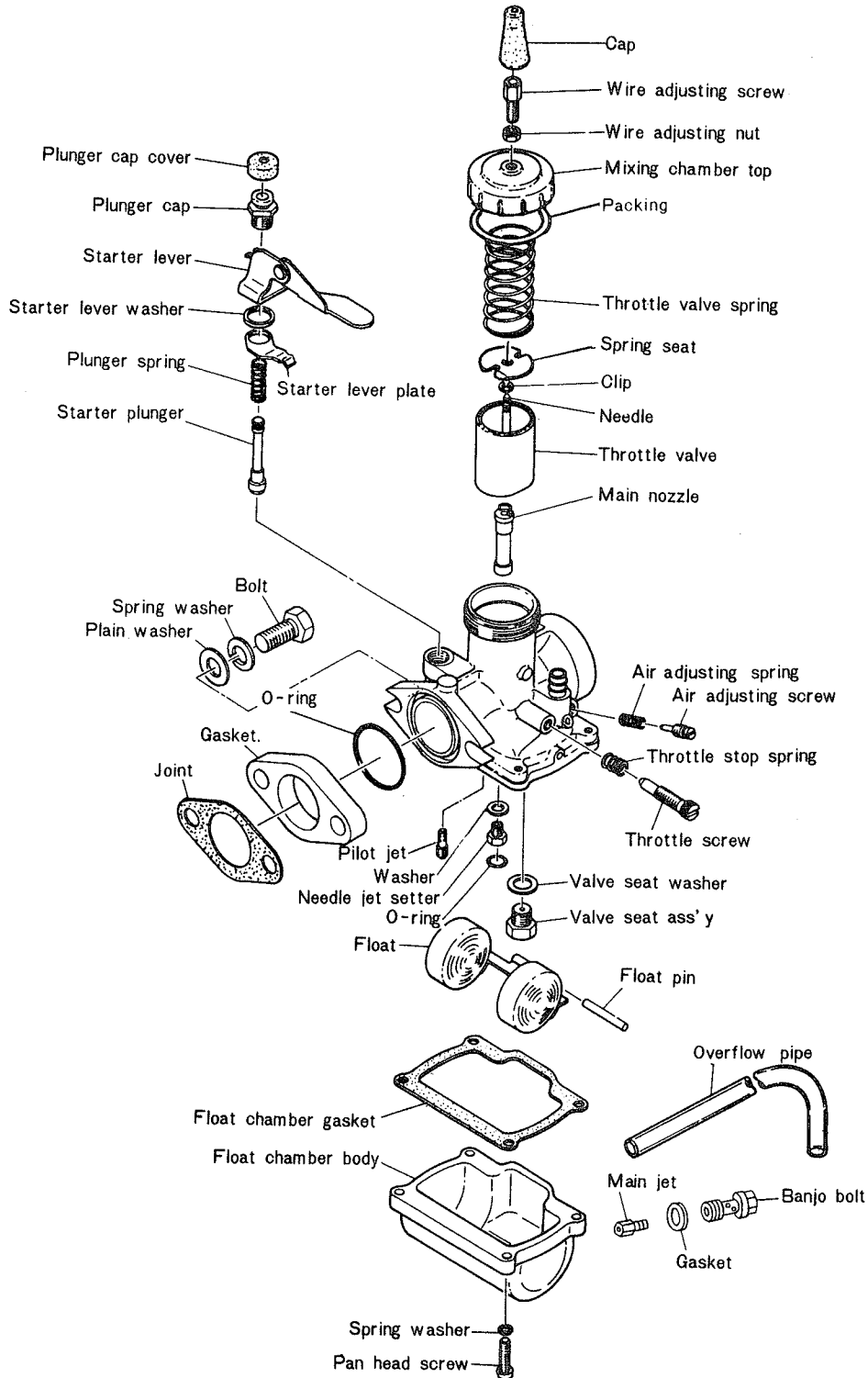

A. Checking the Carburetor

1) Float

Remove the float and shake it to check if gasoline is inside. If fuel leaks into the float while the engine is running, the float chamber fuel level will rise and make the fuel mixture too rich. Replace the float if it is deformed or leaking.

2) Float valve

Replace the float valve if its seating end is worn with a step or if it is scratched. Check the float valve spring for fatigue. Depress the float valve with your finger, and make sure that it properly seats against the valve seat. If the float valve spring is weakened, fuel will overflow flooding the float chamber while the gas is on.

3) Overflowing

If fuel overflows, check the carburetor as described in 1) and 2) above. If neither 1) nor 2) cures the overflowing, it may be caused by dirt or dust in the fuel preventing the float valve from seating properly. If any dirt or dust is found, clean the carburetor, petcock and gas tank.

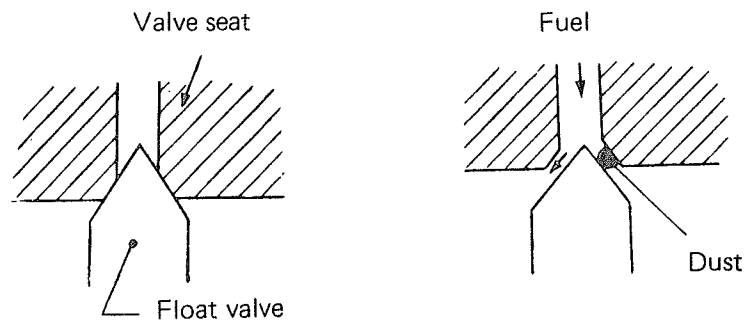

4) Cleaning the carburetor

Disassemble the carburetor, and wash all its parts in a suitable solvent.

Then blow all the parts off with compressed air. All jets and other delicate parts should be cleaned by blowing compressed air through them after the float bowl has been removed.

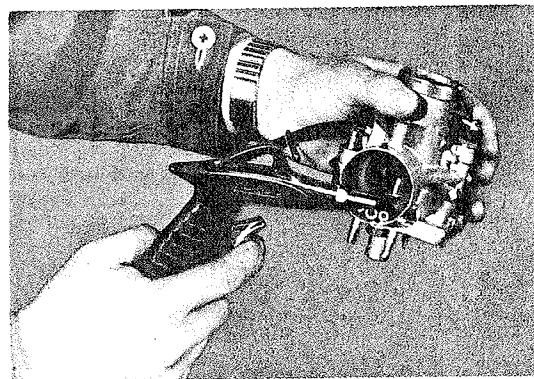

B. Float Level Adjustment

The carburetor float level is checked by the Yamaha factory during assembly and testing. But rough riding, worn needle valve, or bent float arm can cause the float level to fluctuate. If the float level raises, this will cause a rich fuel/air mixture that can cause poor performance and spark plug fouling. If the float level decreases, this can cause a lean fuel/air mixture that can result in engine damage. If the machine is subjected to continuous rough riding or many miles of travel, the float level should be checked and set regularly and in the following manner.

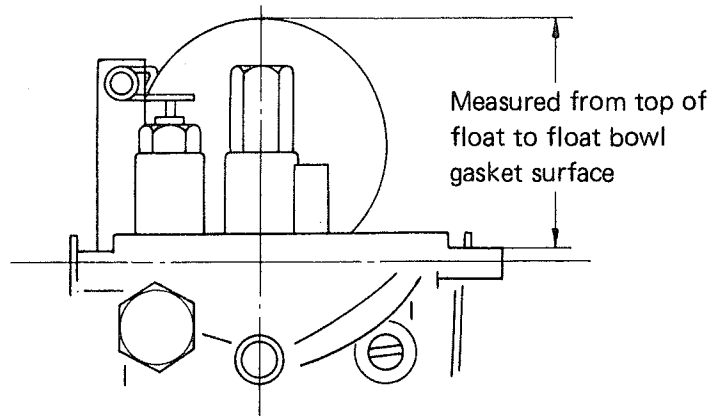

- 1) Remove the float chamber body, and turn over the mixing body. Let the float arm rest on the needle valve without compressing the spring.
- 2) Then measure the distance from the top of the float to the float bowl gasket surface.

*Float Level Table

Model	Carb I.D. No.	Float distance (mm)
AT1-C	248A2	25.75 ± 2.5 mm
CT1-C	248A2	25.75 ± 2.5 mm
LT2	305E2	21.0 ± 2.5 mm
LT3	305E2	21.0 ± 2.5 mm
AT2	316E2	21.0 ± 2.5 mm
AT3	316E2	21.0 ± 2.5 mm
CT2	314E1	21.0 ± 2.5 mm
CT3	314E1	21.0 ± 2.5 mm

- 3) When the distance measures less than the recommended distance, bend the tang up. If it is greater, bend the tang down. (with carburetor body upside down.)

D. Carburetor Setting Table

Name of Parts	Abbreviation	Specifications				
		AT1-C	CT1-C	LT2, LT3	AT2,AT3	CT2, CT3
Main jet	N.J	#150	#150	#130	#230	#230
Needle jet	N.J	N – 8	N – 8	N – 6	O – 6	O – 6
Jet needle	J.N	4D3-3 stages	4D3-3 stages	4J13-2	5J3-3 stages	4J13-2stages
Pilot jet	P.J	#30	#30	#25	#35	#25
Starter jet	G.S	#40	#40	#30	#40	#40
Throttle valve-cut away	C.A	2.0	2.0	1.5	2.5	2.0
Air screw setting	A.S	1½	1½	1½	2.0	2.0
Idling speed	—	1200-1300 rpm	1200-1300 rpm	1350-1450 rpm	1300-1400 rpm	1300-1400 rpm
Ident. Mark	—	248A2	248A2	305E2	316E2	314E1

4-18 Air Cleaner

A. Removal

To remove the air filter, first remove two oil tank fitting bolts. Next, remove the air cleaner case cap fitting spring and air cleaner case cap. Then the element can be removed.

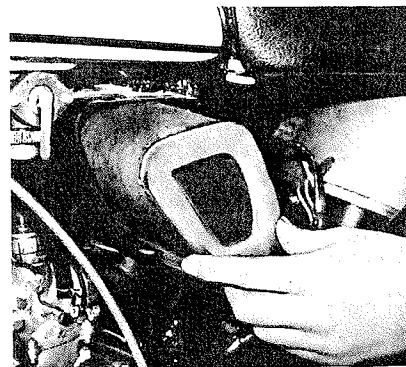
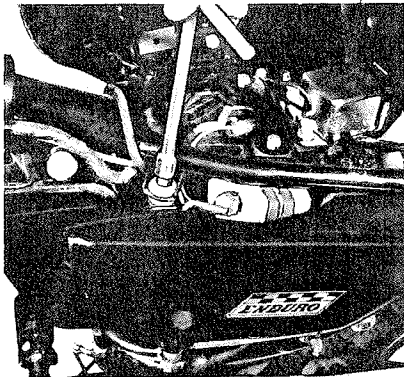

B. Cleaning

Wash the foam filter, thoroughly in solvent until all dirt has been removed. Squeeze all the solvent out. Pour oil onto the filter (any grade of 20 or 30 wt), work it completely in, and then squeeze out the surplus oil. The filter should be completely impregnated with oil, but not "dripping" with it.

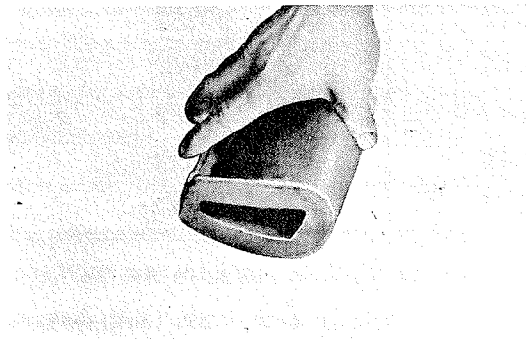

CHAPTER 5. CHASSIS

The Yamaha's have been designed for versatility. They are equipped with all necessary street legal equipment to insure pleasurable road or street riding. This machine can be quickly converted to a competition machine and therefore have been engineered to have a minimum weight factor. Yet with the reduction in weight; rigidity; strength, and safety have been incorporated in the design of the frame to provide an unexcelled competition machine.

5-1 Front Wheel

The 18" front wheel is equipped standard with a 3.00-18" (AT series) and 3.25-18" (CT series) Trials Universal tire.

Note: LT2/LT3 have 2.75-18" tire

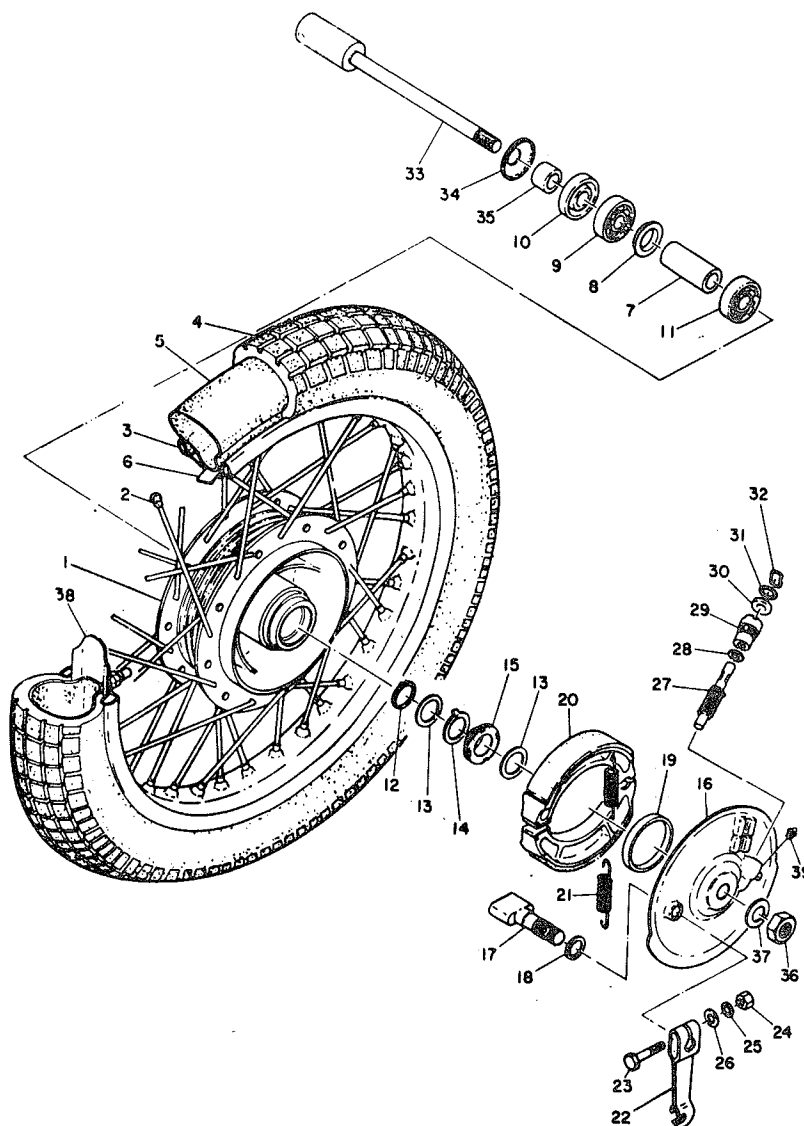

Construction

1. Hub
2. Spoke set
3. Rim
4. Front tire
5. Tube
6. Rim band
7. Bearing spacer
8. Spacer flange (AT, CT series)
9. Bearing (6301Z)
10. Oil seal (SD18-37-8)
11. Bearing (6301Z)
12. Circlip
13. Thrust washer 2
14. Meter clutch
15. Drive gear
16. Brake shoe plate
17. Shaft cam
18. Cam shaft shim
19. Oil seal (SDD47-58-7)
20. Brake shoe complete
- 21q Brake shoe return spring
22. Cam shaft lever
23. Bolt
24. Nut
25. Spring washer
26. Plain washer
27. Meter gear
28. Thrust washer 1
29. Bushing
30. Oil seal SO7-14-4 (LT series)
SO7-14-7 (AT, CT series)
31. O ring 2.4 - 13.8
32. Stop ring
33. Wheel shaft
34. Hub dust cover
35. Wheel shaft collar
36. Shaft nut
37. Spring washer
38. Bead spacer
39. Grease nipple

CHASSIS – Front Wheel

This tire gives the rider assurance of maximum performance and safety for both road riding and trail riding. A labyrinth seal is installed between the wheel hub and brake plate to provide a seal against dust and water.

A. Removal

- 1) Disconnect the brake cable at the front brake lever.

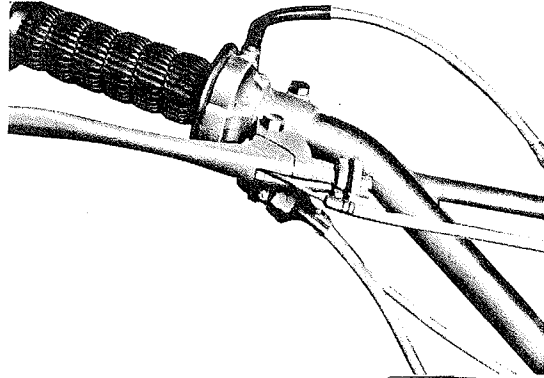

- 2) Disconnect the speedometer cable from the front wheel hub plate.

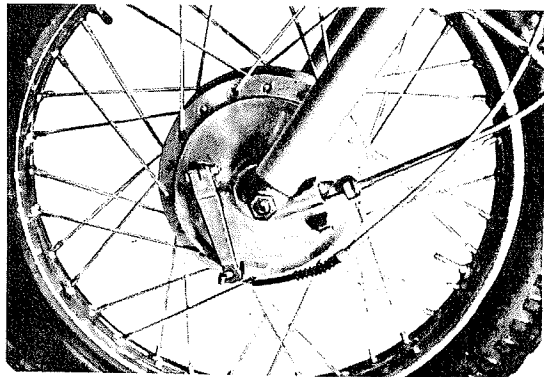

- 3) Loosen the front wheel axle pinch bolt.

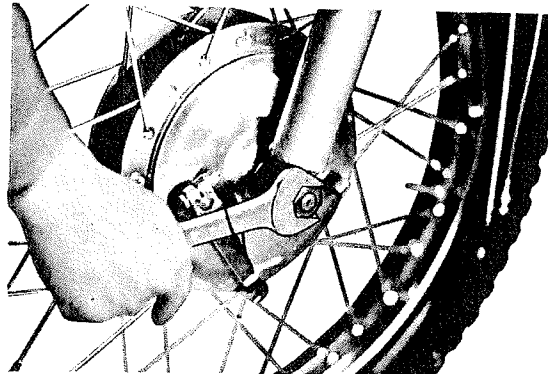

4) Remove the front wheel nut.

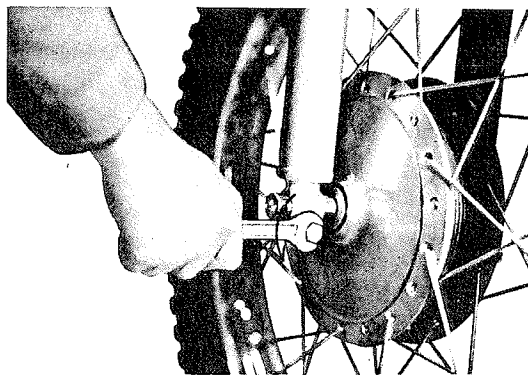

5) Remove the front wheel axle by simultaneously twisting and pulling out on the axle.

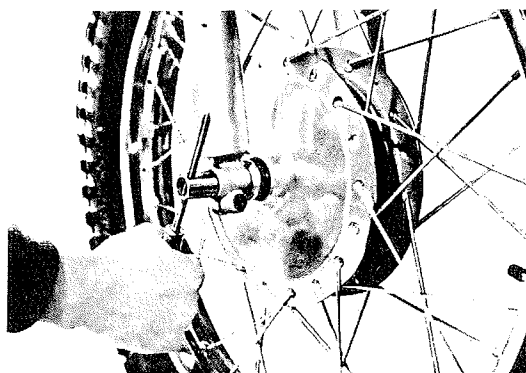

6) Raise the front of the machine and set it on a box. Then remove the wheel assembly.

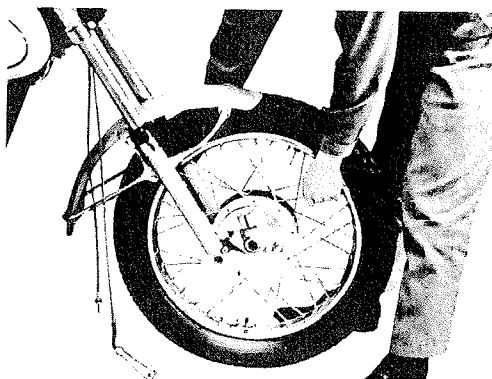

B. Checking

1) Run out of the rim

Measure the runout of the rim with a dial gauge. Run out limits : 2 mm. (0.07 in.) or less.

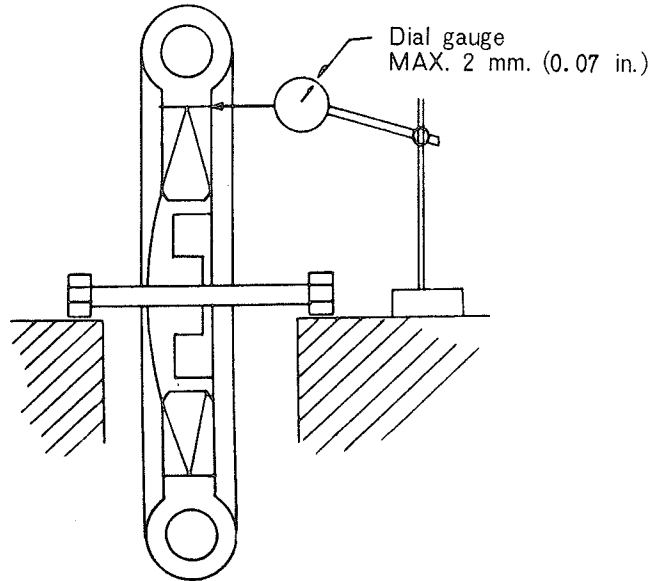

2) Brake shoe

	LT2	LT3	AT1-C	AT2	AT3	CT1-C	CT2	CT3
Front brake dimensions	108mm	108mm	108mm	108mm	108mm	108mm	108mm	108mm
Replacement limits	104mm	104mm	104mm	104mm	104mm	104mm	104mm	104mm

Measure the outside diameter at the brake shoe with slide calipers. If it measures less than above list, replace it.

Smooth out a rough shoe surface with sandpaper or with a file.

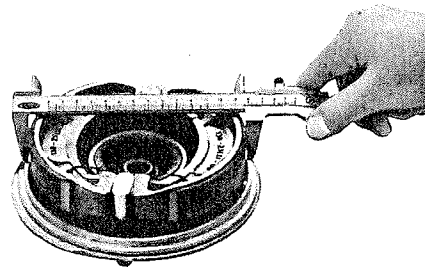

3) Brake drum

Oil or scratches on the inner surface of the brake drum will impair braking performance or result in abnormal noises. Remove oil by wiping with a rag soaked in lacquer thinner or solvent. Remove scratches by lightly and evenly rubbing with emery cloth.

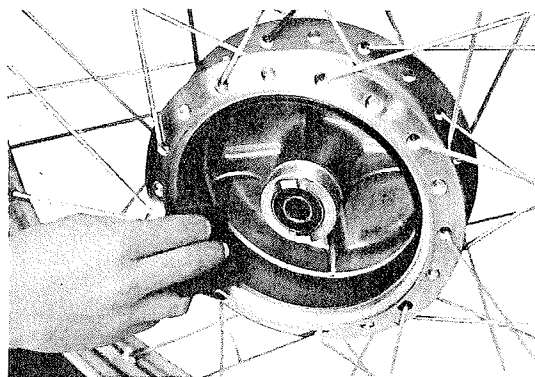

4) Check the spokes. If they are loose or bent, tighten or replace them. If the machine is ridden in rough country often, or raced, the spokes should be checked regularly.

5) Repairing the brake shoe

If the brake shoe has uneven contact with the brake drum, or is scratched, smooth out the surface with sandpaper or hand file.

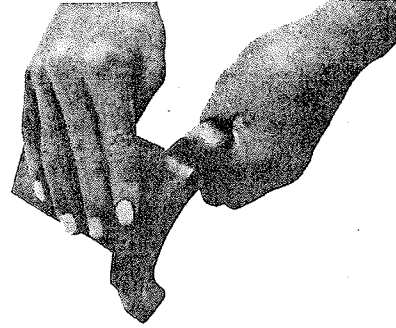

6) If the tire is excessively worn, replace it.

7) Regularly check the tires for damage.

8) If the bearings allow excessive play in the wheel or if it does not turn smoothly, replace the bearing.

9) Replace a bent or damaged front wheel axle.

10) If the tooth surface of the helical speedometer drive gear is excessively worn, replace it.

11) Check the lips of the seals for damage or warpage. Replace if necessary.

Replacing the Wheel Bearing

- a. First clean the outside of the wheel hub.
- b. Insert the bent end of the special tool into the hole located in the center of the bearing spacer, and drive the spacer out from the hub by tapping the other end of the special tool with a hammer. (Both bearing spacer and space flange can easily be removed.)
- c. Then push out the bearing on the other side.
- d. To install the wheel bearing, reverse the above sequence. Be sure to grease the bearing before installation and use the bearing fitting tool (furnished by Yamaha).

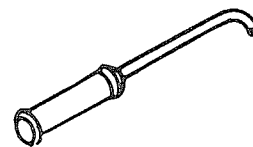
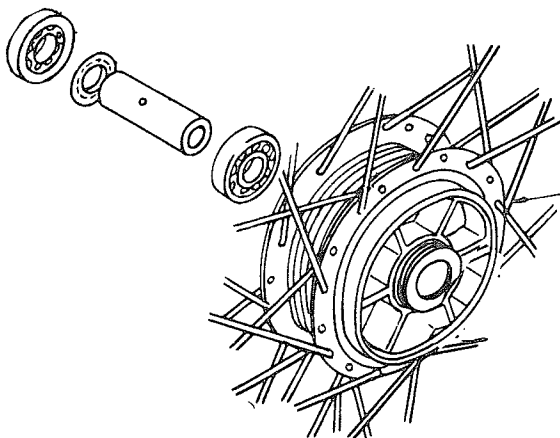

Insert the bent end of the special tool into the hole located in the center of the bearing spacer.

CHASSIS – Rear Wheel

5-2 Rear Wheel

The rear wheel is 18-in. size, and the rear tire is Trials Universal. Single leading shoe type brake is used. A labyrinth seal between the wheel hub and the brake plate is provided to prevent water and dust leakage. The brake tension bar is of link design to minimize the shifting of the brake cam lever position when the rear swing arm is moving up and down. The rear fender is steel, and rubber mounted on the frame. It is also wide enough to protect the engine unit from dust and water.

Tire size— LT series: 3.00-18

AT series: 3.25-18

CT series: 3.50-18

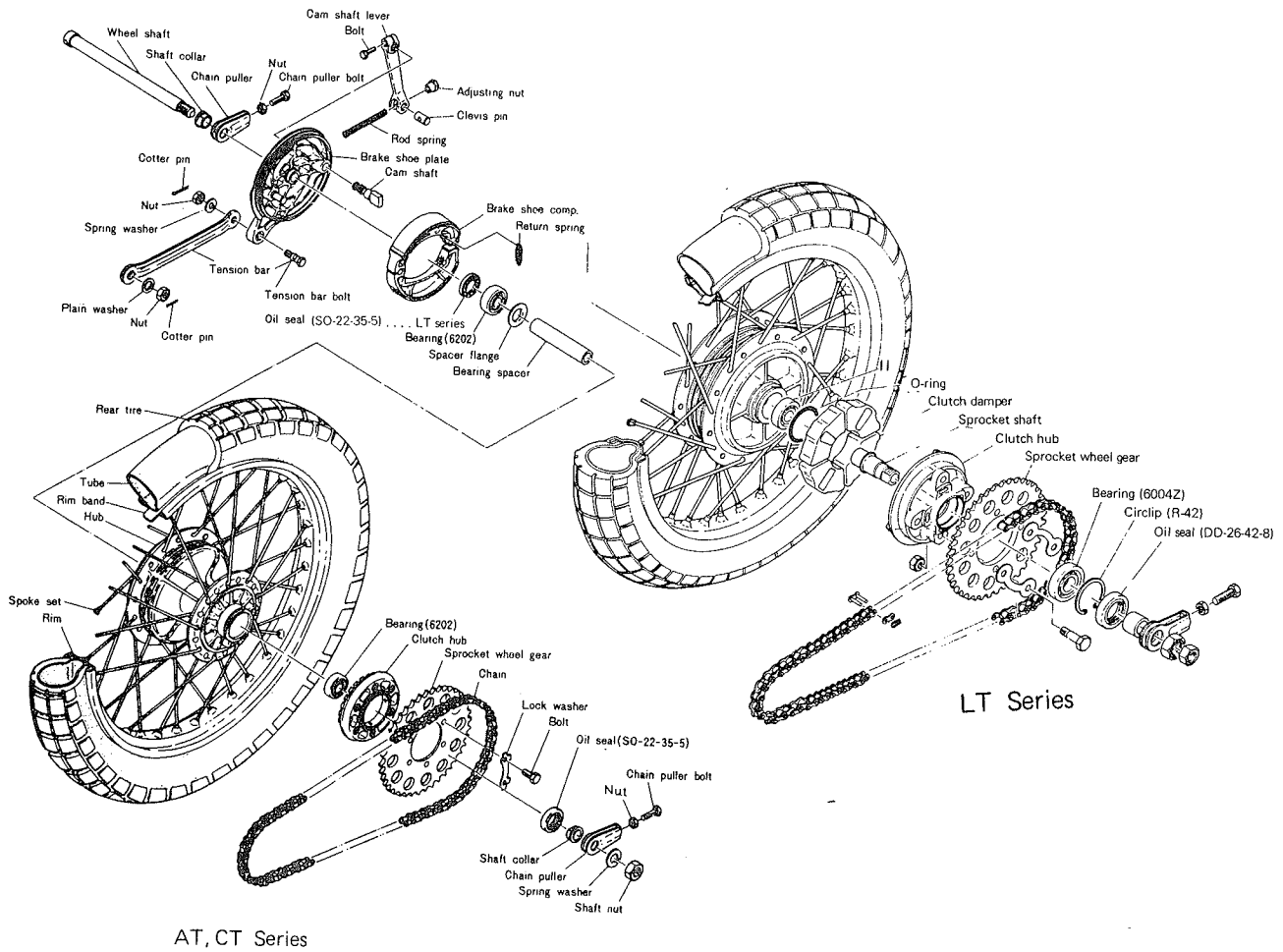

AT, CT Series

LT Series

Rear Wheel Construction

A. Removal

- 1) Remove the tension bar and brake rod from the rear shoe plate.

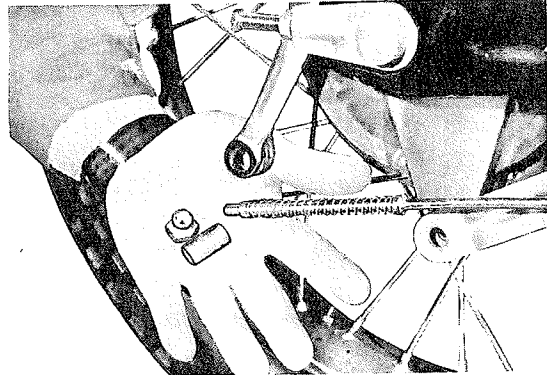
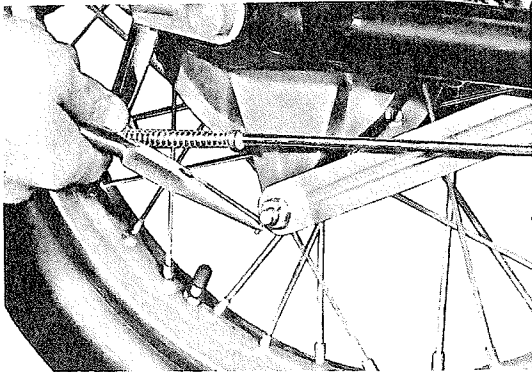

- 2) Loosen the chain tension adjusting nuts and bolts on both right and left sides.

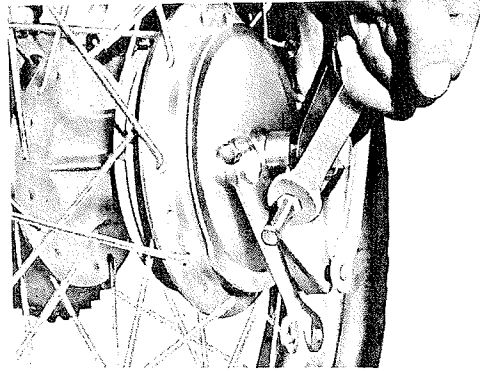

- 3) Remove the rear wheel shaft nut.

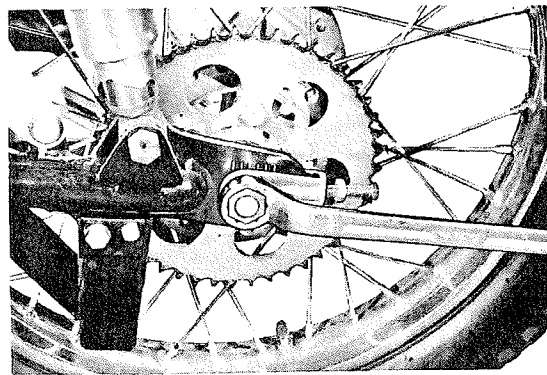

CHASSIS – Rear Wheel

- 4) Pull out the rear wheel shaft by striking it with a plastic tip hammer.

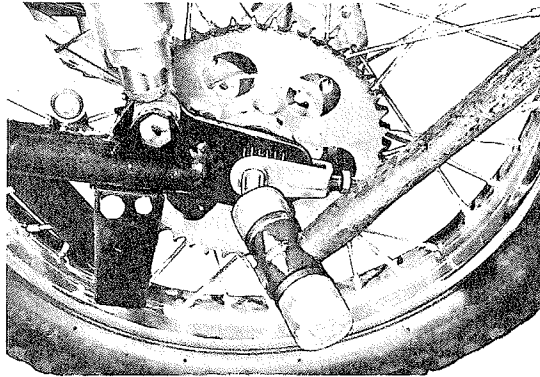

- 5) Remove the right-hand chain adjuster and distance collar.

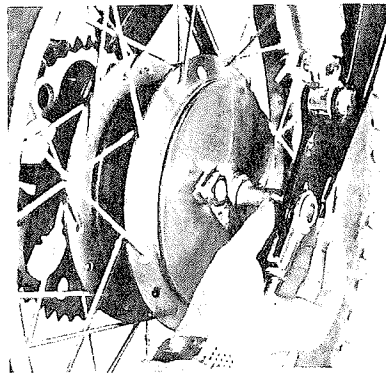

- 6) Remove the rear brake shoe plate.

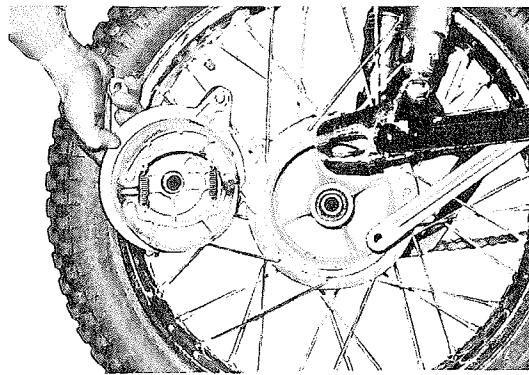
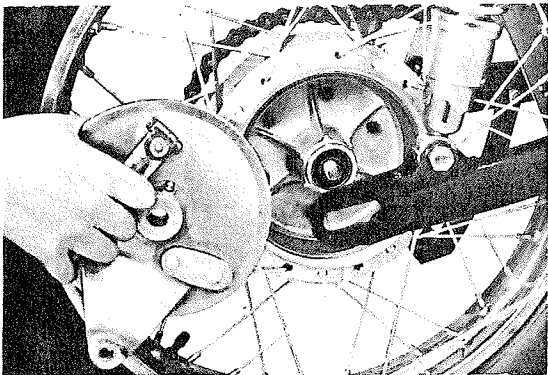

- 7) Lean the machine to the left and remove the rear wheel assembly.

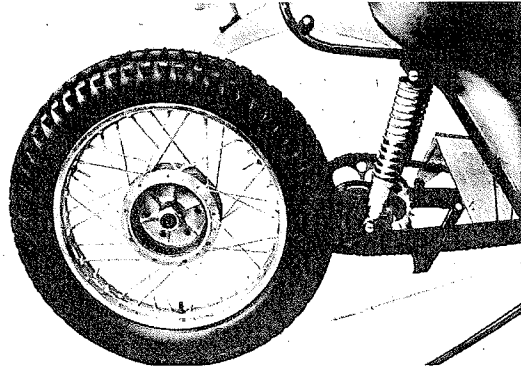

Replacing the Wheel Bearing

Replace the wheel bearing in the same way as the front wheel bearing.

Replacing Tires

1) Removal

- a. Remove the valve cap and lock nut (12 mm.) from the tire valve, and deflate the tire.
- b. Remove the tire from the wheel rim by the use of two tire levers. (Exercise care to avoid damaging the inner tube with the levers.)

It is noted that to remove the inner tube, one side of the tire should be pried out of the wheel rim.

2) Installation

- a. Insert the tube between the tire and the wheel rim, and inflate the tube to remove creases. Be sure that the valve stem is directed toward the wheel shaft. At this time the tire is still halfway off the rim.

CHASSIS – Rear Wheel

- b. Force the tire completely back on the wheel rim by the use of tire levers. For this operation, it is advisable that the bead on the other side of the tire be pushed in toward the rim flange.
- c. To avoid pinching the tube between the tire and the rim, tap the tire with a hammer as the tire is partially inflated.
- d. Tighten the tub valve lock nut, and inflate the tire to the recommended pressure, then install the valve cap.

B. Inspection

1) Run out of the rim

Check the rim for run out in the same way as the front wheel. Maximum limit of run out 2 mm. (0.07 in.) or less.

2) Brake shoe

Rear brake shoe

Measurement & replacement methods are identical to Front brake is tructions.

	LT2	LT3	AT1-C	AT2	AT3	CT1-C	CT2	CT3
Rear brake dimensions	128 mm	128 mm	128 mm	128 mm	128 mm	128 mm	128 mm	128 mm
Replacement limit	124 mm	124 mm	124 mm	124 mm	124 mm	124 mm	124 mm	124 mm

3) Brake drum

Check the brake drum in the same way as the front wheel.

- 4) The spokes are measured in the same way as the front wheel. A loose spoke should be tightened.
- 5) If the bearing has excessive play or it does not turn smoothly, replace it.
- 6) If the tire or the pattern is worn out, replace the tire.
- 7) If the lip of the oil seal is damaged or warped, replace it.

5-3 Rear Wheel Sprocket

A. Checking and Adjustment

The rear wheel sprocket is installed on the clutch hub. To replace the sprocket, take the following steps.

1) Removing the sprocket

- a. Bend the lock washer ears flat.

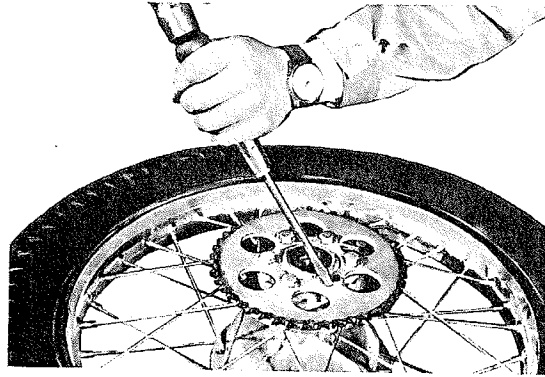

- b. Remove the sprocket mounting bolts.

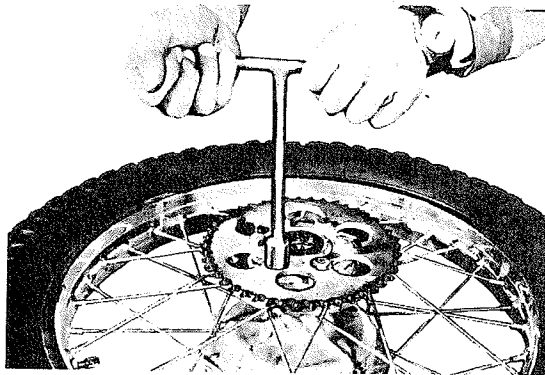

2) Checking

Check the lock washer and hexagonal bolt for breakage and damage. If the lock washer is not bent over the hexagonal bolt head, or is broken, or if the bolt is loose, the sprocket can come loose. Make sure that both lock washers and the mounting bolts are tight.

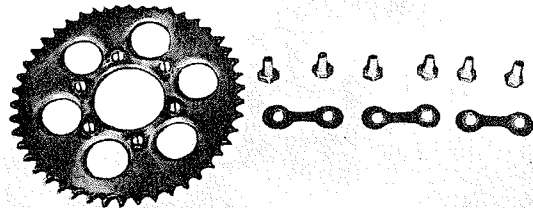

5-4 Tires and Tubes

1) Normal tire pressure

Though tire pressure is the rider's choice, the standard tire pressure is as follows.

a. On-the-road riding

Front 14 lbs./in². (1.0 kg./cm².)

Rear 17 lbs./in². (1.2 kg./cm².)

When the tire pressure is reduced below the specified value because of some reason, the tire may slip around the rim.

To prevent this slipping of the tire, bead stoppers should be used.

5-5 Front Forks

The LT, AT and CT series are equipped with competition designed telescopic double damping front forks. These specially designed front forks provide excellent riding comfort along with handling superiority.

The combination of fork stability and long stroke travel provides safety and handling ease for the rider over even the roughest terrain. This front fork design also reduces weight, eases maintenance, and gives functional and attractive appearance. The simplicity and dependability of the front forks is provided by the installation of the fork spring inside of the fork tube.

Maximum stroke	LT series	4.8 inches (120 mm)
----------------	-----------	---------------------

	AT, CT series	5.8 inches (145 mm)
--	---------------	---------------------

A. Removal

1) Remove the front fender

The light-weight aluminum front fender is rubber-mounted.

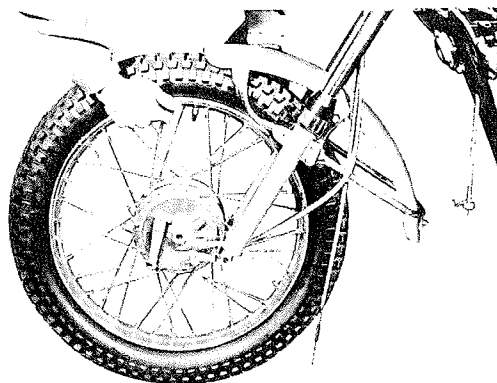

2) Remove the inner tube cap bolt.

You must loosen the arrow marked pinch bolt before the cap bolt is loosened.

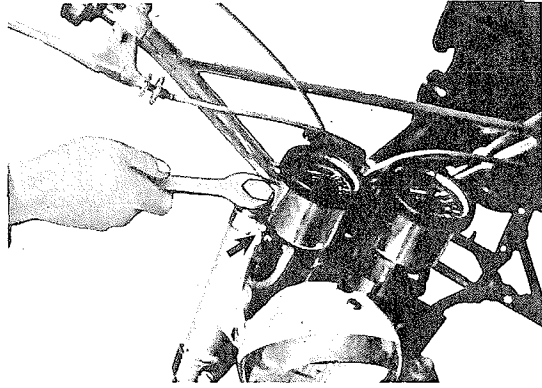

2) Loosen the inner tube pinch bolt on the underbracket.

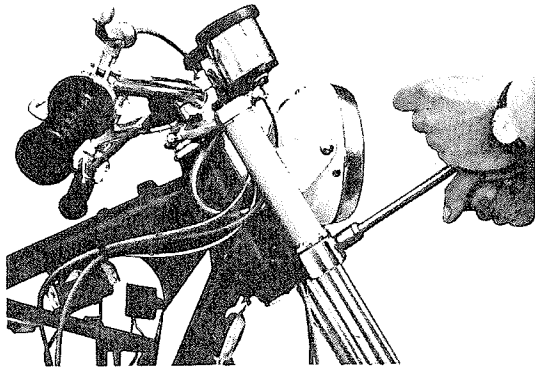

3) Pull the outer tube downward.

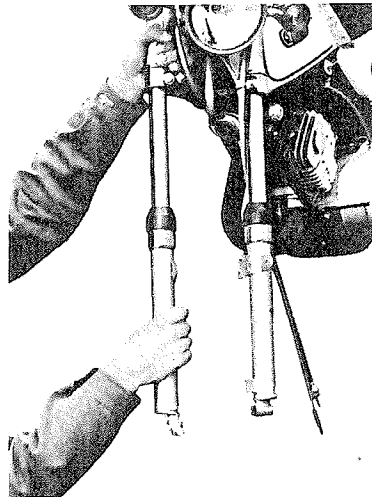

CHASSIS – Front Forks

B. Disassembling the Inner and Outer Tubes

- 1) Drain the oil from the fork.

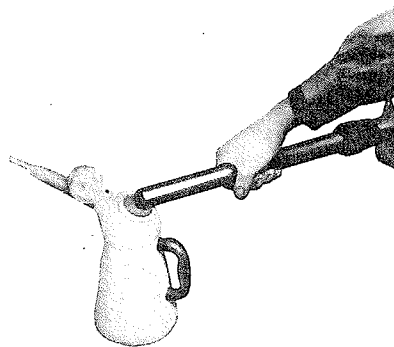

- 2) Remove the special bolt (arrow marked) from the bottom of the outer tubes.

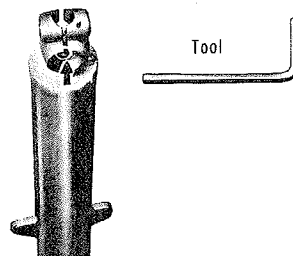

- 3) Place a rubber sheet or tire tube around the outer tube nut.

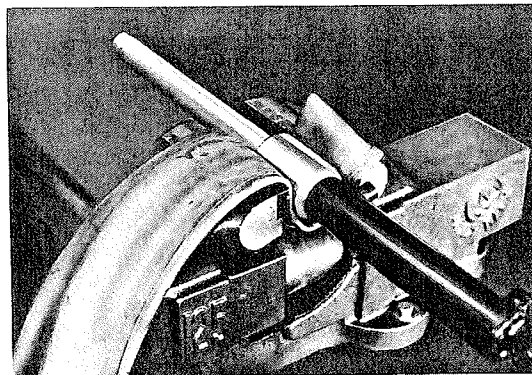

- 4) Squeeze the outer tube with a strap wrench, and turn it counter-clockwise. The inner tube can be separated from the outer.

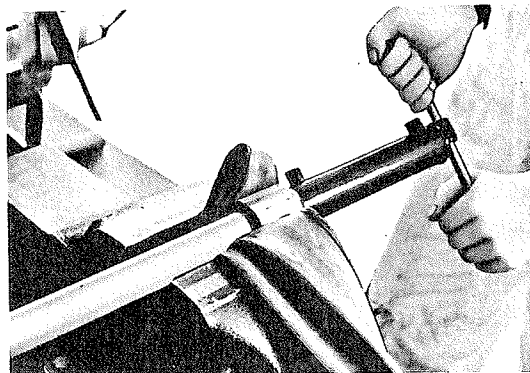

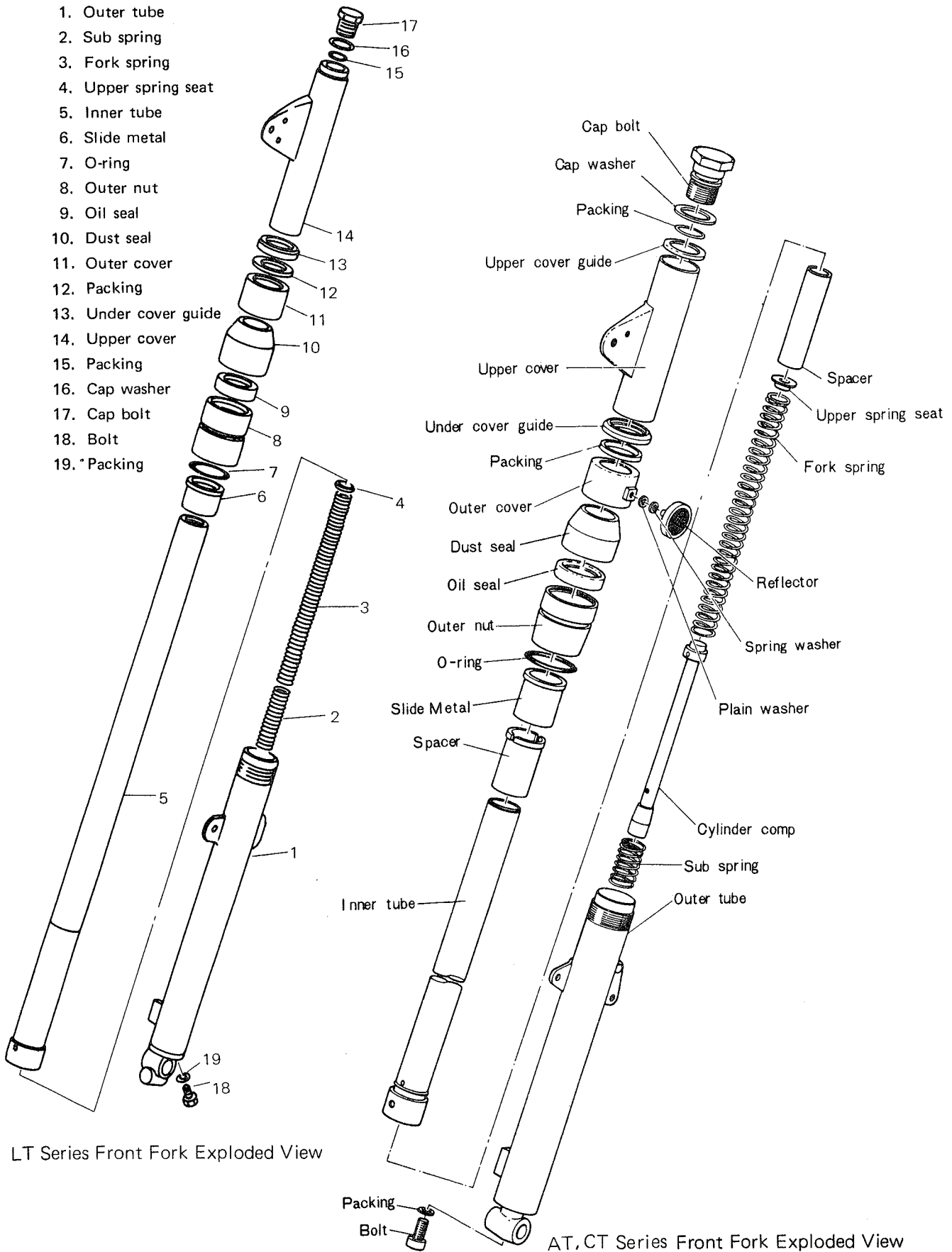

C. Checking

1) Inner tube

Check the inner tube for bends or scratches. If the bend is slight, it can be corrected with a press. It is recommended, however, to replace the tube if possible.

2) Oil seal

When disassembling the front fork, replace the oil seal in the outer tube nut.

D. Assembling

1) When assembling the front fork, reverse the order of disassembly. Check if the inner tube slides in and out smoothly.

2) Installing the front fork on the frame.

- a. Bring up the front fork to the correct position and partially tighten the underbracket mounting bolt.

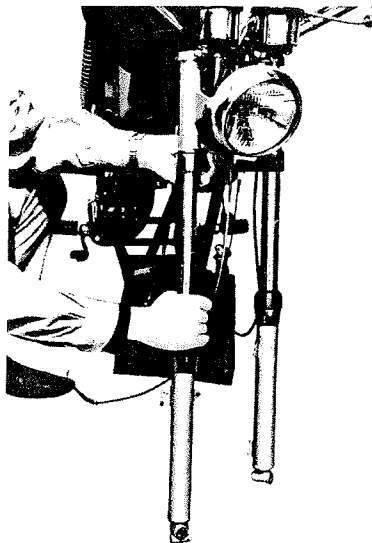

- b. Pour oil into the inner tube through the upper end opening. Front fork oil: Motor oil 10W/30 120 cc (4.1 fl.oz) per fork leg.

- c. Install the cap bolt, then completely tighten the lower and upper pinch bolts.

5-6 Rear Shocks

The rear shocks have a maximum stroke of 90 mm. (3.54 in.) AT/CT series; 80mm (3.15") on LT series. The rear cushion features superb damping and 5-position adjustable springs, that allow the rider to adjust the rear shocks to suit any riding condition.

A. Checking the Condition of the Damping Units.

- 1) Remove the rear shock assembly.

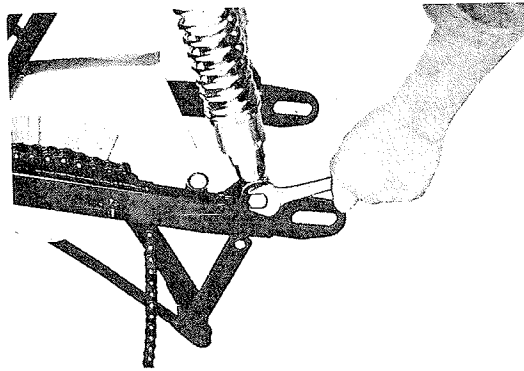

- 2) Compress the shock by applying weight and release it.

If the shock quickly restores halfway and then slowly returns to the original position, the rear shocks are in good condition. But if the cushion returns quickly to the original position, check the cushion for oil leakage, and replace the assembly if it leaks.

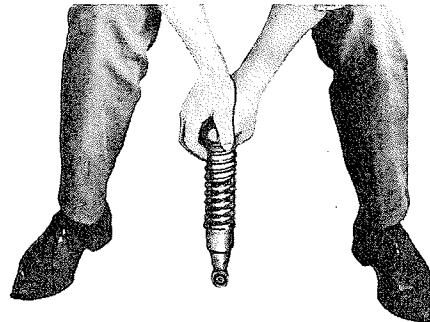

5-7 Gas Tank

The front of the tank is held to the frame by a hook on the tank that slips over a pin, and the rear is held by a rubber band.

A. Removing

- 1) Set the fuel petcock lever at the "Stop" position and disconnect the fuel line at the petcock.

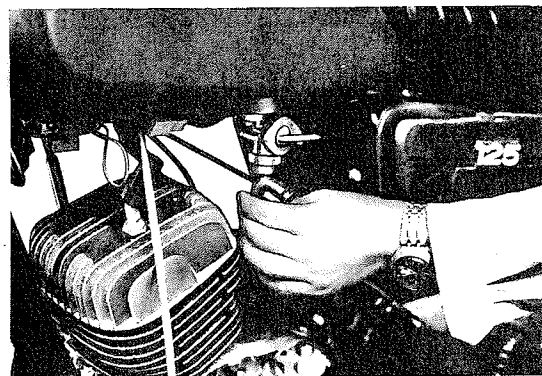

2) Open the seat.

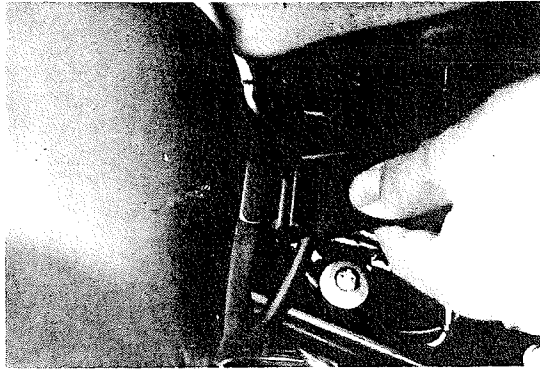

3) Remove the gas tank.

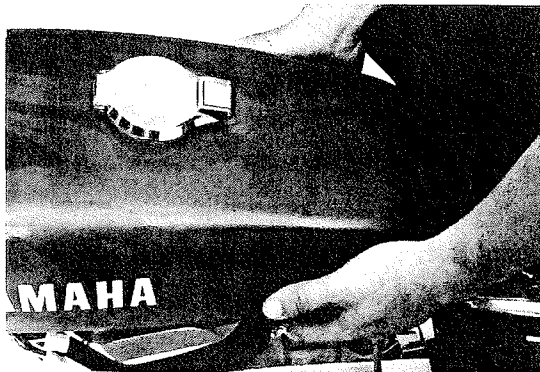

5–8 Rear Swing Arm

The rear swing arm is made of steel tube that improves the strength and torsional rigidity. The pivot employs permanently lubricated bearings.

A. Removing

- 1) Remove the chain case mounting bolts.

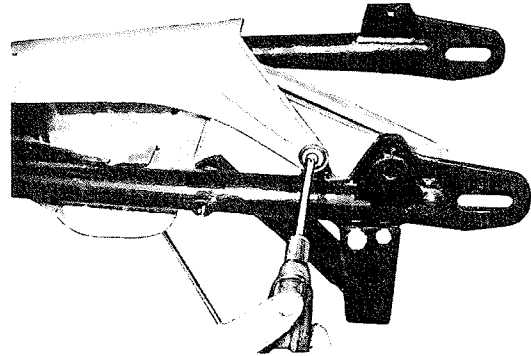

- 2) Remove the rear swing arm shaft nut, pull out the shaft, and remove the rear swing arm.

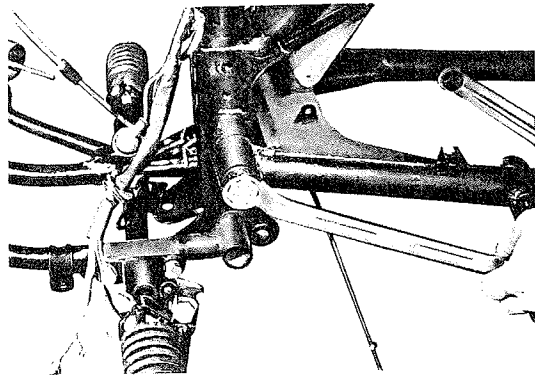

B. Checking

- 1) Check the play of the rear swing arm by shaking it from side to side, with the rear swing arm installed. If the play is excessive, replace the rear swing arm bushing or the rear swing arm shaft.
- 2) Insert the bushing as indicated and check it for play. If the play is excessive, replace the bushing.

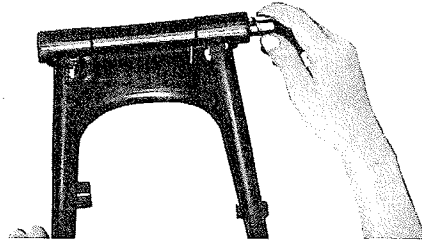
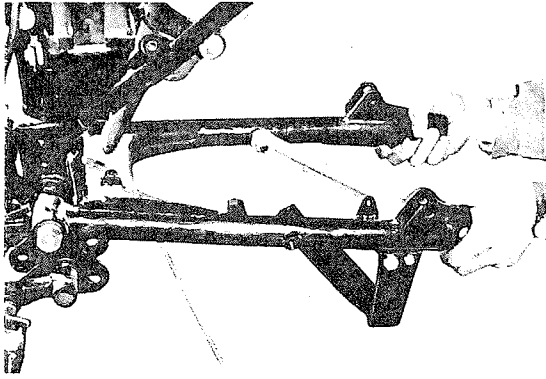

3) Grease the rear arm shaft periodically.

Replacing Rear Swing Arm Bushings

On motorcycles being used only for on-the-street riding, rear swing arm bushings should be replaced every 10,000 km. (6,000 miles). The same may not apply to those used for racing or rough riding. Replacement should be made according to machine condition such as excessive play of the rear swing arm, or hard steering (wander, shimmy or rear wheel hop,) or upon request of the customer.

5-9 Steering Head

A. Sectional View of the Steering Head

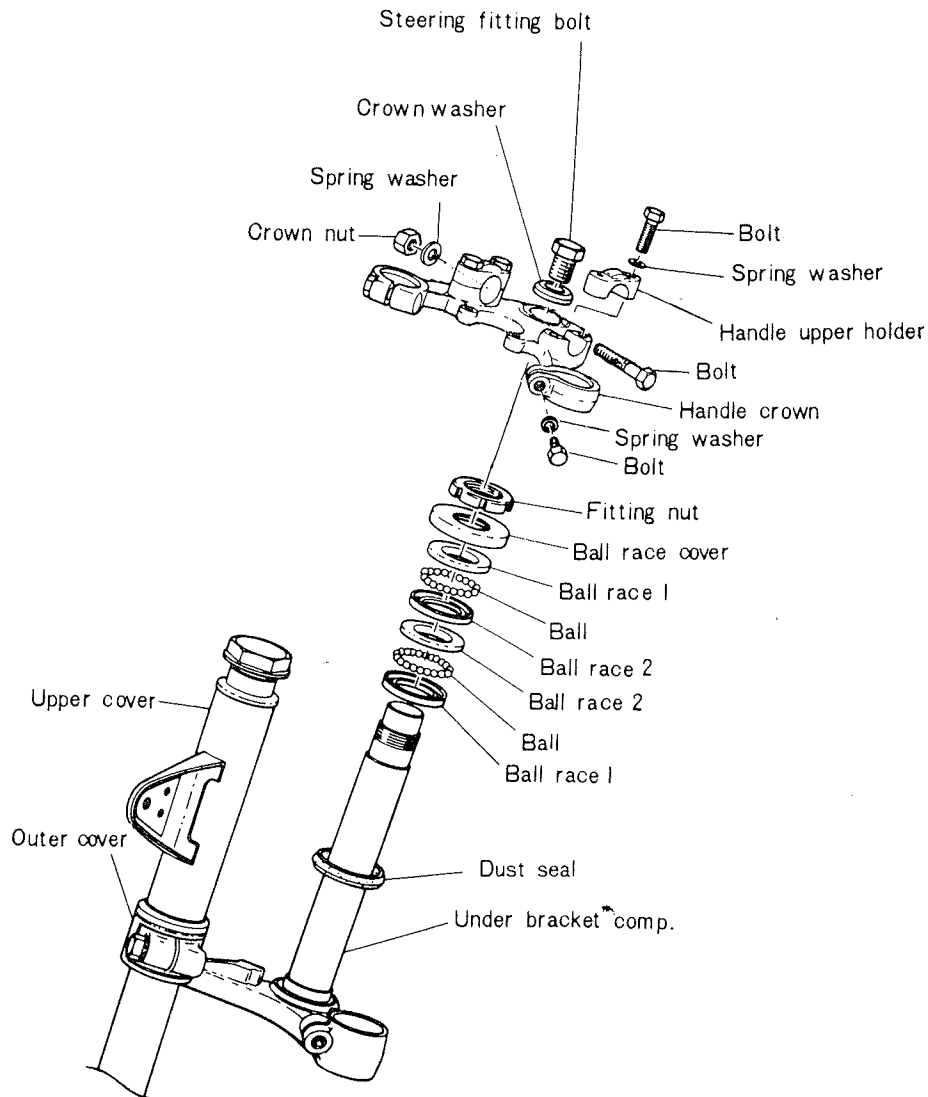

B. Checking

1) Ball Races and Steel Balls

Check the ball races and steel balls for pitting or wear. Check them very carefully if the machine has been in long use. If they are worn or cracked, replace all of them, because defective ball races or steel balls adversely affect the maneuverability of the machine. Replace any ball race having scratches or streaks resulting from wear. Clean and grease the balls and races periodically.

Note: Do not use a combination of new balls and used races or vice versa. If any of these are found defective, replace the whole ball and race assembly.

5–10 Oil Tank, Battery Box and Tool Box

The oil tank is located on the left side under the seat. It is designed to be as narrow as possible so that it will not contact the rider's lower limbs when he stands upright on the footrests. To fill the autolube oil tank, lift the seat and the tank cap will be exposed.

Oil tank capacity 1.2 litres. (1.3 u.s qts)

The battery box is located right under the seat.

And the tool box is located under cleaner box.

5–11 Frame

The double cradle-type frame is made of high tension steel tubes that provide strength, rigidity and light weight. Other dimensional features include high ground clearance, narrow width, and long wheelbase. The engine is bolted to the frame at three positions. The caster is measured at 60° 31'.

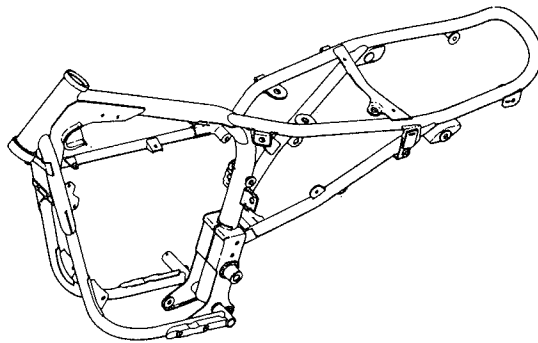

5–12 Handlebars

The upswept type longer handlebars are ideal for motocross events and are provided with deep-cut pattern grips to prevent hand slippage. The lever holder is provided with adjusting screws for clutch cable and brake cable free play.

The meter bracket is mounted on the ends of the handle crown, to carry the speedometer on its left side and the tachometer on its right side.

5–13 Miscellaneous

The footrest is made of a single steel tube extending under the lower part of the frame, and bolted to the frame. The engine guard is bolted to the frame to protect the entire crank-case covering from the exhaust system to the drain plug.

CHAPTER 6. ELECTRICAL SYSTEM FOR LT SERIES

6-1 Description

The LT series employ a flywheel magneto for its ignition system.

6-2 Table of Component Parts

Parts	Manufacturer	Model & Type
Flywheel magneto	Hitachi Ltd.	F-136-07
Spark plug	NGK	B-8HS
Headlight	Koito Mfg.	6V 25/25W Neutral pilot light 6V 3W
Speedometer	Nippon Seiki	Meter light 6V 3W
Handlebar switch	Asahi Denso	
Ignition coil	Hitachi Ltd.	CM-61-20H
Horn	Nikko Kinzoku	GF-6
Battery	Nippon Battery	DS10HJ7-8
Rectifier	Mitsubishi Elec.	DS 00HJ
Fuse	TAIKO Mfg.	10A x 2
Stop switch	Asahi Denso	
Taillight	Koito Mfg.	6V 17W/5.3W

6-3 Connection Diagram

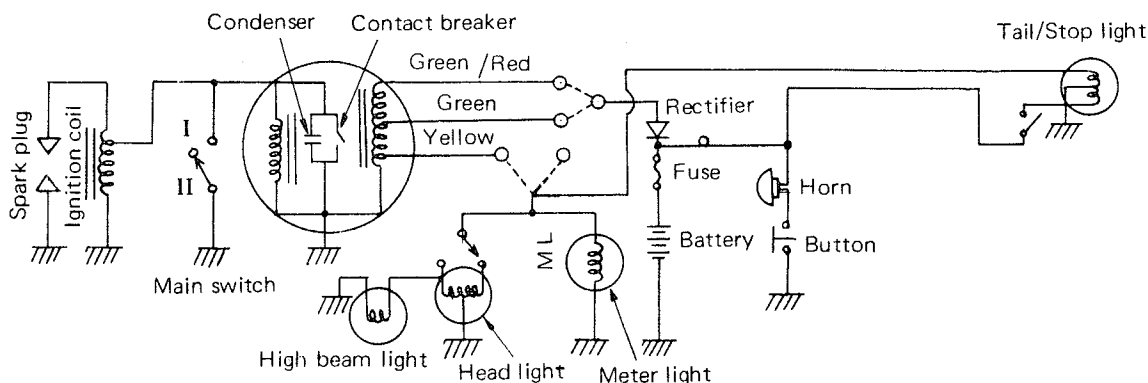

6-4 Ignition System—Function and Service

1. Function

The ignition system consists of the components as shown below. As the flywheel rotates, the contact breaker points begin to open and close, alternately. This make-and-break operation develops an electromotive force in the ignition power source coil, and produces a voltage in the ignition coil primary windings. The ignition coil is a kind of transformer, with a 1:50 turn ratio of the primary to the secondary winding. The voltage (150~300V) which is produced in the primary coil, is stepped up to 12,000~14,000V by mutual-induction and the electric spark jumps across the spark plug electrodes.

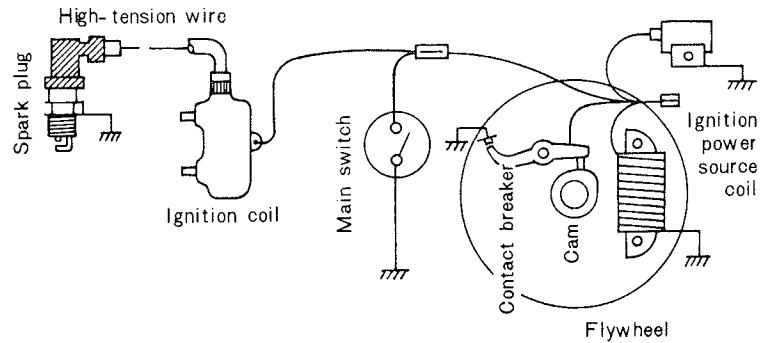

6-5 Ignition Timing

Remove the spark plug and screw the dial indicator holder into the plug hole. Next, insert the dial indicator into the holder. Bring the piston up to T.D.C. and set the zero on the dial face to line up exactly with the dial indicator needle. The crankshaft should then be turned backwards, so that the piston travels down past 1.8 mm B.T.D.C. and slowly brought back up to precisely 1.8 mm B.T.D.C. (This removes any slack in the gears). Adjust the points so that they are just beginning to open with the piston in this position. A low resistance point checker (100 Ohms or less) should be used to determine the opening and closing of the ignition points.

Ignition Timing, 1.8 mm. B.T.D.C.

Maximum ignition point gap 0.3 to 0.4 mm. (0.012" – 0.015")

6-6 Ignition Coil

Primary coil resistance value $4.9\ \Omega \pm 10\%$ (20 °C or 68 °F)

Secondary coil resistance value $11\ \text{K}\ \Omega \pm 10\%$ (20 °C or 68 °F)

(For measuring methods, refer to page.

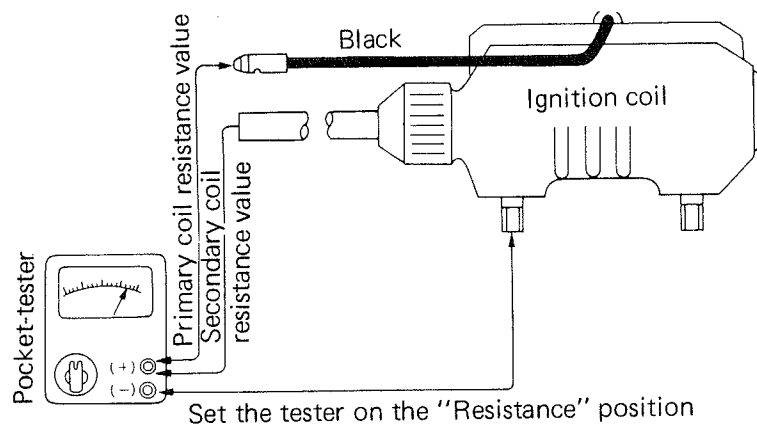

Spark Test:

Remove the spark plug from the cylinder head and reconnect the high voltage lead. Then hold the spark plug approximately 7 mm away from the head and see if it sparks as you crank the kickstarter. If it sparks at 7 mm, or so, and has blue white color, the ignition coil should be considered to be in good condition.

6-7 Condenser

The condenser instantly stores a static electric charge as the contact breaker points separate, and the energy stored in the condenser discharges instantly when the points are closed. If it were not for the condenser, an electric arc would jump across the separating contact points, causing them to burn.

Burned contact points greatly affect the flow of current in the primary winding of the ignition coil. If the contact points show excessive wear, or the spark is weak (the ignition coil is in good condition), check the condenser.

Insulation resistance tests should be conducted by connecting the tester as shown.

If the pointer swings fully and the reading is more than $3M\Omega$, the insulation is in good condition. If the insulation is faulty, the pointer will stay pointing at the uppermost reading, indicating very little resistance.

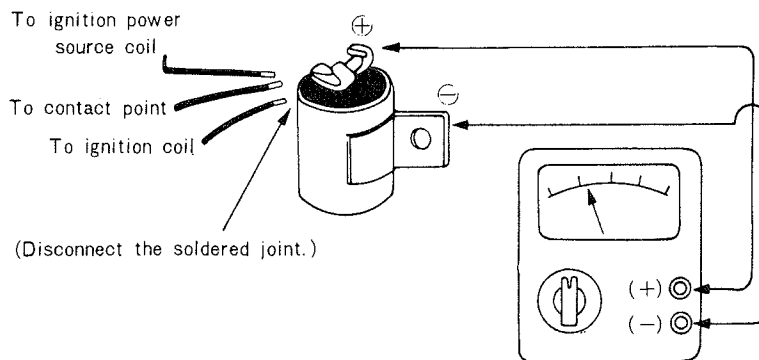

Note: After this measurement, the condenser should be discharged by connecting the positive and negative sides with a thick wire.

Capacity tests can be performed by simply setting the tester to the condenser capacity. The tester should be connected with the condenser in the same way as in the case of the insulation resistance test. Before this measurement, be sure to set the tester correctly.

If the reading is within $0.30\mu F \pm 10\%$, the condenser capacity is correct.

6-8 Charging System

The charging system consists of the flywheel magneto (charging and lighting coils), rectifier, and battery.

1. Flywheel Magneto

As the flywheel rotates, an alternating current is generated in the charging and, lighting coils and converted to a half-wave current by means of a silicon rectifier.

This half-wave current charges the battery.

Charging Capacity (Daytime)

Gear Lead: Charging begins at 2,500 rpm.

4.5 or less at 8,000 rpm.

ELECTRICAL SYSTEM FOR LT SERIES – Charging System

Charging Capacity (Night time)

Green/Red: Charging begins at 2,300 rpm.
 1.7A or less at 8,000 rpm.

Lighting Capacity (Night time) (With normal loads and normal wiring)

5.1V or more at 2,500 rpm.
 8.0V or less at 8,000 rpm.

* The charging and lighting capacity is obtained when the battery is fully charged. If the battery is in a low state of charge and low in voltage, the charging rate will be not exactly the same as above. However, it is desirable that the figures are as close as possible.

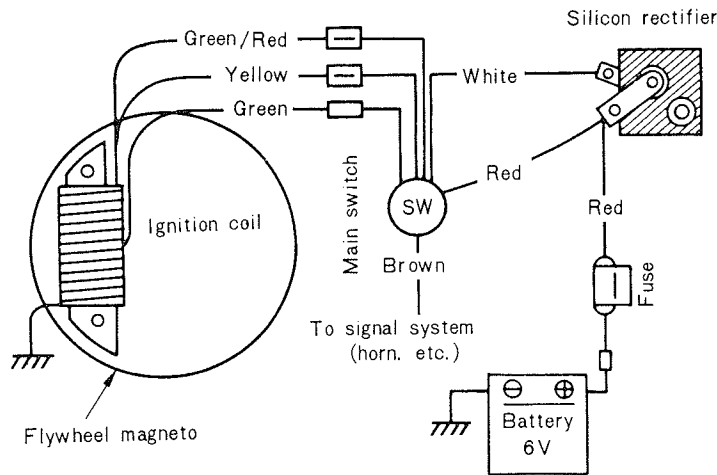

2. Silicon Rectifier

The alternating current, which is generated by the flywheel magneto, is rectified and charged to the battery. For this rectification, a singlephase halfwave silicon rectifier is employed.

Characteristics: Rated output – 4A,
 Rated peak inverse voltage – 400V

Polarity:

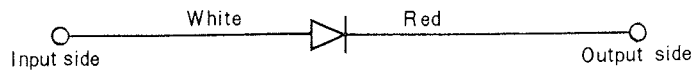

a. Checking the Silicon Rectifier

For measurements, an ohmmeter can be used.

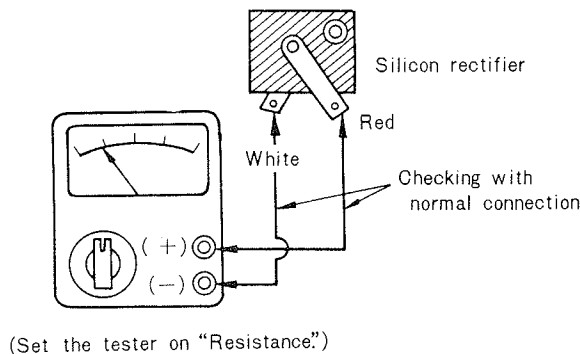

Checking with Normal Connection

Connect the tester's red lead (+) to the silicon rectifier's red terminal, and connect the tester's black lead (—) to the rectifier's white terminal.

Standard value: 9~10Ω

If the tester's pointer will not swing back over from the scale, the rectifier is defective.

Checking with Reversal Connection

Connect the tester the other way around.

Standard value: If the pointer will not swing, the rectifier is in good condition. If the pointer swings, the rectifier is faulty.

3. Operational Note

The silicon rectifier can be damaged if subjected to overcharging. Special care should be taken to avoid a short circuit and/or incorrect connection of the positive and negative leads at the battery. Never connect the rectifier directly to the battery to make a continuity check.

6-9 Battery

The battery is a 6 volt — 4AH unit that is the power source for the horn stoplight. Because of the fluctuating charging rate due to the differences in engine R.P.M.s, the battery will lose its charge if the horn and stoplight are excessively used. The charging of the battery begins at about 2,500 R.P.M. Therefore, it is recommended to sustain engine R.P.M.s at about 3,000 to 4,000 R.P.M. to keep the battery charged properly. If the horn and stoplight are used very often, the battery water should be checked regularly as continuous charging will dissipate the water.

1. Checking

- 1) If sulfation occurs on plates due to lack of battery electrolyte, showing white accumulations, the battery should be replaced.
- 2) If the bottoms of the cells are filled with corrosive material falling off plates, the battery should be replaced.
- 3) If the battery shows the following defects, it should be replaced.
 - The voltage will not rise to a specific value even after long hours charging.
 - No gassing occurs in any cell.
 - The 6V battery requires a charging current of more than 8.4 volts in order to supply a current at a rate of 1 amp. per hour for 10 hours.

2. Service Life

The service life of a battery is usually 2 to 3 years, but lack of care as described below will shorten the life of the battery.

- 1) Negligence in re-filling the battery with electrolyte.
- 2) Battery being left discharged.

ELECTRICAL SYSTEM FOR LT SERIES – Checking the Main Switch

- 3) Over-charging by rushing charge.
- 4) Freezing.
- 5) Feeding of water or sulfuric acid containing impurities when re-filling the battery.

3. Storage

If any motorcycle is not used for a long time, remove the battery and have it stored by a battery service shop. The following instructions should be observed by shops equipped with chargers.

- 1) Recharge the battery.
- 2) Store the battery in a cool, dry place, and avoid temperatures below 0°C. (32°F)
- 3) Recharge the battery before mounting it on the motorcycle.

4. Service Standards

Battery Spec	6V-4AH	
Electrolyte-Specific gravity and 1.26–1.27, 110 c.c. quantity		At full charge
Initial charging current	0.2A for 25 hours	Brand new motorcycle
Charging current	0.2A for 13 hours (Charge until specific gravity reaches 1.26–1.26)	When discharged
Refilling of electrolyte	Distilled water up to the max. level line.	Once a month

6–10 Checking the Main Switch (removed from the chassis)

Key "Off" position

B/W ↔ B

Key "I" position

R ↔ Br

G ↔ W

Key "II" position

R ↔ Br

R ↔ L

Br ↔ L

W ↔ Gr

LW ↔ Y

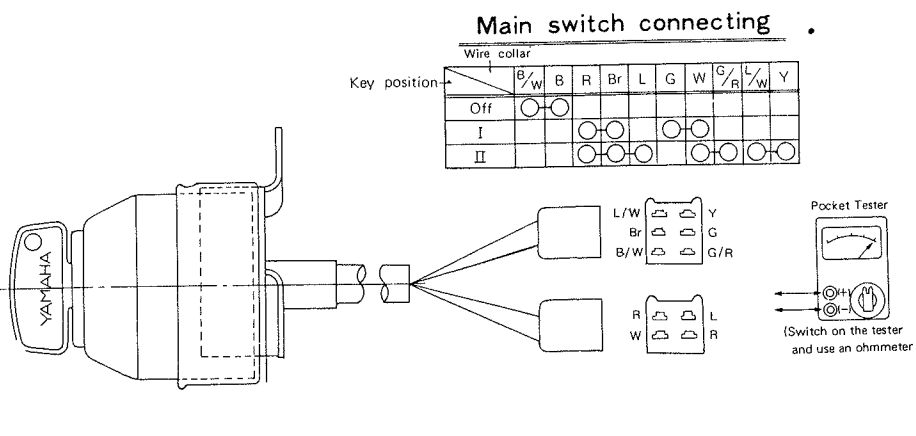

If the readings or the above eight measurements are nearly 0Ω, and no short-circuit is noticed between the terminals, as well as between the lead terminal and the switch body, the main switch is in good condition.

6-11 Spark plug

The life of a plug and its discoloring vary, according to the habits of the rider. At each periodic inspection, replace burned or fouled plugs with suitable ones determined by the color and condition of the bad plugs. One machine may be ridden only in urban areas at low speeds, whereas another may be ridden for hours at high speeds, so confirm what the present plugs indicate by asking the rider how long and how fast he rides, and recommend a hot, standard, or cold plug accordingly. It is actually economical to install new plugs every 3,000 km. (2,000 miles) since it will tend to keep the engine in good condition and prevent excessive fuel consumption.

1. How to "read" spark plug (condition)
 - a. Best When the porcelain around the center electrode is a light tan color.
 - b. If the electrodes and porcelain are black and somewhat oily, replace the plug with a hotter-type for low speed riding.
 - c. If the porcelain is burned white and/or the electrodes are partially burned away, replace the plug with a colder-type for high speed riding.

2. Inspection

Instruct the rider to:

Inspect and clean the spark plug at least once a month or every 1,000 km. (600 miles).

Clean the electrodes of carbon and adjust the electrode gap to 0.5~0.6 mm. (0.023 in.).

Be sure to use standard B-8HS plug as replacement to avoid any error in reach.

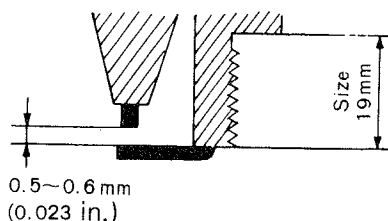

6-12 Lighting and Signal Systems

The lighting and signal systems consist of the horn and stoplight (power source – battery and the headlight, taillight, meter lamps, speedometer.

1. Headlight

The headlight has two 6V, 25W bulbs, and a 6V, 1.5W neutral pilot light on its top. A beam directing adjusting screw is fitted on the right side of the light rim so that the horizontal direction of the beam can be adjusted (not vertically).

2. Taillight and Stoplight.

A 6V, 5.3W taillight and a 6V, 17W stoplight are mounted. The lens of the taillight is provided with reflectors on its three sides – rear, right and left.

3. Horn

The horn is a 6V, flat type, and has a tonevolume adjusting nut on its back.

After adjustment is made, apply paint or lacquer to the nut for water proofing purposes.

4. Speedometer

A circular type speedometer is mounted on the bracket. For illumination, a 6V, 3W bulb is provided.

CHAPTER 7. ELECTRICAL SYSTEM FOR AT SERIES

7-1 Description

The YAMAHA AT series are equipped with a large-sized starter dynamo, which serves as a high-output D-C generator as well as a starter. This enables all electrical terminals to keep voltages almost constant at all times regardless of engine speeds.

All electrical parts are of 12-V capacity.

7-2 Table of Component Parts (AT1-C)

Parts	Manufacturer	Model & Type	Remarks
Starter dynamo Spark plug	Hitachi Ltd. NGK	GS114-01 B-8E	
Head light	Koito Mfg.	12V25WD High beam indicator light 12V 1.5W	Is interchangeable with DT1
Speedometer	Nippon Seiki	Meter light 12V3W	
Tachometer	Nippon Seiki	Meter light 12V3W	
Left handlebar switch Right handlebar switch	Asahi Denso Asahi Denso		
Main switch	Asahi Denso	CM-11-50	Is interchangeable with A7
Ignition coil Horn	Hitachi Ltd. Nikko Kinzoku	MF-12	
Battery	Furukawa Battery	12N7-3B1-1, 12V7AH	
Regulator	Hitachi Ltd.	T107-17	
Starting switch	Hitachi Ltd.	A104-35	
Fuse	TAIKO Mfg.	20Z x 2	
Front stop switch	Asahi Denso	12V 7W/23W	Is interchangeable with DT1B
Rear stop switch	Asahi Denso		
Tail/Stop light	Stanley Elec.		

Table of Component Parts, Main
Components, Charging and start-
ing System

ELECTRICAL SYSTEM FOR AT SERIES

7-3 Table of Component Parts (AT2, AT3)

Parts	Manufacturer	Model & Type	Remarks
Starter dynamo	Hitachi Ltd.	M100-03	Metal-back sealed beam Is interchangeable with DT1
Spark plug	NGK	B-8ES	
Head light	Koito Mfg.	12V25WD High beam indicator light 12V2W	
Speedometer	Nippon Seiki	Meter light 12V3W	
Tachometer	Nippon Seiki	Meter light 12V3W	
Left handlebar switch	Asahi Denso		
Right handlebar switch	Asahi Denso		
Main switch	Asahi Denso		
Ignition coil	Hitachi Ltd.	CM-61-50	
Horn	Nikko Kinzoku	MF-12	
Battery	Furukawa Battery	12N7-3B1-1,12V7AH	
Regulator	Hitachi Ltd.	T107-17A	
Starting switch	Hitachi Ltd.	A104-35	
Fuse	Osachi Mfg.	20A x 2	
Front stop switch	Asahi Denso		Is interchangeable with DT1
Rear stop switch	Asahi Denso		
Tail/Stop light	Stanley Elec.	12V 7/27W	(TRADE No.1157)

7-4 Main Components

1. Ignition System

The main parts consist of:

Contact breaker (connected to the dynamo)

Condenser (connected to the dynamo)

Ignition coil, spark plug, high tension lead, and battery.

7-5 Charging and Starting System

Charging system: The purpose of the charging system is to charge the battery equipment (lights, horn, etc) while the machine is running.

ELECTRICAL SYSTEM FOR AT SERIES – Connection Diagram

Starting system: Electric starter system is used to crank the engine.

The main parts of these two systems are:

Dynamo (yoke, armature, brushes), regulator (with cutout relay), starter button (with starting switch), fuse and battery (power source).

3. Lighting and Signal Systems

The lighting and signal systems consist of signal lights, switch and meter lights (signal system) and illumination lights for night travel.

Signal system: Horn, stoplight, and switches.

Lighting system: Headlight, taillight, and meter lights.

7-6 Connection Diagram (AT1-C)

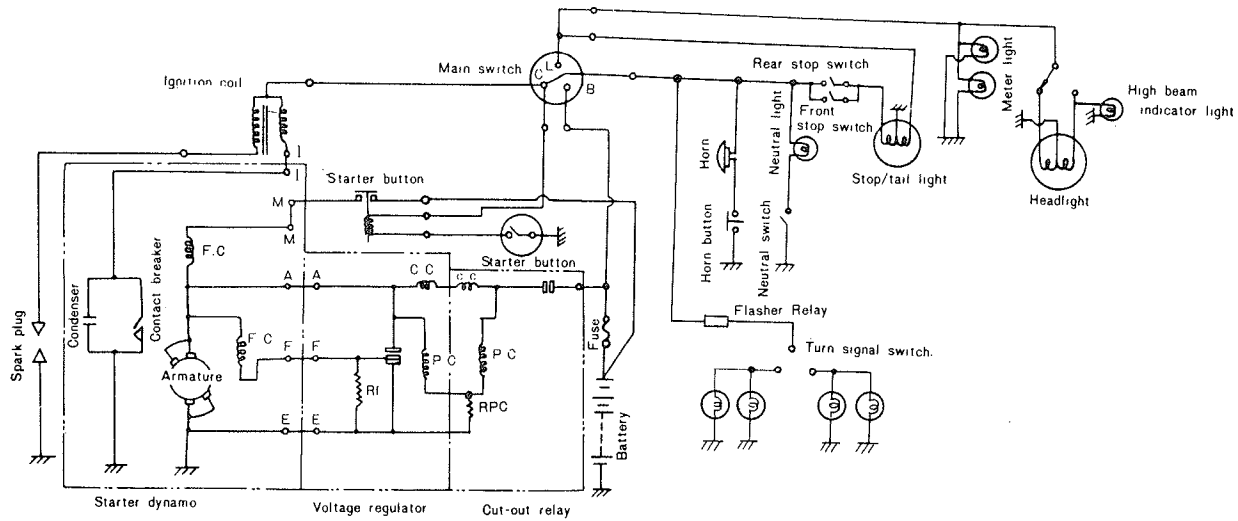

7-7 Connection Diagram (AT2, AT3)

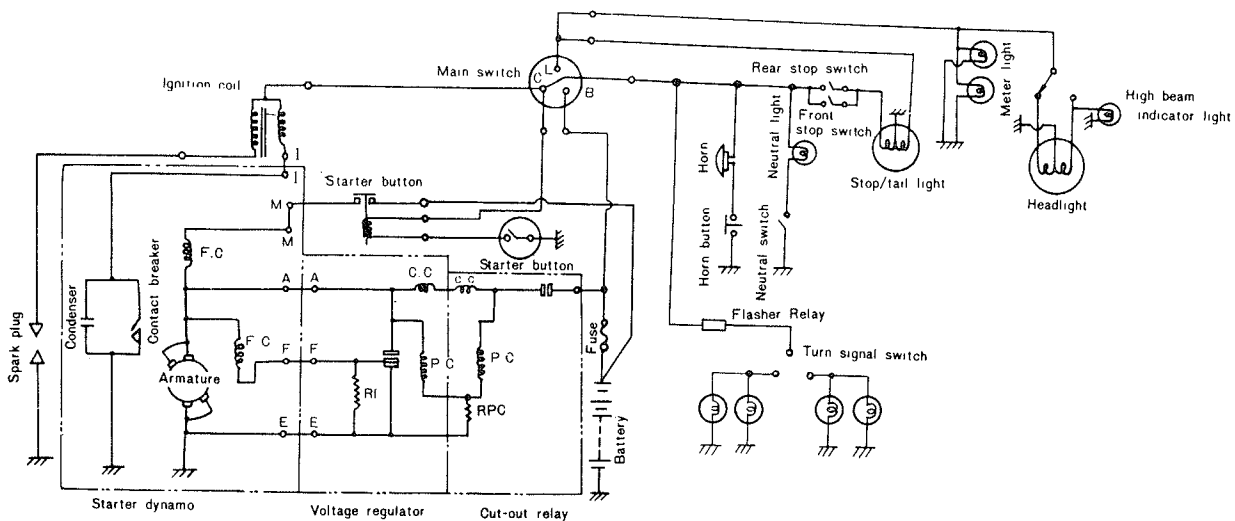

6-8 Starter Dynamo

The dynamo ass'y is made up of the yoke ass'y (field coil, contact breaker, condenser, etc), the armature ass'y (armature coil, commutator) and the cam ass'y, and supplies power to the ignition and charging systems.

Ignition system:

The ignition system consists of the contact breaker, condenser, and cam. The system interrupts the current flowing from the battery to the primary coil, thereby inducing a high voltage charge in the secondary coil.

a. Contact Breaker Ass'y

Incorrect ignition timing results in irregular engine speeds, thereby causing an engine knock or vibrations. It also causes loss of engine power or engine overheating, thus shortening engine life. Check the contact breaker periodically.

b. Condenser

The condenser stores electricity from the breaker points when the points open, and discharges the static when the points close. It prevents sparking between the points, minimizing burning by absorbing an abrupt increase in electricity when the breaker points open, and it amplifies the effect of the primary ignition coil.

Charging System:

The charging system of the starter dynamo consists of the yoke ass'y (shunt field coil and brushes) and the armature ass'y (commutator). The armature coil cuts through the magnetic lines of force of the field coil as the engine runs so that a flow of alternating current is induced. The alternating current is converted into a direct current through the commutator brushes. The direct current voltage is kept constant by the voltage regulator, and supplied to each load of the ignition, lighting and signal systems as well as to the battery.

Starting System:

In the starting system of the starter dynamo, the series coil and the armature, working as a D.C. motor, generate a great amount of torque, by which the engine is cranked.

1. Inspection and Repairs

A. Checking the Dynamo

First disconnect the wires from the terminals A (white) and F (green), then ground the terminal F to E

(black), with a jumper wire. Connect the positive lead of the tester to terminal A (white), and ground the negative tester lead to the engine. Start the engine and keep it running at 2,000 rpm. If the electricity generated reads more than 14V on the tester, the generator is in good working condition.

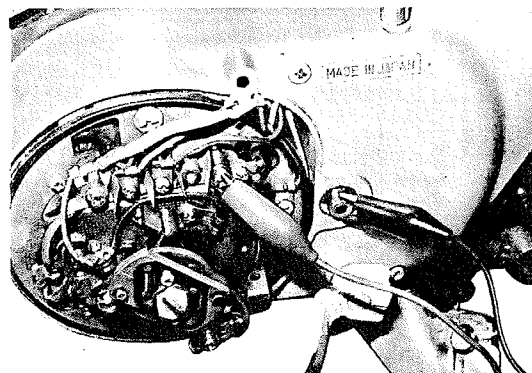

Caution: Do not run the engine at more than 2,000 rpm in this test. If you run the engine at more than 2,000 rpm, a high voltage current generated will ruin the coil, lead wire, etc.

B. Checking the Yoke Ass'y

Clean the yoke with a rag to remove dust, oil, and carbon from brush wear, etc.

1) Field Coil Brush Insulation Test

The positive brush of the field coil is insulated from the yoke and by using the tester, you can check its insulation. If the insulation is bad, the circuit between the field coil or the brush holder, and the yoke is shorted.

(Note: The negative brush is not insulated.)

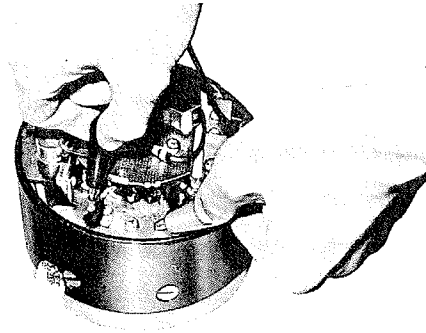

2) Conductivity Test of Field Coil

Check the continuity between the terminals M, A, and F. If continuity is bad, the field coil is broken. Check the visible coil connections. If the coil connections are good, then the coil is broken inside and it should be replaced because repairs are very difficult.

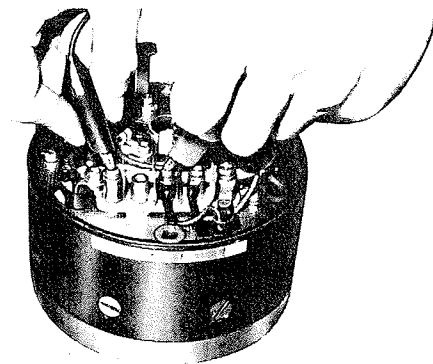

3) Checking the Brushes

The brushes are one of the most important parts in the dynamo. Take out the brushes and check the condition of their contact surfaces. Each brush must contact the commutator with more than $\frac{3}{4}$ of its surface area.

If both brush and commutator surfaces are rough, check both the crankshaft and armature for alignment. Smooth down any burrs on the edge of the armature's tapered bore, and clean it thoroughly.

If either brush is worn past the minimum length mark, replace them both with new ones.

4) Materials of the Brush

Use the brush having the model No. "MH-33" on its side.

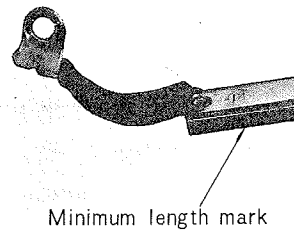

5) Handling the Brushes

When replacing the brushes, be sure the braided lead of the positive brush does not touch the edge of the breaker plate or brush holder, and that the lead of the negative brush does not touch the positive brush spring.

The friction of the braided lead against other parts as a result of vibrations may wear through the insulation and cause a short circuit.

C. Checking the Armature Ass'y

- 1) Thoroughly clean the commutator of oil and dirt. If the commutator is rough or dulled with brush dust, polish it with fine grain sandpaper (#400-600) by rotating the armature. Partial polishing will only deform the commutator and shorten brush life.

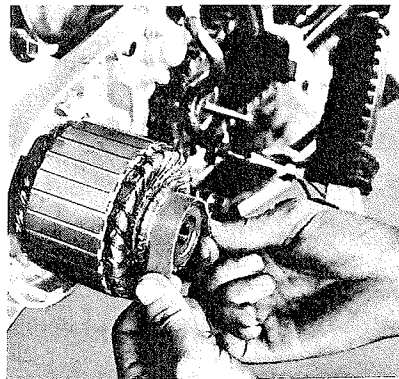

If the commutator is burned, out of round, or too rough to be sandpapered, turn it on a lathe no more than 2 mm under the standard 40 mm diameter.

- 2) Checking the Commutator Mica Under-Cut

If the commutator is worn and if it has high mica, the mica should be undercut with a saw blade:

Sand off all burrs with sandpaper. be sure the mica is cut away clean between segments, leaving no thin edge next to segments.

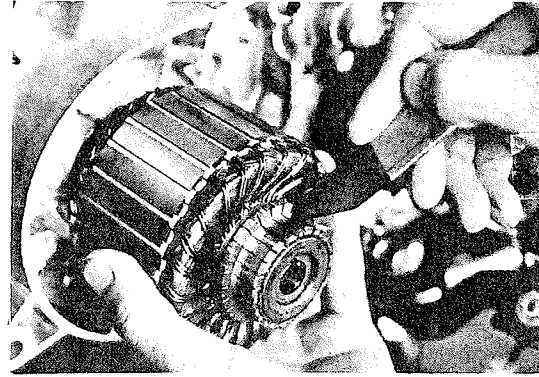
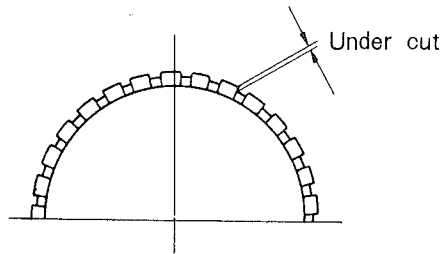

Mica undercut inspection limits: 0.5-0.8 mm

Mica undercut correction limits: 0.2 mm

3) Checking the Armature for Insulation

If there is electrical leakage between the commutator and shaft, replace the whole armature.

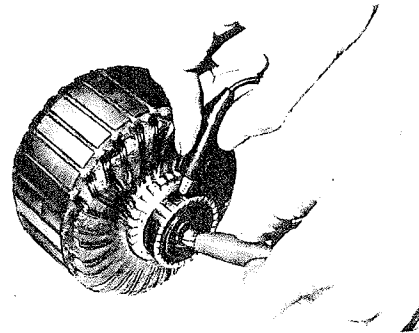

4) If the field coil is perfectly insulated and conductivity is also good, but the dynamo will not generate electricity, the core of the armature coil might be short-circuited.

Check the armature with a growler at a special service shop.

D. Checking the Condenser

1) Insulation Tests

Hook up an electro tester (service tester) for the insulation resistance test, and attach the tester terminals to those of the condenser. If the tester needle swings once and then returns to its original position, the condenser is in good condition. Condenser leakage will hold the needle at a maximum reading. If the reading is more than $3M\Omega$, the condenser is good. Ground the condenser terminals to discharge the stored electricity.

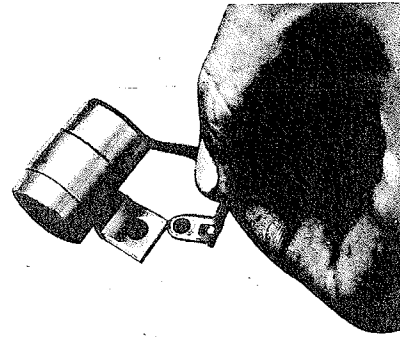
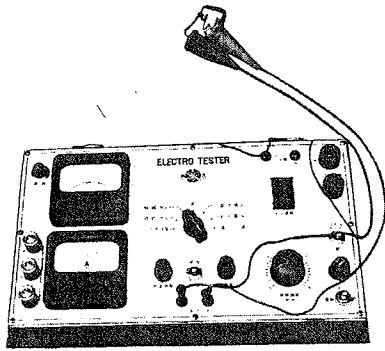

2) Capacity Tests

Set the service tester for the condenser capacity position, and connect its terminals to those of the condenser.

Condenser capacity should be no more than $0.22\mu\text{F} \pm 10\%$. Before testing the condenser, adjust the capacity of the service tester.

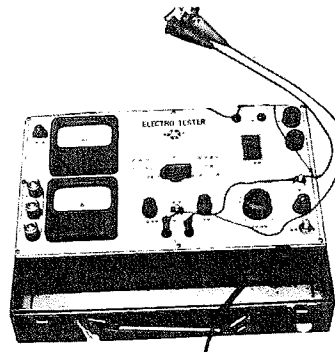
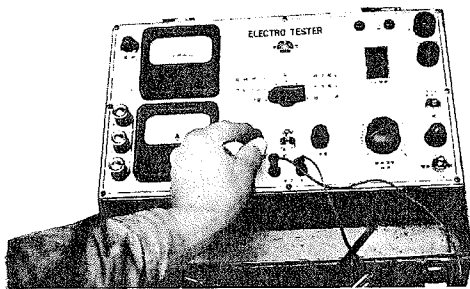

Note: When you make this test with the condenser mounted on the dynamo, disconnect the wires from the terminals, and insert a piece of cardboard between the breaker points.

In this test, the insulation resistance of the contact breaker can be tested at the same time. If the insulation resistance is too low, disconnect the lead wires from the condenser, and test it again.

E. Contact Breaker

- 1) Periodically inspect the breaker points and check the point gap, If the gap is incorrect, adjust it.
- 2) Periodically inspect the breaker points for any pitting.

Excessive pitting should be smoothed out with sandpaper (#400-600), and wiped off with soft cloth.

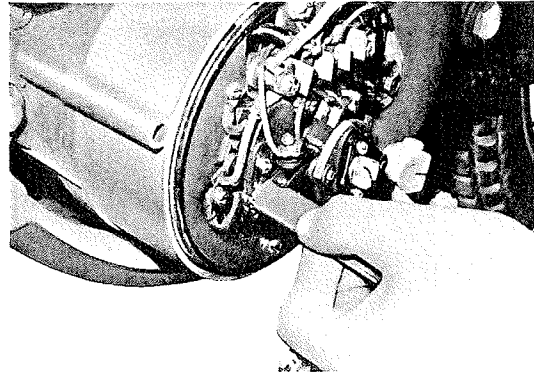

- 3) After every 5,000 km (3,000 miles) inspect the breaker cam lubricator and grease it a little.
- 4) Oil or dust on the points impairs spark performance.
The oil on the points will considerably shorten point service life. Wipe it off from time to time.

F. Adjusting Ignition Timing

1) Tools and instruments for adjusting:

Dial gauge (accuracy-1/100 mm)

Dial gauge adapter

Continuity testing lamp, YAMAHA electro tester or YAMAHA point checker

Point wrench

Slot-head screw driver

12mm wrench

2) Adjust ignition timing

- a) Set the point gap at 0.30-0.40 mm (0.012~0.014")
- b) Remove the spark plug and screw the dial indicator holder into the plug hole. Next, insert the dial indicator into the holder. Bring the piston up to T.D.C. and set the zero on the dialface to line up exactly with the dial indicator needle.

Remove the lead wire from terminal I. Connect the positive (+) tester lead to the terminal I, and ground the tester's negative lead to the frame.

- f) Turn the crankshaft back well past 1.8 mm, to eliminate play in the gears, and then bring the piston up to exactly 1.8 mm B.T.D.C.

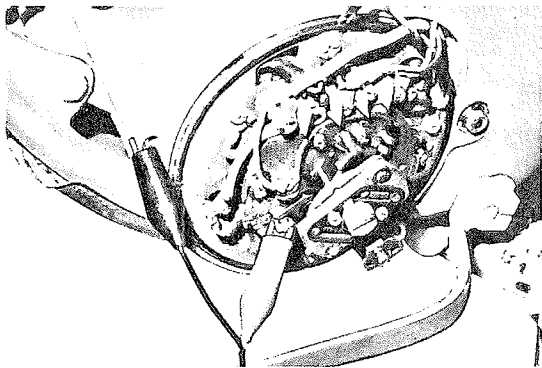
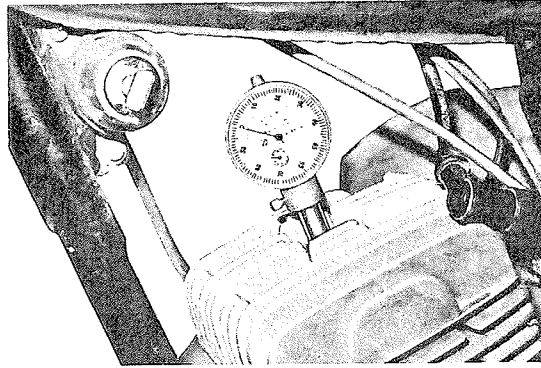
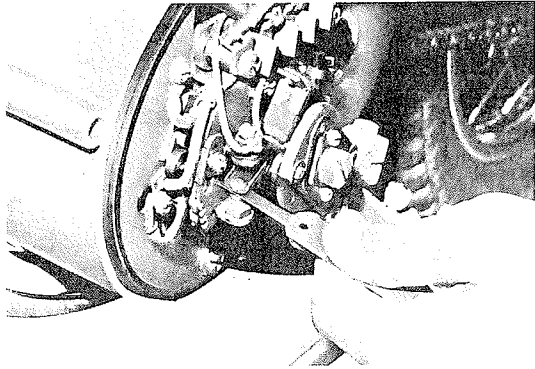

- d) Wedge the governor, fully open. Then loosen the breaker plate holding screws, and turn the breaker plate. When the points just start to open (the testing lamp lights up), tighten the holding screws. (Do not fully loosen the breaker plate holding screw, because the breaker plate tends to shift its position). Turning the breaker plate in the engine rotation direction causes ignition timing to delay, and turning it in the opposite direction advances ignition timing. Tighten the screws, and recheck the adjustment.

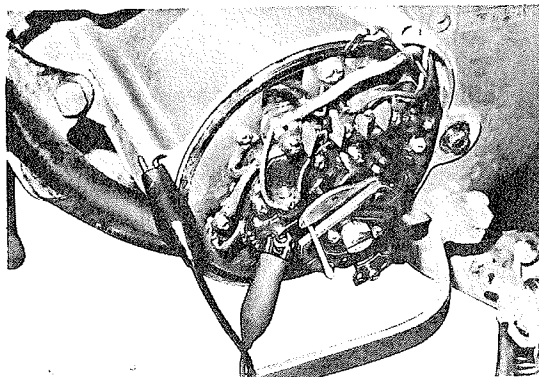

ELECTRICAL SYSTEM FOR AT SERIES— Starter Dynamo

8) Dynamo Adjustment Standards

Part	Item	Maintenance	Inspection
Field	Resistance Shunt Series	4.8Ω@20°C (68°F) 0.0268Ω @20°C (68° F)	When voltage is irregular
Brushes	Material Number Width x thickness x length Minimum length Spring capacity	MH-33 4 9 x 4.5 x 20.5 mm 9 mm 400 ± 10%-560 ± 10% (initial use)	First 6,000 km (4,000 mi.) Every 4,000 km thereafter (2,500 mi.)
Commutator	Diameter Minimum diameter Mica undercut Minimum mica undercut Difference between max. and min. diameter	38.5 ϕ mm 36.5 ϕ mm 0.5-0.8 mm 0.2 mm 0.03 mm	
Breaker	Point gap Point pressure Ignition timing Automatic spark advance	0.30-0.40 mm 800 ~ 1,000 g BTDC 1.8 mm Starting 1,350 ± 150 rpm Final 1,600 ± 100 rpm Advance 12 ± 2°	Every 3,000 km (2,000 mi.) (High rpm irregular) (Ignition irregular)
Others	Dynamo dia. (outer) Armature taper Cut-in rpm	130 ± mm 20 ϕ x 1/5 2,000 rpm	
Capacity	Rated output rp,	14V/2,000 rpm	

7-9 Regulator (Voltage Regulator)

The dynamo alone can not provide stable electric current because fluctuating engine rpm affects the voltage. The regulator (also called a voltage relay) stabilizes the voltage generated by breaking the field coil circuit when the voltage exceeds a pre-set level.

A cutout relay (also called a charging relay) is built into the regulator. It allows stable electric current from the dynamo to charge the battery. However, when the engine stops, or when its speed is so low that the dynamo output is lower than that of the battery voltage, it breaks the circuit to the battery so the battery will not drain. The starting switch is provided to direct a flow of current to the starter dynamo when the engine is started.

1. Inspection and Adjustment

If the regulator can no longer control the voltage, the battery will be drained or over-charged, and all electrical parts may be burned out. So use a good tester when inspecting or adjusting the regulator. (It is advised that you learn how to adjust the regulator at training courses because it is very difficult.)

A. No-Load Voltage

1) Inspection

- Disconnect the lead wire (red) of the regulator and connect the positive tester lead to the lead wire (red). Then ground the negative tester lead.
- Start the engine and keep it running at 2,500 rpm. Your regulator is correct if the tester reads 15.8-16.5 V.
- Start the engine and keep it running at 5,000 rpm. Your regulator is correct if the tester reads less than 16.9V.

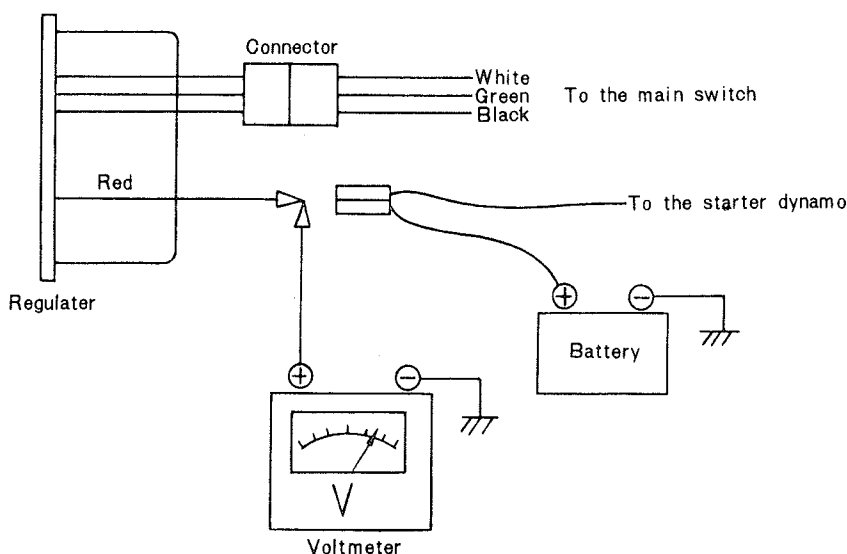

2) Adjustment

If the measured voltage is more or less than specified, adjust it by tightening or loosening the adjusting screw on the voltage relay side.

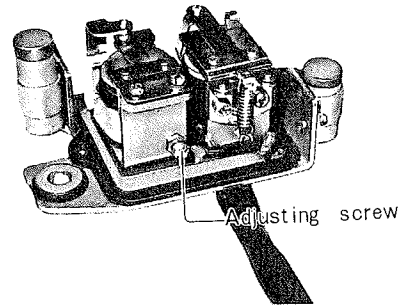

B. Cut-in voltage of the Cutout Relay

1) Inspection

Disconnect the lead from the dynamo A terminal, connect the tester positive lead to the A terminal, then ground the negative lead to the engine.

Start the engine, and increase engine speeds slowly. The cutout relay is correctly set if its breaker points close at 12.5-13.5 V.

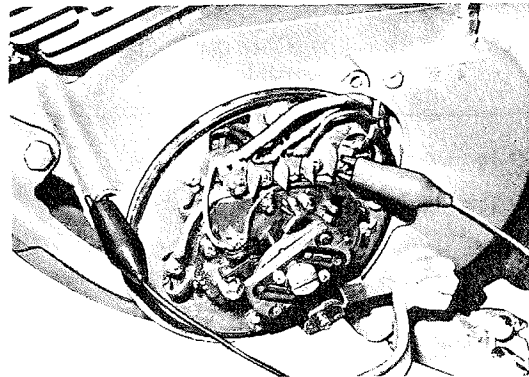

2) Adjustment

If the breaker points will not close at the specified voltage, adjust the cutout relay by changing its spring tension.

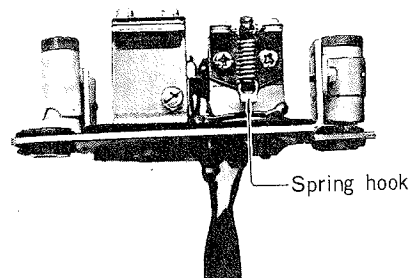

In actual practice, there will rarely be need to adjust the cutout relay.

If the point surfaces of the voltage and cutout relays are worn or pitted, polish them with fine sandpaper (#400-600) before making any adjustment.

ELECTRICAL SYSTEM FOR AT SERIES – Ignition Coil

3) Regulator Maintenance Standards

	Item	Maintenance standards	Inspection
Voltage regulator	No load voltage adjustment value	15.8-16.5V/2,500 rpm	When voltage is irregular
Voltage relay	Voltage coil resistance value	11.8Ω/20°C (68°F)	
	Compensation value	10Ω/20°C (68°F)	
	Core gap Point gap	0.4-0.7 mm 0.4-0.5 mm	
Cutout relay	Cut-in voltage	13 ± 0.5V	
	Reversing current	5A or less	
	Voltage coil resistance value	11.2Ω/20°C (68°F)	
	Core gap Point gap	0.8-1.0 mm 0.6~0.8 mm	

7-10 Ignition Coil

The ignition coil is a kind of transformer, with approximately 50 times the number of windings in the secondary coil as in the primary. If the electric current supplied to the primary coil (from the battery) is interrupted by a contact breaker, the primary coil will create a 150 - 300 V current by self-induction. This current is boosted to 12,000 - 14,000 V by mutual induction in the larger number of secondary coil windings, thereby making spark jump the plug electrodes.

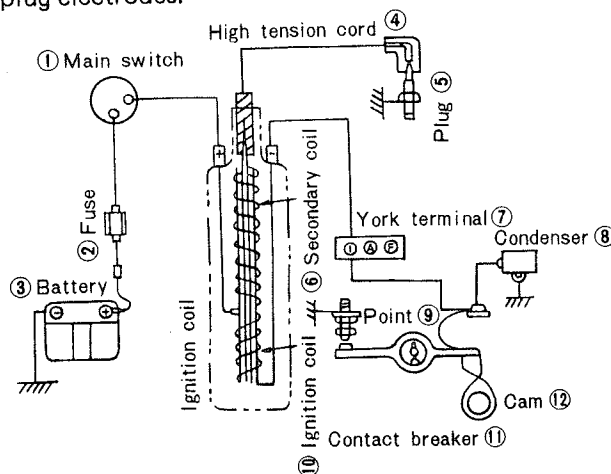

1. Inspection

If no spark, or weak spark jumps the plug gap, inspect the ignition coil as well as the contact breaker.

- a. When you test the coil alone, use a 12V battery as power source.

A spark of 7 mm or more means the coil is in good condition.

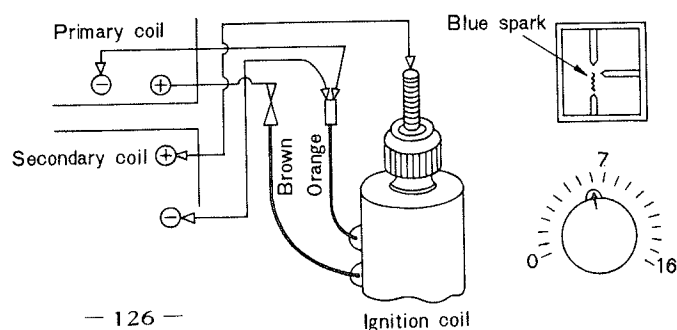

ELECTRICAL SYSTEM FOR AT SERIES – Checking the Main Switch

b. Test with Coil Installed (practical test)

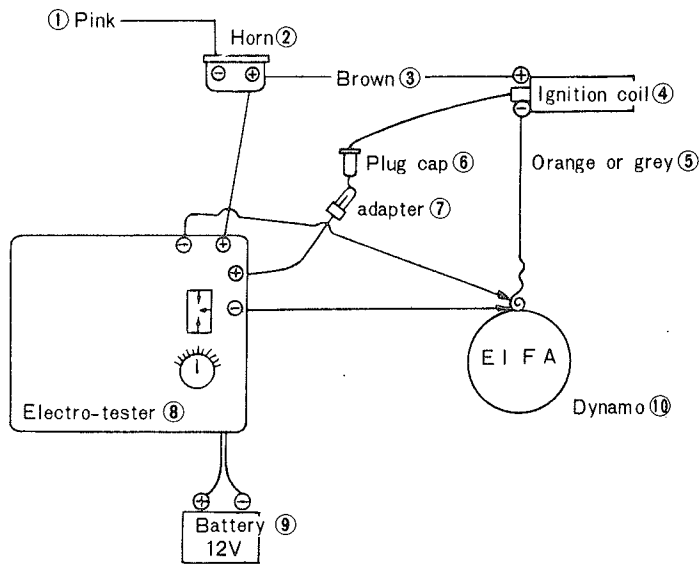

Disconnect the lead attached to the ignition dynamo terminal 1 and connect the negative primary and negative secondary leads of the tester to it.

Detach the high tension lead from the plug, attach an adapter (copper or iron wire) to the plug lead cap, and connect this adapter lead to the positive secondary lead of the tester.

Connect the positive primary lead of the tester to the brown lead terminal of the horn.

Use a 12V battery as power source for the tester.

If the tester shows a spark of 7 mm or more, the coil is in good condition.

7-11 Checking the Main Switch (removed from the chassis)

Key "Off" position

B/W B

Key "I" position

R Br

G W

Key "II" position

R Br

R L

Br L

W Gr

LW Y

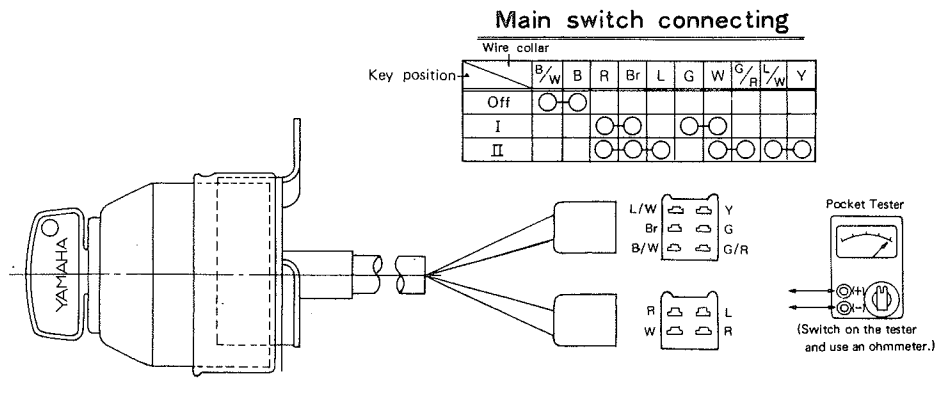

If the readings or the above eight measurements are nearly 0Ω , and no short-circuit is noticed between the terminals, as well as between the lead terminal and the switch body, the main switch is in good condition.

CHAPTER 8. ELECTRICAL SYSTEM FOR CT SERIES

8-1 Description

The CT series employ a flywheel magneto for the ignition system.

8-2 Table of Component Parts

Parts	Manufacturer	Model & Type
Flywheel magneto Spark plug	Hitachi Ltd. NGK	F-130 B-8ES
Headlight Speedometer Tachometer Handlebar Switch	Koito Mfg. Nippon Seiki Nippon Seiki Asahi Denso	6V, 25W/25W Neutral pilot light 6V3W Meter light 6V3W Meter light 6V3W
Main switch Ignition coil Horn	Asahi Denso Hitachi Ltd. Nikko Kinzoku	CM61-50 MF-6
Battery Rectifier Fuse	Nippon Battery Mitsubishi Elec. Osachi Mfg.	MV1-6D DS10HJ 10A x 2
Stop switch Taillight Flasher light	Asahi Denso. TAIKO Mfg.	6V, 23W/7W (6V, 17W/5.3W on CT1-C) 6V, 23W

8-3 Connection Diagram

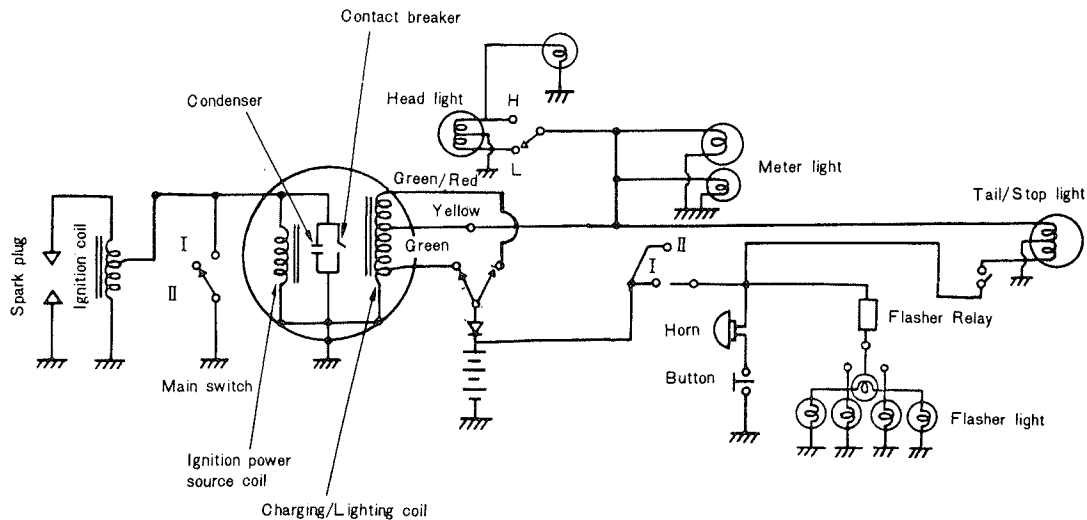

8-4 Ignition System—Function and Service

1. Function

The ignition system consists of the components. As the flywheel rotates, the contact breaker points begin to open and close, alternately. This make-and-break operation develops an electromotive force in the ignition power source coil, and produces a voltage in the ignition coil primary windings. The ignition coil is a kind of transformer, with a 1:50 turn ratio of the primary to the secondary winding. The voltage (150-300 V) which is produced in the primary coil, is stepped up to 12,000-14,000 V by mutual-induction and the electric spark jumps across the spark plug electrodes.

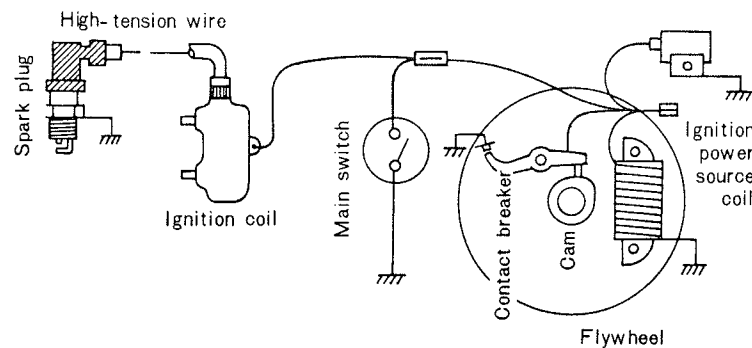

8-5 Ignition Timing

Remove the spark plug and screw the dial indicator holder into the plug hole. Next, insert the dial indicator into the holder. Bring the piston up to T.D.C. and set the zero on the dial face to line up exactly with the dial indicator needle. The crankshaft should then be turned backwards, so that the piston travels down past 2.5mm B.T.D.C. and slowly brought back up to precisely 2.0mm B.T.D.C. (This removes any slack in the gears). Adjust the points so that they are just beginning to open with the piston in this position. A low resistance point checker (100 Ohms or less) should be used to determine the opening and closing of the ignition points.

Ignition Timing, 2.0mm. B.T.D.C.

Maximum ignition point gap 0.3 to 0.4 mm. (0.012"-0.015")

8-6 Ignition Coil

Primary coil resistance value $4.9\Omega \pm 10\%$ (20°C or 68°F)

Secondary coil resistance value $.11\text{ K}\Omega \pm 10\%$ (20°C or 68°F)

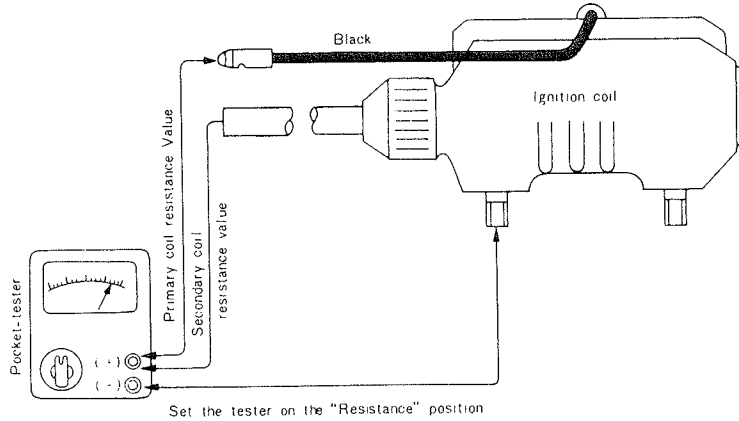

Note: When measuring the secondary coil resistance value, disconnect the plug cap. Otherwise, the resistance of the $5\text{K}\Omega$ noise suppressor incorporated in the plug will be added to the tester reading.

Spark Test:

Remove the spark plug from the cylinder head and reconnect the high voltage lead. Then hold the spark plug approximately 7 mm away from the head and see if it sparks as you crank the kickstarter. If it sparks at 7 mm, or so, and has blue white color, the ignition coil should be considered to be in good condition.

8-7 Condenser

The condenser instantly stores a static electric charge as the contact breaker points separate, and the energy stored in the condenser discharges instantly when the points are closed. If it were not for the condenser, an electric arc would jump across the separating contact points, causing them to burn.

Burned contact points greatly affect the flow of current in the primary winding of the ignition coil.

If the contact points show excessive wear, or the spark is weak (the ignition coil is in good condition), check the condenser.

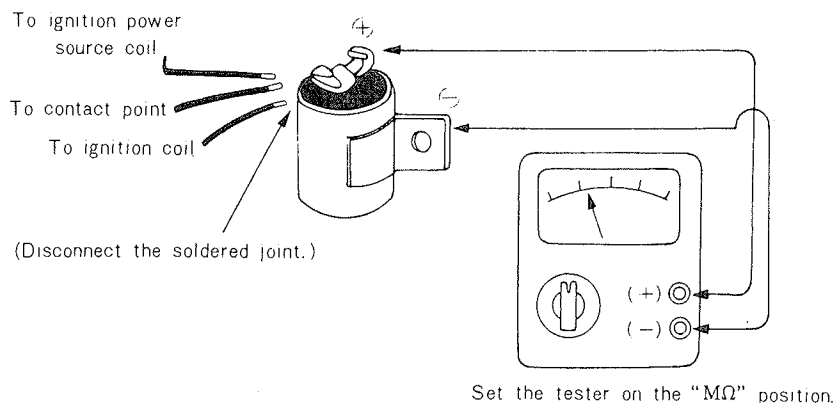

Insulation resistance tests should be conducted by connecting the tester. If the pointer swings fully and the reading is more than $3M\Omega$, the insulation is in good condition. If the insulation is faulty, the pointer will stay pointing at the uppermost reading, indicating very little resistance.

Note: After this measurement, the condenser should be discharged by connecting the positive and negative sides with a thick wire.

Capacity tests can be performed by simply setting the tester to the condenser capacity. The tester should be connected with the condenser in the same way as in the case of the insulation resistance test. Before this measurement, be sure to set the tester correctly.

If the reading is within $0.30 \mu F \pm 10\%$, the condenser capacity is correct.

8-8 Charging System

The charging system consists of the flywheel magneto (charging and lighting coils), rectifier, and battery.

1. Flywheel Magneto

As the flywheel rotates, an alternating current is generated in the charging and, lighting coils and converted to a half-wave current by means of a silicon rectifier.

This half-wave current charges the battery.

Charging Capacity (Daytime)

Green lead: Charging begins at 2,000 r.p.m.

4.5 A or less at 8,000 r.p.m.

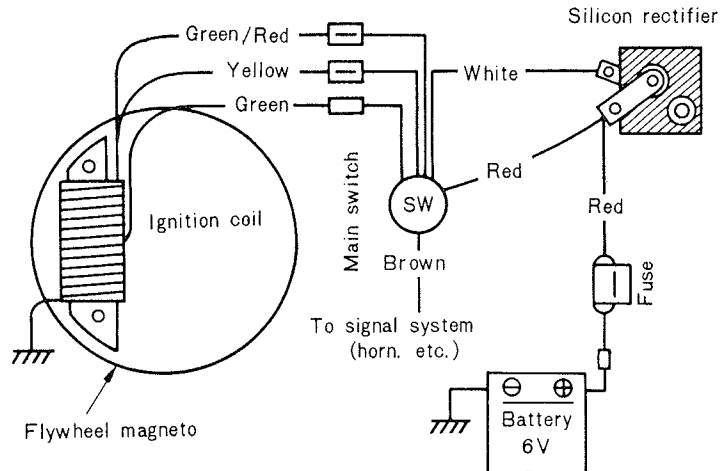

Lighting Capacity (Night time)

(With normal loads and normal wiring.)

5.7 V or more at 2,500 r.p.m.

8.5 V or less at 8,000 r.p.m.

- * The charging and lighting capacity is obtained when the battery is fully charged. If the battery is in a low state of charge and low in voltage, the charging rate will be not exactly the same as above. However, it is desirable that the figures are as close as possible.

2. Silicon Rectifier

The alternating current, which is generated by the flywheel magneto, is rectified and charged to the battery. For this rectification, a single-phase half-wave silicon rectifier is employed.

Characteristics: Rated output—4A,
Rated peak inverse voltage 400 V.

Polarity:

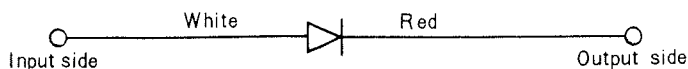

a. Checking the Silicon Rectifier

For measurements, an ohmmeter can be used.

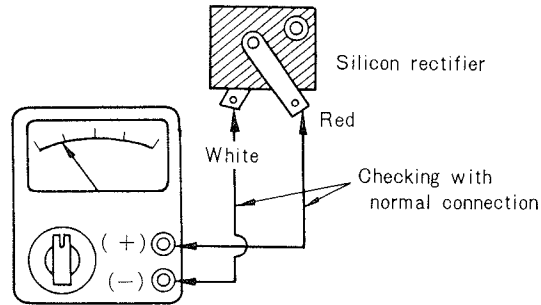

(Set the tester on "Resistance.")

Checking with Normal Connection

Connect the tester's red lead (+) to the silicon rectifier's red terminal, and connect the tester's black lead (-) to the rectifier's white terminal.

Standard value: 9–10 Ω

If the tester's pointer will not swing back over from the scale, the rectifier is defective.

Checking with Reversal Connection

Connect the tester the other way around.

Standard value: If the pointer will not swing, the rectifier is in good condition. If the pointer swings, the rectifier is faulty.

3. Operational Note

The silicon rectifier can be damaged if subjected to overcharging. Special care should be taken to avoid a short circuit and/or incorrect connection of the positive and negative leads at the battery. Never connect the rectifier directly to the battery to make a continuity check.

8–9 Battery

The battery is a 6 volt-4 AH unit that is the power source for the horn and stoplight. Because of the fluctuating charging rate due to the differences in engine R.P.M.s, the battery will lose its charge if the horn and stoplight are excessively used. The charging of the battery begins at about 3,000 R.P.M. Therefore, it is recommended to sustain engine R.P.M.s at about 3,000 to 4,000 R.P.M. to keep the battery charged properly. If the horn and stop-

light are used very often, the battery water should be checked regularly as continuous charging will dissipate the water. If the battery will not retain a charge (and the battery is in good condition) the White/Red wire of the flywheel magneto can be connected to the green wire of the wiring harness. This will increase the charging rate. But if the machine is ridden for long periods of time at high speeds with this wiring connection, the battery may be overcharged and damaged.

1. Checking

- 1) If sulfation occurs on plates due to lack of battery electrolyte, showing white accumulations, the battery should be replaced.
- 2) If the bottoms of the cells are filled with corrosive material falling off plates, the battery should be replaced.
- 3) If the battery shows the following defects, it should be replaced.

- The voltage will not rise to a specific value even after long hours charging.

- No gassing occurs in any cell.

The 6 V battery requires a charging current of more than 8.4 volts in order to supply a current at a rate of 1 amp. per hour for 10 hours.

2. Service Life

The service life of a battery is usually 2 to 3 years, but lack of care as described below will shorten the life of the battery.

- 1) Negligence in re-filling the battery with electrolyte.
- 2) Battery being left discharged.
- 3) Over-charging by rushing charge.
- 4) Freezing
- 5) Feeding of water or sulfuric acid containing impurities when re-filling the battery.

3. Storage

If any motorcycle is not used for a long time, remove the battery and have it stored by a battery service shop. The following instructions should be observed by shops equipped with chargers.

- 1) Recharge the battery.
- 2) Store the battery in a cool, dry place, and avoid temperatures below 0°C. (32°F)
- 3) Recharge the battery before mounting it on the motorcycle.

4. Service Standards

Battery: 6N4A-4D (Nippon Battery)

Battery spec.	6V-4AH
Electrolyte-Specific gravity and 1.25~1.27, 200 c.c. quantity	At full charge

5. Checking the Main Switch (removed from the chassis)

Key "O" position (Off)

B/W ↔ B

Switch body Key "I" position (for daytime)

R ↔ Br

G ↔ W

Key "II" position (for nighttime)

R ↔ Br

Br ↔ L

R ↔ L

W ↔ Gr

L/W ↔ Y

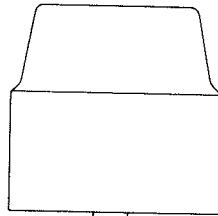

Connecting list

Wire Color / Position	B/W	B	R	Br	L	G	W	G/R	L/W	Y
OFF	○	○								
I			○	○		○	○			
II			○	○	○		○	○	○	○

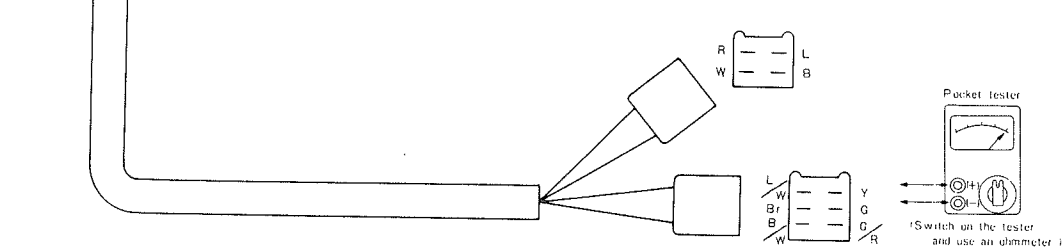

If the readings on the above 8 measurements are nearly 0 Ω, and no short-circuit is noticed between the terminals, as well as between the lead terminal and the switch body, the main switch is in good condition.

8-10 Spark Plug

The life of a plug and its discoloring vary, according to the habits of the rider. At each periodic inspection, replace burned or fouled plugs with suitable ones determined by the color and condition of the bad plugs. One machine may be ridden only in urban areas at low speeds, whereas another may be ridden for hours at high speeds, so confirm what the present plugs indicate by asking the rider how long and how fast he rides, and recommend a hot, standard, or cold plug accordingly. It is actually economical to install new plugs every 3,000 km (2,000 miles) since it will tend to keep the engine in good condition and prevent excessive fuel consumption.

1. How to "read" spark plug (condition)
 - a. Best When the porcelain around the center electrode is a light tan color.
 - b. If the electrodes and porcelain are black and some what oily, replace the plug with a hotter-type for low speed riding.
 - c. If the porcelain is burned white and/or the electrodes are partially burned away, replace the plug with a colder-type for high speed riding.

2. Inspection

Instruct the rider to:

Inspect and clean the spark plug at least once a month or every 1,000 km. (600 miles) Clean the electrodes of carbon and adjust the electrode gap to 0.5-0.6 mm. (0.023 in.) Be sure to use standard B-8ES plug as replacements to avoid any error in reach.

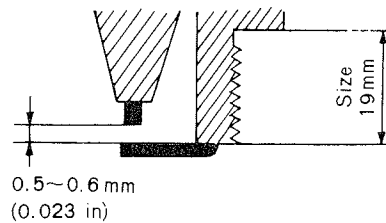

8-11 Lighting and Signal Systems

The lighting and signal systems consist of the horn and stoplight (power source-battery) and the headlight, taillight, meter lamps, flasher light, speedometer and tachometer (power source-flywheel magneto).

1. Headlight

The headlight has double 6V, 25W bulbs, and a 6V, 1.5W neutral pilot light on its top. A beam directing adjusting screw is fitted on the right side of the light rim so that the horizontal direction of the beam can be adjusted (not vertically).

2. Taillight and Stoplight

A 6V, 7W taillight and a 6V, 23W stoplight are mounted. The lens of the taillight is provided with reflectors on its three sides—rear, right and left.

3. Horn

The horn is a 6V, flat type, and has a tone-volume adjusting nut on its back.

After adjustment is made, apply paint or lacquer to the nut for water proofing purposes.

4. Speedometer

A circular type speedometer is mounted on the bracket. For illumination, a 6V, 3 W bulb is provided.

5. Tachometer

As in the case of the CT2 , the tachometer is separated from the speedometer.

The revolutions per minute (r.p.m.) of the crankshaft are carried from the primary drive gear to the tachometer drive gear in the crank case, and through the worm gear meshing with the drive gear to the tachometer cable. The light for illumination is of 6V,3W capacity

Note: Use bulbs of the correct capacity for the headlight, taillight, meterlight , flasher light and neutrallight which are directly connected to the flywheel magneto. If large capacity bulbs are used, the voltage will drop, giving a poor light. On the contrary, if smaller capacity bulbs are used, the voltage will rise, shortening the life of bulbs. Avoid the use of 12V bulb, because shorter service life will result.

When the headlight beam switch is operated to change the beam from one to another, the headlight is designed to keep both bulbs turned on, and the beam is changed. This is to protect other light bulbs – meterlight, taillight, etc., from burning out as a result of turning off the headlight, though temporarily. If one of these light bulbs burns out while the machine is running, it will put other bulbs under an overload condition, thus shortening their service life. In this case, it is necessary to reduce the engine speed and replace the burnt out bulb as quickly as possible.

LT2/LT3 100 Circuit Diagram

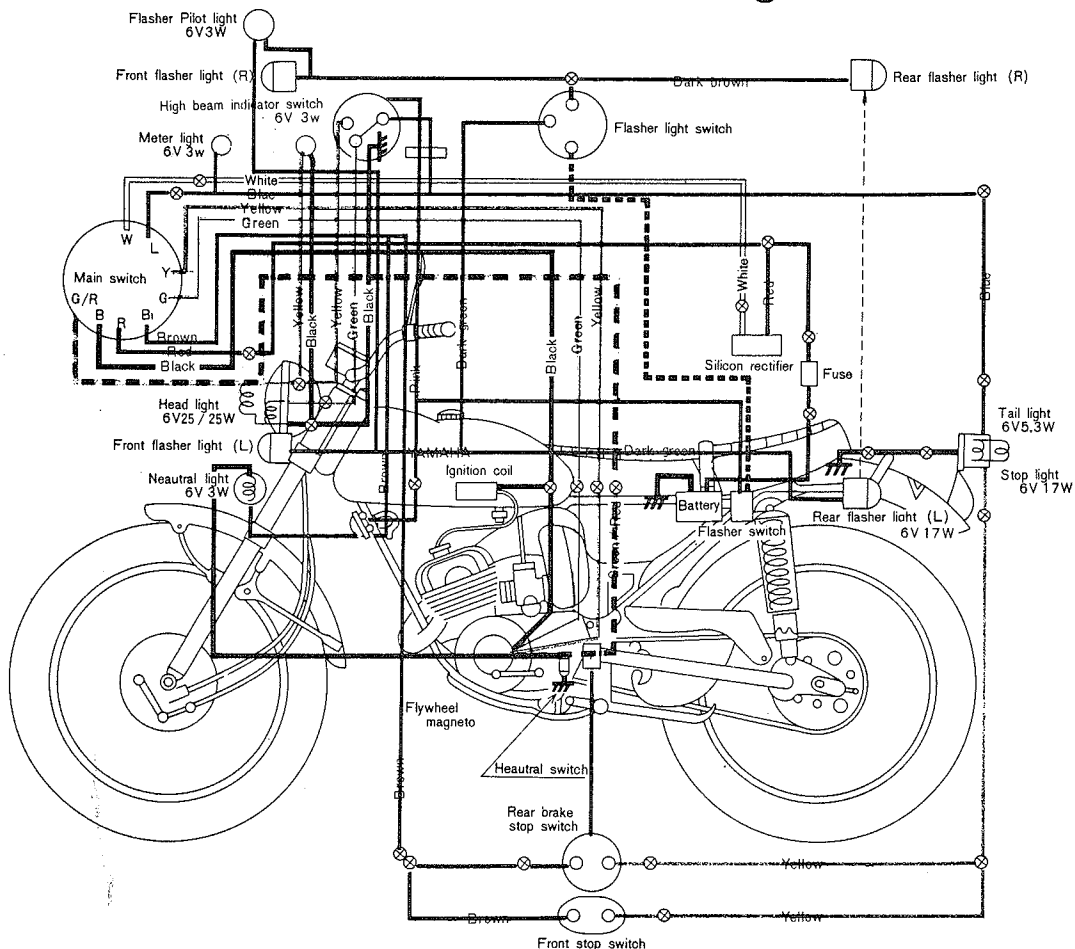

CONVERSION TABLES

CONVERSION TABLES

LENGTHS

Multiply	By to Obtain	Multiply	By to Obtain
Millimeters (mm)	0.03937 Inches	Kilometers (km)	0.6214 Miles
Inches (in)	25.4 Millimeters	Miles (mi)	1.609 Kilometers
Centimeters (cm)	0.3937 Inches	Meters (m)	3.281 Feet
Inches (in)	2.54 Centimeters	Feet (ft)	0.3048 Meters

WEIGHTS

Kilograms (kg)	2.205 Pounds	Grams (g)	0.03527 Ounces
Pounds (lbs)	0.4536 Kilograms	Ounces (oz)	28.35 Grams

VOLUMES

Cubic centimeters (cc)	0.061 Cubic inches	Imperial gallons	277.274 cu. in.
Cubic inches (cu. in)	16.387 c.c.	Liters (ℓ)	1.057 Quarts
Liters (ℓ)	0.264 Gallons	Quarts (qt)	0.946 Liters
Gallons (gal)	3.785 Liters	Cubic centimeters (cc)	0.0339 Fluid ounces
U. S. gallons	1.2 Imperial gals.	Fluid ounces (fl. oz.)	29.57 c.c.
Imperial gallons	4.537 Liters		

OTHERS

Metric horsepower (ps)	1.014 bhp.	Foot-pounds (ft-lbs)	0.1383 kg-m
Brake horsepower (bhp)	0.9859 ps.	Kilometers per liter (km/ℓ)	2.352 mpg
Kilogram-meter (kg-m)	7.235 ft-lb	Miles per gallon (mpg)	0.4252 km/ℓ

TORQUE CHART

Nut	Bolt	kg/m	Ft/lbs	In/lbs
13 mm	8 mm	2.0	15	180
14 mm
17 mm	10 mm	3.5-4.0	20-29	300-350
19 mm	12 mm	4.0-4.5	29-33	350-400
22 mm	14 mm	4.5-5.0	33-37	400-450
26 mm	17 mm	5.8-7.0	40-50	500-600
27 mm	18 mm	5.8-7.0	40-50	500-600
30 mm	20 mm	7.0-8.3	50-60	600-700
Spark Plug		2.7-2.9	19-20	230-250

AT1—C WIRING DIAGRAM

Chart of wire colors

Armature Circuit	white
Field Circuit	green
Earth Circuit	black
Common Circuit	brown
Battery (+) Circuit	red
Lamp Circuit	blue
Horn Circuit	pink
Neutral Lamp Circuit	sky blue
Tail Lamp Circuit	blue
Ignition Coil Circuit	orange
Stop Lamp Circuit	yellow
Starter Switch Circuit	blue-white
Starter Circuit	light green
Flasher Light (Right) Circuit	dark green
Flasher Light (Left) Circuit	dark green
Flasher Switch Circuit	brown-white

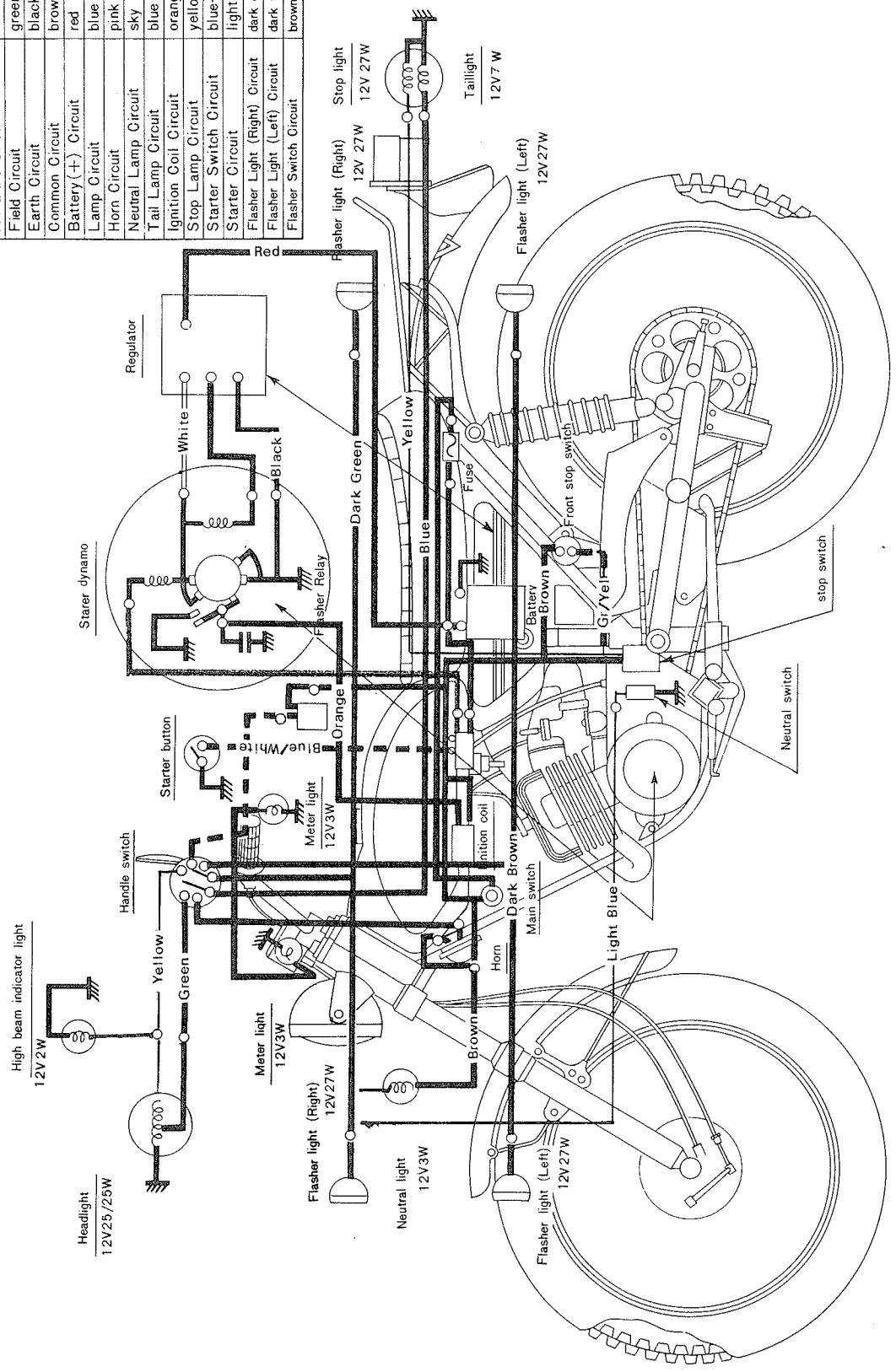

AT2 / AT3 WIRING DIAGRAM

Chart of wire colors

Armature Circuit	white
Field Circuit	green
Earth Circuit	black
Common Circuit	brown
Battery (+) Circuit	red
Lamp Circuit	blue
Horn Circuit	pink
Neutral Lamp Circuit	sky blue
Tail Lamp Circuit	blue
Ignition Coil Circuit	orange
Stop Lamp Circuit	yellow
Starter Switch Circuit	blue-white
Starter Circuit	light green
Flasher Light (Right) Circuit	dark green
Flasher Light (Left) Circuit	dark brown
Flasher Switch Circuit	brown-white

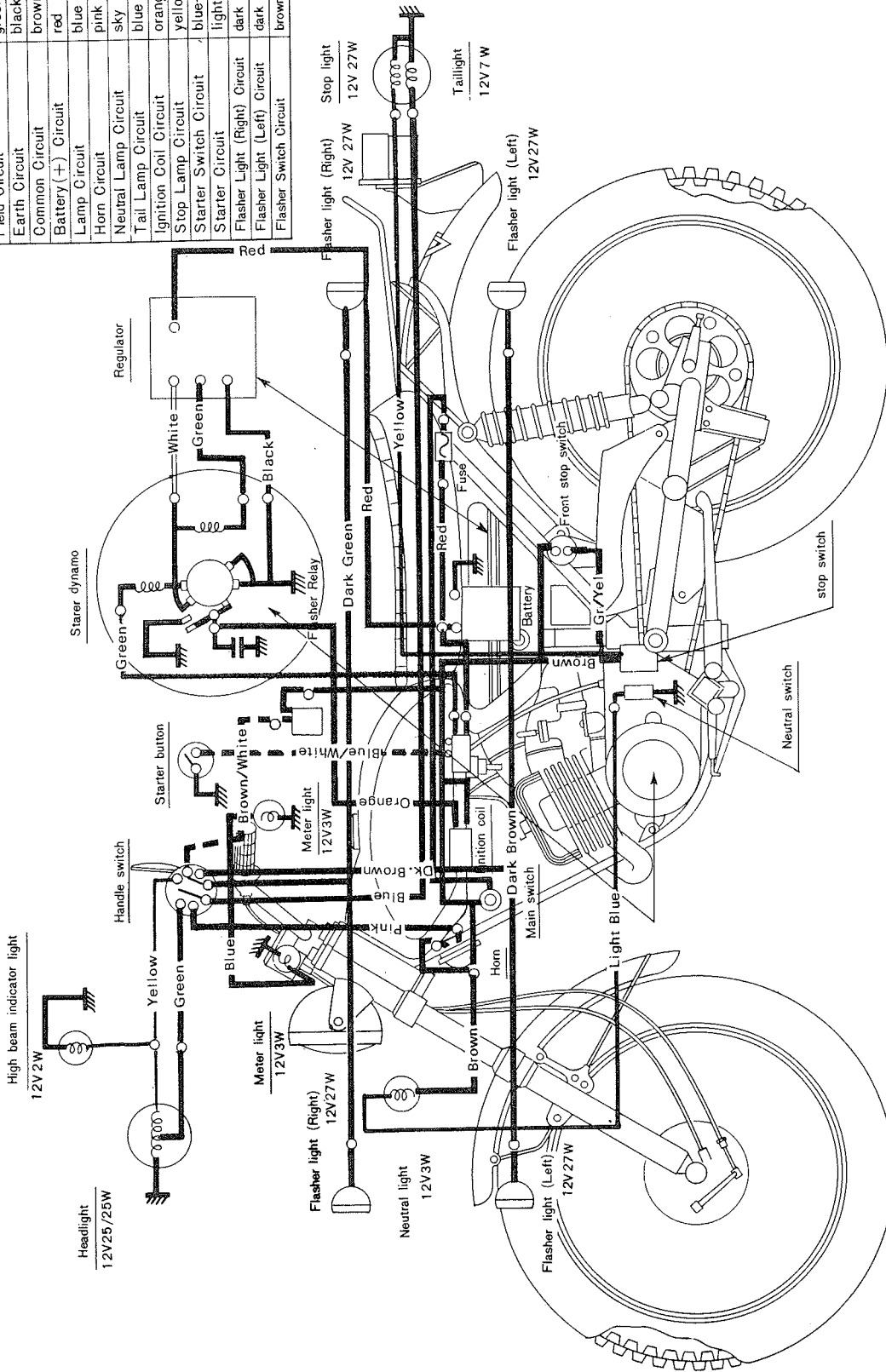

CT1-C WIRING DIAGRAM

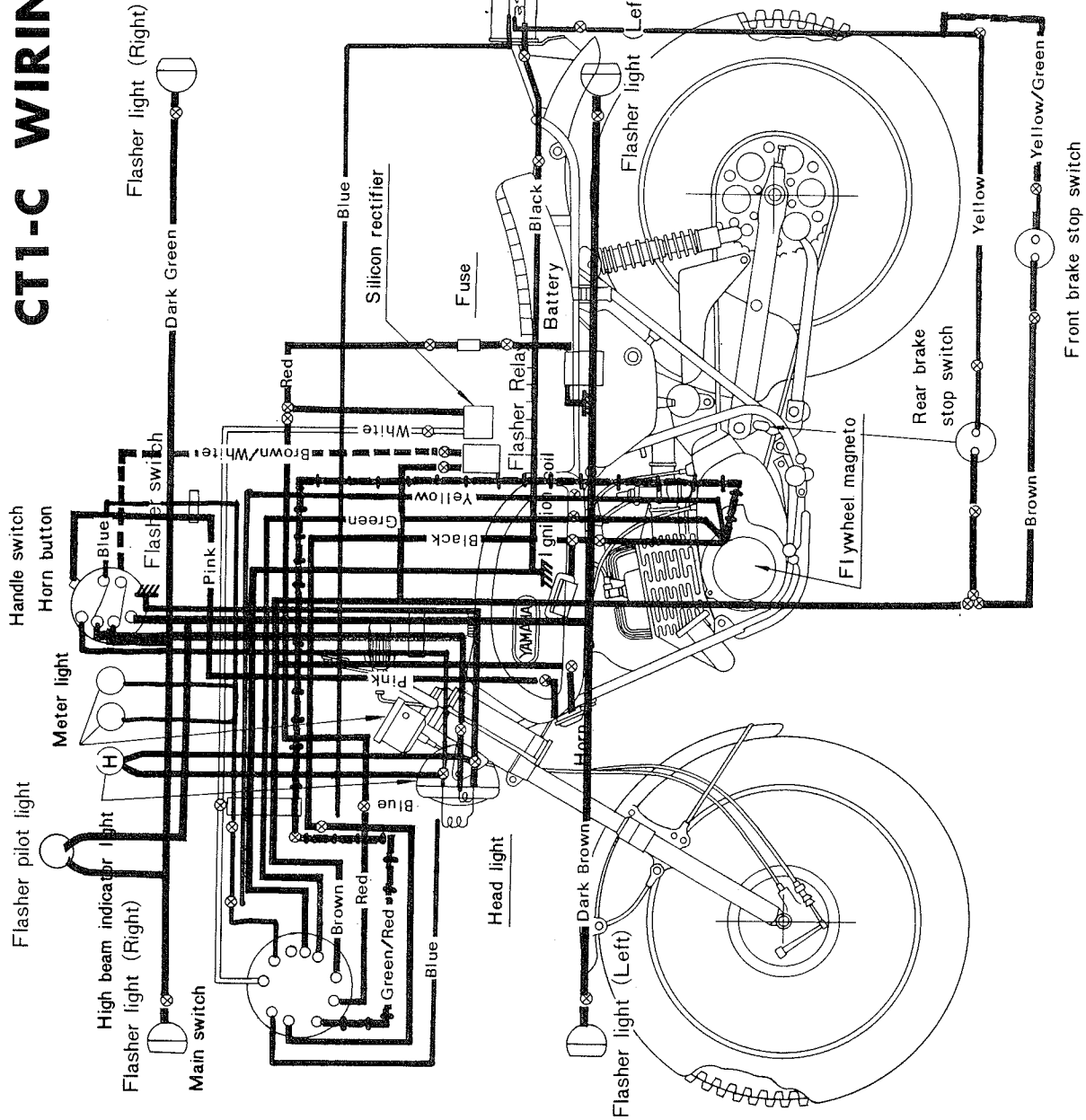

Color	E	B	R	Br	L	G	W	GR	LW	Y
Position	OFF	○								
I			○	○	○	○				
II			○	○	○	○				

Chart of wire colors

Daytime charging circuit	Green
Night time charging circuit	Green/Red
Battery (+) circuit	Red
Ground circuit	Black
Front brake stop light circuit	Green/Yellow
Rear brake stop light circuit	Yellow
Tail light circuit	Blue
Head/Meter light circuit	Blue (L,W)
Common circuit	Brown
Head light main circuit	Yellow
Head light sub circuit	Green
Horn circuit	Pink
Rectifier circuit	White
Flasher circuit	Brown/White
Flasher light (R) circuit	Dark Green
Flasher light (L) circuit	Dark Brown

CT2 / CT3 WIRING DIAGRAM

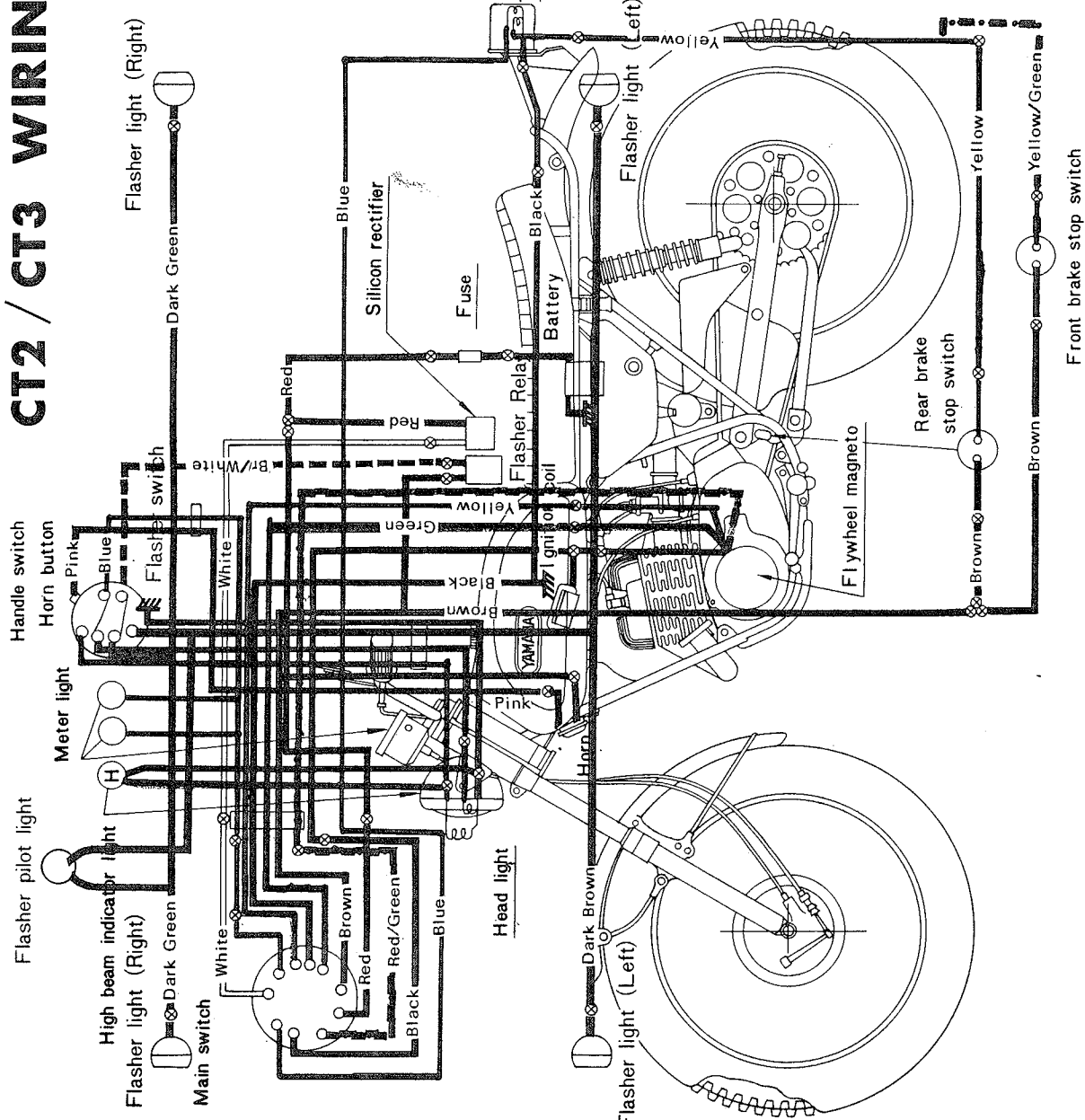

Color Position	E	B	R	Br	L	G	W	GRL	W	Y
OFF	○	○								
I		○	○	○	○					
II			○	○	○					

Chart of wire colors

Daytime charging circuit	Green
Night time charging circuit	Green/Red
Battery (+) circuit	Red
Ground circuit	Black
Front brake stop light circuit	Green/Yellow
Rear brake stop light circuit	Yellow
Tail light circuit	Blue
Head/Meter light circuit	Blue(L,W)
Common circuit	Brown
Head light main circuit	Yellow
Head light sub circuit	Green
Horn circuit	Pink
Rectifier circuit	White
Flasher circuit	Brown/White
Flasher light (R) circuit	Dark Green
Flasher light (L) circuit	Dark Brown

MISCELLANEOUS BULLETINS AND INSTRUCTIONS -

The following bulletins are correct as of the time of printing and are included as a guide to preventive maintenance procedures, etc. However, the procedures, parts, and other information contained within is subject to change at any time.

MOTORCYCLE PARTS NEWS

YAMAHA INTERNATIONAL CORPORATION
BUENA PARK, CALIFORNIA 90620
DATE 3/18/72

NUMBER 324
PAGE 1 of 1

LT2/LT2-M PRIMARY CRANKCASE SEAL RETAINER

We now have a retainer, P/N ACC-11110-01-00, in stock for the LT2 and LT2-M right hand crankcase seal.

There have been some instances where this seal has blown out, due to backfiring and resultant excessive crankcase pressure. Future production models will have an improved right hand crankcase with a circlip to keep this seal in place.

For current models, the retainer should be installed whenever a seal problem arises. Installation involves removal of the primary cover, placing the retainer over the seal, around the primary drive gear distance collar, and securing the retainer to the crankcase separating tool mounting holes with two 8 x 10mm pan head screws and lock washers.

DESCRIPTION	PART NUMBER	PRICE	DISC.	QTY.
PAN HEAD SCREW	92501-08010			2
SPRING WASHER	92903-08100			2
SEAL RETAINER	ACC-11110-01-00			1

WARRANTY:

The Seal retainer may be installed on any LT2/LT2-M as a preventive maintenance procedure. No warranty allowance will be given if the retainer is installed as a preventive measure only.

However, the retainer must be installed on any machine in which the seal fails per above. Parts and labor costs will be reimbursed per standard warranty procedure. Use job code #2008 at 1.2 hours.

#

MOTORCYCLE PARTS NEWS

YAMAHA INTERNATIONAL CORPORATION
BUENA PARK, CALIFORNIA 90620
DATE 3/15/72

NUMBER 325
PAGE 1 of 1

HT1, LT2, LT2-M OIL PUMP MODIFICATION

An improved oil pump assembly, P/N 304-13101-01-00, is currently being installed on 100cc Enduro and MX models. It is also available as a replacement for oil pumps on HT1, early LT2, and LT2-M machines. The new pump (and associated worm shaft) will provide an increased metering capacity. On HT1 models and early LT2 (~003930) and LT2-M (~103850) models the worm shaft must be changed to match the new oil pump. Please change your HT1 and LT2/LT2-M Parts Lists to reflect the new parts available.

ORDERING INFORMATION

Description	Old Part Number	New Part Number
Oil Pump Assembly	276-13101-00-00	304-13101-01-00
Worm Shaft	214-13175-01-00	275-13175-00-00

IDENTIFICATION

The old pump is color-coded red and has a "C" stamp mark on the pulley: the new pump is color-coded blue, has a "C" stamp on the pulley and a white paint mark over the "C" on the pulley.

The gear pitch on the old worm shaft is 1.85mm; the gear pitch on the new worm shaft is 2.5mm.

SERVICE NOTE: Minimum stroke and cable adjustments remain the same: minimum stroke - .008-.010"; cable - at mark at idle. Finally, all pumps, old and new, should always be checked to see that the guide pin does not contact the raised bosses on the cable pulley at idle or full throttle.

ENGINE NUMBER EFFECTIVITY

The new pump is stock on LT2's, E/N 003931 ~ and on LT2-M's, E/N 103851 ~

INTERCHANGEABILITY

The new pump and worm shaft are replaceable only as a set on machines equipped with the old pump and old worm shaft.

#

MOTORCYCLE PARTS NEWS

YAMAHA INTERNATIONAL CORPORATION
BUENA PARK, CALIFORNIA 90620

NUMBER
328

PAGE
1 of 2

DATE 5/30/72

LT2/M, AT2/M, CT2

CRANKCASE SEAL RETAINERS, Installation Procedure

Seal retainers for the right and left-hand crankcase seals on LT2, AT2, and CT2 models are now available from our Parts Department.

Installation of the right-hand retainer (P/N 304-15128-00) involves removal of the primary cover, placing the retainer over the seal, around the primary drive distance collar, and securing the retainer to the crankcase separating tool forward mounting hole with one 8 x 10mm hex head bolt or pan head screw and lock washer.

Installation of the left-hand retainer (P/N 304-15118-00) involves removal of the magneto flywheel and backing plate assembly. (On AT2 DC generator models, the stator assembly and armature must be removed.) Install the retainer using the two case securing screws shown in Fig. 1. Reinstall the magneto (or DC generator) assembly. Timing will change. Reset after.

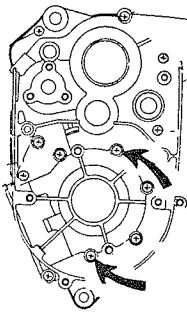

Fig. 1
Use arrow-indicated screws to attach left-hand retainer.

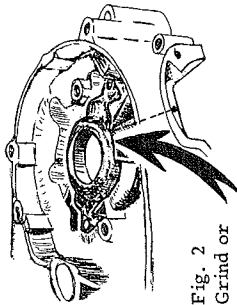

Fig. 2
Grind or bend retainer tab.

REF. NO.	DESCRIPTION	PART NUMBER	PRICE	DISC.	QTY.
LT2	AT2/CT2				
	HEX HEAD BOLT*	972-01080-10-00			1
	PAN HEAD SCREW*	925-01080-10-00			1
	SPRING WASHER	929-03081-00-00			1
3-25	R. H. SEAL RETAINER	304-15128-00-00			1
3-26	L. H. SEAL RETAINER	304-15118-00-00			1

*EITHER ONE MAY BE USED.

(Continued)

MOTORCYCLE PARTS NEWS

YAMAHA INTERNATIONAL CORPORATION
BUENA PARK, CALIFORNIA 90620

NUMBER
328

PAGE
2 of 2

DATE 5/30/72

LT2/M, AT2/M, CT2

CRANKCASE SEAL RETAINERS, Installation Procedure (cont'd.)

NOTE:

Seal retainer, P/N ACC-11110-01-00, (PNB #324) will be discontinued as soon as present supply is exhausted.

WARRANTY:

The seal retainer may be installed on any of the above machines as a preventive maintenance procedure. No warranty allowance will be given if the retainer is installed as a preventive measure only. However, the retainer must be installed on any machine in which a seal fails. If seal failure occurs while machine is under warranty, Parts and Labor costs will be reimbursed per standard warranty procedure. For:

Right-hand Seal - Use job code #2008 at 1.2 hours.

Left-hand Seal - Use job code #2010 at 1.2 hours.

RIGHT
(304-15128-00-00)
Use 8 x 10mm bolt or screw,
with lock washer.

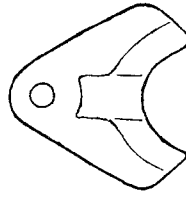

LEFT
(304-15118-00-00)
Use existing case securing
screws.

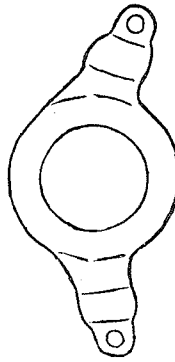

PARTS DEPARTMENT: Please update your Parts Lists accordingly.

#

MOTORCYCLE PARTS NEWS

YAMAHA INTERNATIONAL CORPORATION
BUENA PARK, CALIFORNIA 90620

DATE 7/3/72

NUMBER
348

PAGE
1 of 1

AT/CT Series SPEEDOMETER GEAR SET, 21" Wheel

Speedometer drive and driven gears are now available for AT/CT series machines which have been modified with a 21" front wheel and 2.75 x 21 tire. Both drive and driven gears must be changed as a set.

SPEEDOMETER GEAR RATIOS

MODEL	FRONT WHEEL SIZE	STANDARD GEAR RATIO	NEW RATIO FOR 21" WHEEL
AT1, -B, -C, -MIX	18"	27/10 = 2.700	30/10 = 3.000
CT1, -B, -C	19"	26/9 = 2.888	
AT2			
CT2			

PARTS ORDERING

New Parts Number	New Parts Name	Qty.
248-25135-10-00	GEAR, Drive	1
248-25138-10-00	GEAR, Meter	1

NOTE: These gears cannot be used for DT1/RT1 machines because the front axle is too large.

Please add the above data to your AT1/CT1 and AT2/CT2 Parts Lists.

#

MOTORCYCLE PARTS NEWS

YAMAHA INTERNATIONAL CORPORATION
BUENA PARK, CALIFORNIA 90620

DATE 4/5/73

NUMBER
367

PAGE
1 of 1

AT/CT (69-73) MISCELLANEOUS CARBURETOR COMPONENT PART NUMBERS

Please transfer the appropriate information within this bulletin to your 1973 AT3/CT3 Parts List. The additional information may be kept on file for quick reference.

MAIN JET	
No. 150	137-14143-30-00 AT1/CT1
No. 190	137-14143-38-00 ALL ATMX's
No. 230*	137-14143-46-00* AT2-3/CT2-3
NEEDLE JET	
N-8	248-14141-28-00 AT1/CT1
O-2	261-14141-32-00 AT2M/ATMX
O-6	304-14141-36-00 AT1M
	AT2-3/CT2-3
JET NEEDLE	
4D3-3	156-14116-03-00 AT1/CT1
4F15-2	152-14116-15-00 AT1M
4F15-3	152-14116-15-00 AT2M/ATMX
4J13-2*	166-14116-13-00* CT2-3
5J3-3*	316-14116-03-00* AT2-3
THROTTLE VALVE (Slide)	
C.A. 1.5	204-14112-15-00 AT1M
C.A. 2.0	204-14112-20-00 AT1/CT1
C.A. 2.0	314-14112-20-00 CT2-3
C.A. 2.5	204-14112-25-00 AT2M/ATMX
C.A. 2.5*†	(204-14112-25-00†) AT2-3
PILOT JET	
30	193-14142-30-00 AT1/CT1/AT1M
35	260-14142-35-00‡ AT2-3
25	260-14142-25-00‡ CT2-3
60	193-14142-60-00 AT2M/ATMX

* = See also, M/C SNB No. 308.

† = No. 2.5 Cut Away not in stock for 316 Carbs. 204 type (AT1) may be substituted.

NOTE: 314 & 316 type carburetors have angled idle speed adjust screw. If 314 type slide interchanged to earlier carb, mating idle speed screw and spring must also be used (see Parts List).

‡ = Type 260 & 193 pilot jets are completely different and not interchangeable.

MOTORCYCLE PARTS NEWS

YAMAHA INTERNATIONAL CORPORATION
BUENA PARK, CALIFORNIA 90620

DATE 6/1/72

NUMBER
336

PAGE
1 of 1

ALL HT1's/LT2's/AT2's/CT2's RIGHT CRANKCASE & DRIVE AXLE BRNG., Dimension Change

The Factory has increased the O. D. of the drive axle needle bearing (clutch side) for increased strength and reliability. The change will eventually affect all 90cc and 100cc Enduros, all AT2's and all CT2's.

AFFECTED MACHINES

At this time we have no firm E/N on production changes.

PARTS ORDERING INFORMATION

Please make the following corrections to all appropriate model Parts Lists:

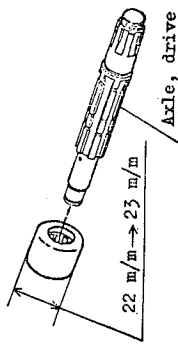

NOTE: There is no change in drive axles.

ALL HT's/LT's

Ref. No.	Old Parts No.	New Parts No.	Parts Name	Q'ty	Interchangeable
1-2	*276-15121-01	276-15121-02	*Case, crank right	1	Yes with Bearing
5-9	93315-31502	-----	Bearing	2 → 1	(Main Axle)
5-33	-----	93311-31507	Bearing	1	(Drive axle)

ALL AT2's/CT2's

Ref. No.	Old Parts No.	New Parts No.	Parts Name	Q'ty	Interchangeable
1-2	*315-15121-00	315-15121-01	*Case, crank right	1	Yes with Bearing
5-8	93315-31502	-----	Bearing	2 → 1	(Main Axle)
5-32	-----	93311-31507	Bearing	1	(Drive Axle)

NOTE: Items marked (*) : When old type runs out of stock, only the new type will be sold.

Bearings: Both the old and new types will be sold.

SERVICE NOTE: Due to the unavailability of a complete engine number list, the bearing O. D. must be measured prior to ordering replacement.

PLEASE BRING YOUR PARTS LISTS UP TO DATE

MOTORCYCLE PARTS NEWS

YAMAHA INTERNATIONAL CORPORATION
BUENA PARK, CALIFORNIA 90620

DATE 8/28/72

NUMBER
345

PAGE
1 of 1

AT2/CT2 KICK STARTER ASSEMBLY MODIFICATION

The Kick Starter Assembly has been modified to increase its strength. See drawing below for detailed changes. The new Kick Axle Assembly, Kick Gear, and Kick Clip are not interchangeable with the old types. They must be used as a set. See M/C SNB #295 for additional information.

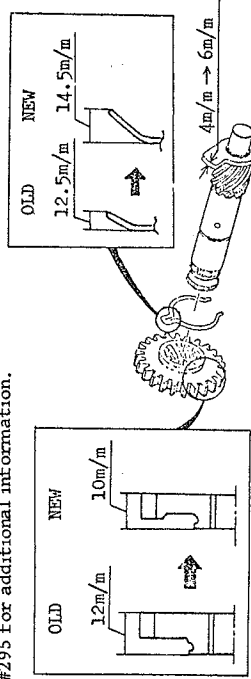

PARTS ORDERING INFORMATION:

Ref. No.	Old Part No.	New Part No.	Part Name	Qty.	Interchangeable
8-0-2	-----	315-15640-01-00	Kick Starter Assy.	1	Yes
8-8	315-15660-00-00	315-15660-01-00	Kick Axle Assy.	1	} As a Set
8-16	261-15641-00-00	315-15641-00-00	Gear, Kick	1	
8-17	251-15687-00-00	315-15687-00-00	Clip, Kick	1	

AFFECTED MACHINES: CT2 Engine/Frame No. 095481~.

AT2 Engine/Frame No. not available at this time.

SALE OF PARTS:

Kick Starter Assembly will be available as a new assembly. Kick Axle Assembly, Kick Gear, and Kick Clip - - both the old and new types will be sold.

PLEASE BRING YOUR PARTS LISTS UP TO DATE

#

MOTORCYCLE SERVICE NEWS

YAMAHA INTERNATIONAL CORPORATION
BUENA PARK, CALIFORNIA 90620

DATE 7/1/71

NUMBER
276

PAGE
1 of 1

ENDUROS CLOSE-RATIO MODELS (CTIC, DTLE, RTLB)

Due to the increased demand for close-ratio transmissions, the factory has released a limited number of the above models with close-ratio "MX" transmissions already installed.

*THESE MACHINES ARE IDENTICAL IN ALL OTHER RESPECTS TO CURRENT MODELS. In consideration of this fact, machines will be shipped without regard to type, and warranty procedure is unchanged.

MODEL IDENTIFICATION

To aid in identification, the close-ratio models have a different engine number sequence than current machines. Please acquaint your personnel with this identification method so that proper parts replacement can be made in the event of future servicing.

<u>CLOSE-RATIO MODEL</u>	<u>*STARTING NUMBER</u>	<u>**STANDARD MODEL STARTING NUMBER</u>
CTIC	CT1-200101	-032101
DTLE	DT1F-00101	-20101
RTLB	RT1-73101	-53101

*NOTE: Starting sequence (first two digits) underlined.
**NOTE: M/C SNB #248 gives complete list of standard models.

* * * * *

*SPECIAL NOTE: The close-ratio CTIC comes equipped with a secondary gear ratio of 16/37 (2.313:1) in order to provide approximately the same overall gearing as the standard model.

#####

MOTORCYCLE SERVICE NEWS

YAMAHA INTERNATIONAL CORPORATION
BUENA PARK, CALIFORNIA 90620

DATE 12/7/71

NUMBER
287

PAGE
1 of 1

LT2 & LT2-M

TRANSMISSION, Main Axle Bearing Installation

The main axle bearing (P/N 933-06303-04-00) has a steel seal on one side which is designed to maintain the correct oil level in the transmission. When replacing this bearing it is mandatory that the side of the bearing having the steel seal face the right-hand or clutch side of the right crankcase half. See illustration below.

Improper installation of this bearing will prevent transmission oil from lubricating the bearing and result in its failure.

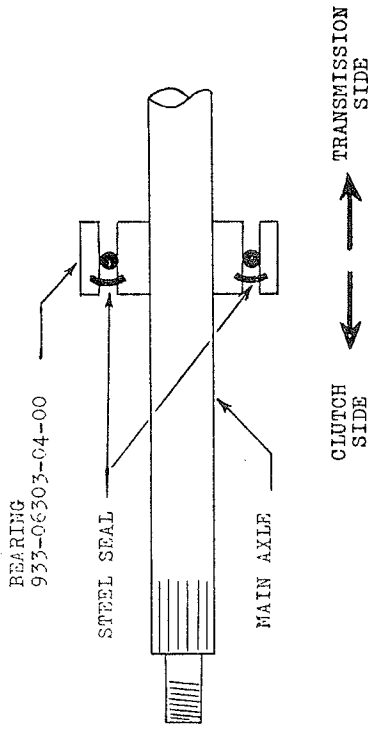

MOTORCYCLE SERVICE NEWS

YAMAHA INTERNATIONAL CORPORATION
BUENA PARK, CALIFORNIA 90620

DATE 3/26/72

LT2, AT2, CT2, DT2, & RT2 GAS CAP BREATHER ASSEMBLY

NUMBER
289

PAGE
1 of 2

MOTORCYCLE SERVICE NEWS

YAMAHA INTERNATIONAL CORPORATION
BUENA PARK, CALIFORNIA 90620

DATE 3/26/72

LT2, AT2, CT2, DT2, & RT2 GAS CAP BREATHER ASSEMBLY (cont'd.)

ASSEMBLY PROCEDURE:

If you have a machine which appears to be suffering from lack of gasoline after a short engine run (even though the tank has gas in it), it may be caused by improper venting of the gas tank. Examine Gasket, cap 1 (P/N 308-24641-00-00) to see if it has a 1/16" vent hole approximately 5/32" from the outer edge. A few of these gaskets, without a vent hole, have been installed on new machines. This hole allows the gas tank to be vented to atmospheric pressure.

If a replacement gasket is not readily available, a suitable fix may be made by drilling a 1/16" hole in the old part. This hole must be drilled in the proper spot or proper venting may not be possible. The hole must be drilled 5/32" from the outer edge of the gasket and directly opposite (180°) from the middle node of the three locating nodes on the gasket. See drawing #1 below. For location of gasket, see drawing #2, Reference #5.

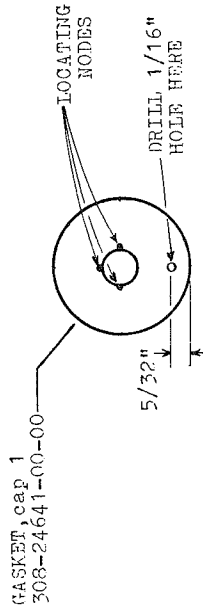

DRAWING 1

Extreme care must be used in reassembling the gas cap breather assembly. Assembly procedure is given on page 2.

(continued)

1. Insert rubber gasket (4) in special washer (3).

2. Insert washer (3) and gasket (4) in gasket (5). Note: Notches in washer (3) must be aligned with protrusions on inside of rim of gasket (5), and flat end of gasket (4) fits in recess of gasket (5).

3. Insert gasket (5), washer (3), and gasket (4) in cup (6) with the three nodes on gasket (5) in corresponding notches in cup (6).

4. Place cap (2) over cup (6).

5. Install packing (7) over cap (2) and cup (6) with widest side of packing (7) on cup (6) side.

6. Center gasket (5) in assembly.

7. Install breather assembly and spring (1) on gas cap with washer (8) and circlip (9).

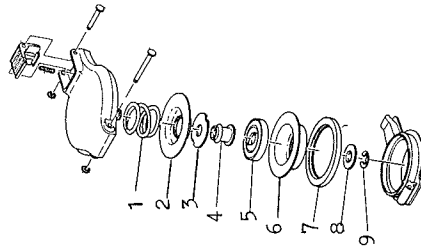

Drawing #2

PARTS INFORMATION

A complete breather assembly (P/N 308-00000-05-00), consisting of parts (2) through (7) (see drawing #2), is now available from the Parts Department.

Please add this information to your LT2, AT2/CT2, and DT2/RT2 Parts Lists.

#

MOTORCYCLE SERVICE NEWS

YAMAHA INTERNATIONAL CORPORATION
BUENA PARK, CALIFORNIA 90620

DATE 6/18/72

NUMBER
290

PAGE
1 of 2

ALL INSPECTION & COMPARISON OF SHIFT CAMS

When transmission gears fail to mesh properly or the transmission "jumps out" of gear, the trouble may be an improperly ground or excessively worn shift cam. If a preliminary inspection of the shift cam (and related parts) has failed to detect any obvious defects, the cam may be "foot-printed" or "cam-printed" for comparison with one or more new cams from your parts stock. The following is a step-by-step procedure for effectively "cam-printing" shift cams:

1. Thoroughly clean each shift cam to remove all oil residue.
2. Tape down a sheet of vellum or onion-skin translucent paper to a smooth level surface. Identify vellum with part number and condition (new or used) of shift cam to be "cam-printed" on that sheet.

Note: "Cam-prints" of new parts from stock should be filed for future reference.

3. Draw a straight line across the sheet of vellum about 2" from one end and mark it "Pin C/L". This will be a reference line indicating the pin centerline and will aid in aligning "cam-prints" when making subsequent comparisons.
4. Roll shift cam back and forth across an ink pad to thoroughly coat surfaces of shift cam with ink. Avoid touching inked surfaces. See Drawing #1.

5. Carefully place shift cam down on vellum with center of pin aligned with previously drawn "Pin C/L" reference line. Make sure that both ends of shift cam are centered over reference line.

6. Roll inked shift cam across vellum in one direction only. Apply even pressure on both ends of cam to avoid skidding cam on vellum. Practice rolls over common "Bond" typing paper may be required to achieve the proper rolling technique. See Drawing #2.

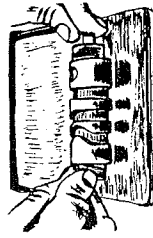

Dwg. 1

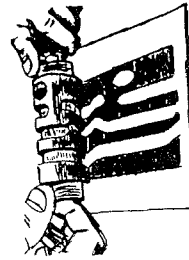

Dwg. 2

MOTORCYCLE SERVICE NEWS

YAMAHA INTERNATIONAL CORPORATION
BUENA PARK, CALIFORNIA 90620

DATE 6/18/72

NUMBER
290

PAGE
2 of 2

ALL INSPECTION & COMPARISON OF SHIFT CAMS (cont'd.)

7. Make a "cam print" for the suspect (used) shift cam and one or more new cams having identical part numbers.
8. After all "cam prints" are thoroughly dry, the two vellum sheets may be overlaid, with the "Pin C/L" reference lines aligned, and held up to the light for comparison. Any deviations between "cam-prints" indicates that the suspect (used) part may be defective and should be replaced. Comparison with more than one new shift cam is advised if parts are available.
9. Prior to "printing" the cam should be checked for the more common, obvious problems, such as:
 - a. Cam profile wear (from followers)
 - b. Cam lobe chipping and/or galling.
 - c. Any other damage which could be caused through malfunction of component parts.

Note: See M/C SNB's #259 & #277 for additional information
See M/C PNB #335 for additional information.

#

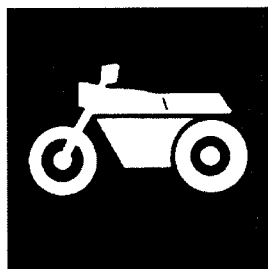

YAMAHA

GENUINE

PARTS CATALOGUE

MOTORCYCLE

CRANKCASE - CYLINDER

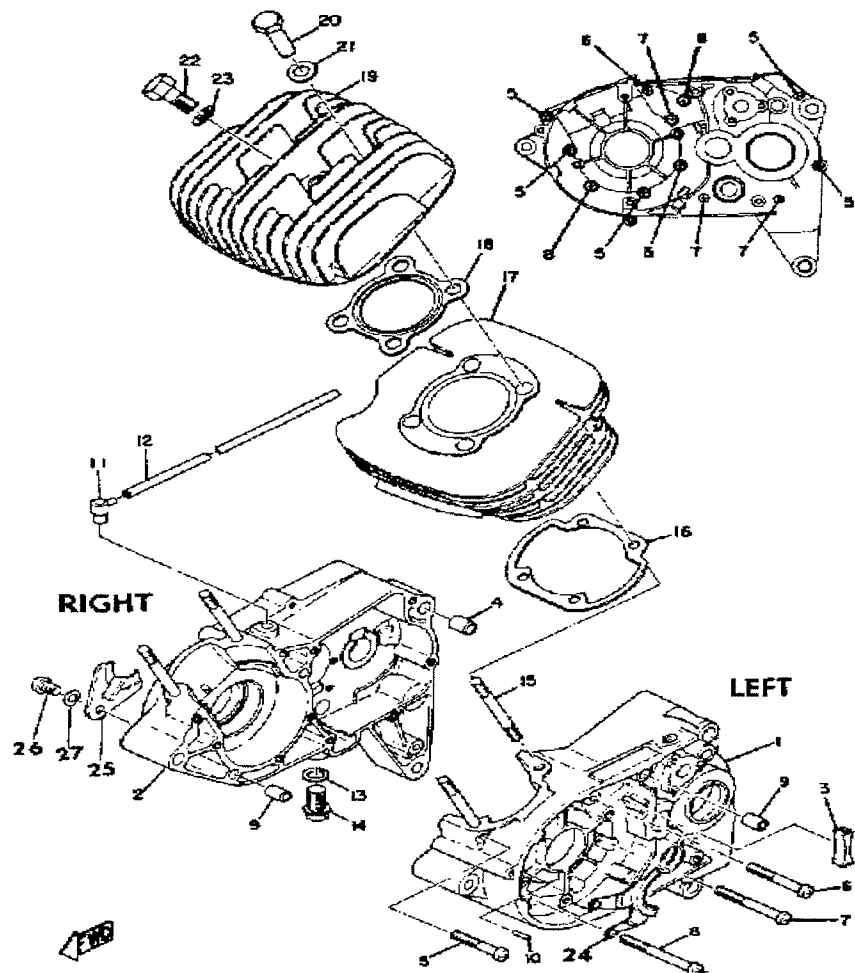

Ref. No.	Part Number	Description	Qty	Remarks
1	(248-15111-02-00)	CRANKCASE 1	1	
2	(444-15121-01-00)	CRANKCASE 2	1	
3	248-15357-00-00	GROMMET	1	
4	99530-14016-00	PIN, DOWEL	1	
5	98580-06545-00	SCREW PAN HEAD (92503-06045)	6	
6	98580-06055-00	SCREW, pan head (92501-06065-00)	2	
7	98580-06565-00	SCREW, PAN HEAD (92501-06065)	3	
8	92580-06560-00	SCREW PAN HEAD	1	
	98501-06070-00	SCREW, PAN HEAD	1	
9	99530-10014-00	PIN, DOWEL	3	
10	93603-14026-00	PIN, DOWEL	1	
11	583-15371-00-00	BREATHER	1	
12	(90446-07009-00)	HOSE	1	
13	90430-12207-00	GASKET	1	
14	90340-12005-00	PLUG, DRAIN	1	
15	90116-08064-00	BOLT, STUD	4	
16	248-11351-00-00	GASKET, CYLINDER	1	
17	(314-11311-02-00)	CYLINDER 1	1	
	(316-11311-02-00)	CYLINDER 1	1	
18	248-11181-00-00	GASKET, CYLINDER HEAD 1	1	
	251-11181-00-00	GASKET, CYLINDER HEAD 1	1	
19	(314-11111-01-94)	HEAD, CYLINDER 1	1	
	(316-11111-00-00)	HEAD, CYLINDER 1	1	
20	90179-08303-00	NUT	4	
21	90201-12362-00	WASHER, PLATE	4	
22	90340-14022-00	PLUG, STRAIGHT SCRW (214-11197-00)	1	

CONTINUED ON NEXT FRAME ►

CRANKCASE - CYLINDER

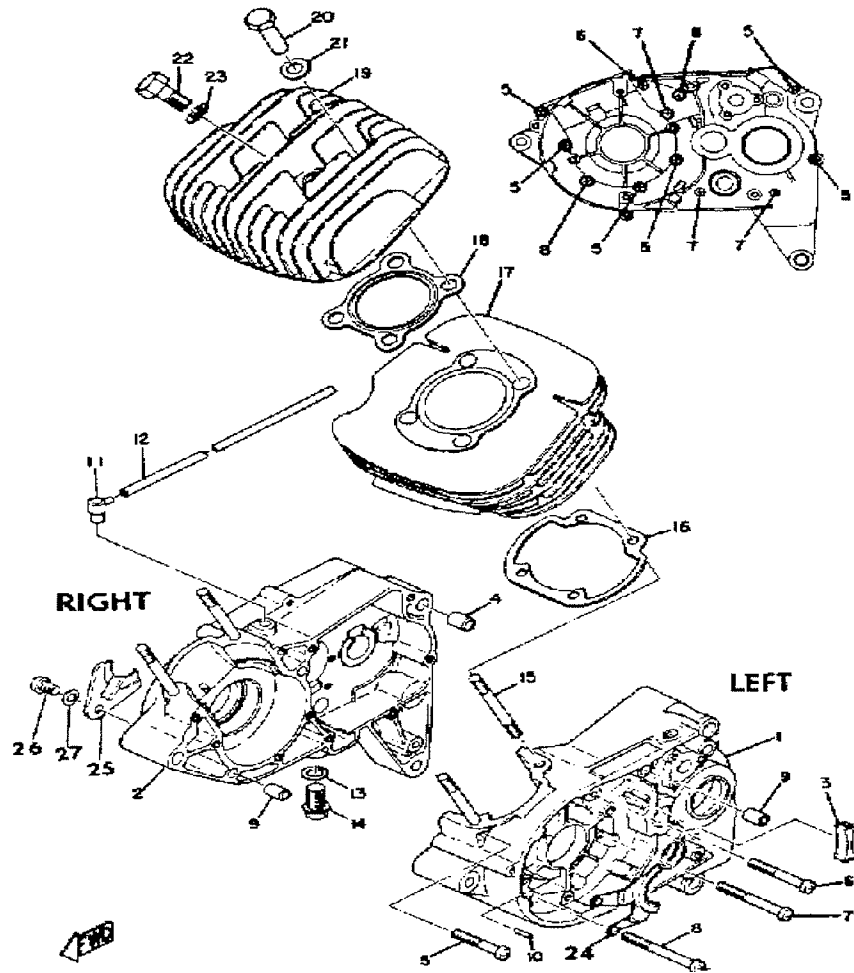

Ref. No.	Part Number	Description	Qty	Remarks
23	214-11198-01-00	GASKET	1	
24	(304-15118-00-00)	HOLDER	1	
25	304-15128-00-00	HOLDER	1	
26	92502-08016-00	SCREW, PAN HEAD 0 2	1	
27	92990-08100-00	WASHER	1	

CRANK - PISTON

Ref. No.	Part Number	Description	Qty	Remarks
1	(316-11412-60-00)	CRANK 1	1	
	(452-11412-00-00)	CRANK 1	1	
2	(248-11422-00-00)	CRANK 2	1	
3	3R2-11651-01-00	. ROD, CONNECTING	1	
4	3M5-11681-00-00	. PIN, CRANK 1	1	
5	93310-42277-00	. BEARING, CYLINDER.#10 (93310-42231)	1	
6	90209-22248-00	. WASHER	2	
7	314-11631-00-96	PISTON STD	1	
	314-11635-00-00	PISTON 1 O/S 0.5	1	ALT. PART
	314-11636-00-00	PISTON 2 O/S 0.0	1	ALT. PART
	316-11631-00-96	PISTON STD	1	
	316-11635-00-00	PISTON 1 O/S 0.5	1	ALT. PART
	316-11636-00-00	PISTON 2 O/S 0.0	1	ALT. PART
8	93310-216E1-00	BEARING	1	
	93310-216L2-00	BEARING, CYLINDRICAL	1	
9	137-11633-00-00	PIN, PISTON	1	
	251-11633-00-00	PIN, PISTON	1	
10	93450-17025-00	CIRCLIP	2	
11	314-11610-00-00	PISTON RINGSET STD	1	
	314-11610-10-00	PISTON RINGSET 1ST	1	
	314-11610-20-00	PISTON RINGSET 2ND	1	
	316-11610-00-00	PISTON RINGSET STD	1	
	316-11610-10-00	PISTON RINGSET 1ST	1	ALT. PART
	316-11610-20-00	PISTON RINGSET 2ND	1	ALT. PART
12	132-11561-00-03	SHIM, CRANK 1	1	
13	93306-20529-00	BEARING (B6205C4)	1	
14	93102-25061-00	OIL SEAL, SD-TYPE	1	
15	136-11561-00-03	SHIM, CRANK 1	1	U.R.

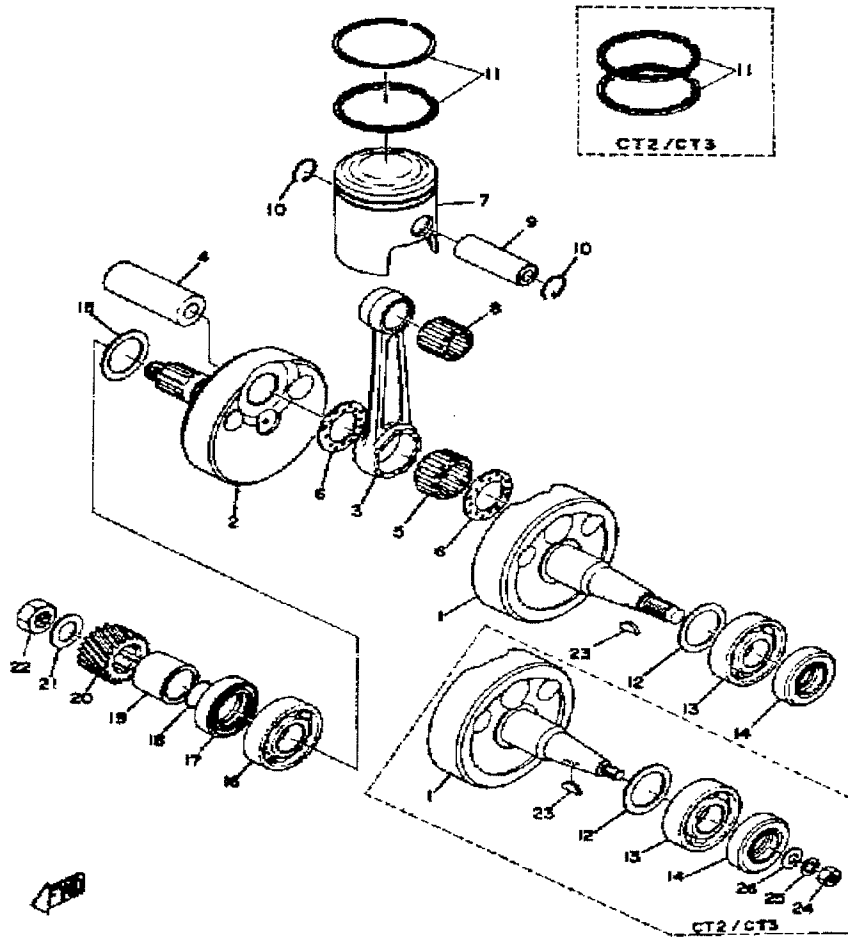

CONTINUED ON NEXT FRAME ►

CRANK - PISTON

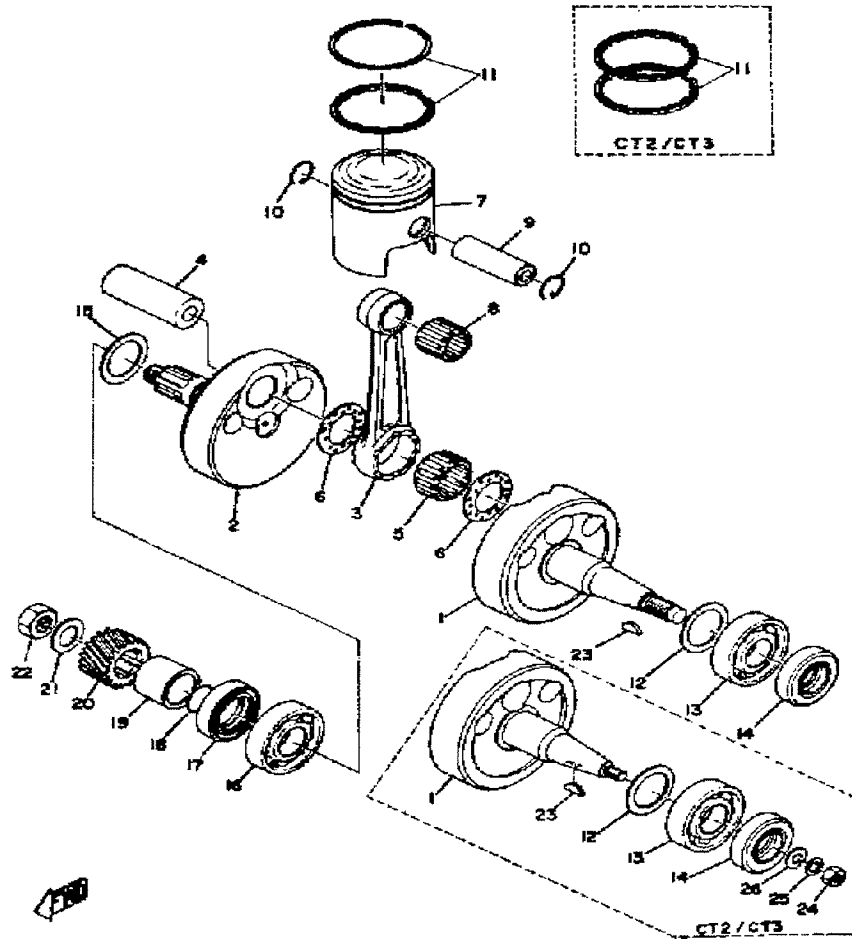

Ref. No.	Part Number	Description	Qty	Remarks
15	136-11561-00-04	SHIM, CRANK 1	1	U.R.
	136-11561-00-05	SHIM, CRANK 1	1	U.R.
	136-11561-00-06	SHIM, CRANK 1	1	U.R.
	136-11561-00-07	SHIM, CRANK 1	1	U.R.
16	93306-30421-00	BEARING (B6304C3)	1	
17	93103-28011-00	OIL SEAL	1	
18	93210-180A6-00	O-RING	1	
19	90387-205E9-00	COLLAR	1	
20	(248-16111-00-00)	GEAR, PRI DRIVE	1	
21	90208-12015-00	WASHER, CONICAL SPRING	1	
22	90170-12060-00	NUT	1	
23	90280-03017-00	KEY, WOODRUFF	1	
24	90170-12347-00	NUT, HEXAGON	1	
25	92901-12100-00	WASHER, SPRING	1	
26	314-11631-00-96	PISTON STD	1	
	314-11635-00-00	PISTON 1 O/S 0.5	1	
	314-11636-00-00	PISTON 2 O/S 0.0	1	
	316-11631-00-96	PISTON STD	1	
	316-11635-00-00	PISTON 1 O/S 0.5	1	
	316-11636-00-00	PISTON 2 O/S 0.0	1	
	90201-12535-00	WASHER, PLATE	1	
-1	(261-11400-60-00)	CRANKSHAFT ASSEMBLY	1	
-2	(314-11400-02-00)	CRANKSHAFT ASSEMBLY	1	

OIL PUMP

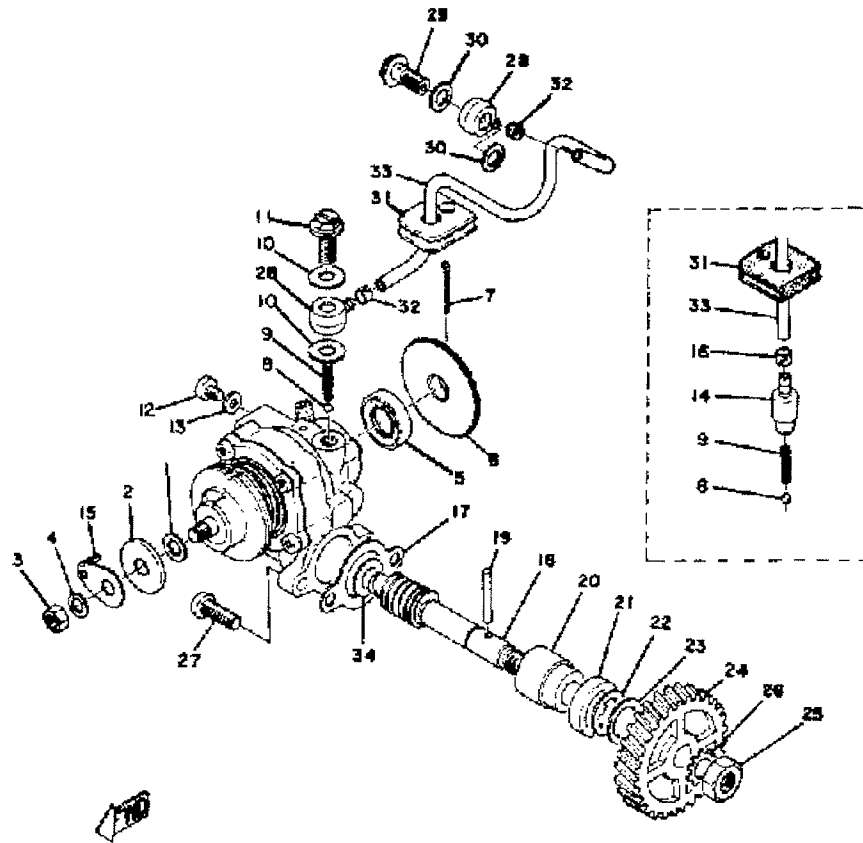

Ref. No.	Part Number	Description	Qty	Remarks
1	137-13137-00-10	SHIM (1.0T)	1	
2	137-13138-01-00	PLATE, ADJUSTING	1	
3	95380-05600-00	NUT	1	
4	92990-05100-00	WASHER, SPRING	1	
5	93101-10090-00	OIL SEAL	1	
6	(137-13128-00-00)	PLATE, STARTER	1	
7	91401-12018-00	PIN, COTTER	1	
8	93505-32002-00	BALL	1	
9	(90501-02017-00)	SPRING, COMPRESSION	1	
10	90430-06011-00	GASKET	2	
11	90401-06011-00	BOLT, UNION	1	
12	98901-04008-00	SCREW, BIND	1	
13	90430-04004-00	GASKET	1	
14	402-13552-00-00	NOZZLE	1	
15	(402-13146-00-00)	COVER, AJST PULLEY	1	
16	90468-02033-00	CLIP	1	
17	3MT-13116-00-00	GASKET, PUMP CASE (8Y0-13116-00)	1	
18	(214-13175-01-00)	SHAFT, WORM	1	
19	93603-22028-00	PIN, DOWEL	1	
20	1E7-13176-00-00	METAL, WRM SHAF OTR	1	
21	93101-10002-00	OIL SEAL	1	
22	93430-08007-00	CIRCLIP	1	AT2/CT2
	99001-08600-00	CIRCLIP	1	
23	90201-105J4-00	WASHER, PLATE (90201-106H1)	1	
24	248-13178-00-00	GEAR, DRIVE (28T)	1	
25	95303-08700-00	NUT	1	
26	92901-08400-00	WASHER, EX.TOOTH	1	

CONTINUED ON NEXT FRAME ►

OIL PUMP

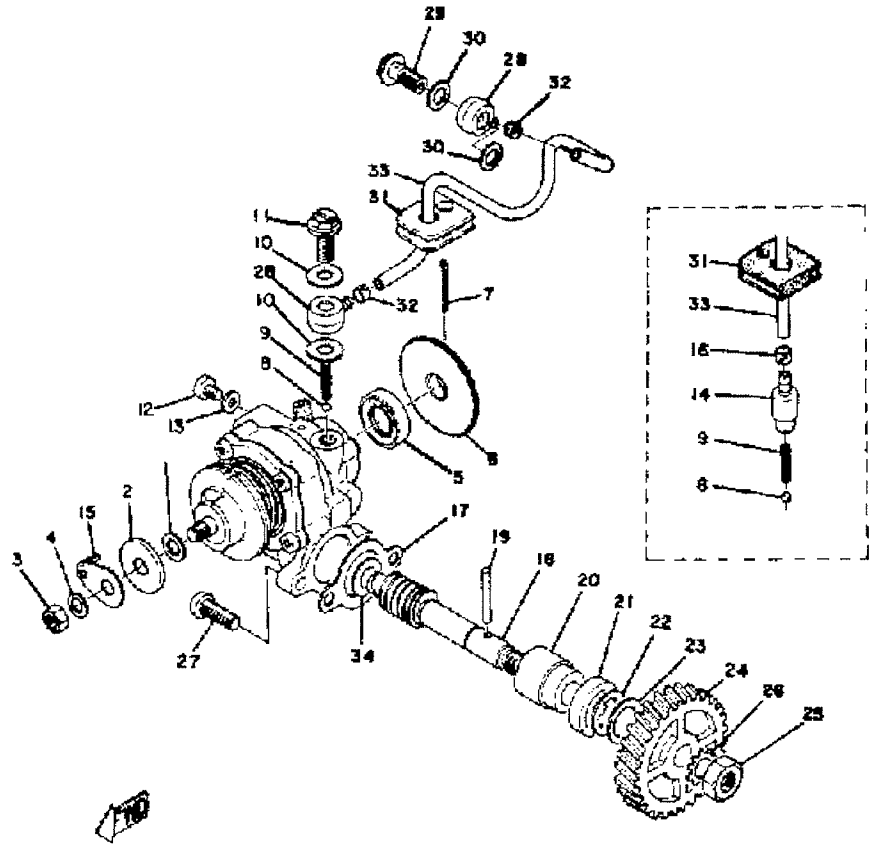

Ref. No.	Part Number	Description	Qty	Remarks
27	98580-05016-00	SCREW, PAN HEAD	2	
28	214-13162-01-00	BANJO, DLVRY PIPE	2	
29	90401-06001-00	BOLT, UNION	1	
30	90430-06011-00	GASKET	2	
31	248-13174-00-00	HOLDER, OIL PIPE	1	
32	90468-02033-00	CLIP	2	
33	90445-05301-00	HOSE (214-13161-01)	1	
34	90201-08624-00	WASHER, PLATE	1	
-1	(214-13101-04-00)	OIL PUMP ASSEMBLY	1	

INTAKE

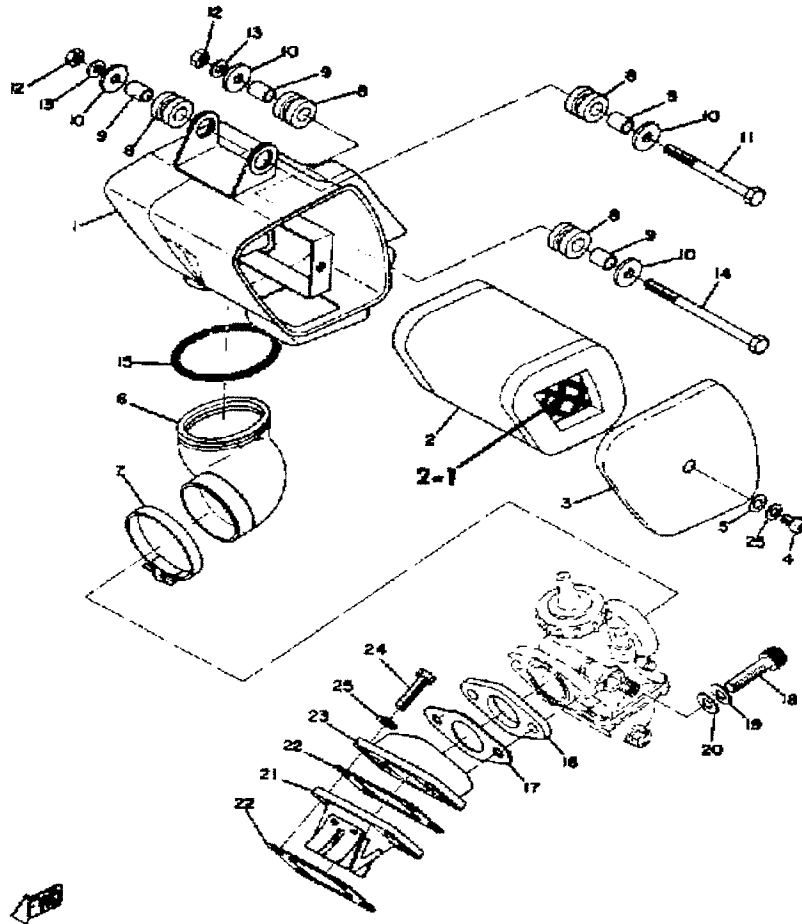

Ref. No.	Part Number	Description	Qty	Remarks
1	(314-14411-00-00)	CASE, AIR CLEANER 1	1	
2	560-14451-09-00	ELEMENT, AIR CLNR	1	
3	392-14412-00-00	CAP, CLEANER CASE 1	1	
4	98580-06010-00	SCREW, PAN HEAD (92503-06010)	1	
5	92990-06200-00	WASHER	1	
6	314-14453-00-00	JOINT, AIR CLNR 1	1	
7	90460-49058-00	CLAMP, HOSE	1	
8	90480-14023-00	GROMMET	4	
9	90387-065L7-00	COLLAR (51L) (214-21633-00)	4	
10	90201-06067-00	WASHER, PLATE	4	
11	97313-06070-00	NUT (97301-06070)	1	
12	95380-06600-00	NUT	2	
13	92995-06100-00	WASHER, SPRING	2	
14	97311-06090-00	BOLT, HEXAGON	1	
15	90506-06106-00	SPRING, TENSION	1	
16	315-13555-00-00	MANIFOLD, INTAKE	1	
17	248-13556-70-00	GASKET, MANIFOLD	1	
18	91316-08030-00	BOLT, SOCKET HEAD	2	
19	92990-08100-00	WASHER	2	
20	92901-08600-00	WASHER	2	
21	314-13610-01-00	REED VALVE ASSEMBLY	1	
22	87A-13621-00-00	GASKET, VALVE SEAT	2	
23	314-13565-00-00	JOINT, CARBURETOR	1	
24	97011-06025-00	BOLT (97001-06025)	4	
25	92995-06100-00	WASHER, SPRING	5	

CARBURETOR

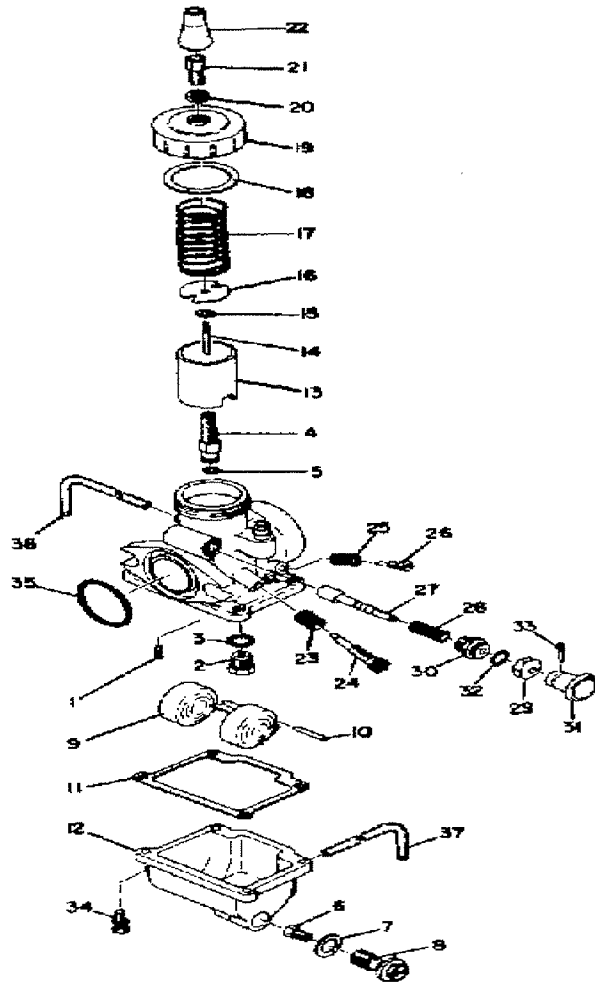

Ref. No.	Part Number	Description	Qty	Remarks
1	260-14142-25-00	. JET, PILOT (# 25)	1	
	260-14142-35-00	. JET, PILOT (# 35)	1	
2	23L-14107-25-00	. NEEDLE VALVE SET	1	
3	214-14195-00-00	. WASHER, NEEDLE VALVE	1	
4	(304-14141-36-00)	. NOZZLE, MAIN	1	
	(314-14141-36-00)	. NOZZLE, MAIN 0 1	213	044~(AT3)
5	214-14147-00-00	. O-RING	1	
6	137-14143-40-A1	. JET, MAIN #2 0	1	
	137-14143-46-A1	. JET, MAIN (#230)	1	044~(AT3)118161~(CT3)
7	304-14198-00-00	. GASKET	1	
8	248-14166-00-00	. BOLT, BANJO	1	
9	314-14185-00-00	. FLOAT	1	
10	371-41860-10-0	. UNAVAILABLE IN PRICE BOOK	1	
11	304-14184-00-00	. GASKET, FLOAT CHAMBER	1	
12	314-14181-08-00	. BODY, FLOAT CHMBR 1	1	
13	314-14112-15-00	. VALVE, THROTTLE 1	1	
	314-14112-20-00	. VALVE, THROTTLE 1	1	
	314-14112-25-00	. VALVE, THROTTLE 1	1	
14	152-14116-10-00	. NEEDLE	1	
	166-14116-13-00	. NEEDLE	1	
	18L-1490J-00-00	. NEEDLE	1	
	316-14116-03-00	. NEEDLE 0 1	213	044~(AT3)
15	164-14137-00-00	. CLIP	1	
16	246-14132-00-00	. STOPPER, CABLE	1	
17	248-14131-00-00	. SPRING, THROTTLE VALVE	1	
18	246-14126-00-00	. GASKET	1	
19	802-14158-00-00	. TOP, MIXING CHAMBER	1	
20	802-14161-00-00	. NUT, CABLE ADJUSTING	1	

CONTINUED ON NEXT FRAME ►

CARBURETOR

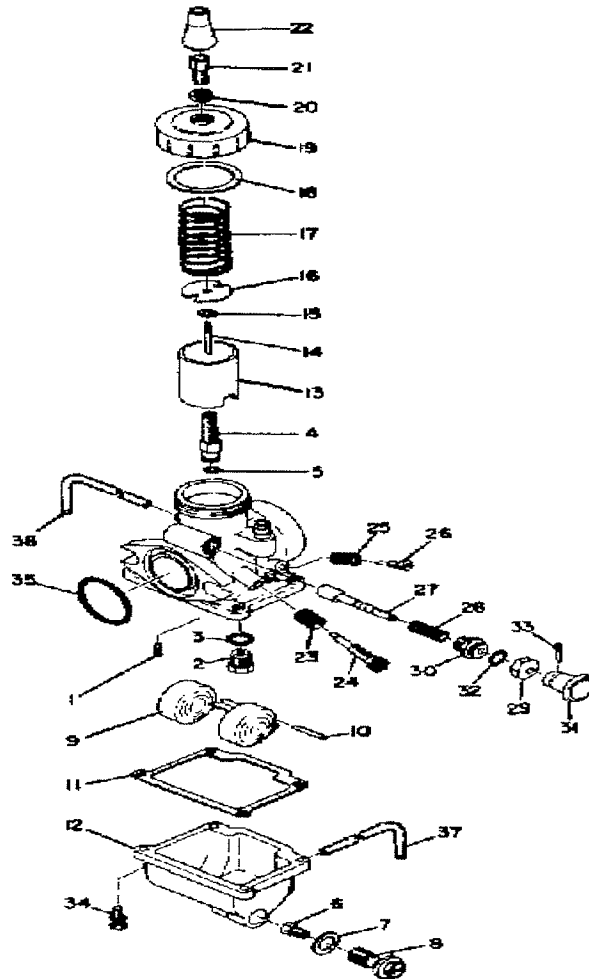

Ref. No.	Part Number	Description	Qty	Remarks
21	12G-14106-00-00	. CABLE ADJUST SCREW SET	1	
22	802-14169-00-00	. CAP	1	
23	137-14133-00-00	. SPRING, THRTL STOP	1	
24	23X-14103-00-00	. THROTTLE SCREW SET	1	
25	174-14134-00-00	. SPRING, AIR ADJUSTING	1	
26	22K-14104-00-00	. AIR SCREW SET	1	
27	304-14171-00-00	. PLUNGER, STARTER	1	
28	156-14135-00-00	. SPRING, PLUNGER	1	
29	132-14173-00-00	. COVER, PLUNGER CAP	1	
30	152-14174-00-00	. CAP, PLUNGER	1	
31	304-14261-00-00	. HOLDER	1	
32	152-14138-00-00	. CLIP, PLUNGER	1	
33	91490-16020-00	. PIN, COTTER	1	
34	98503-04014-00	. SCREW, PAN HEAD	4	
35	248-14147-00-00	. O-RING	1	
36	183-14197-01-00	PIPE, AIRVENT	1	
37	23F-14197-00-00	. PIPE, AIRVENT	1	
-1	(314-14101-00-00)	CARBURETOR ASSEMBLY 1	1	VM 24 SC
	(316-14101-01-00)	CARBURETOR ASSEMBLY 1	1	VM 24 SC

EXHAUST

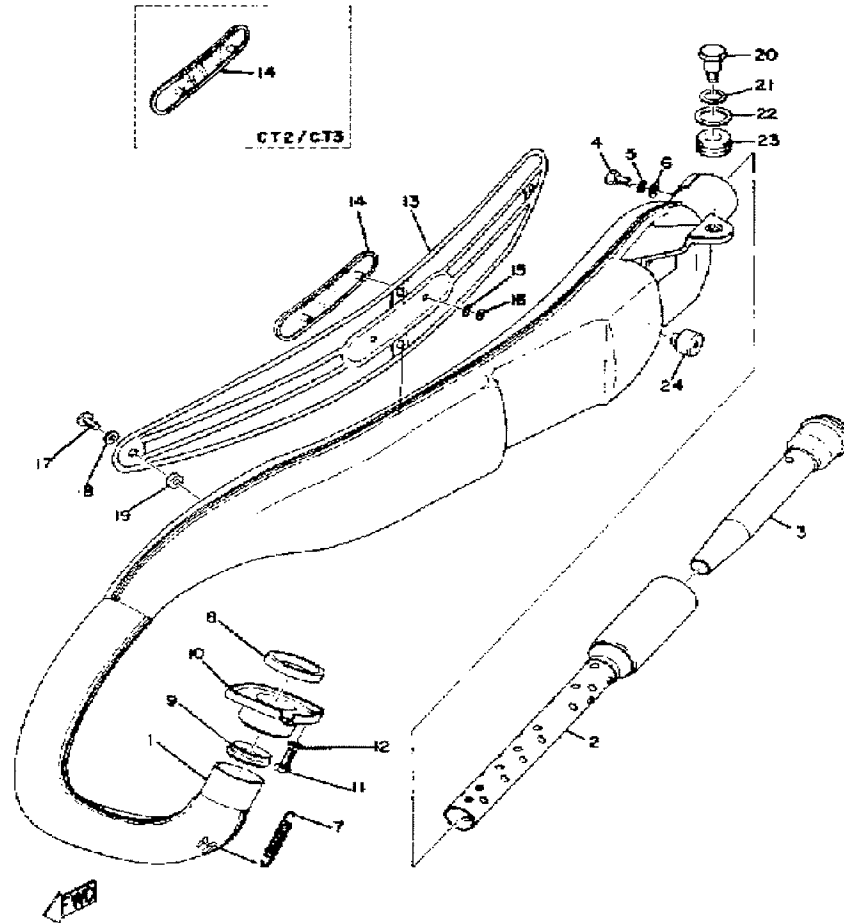

Ref. No.	Part Number	Description	Qty	Remarks
1	(314-14610-30-00)	EXHAUST PIPE ASSEMBLY L	1	
	(316-14610-30-00)	EXHAUST PIPE ASSEMBLY L	1	
2	214-14753-01-00	SILENCER, EXHAUST	1	
3	261-14752-30-00	PIPE, OUTLET	1	
4	97011-06010-00	BOLT	1	
5	92995-06100-00	WASHER, SPRING	1	
6	92990-06200-00	WASHER	1	
7	90506-12029-00	SPRING, TENSION	1	
8	152-14613-00-00	GASKET, EXST PIPE	1	
9	248-14623-00-00	GASKET, EXST PIPE	1	
10	2K5-14612-00-00	NUT, RING	1	
11	97011-06016-00	BOLT	2	
12	92995-06100-00	WASHER, SPRING	2	
13	(314-14718-30-00)	PROTECTOR, MUFF 1	1	
14	(314-14729-30-00)	EMBLEM, PROTECTOR	1	
	(316-14729-30-00)	EMBLEM, PROTECTOR	1	
15	90202-04003-00	WASHER, PLATE	2	
16	90183-04005-00	NUT, SPRING	2	
17	98903-06012-00	SCREW, BIND	4	
18	90202-05187-00	WASHER, PLATE	4	
19	90202-05005-00	WASHER, PLATE (218-14766-10)	4	
20	90109-08391-00	BOLT (276-14719-00)	1	
21	90201-12190-00	WASHER, PLATE	1	
22	90201-18262-00	WASHER, PLATE	1	
23	168-21638-00-00	DAMPER 1	1	
24	116-27114-00-00	STOPPER, MAIN STAND	1	

CRANKCASE COVER

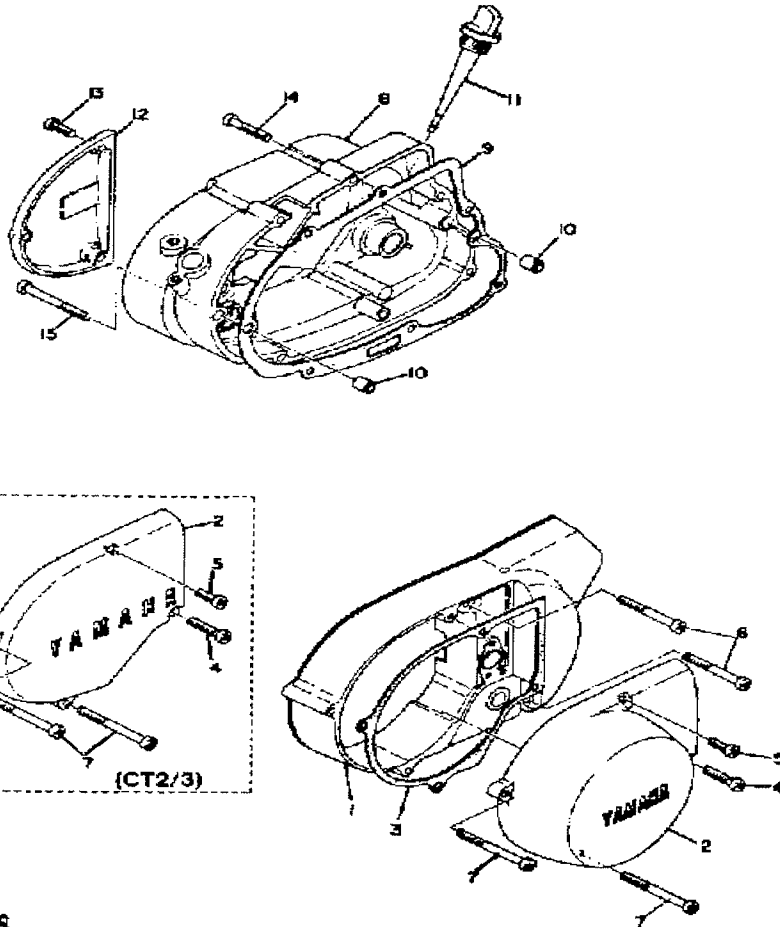

Ref. No.	Part Number	Description	Qty	Remarks
1	482-15411-00-Y4	COVER, CRANKCASE L	1	
2	314-15415-00-Y4	COVER, GENERATOR	1	
	316-15415-00-00	COVER, GENERATOR	1	
3	314-15455-00-00	GASKET 1	1	
4	98580-06030-00	SCREW PAN HEAD	1	
5	98580-06018-00	SCREW, PAN HEAD	1	
	98580-06020-00	SCREW	1	
6	98580-06055-00	SCREW, pan head (92501-06065-00)	2	
7	98580-06565-00	SCREW, PAN HEAD (92501-06065)	2	
8	(314-15421-00-00)	COVER, CRANKCASE R	1	
9	3GY-15451-00-00	GASKET, CRCS COVER 0 1	1	
10	99530-10014-00	PIN, DOWEL	2	
11	315-15362-01-00	PLUG, OIL LEVEL	1	
12	3V6-15416-00-00	COVER, OIL PUMP	1	
13	98580-06018-00	SCREW, PAN HEAD	3	
	98580-06020-00	SCREW	3	
14	98580-06035-00	SCREW, PAN HEAD	6	
15	92580-06560-00	SCREW PAN HEAD	1	

FLYWHEEL MAGNETO

Ref. No.	Part Number	Description	Qty	Remarks
1	(315-81350-10-00)	ROTOR ASSEMBLY	1	
2	277-81312-10-00	. COIL, SOURCE	1	
3	(314-81313-10-00)	COIL, LIGHTING 1	1	
4	97602-04125-00	. SCREW, PN/HD.W/WSHR (4-25)	6	
5	92901-04100-00	. WASHER, SPRING	7	
6	(277-81332-10-00)	PLATE, TIMING	1	
7	207-81321-90-00	. CONTACT BRKR ASSEMBLY	1	
8	110-81346-21-00	. SCREW, PAN HEAD	1	
9	92990-04200-00	. WASHER, PLAIN	1	
10	277-81326-90-00	. CONDENSER 2	1	
11	207-81331-10-00	. LUBRICATOR	1	
12	97601-04106-00	. SCREW, PN/HD.W/WSHR	2	
13	109-81328-11-00	. CLAMP	1	
14	97601-04106-00	. SCREW, PN/HD.W/WSHR	1	
15	98603-06012-00	SCREW, OVAL HEAD (92701-06012)	2	
16	(314-81310-11-00)	BASE ASSEMBLY	1	
-1	(314-81300-10-00)	FLYWHL MAGNETO ASSEMBLY	1	

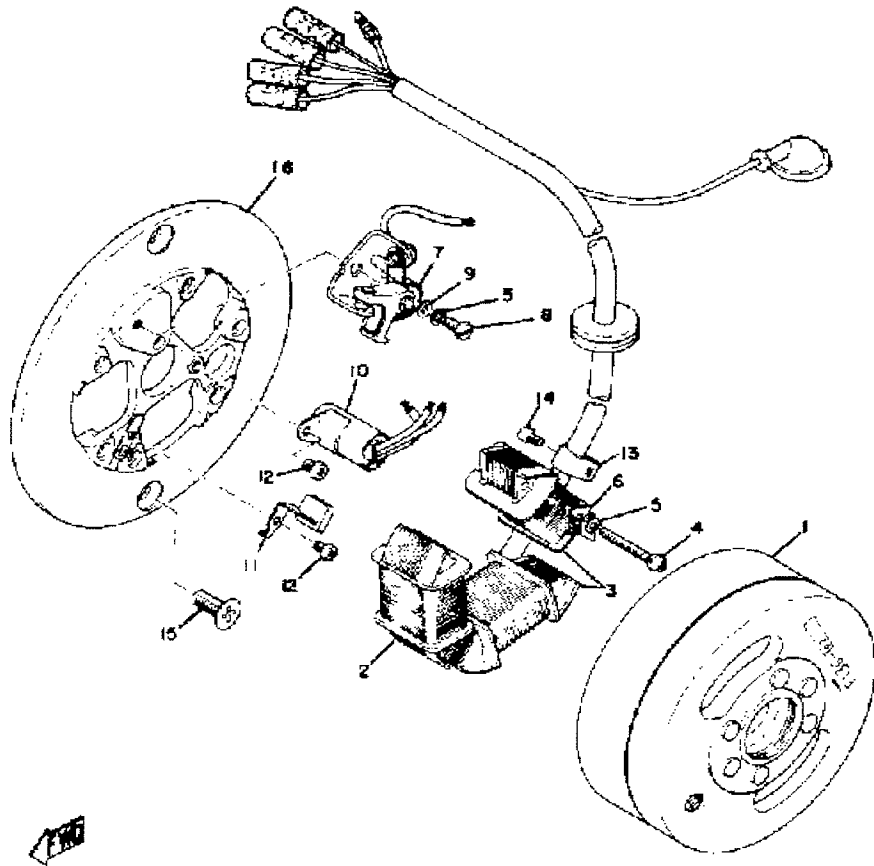

STARTER - GENERATOR (AT2 - 3)

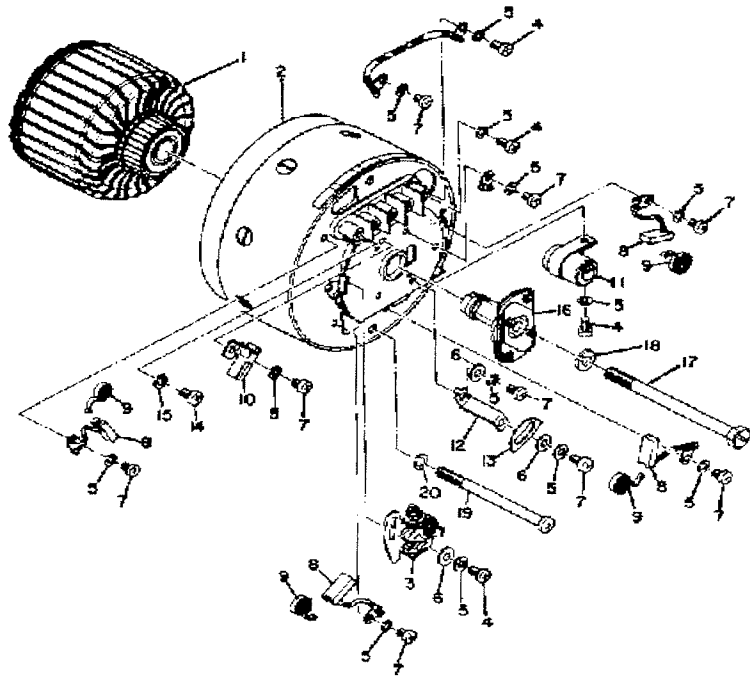

Ref. No.	Part Number	Description	Qty	Remarks
1	(261-81155-10-00)	ARMATURE	1	
	(444-81155-10-00)	ARMATURE	1	
2	(261-81110-10-00)	STATOR ASSEMBLY		
	(444-81110-10-00)	STATOR ASSEMBLY		
3	132-81221-10-00	.. CONTACT BRKR ASSEMBLY	1	
	183-81421-19-00	.. CONTACT BRKR ASSEMBLY	1	
4	98580-04008-00	.. SCREW, PAN HEAD	7	
5	92901-04100-00	.. WASHER, SPRING	15	
6	92990-04200-00	.. WASHER, PLAIN	3	
7	98511-04006-00	.. SCREW, PAN HEAD (98501-04005)	8	
8	101-81111-10-00	.. BRUSH	4	
9	141-81113-10-00	.. SPRING, BRUSH	4	
10	(132-81231-10-00)	LUBRICATOR		
	207-81331-10-00	.. LUBRICATOR	1	
11	148-81126-90-00	.. CONDENSER 2	1	
12	(199-81133-10-00)	FIXTURE, TMNG PLATE	1	
	(299-81133-10-00)	FIXTURE, TMNG PLATE		
13	(133-81132-10-00)	PLATE, TIMING		
14	98580-05010-00	SCREW, PAN HEAD	1	
15	92990-05100-00	WASHER, SPRING	1	
16	(444-81153-10-00)	GOVERNOR ASSEMBLY		
	173-81153-10-00	GOVERNOR ASSEMBLY	1	
17	(148-81152-10-00)	BOLT	1	
18	92990-08100-00	WASHER	1	
19	(261-81135-10-00)	SCREW, STATOR		
20	92990-05100-00	WASHER, SPRING	2	
-1	(444-81100-10-00)	STARTER GEN ASSEMBLY ...		

(AT3)

IGNITION TIMING B.T.D.C. (MM) RETARDED	Govn'r at Full Advance
ADVANCED	1.8 ± .15mm
CONTACT BREAKER POINT GAP SETTING (MM) (INCH)	30-40 .012-.015
SPARK PLUG AND GAP (MM) (INCH)	NGK B-BES .5-.6 .020-.023

KICK - STARTER

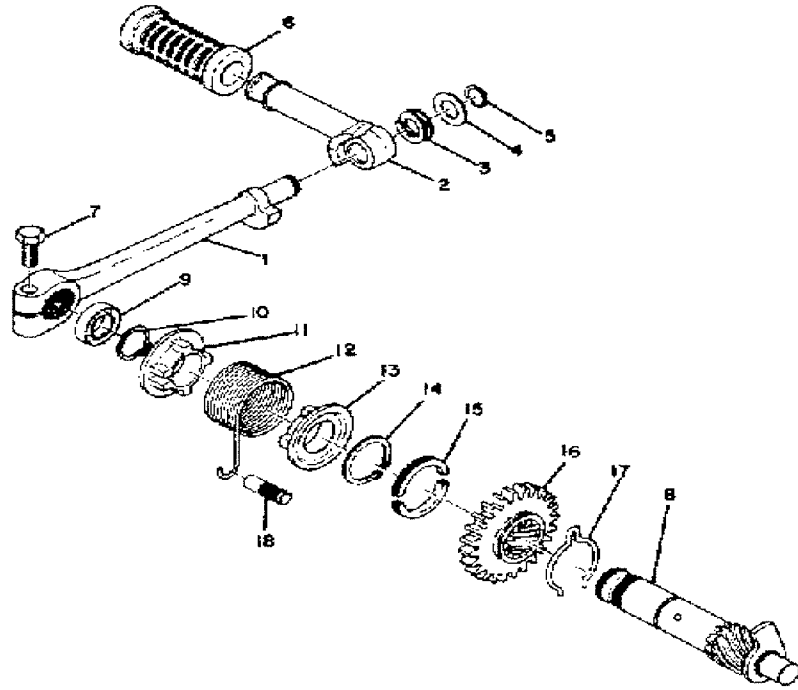

Ref. No.	Part Number	Description	Qty	Remarks
1	---	HOSE, 250 PSI, 3/4X 8		
2	214-15612-01-00	LEVER, KICK	1	
3	90504-18009-00	. SPRING, COMPRESSION (214-15625-01)	1	
4	214-15616-00-00	. WASHER, KICK LEVER	1	
5	93440-11029-00	. CIRCLIP, OUTER	1	
6	214-15618-00-00	COVER, KICK LEVER	1	
7	97313-08030-00	BOLT, HEXAGON		
8	315-15660-01-00	KICK AXLE ASSEMBLY	1	481~(CT2) PN345
	315-15660-01-00	KICK AXLE ASSEMBLY	82	000~(CT2)
9	93104-20007-00	OIL SEAL, SO-TYPE	1	
10	99009-20400-00	CIRCLIP	1	
11	(214-15676-00-00)	COVER, SPRING		
12	90508-26136-00	SPRING, TORSION	1	
13	(214-15664-00-00)	GUIDE, SPRING		
14	99009-30400-00	CIRCLIP	1	
15	248-15654-00-00	HOLDER, KICK GEAR	2	
16	261-15641-00-00	GEAR, KICK	1	
	315-15641-00-00	GEAR, KICK (27T)	1	481~(CT2) PN345
17	90468-26048-00	CLIP	1	481~(CT2) PN345
18	248-15668-00-00	STOPPER	1	
-1	3V6-15620-00-00	KICK CRANK ASSEMBLY	1	



CLUTCH

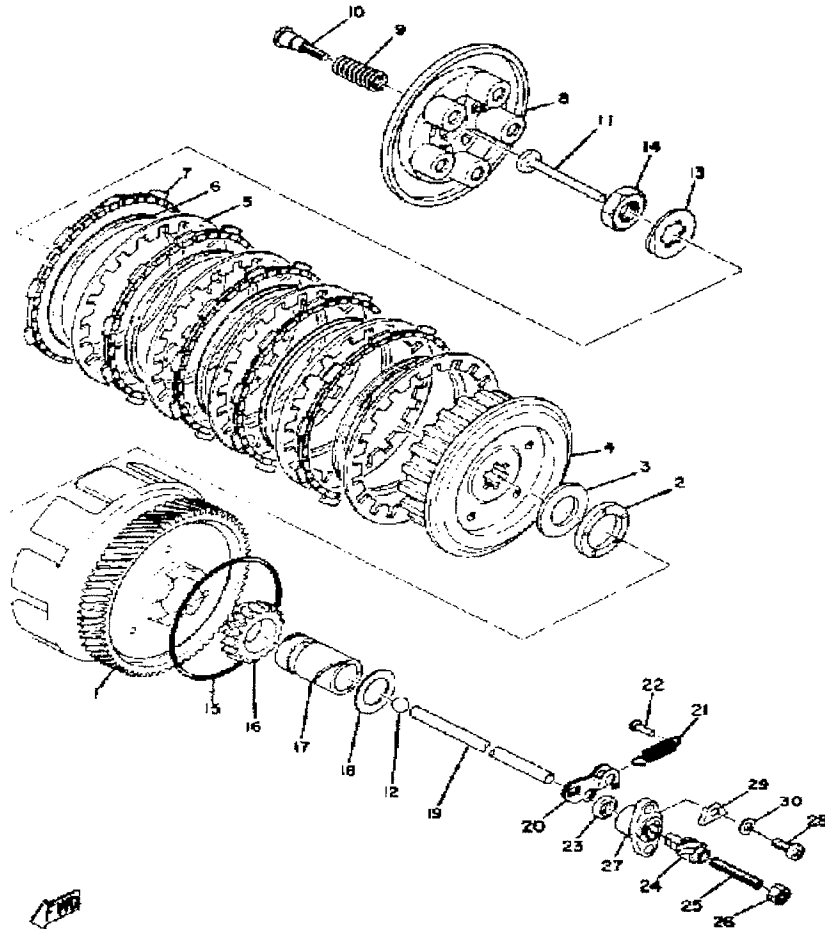

Ref. No.	Part Number	Description	Qty	Remarks
1	(248-16150-02-00)	PRI DRVN GEAR	1	
2	93341-22603-00	. BEARING, FLAT # 1	1	
3	174-16154-00-00	. PLATE, THRUST 1	1	
4	174-16371-01-00	. BOSS, CLUTCH	1	
5	137-16324-00-00	. PLATE, CLUTCH 1	5	
6	137-16367-00-00	. RING, CUSHION	5	
7	132-16321-01-00	. PLATE, FRICTION	5	
8	132-16351-00-00	. PLATE, PRESSURE 1	1	
9	90501-20125-00	. SPRING, COMPRESSION	5	
10	(90149-05147-00)	SCREW, SPECL SHAPE	5	
11	137-16356-00-00	ROD, PUSH 1	1	
12	93501-04011-00	BALL	1	
13	90215-16020-00	WASHER, LOCK	1	
14	90179-16018-00	NUT	1	
15	93210-85075-00	O-RING	1	
16	261-15631-01-00	GEAR, KICK PINION	1	
17	90387-20439-00	COLLAR (174-16181-00)	1	
18	248-16164-01-00	PLATE, THRUST 2	1	
19	248-16357-00-00	ROD, PUSH 2	1	
20	241-16342-00-00	LEVER, PUSH	1	
21	90506-10019-00	SPRING, TENSION	1	
22	132-16346-00-00	HOOK, SPRING	1	
23	93104-10085-00	OIL SEAL, SO-TYPE	1	
24	241-16341-01-00	SCREW, PUSH	1	
25	90113-06013-00	BOLT, SET	1	
26	95380-06700-00	NUT	1	
27	314-16396-01-00	HOUSING, PUSH SCREW	1	
28	98503-06014-00	SCREW, PAN HEAD (92502-06016)	2	

CONTINUED ON NEXT FRAME ►

CLUTCH

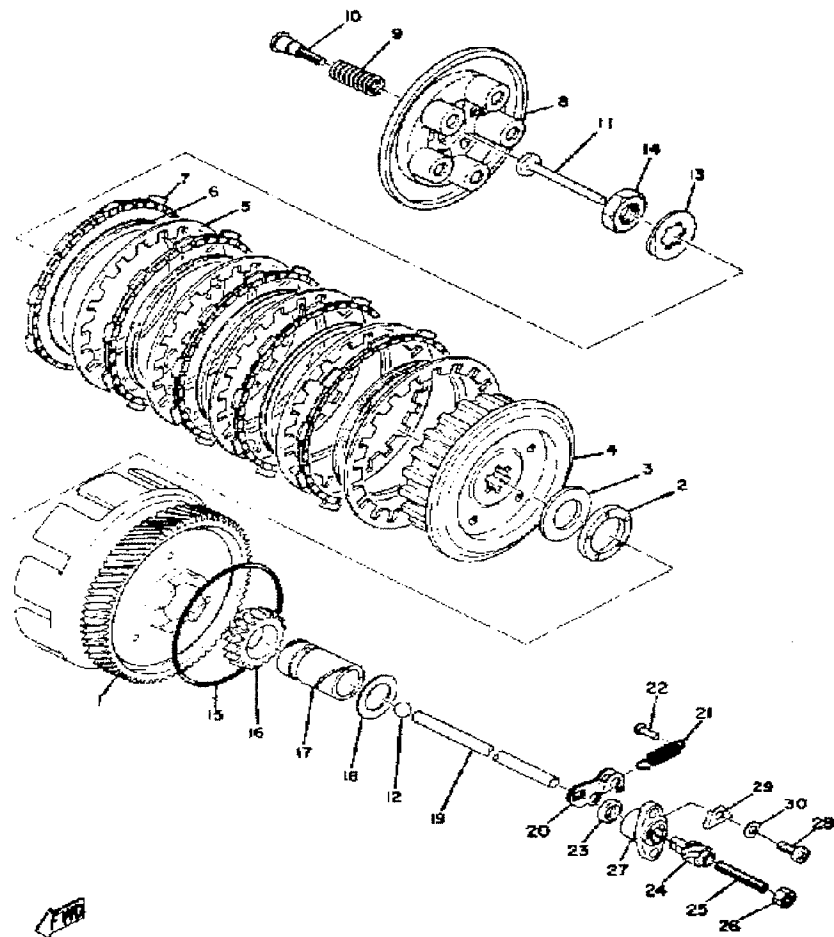

Ref. No.	Part Number	Description	Qty	Remarks
29	92901-06600-00	WASHER	2	
30	92995-06100-00	WASHER, SPRING	2	
-1	(248-16301-02-00)	CLUTCH ASSEMBLY	1	

TRANSMISSION

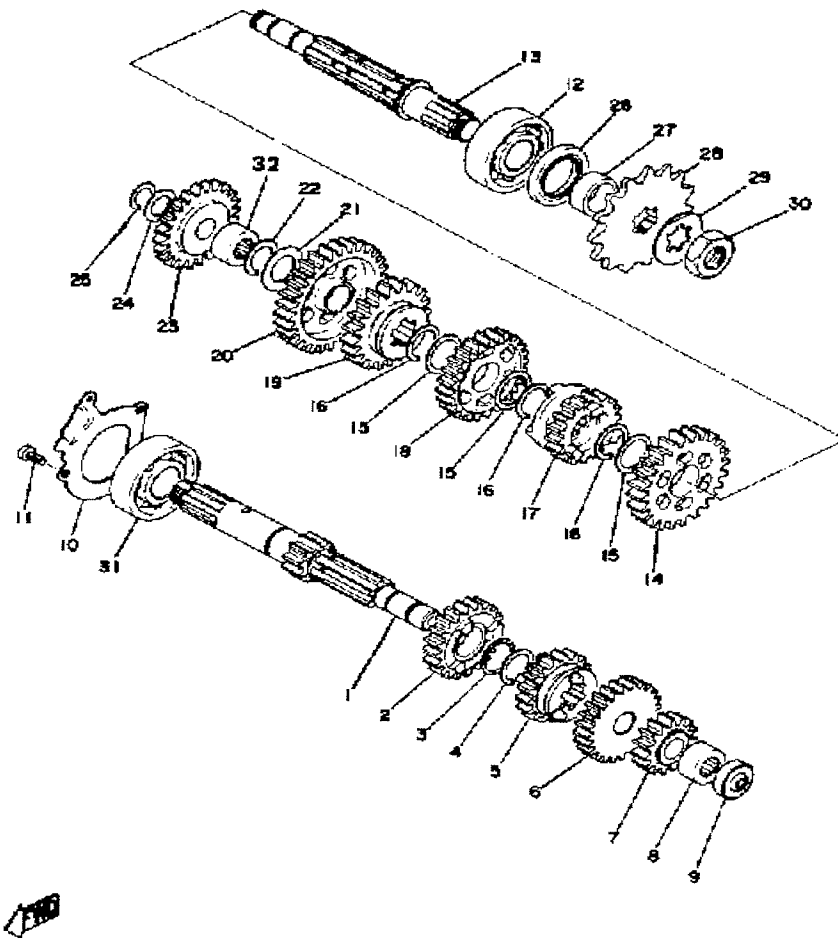

Ref. No.	Part Number	Description	Qty	Remarks
1	(248-17411-01-00)	AXLE, MAIN	1	
2	(248-17141-00-00)	GEAR, 4TH PINION	1	
3	90201-20266-00	. WASHER, PLATE (1.0T)	1	
4	93410-20038-00	. CIRCLIP	1	
5	248-17131-00-00	. GEAR, 3RD PINION (19T)	1	
6	(248-17151-00-00)	GEAR, 5TH PINION	1	
7	(248-17121-01-00)	GEAR, 2ND PINION	1	
8	93315-31502-00	BEARING	1	
9	93109-06060-00	SEAL, PUSH ROD	1	
10	(248-17471-01-00)	PLATE, COVER	1	
	401-17471-00-00	PLATE, COVER	1	
11	98580-05012-00	SCREW, PAN HEAD	3	
12	93306-30421-00	BEARING (B6304C3)	1	
13	315-17421-01-00	AXLE, DRIVE	1	
14	(315-17221-00-00)	GEAR, 2ND WHEEL	1	PN317
15	90201-20266-00	WASHER, PLATE (1.0T)	3	
16	93410-20038-00	CIRCLIP	3	
17	(314-17251-00-00)	GEAR, 5TH WHEEL	1	PN317
18	427-17231-00-00	GEAR, 3RD WHEEL (26T)	1	PN317
19	248-17241-00-00	GEAR, 4TH WHEEL (23T)	1	
20	248-17211-00-00	GEAR, 1ST WHEEL (35T)	1	
21	164-17427-00-06	SHIM 1 (0.6T)	1	
22	93440-15012-00	CIRCLIP	1	
23	261-15651-00-00	GEAR, KICK IDLE	1	
	401-15651-00-00	GEAR, KICK IDLE	1	
24	(132-15653-00-14)	WASHER	1	U.R.
	132-15653-00-12	WASHER (13.3-22-1.2)	1	U.R.
25	99009-13400-00	CIRCLIP (55X)	1	
26	93102-26042-00	OIL SEAL	1	

CONTINUED ON NEXT FRAME ►

TRANSMISSION

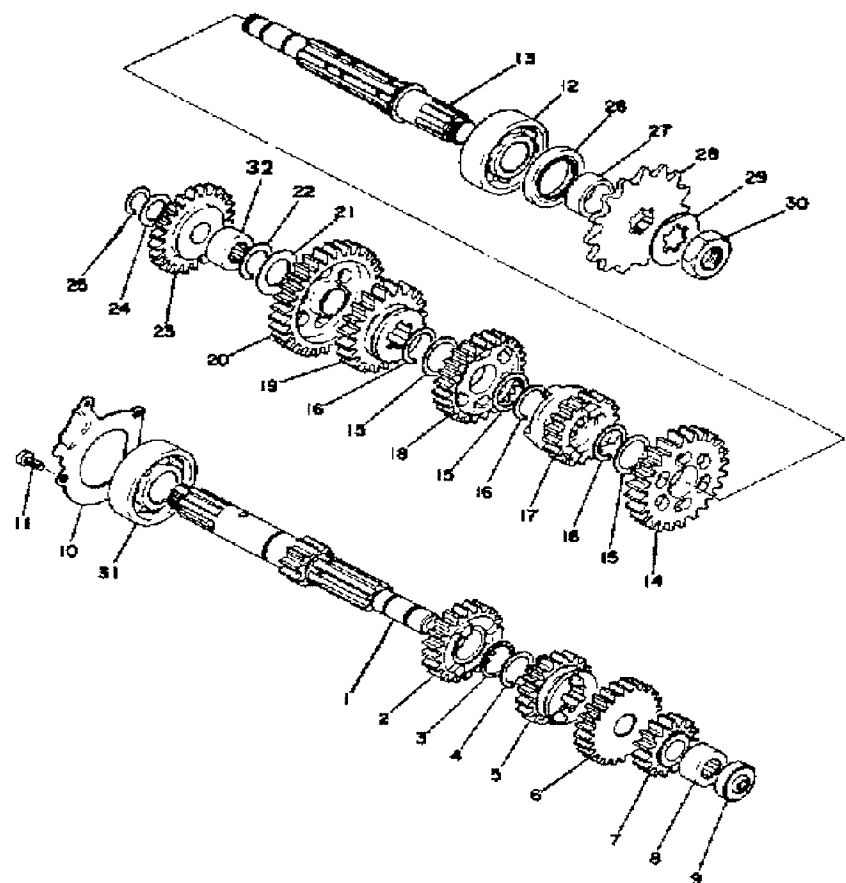

Ref. No.	Part Number	Description	Qty	Remarks
27	90387-20491-00	COLLAR	1	
28	93822-13024-00	SPROCKET, DRIVE 13T (1741746130)	1	
	93822-14037-00	SPROCKET, DRIVE 14T (1741746140)	1	U.R. STD (AT)
	93822-15065-00	SPROCKET, DRIVE 15T (1741746150)	1	U.R. STD (CT)
	93822-16093-00	SPROCKET, DRIVE	1	U.R.
29	90215-16020-00	WASHER, LOCK	1	
30	90179-16018-00	NUT	1	
31	93306-30408-00	BEARING	1	
32	93315-31502-00	BEARING	1	
-1	(248-17401-00-00)	MAIN AXLE ASSEMBLY	1	
32-1	93311-31507-00	BEARING, CYLINDER.#11 (DIA. 23MM)	1	
32-2	93311-31567-00	BEARING, CYLINDRICAL	1	

TACHOMETER

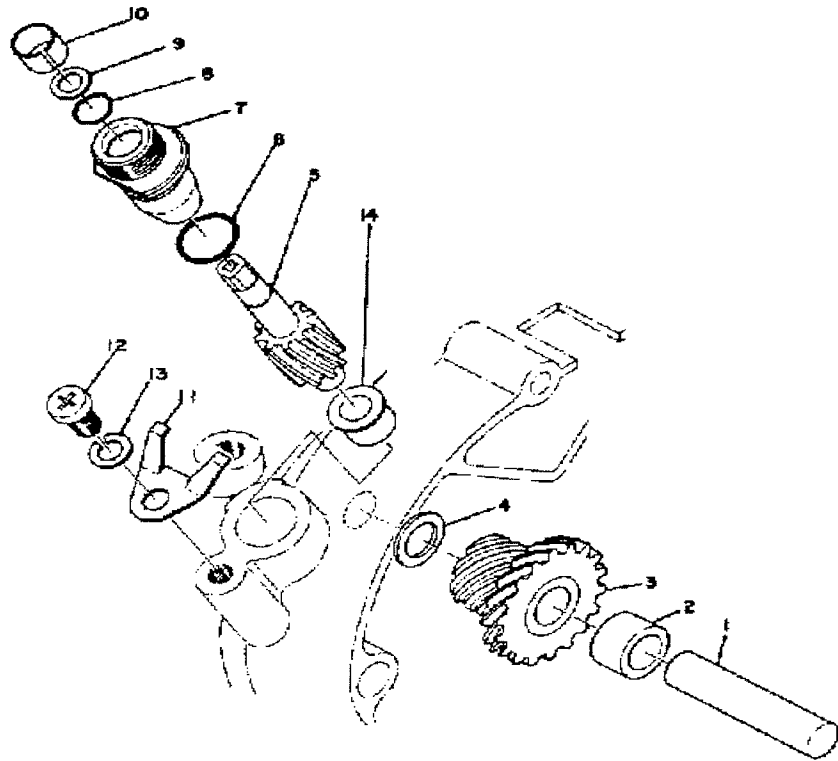

Ref. No.	Part Number	Description	Qty	Remarks
1	(248-17861-00-00)	AXLE, DRIVE GEAR	1	
2	90387-10087-00	COLLAR	1	
3	248-17831-02-00	GEAR, DRIVE	1	
4	248-17837-00-00	SHIM	1	
5	(248-17841-00-00)	GEAR, DRIVEN	1	
6	93210-13016-00	O-RING	1	
7	353-17810-00-00	HOUSING ASSEMBLY, TACH (214-17811-01)	1	
8	93210-07100-00	O-RING	1	
9	214-17847-00-00	SHIM (7.5-10.8-0.4)	1	
10	90383-10005-00	BUSH, FORMED (214-17815-00) 0 1	1	
11	5U7-17812-00-00	STOPPER	1	
12	98580-06010-00	SCREW, PAN HEAD (92503-06010)	1	
13	92995-06100-00	WASHER, SPRING	1	
14	90381-08002-00	BUSHING (214-17843-00)	1	



SHIFT CAM - FORK

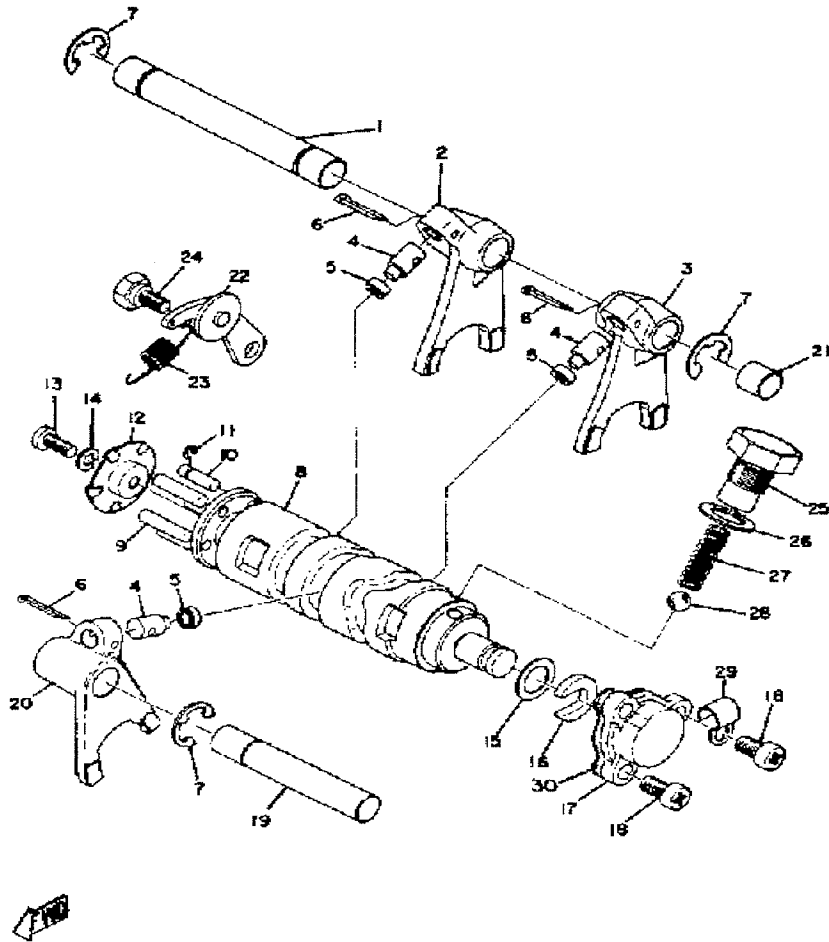

Ref. No.	Part Number	Description	Qty	Remarks
1	214-18531-00-00	BAR, SHIFT FORK GUIDE 1	1	
2	463-18513-00-00	FORK, SHIFT 3	1	
3	463-18511-00-00	FORK, SHIFT 1	1	
4	(90249-05035-00)	PIN, SPEC'L SHAPE	3	PN402
	90250-08017-00	PIN, STRAIGHT	3	
5	136-18551-00-00	ROLLER, CAM FOLWR	3	DISCONTINUED
6	91401-25020-00	PIN, COTTER	3	DISCONTINUED
7	93430-10017-00	CIRCLIP	3	
8	315-18540-00-00	SHIFT CAM ASSEMBLY	1	
9	93604-22050-00	PIN, DOWEL	4	
10	90249-04039-00	PIN, SPEC'L SHAPE (174-18544-00)	1	
11	93430-03014-00	CIRCLIP, E-TYPE	1	
12	164-18561-00-00	PLATE, SIDE 1	1	
13	98580-05012-00	SCREW, PAN HEAD	1	
14	92990-05100-00	WASHER, SPRING	1	
15	90201-12166-00	WASHER, PLATE	1	
16	164-18571-01-00	HOLDER, SHIFT CAM	1	
17	164-18589-00-00	PLUG, BLIND	1	
18	98580-06010-00	SCREW, PAN HEAD (92503-06010)	3	
	98580-06012-00	SCREW, PAN HEAD	3	
19	(248-18531-00-00)	BAR, SHIF FRK GDE 1	1	
20	463-18512-00-00	FORK, SHIFT 2	1	
21	214-15385-00-00	PLUG, BLIND	1	
22	132-18140-01-00	STOPPER LEVER ASSEMBLY	1	
23	90506-09112-00	SPRING, TENSION	1	
24	90109-06001-00	BOLT	1	
25	90109-14385-00	BOLT	1	

CONTINUED ON NEXT FRAME ►

SHIFT CAM - FORK

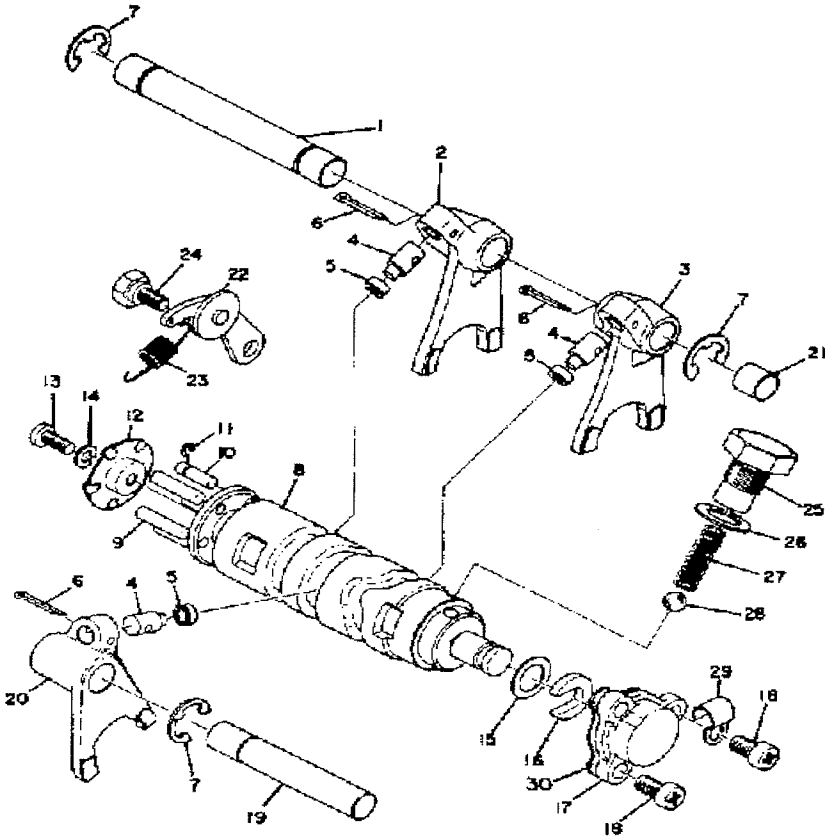

Ref. No.	Part Number	Description	Qty	Remarks
26	137-15353-00-00	GASKET, DRAIN	1	
27	90501-12083-00	SPRING, COMPRESSION (174-18558-00)	1	
28	93505-16006-00	BALL	1	
29	(90462-05012-00)	CLAMP	1	
30	4Y2-18579-00-00	GASKET, PLUG BLIND	1	

SHIFT SHAFT

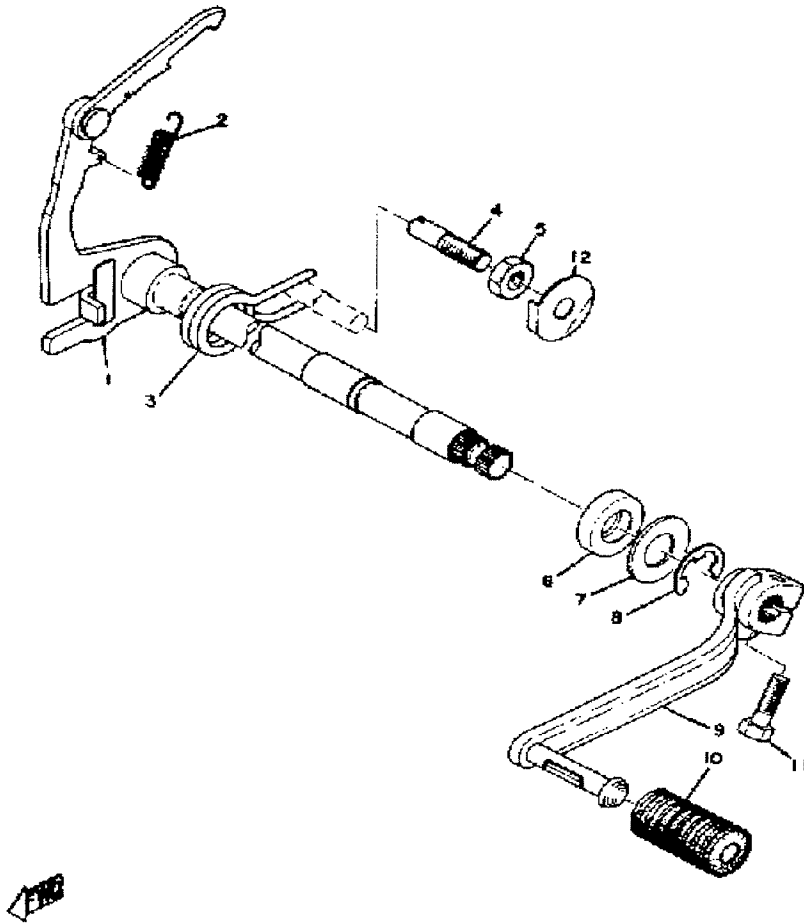

Ref. No.	Part Number	Description	Qty	Remarks
1	248-18101-02-00	SHIFT SHAFT ASSEMBLY. 1	1	
2	90506-09009-00	. SPRING, TENSION	1	
3	90508-32207-00	SPRING, TORSION (132-18124-00)	1	
4	90149-08094-00	SCREW	1	
5	90170-08029-00	NUT	1	
6	93109-14010-00	OIL SEAL, SDO-TYPE	1	
7	90201-14220-00	WASHER, PLATE	1	
8	99001-12600-00	CIRCLIP	1	
9	173-18111-01-93 367-18111-00-00	PEDAL, SHIFT PEDAL SHIFT	1	
10	132-18113-01-00	COVER, SHIFT PEDAL	1	
11	97011-06020-00	BOLT	1	
12	90215-08014-00	WASHER, LOCK	1	

FRAME

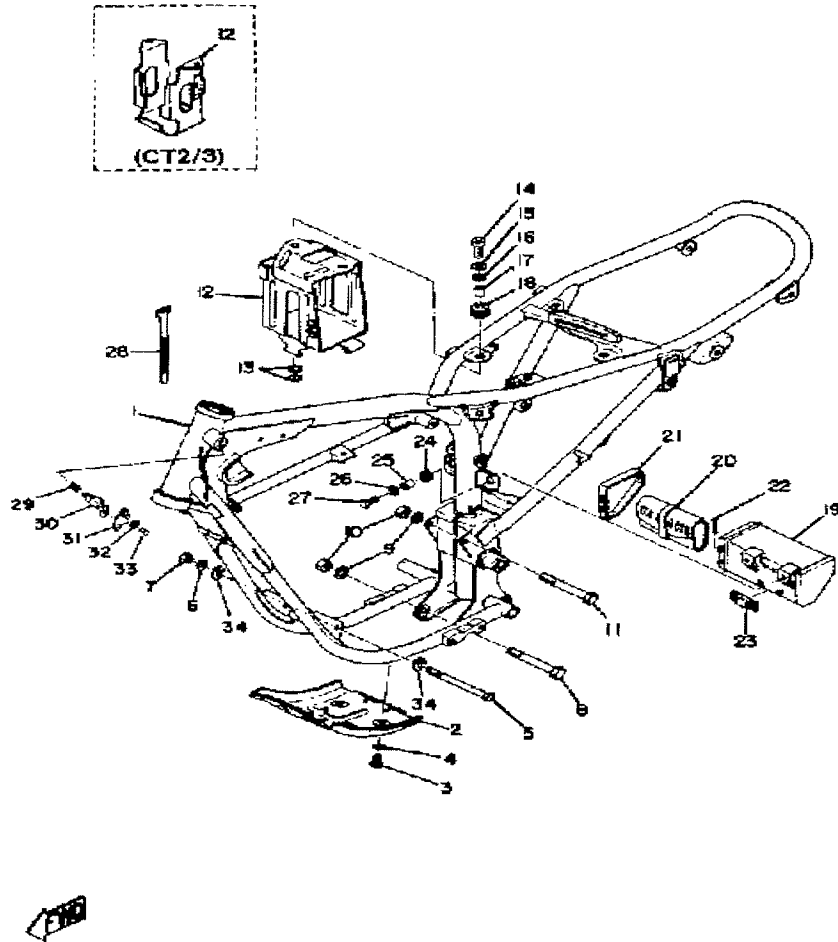

Ref. No.	Part Number	Description	Qty	Remarks
1	(314-21110-00-33)	FRAME	1	
	(315-21110-00-33)	FRAME	1	
2	(248-21471-00-33)	PROTECTOR, ENGINE	1	
3	97013-06012-00	BOLT	4	
4	92990-06200-00	WASHER	4	
5	90105-08024-00	BOLT, WASHER BASED		
	95811-08110-00	BOLT, FLANGE	1	
6	92990-08100-00	WASHER	1	
7	95333-08600-00	NUT	1	
	95611-08100-00	NUT, U	1	
8	97021-10095-00	BOLT, HEXAGON	1	
	97321-10090-00	BOLT, HEXAGON (91101-10090)	1	
9	92990-10100-00	WASHER, SPRING	2	
10	95303-10600-00	NUT (95301-10600)	2	
11	95821-10200-00	BOLT, FLANGE	1	
12	(261-21240-00-33)	BOX, BATT.	1	
	(315-21240-00-33)	BOX, BATT.	1	
13	93210-12014-00	O-RING	2	
14	98511-06025-00	SCREW PAN HEAD (92501-06025)	2	
15	92995-06100-00	WASHER, SPRING	2	
16	90201-06074-00	WASHER, PLATE	2	
	92990-06200-00	WASHER	2	
17	90387-065L7-00	COLLAR (51L) (214-21633-00) ..	2	
18	248-21717-00-00	DAMPER	2	
19	(248-21170-00-33)	BOX, TOOL	1	
20	(315-W2810-10-00)	TOOL KIT	1	
21	(248-21399-00-00)	CAP, TOOL BOX	1	
22	91401-25030-00	PIN, COTTER	1	

CONTINUED ON NEXT FRAME ►

FRAME

Ref. No.	Part Number	Description	Qty	Remarks
23	(248-21746-00-00)	DAMPER	1	
24	90480-14023-00	GROMMET	2	
25	90387-065L7-00	COLLAR (51L) (214-21633-00) .	2	
26	90201-06067-00	WASHER, PLATE	2	
27	97011-06020-00	BOLT	2	
28	437-83936-11-00	BAND, SWITCH CORD	1	
29	90502-08005-00	SPRING, CONICAL (214-23485-00)	1	
30	341-23408-01-00	STEERING LOCK ASSEMBLY (214-23480-00)	1	
31	(134-23484-10-00)	CAP, HANDLE LOCK	1	
32	90206-04003-00	WASHER, WAVE (214-23488-00)	1	
33	90269-04003-00	RIVET	1	
34	90209-08050-00	WASHER, SPEC'L SHAP	2	

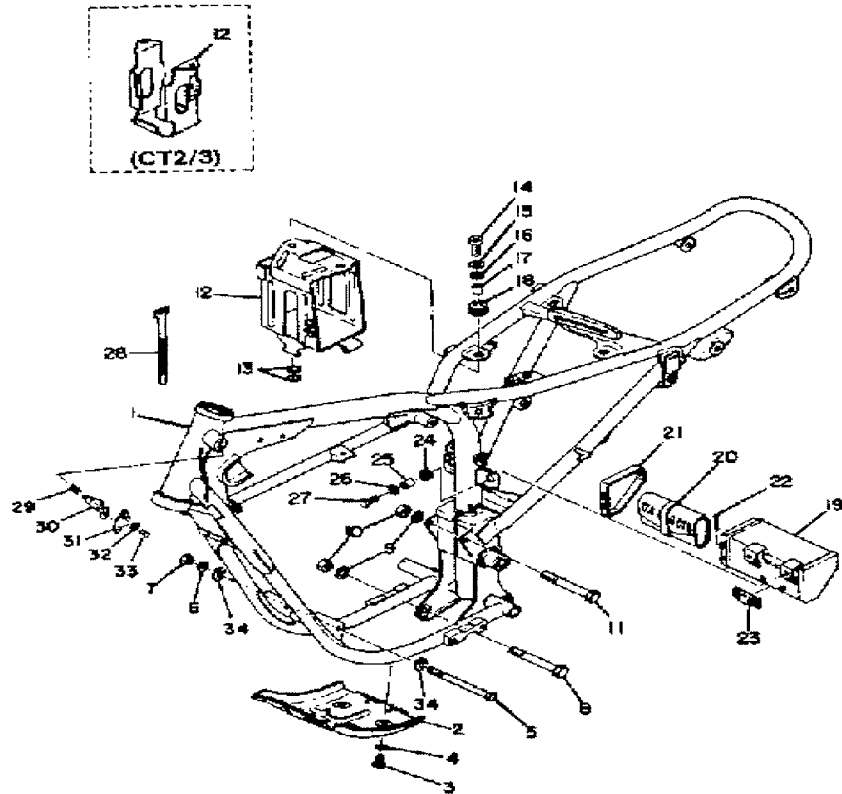

FRONT FENDER - REAR FENDER

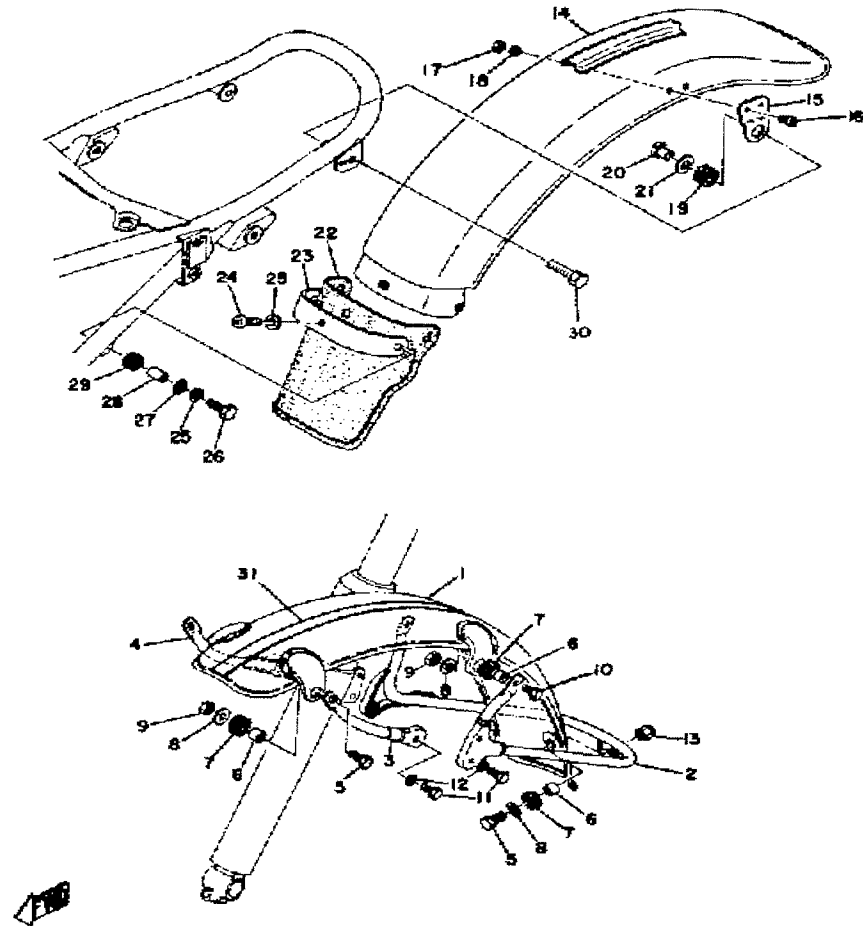

Ref. No.	Part Number	Description	Qty	Remarks
1	(214-21510-00-35)	FENDER, FRONT	1	
	(248-21510-00-35)	FENDER, FRONT	1	
2	(214-21512-00-93)	BRACKET, FENDER	1	
	(248-21512-00-93)	BRACKET, FENDER	1	
3	(214-21513-00-00)	STAY, FENDER 1	1	
	(248-21513-00-00)	STAY, FENDER 1	1	
4	(214-21514-00-00)	STAY, FENDER 2	1	
	248-21514-00-00	STAY, FENDER 2	1	
5	97011-06020-00	BOLT	3	
6	90387-065L7-00	COLLAR (51L) (214-21633-00)	5	
7	90480-14023-00	GROMMET	5	
8	90201-06067-00	WASHER, PLATE	5	
9	95380-06600-00	NUT	4	
10	97011-06025-00	BOLT (97001-06025)	2	
11	97011-06020-00	BOLT	4	
12	92995-06100-00	WASHER, SPRING	4	
13	95303-06800-00	NUT (CROWN)	1	
14	(316-21610-00-35)	FENDER, REAR	1	
	(444-21610-00-35)	FENDER, REAR	1	
15	(248-21613-00-91)	STAY, FENDER 1	2	
16	98580-06012-00	SCREW, PAN HEAD	4	
17	95380-06600-00	NUT	4	
18	92995-06100-00	WASHER, SPRING	4	
19	168-21638-00-00	DAMPER 1	2	
20	248-21635-00-00	NUT, REAR FENDER	2	
21	90201-12472-00	WASHER, PLATE	2	
22	(248-21629-00-00)	GUARD, MUD	1	
23	(248-21622-00-33)	BAND, FLAP	1	
24	98580-06012-00	SCREW, PAN HEAD	1	

CONTINUED ON NEXT FRAME ►

REAR ARM - REAR CUSHION - CHAIN C4

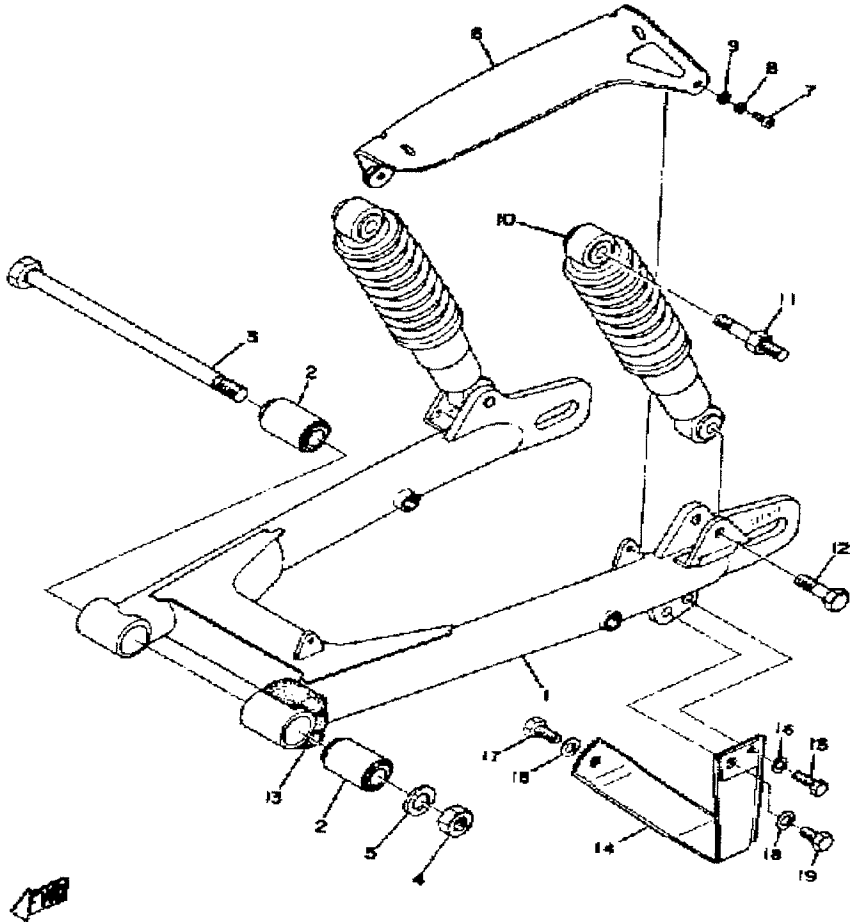

Ref. No.	Part Number	Description	Qty	Remarks
1	(315-22110-01-33)	REAR ARM	1	
2	174-22123-00-00	BUSH 1	2	
3	(248-22141-00-00)	SHAFT, PIVOT	1	
4	95312-14600-00	NUT	1	
5	92901-14100-00	WASHER, SPRING	1	
6	(315-22311-00-35)	CASE, CHAIN	1	
7	98580-05010-00	SCREW, PAN HEAD	2	
8	92990-05100-00	WASHER, SPRING	2	
9	92990-05200-00	WASHER, PLAIN	2	
10	291-22210-71-00	SHK/ABS. ASSEMBLY, REAR	2	
11	(90116-10115-00)	BOLT, STUD	2	
12	(90106-10026-00)	BOLT, DOME HEAD	2	
13	(248-22151-00-00)	SEAL, GUARD	1	
14	(248-22318-00-33)	GUARD, CHAIN	1	
15	97011-06020-00	BOLT	1	
16	92995-06100-00	WASHER, SPRING	1	
17	97313-08018-00	BOLT, HEXAGON (97301-08016)	1	
18	92990-08100-00	WASHER	2	
19	97313-08020-00	BOLT, HEXAGON	1	
10-1	(291-22213-71-00)	SEAT, SPRING UPPER	4	

FRONT FORK

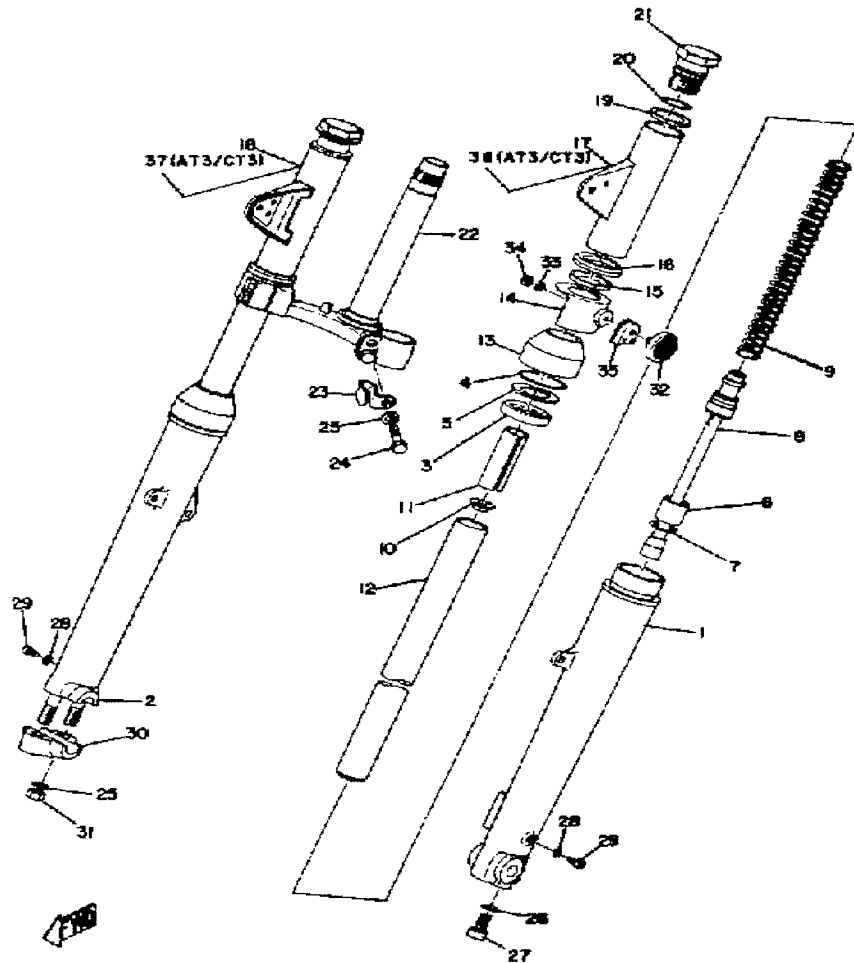

Ref. No.	Part Number	Description	Qty	Remarks
1	(315-23126-50-00)	TUBE, OUTER 1	1	
2	(315-23136-50-00)	TUBE, OUTER 2	1	
3	137-23145-01-00	. . OIL SEAL	2	
4	(315-23156-50-00)	CLIP, OIL SEAL	2	
5	(315-23146-50-00)	WASHER, OIL SEAL	2	
6	(315-23171-50-00)	PISTON, FRONT FORK	2	
7	(535-23183-01-00)	CIRCLIP	2	
8	(315-23170-50-00)	CYLINDER, FRTRFK	2	
9	318-23141-00-00	. SPRING, FRONT FORK	2	
10	(248-23142-00-00)	SEAT, SPRING UPPER	2	
11	(315-23118-50-00)	SPACER	2	
12	(315-23124-50-00)	TUBE, INNER 1	2	
13	248-23144-00-00	. SEAL, DUST	2	
14	(261-23122-61-00)	COVER, OUTER 1	2	
15	291-23163-61-00	. GASKET (LAMP STAY)	2	
16	(248-23116-01-00)	GUIDE, COVER LOWER	2	
17	(248-23121-01-71)	COVER, UPPER 1	1	
	(92123-11606-3)	. UNAVAILABLE IN PRICE BOOK	1	
18	(248-23131-01-71)	COVER, UPPER 2	1	
	(291-23131-60-63)	COVER, UPPER 2	1	
19	(248-23115-01-00)	GUIDE, COVER UPPER	2	
20	146-23114-00-00	. GASKET	2	
21	(2K5-23111-00-00)	BOLT, CAP	2	
22	(248-23340-51-33)	UNDER BRACKET	1	
23	(256-23318-60-00)	HOLDER, CABLE 1	1	
24	18G-23128-00-00	. BOLT, W/WASHER	4	
25	92990-08100-00	. WASHER	2	
26	(214-23158-00-00)	GASKET	2	

CONTINUED ON NEXT FRAME ►

FRONT FORK

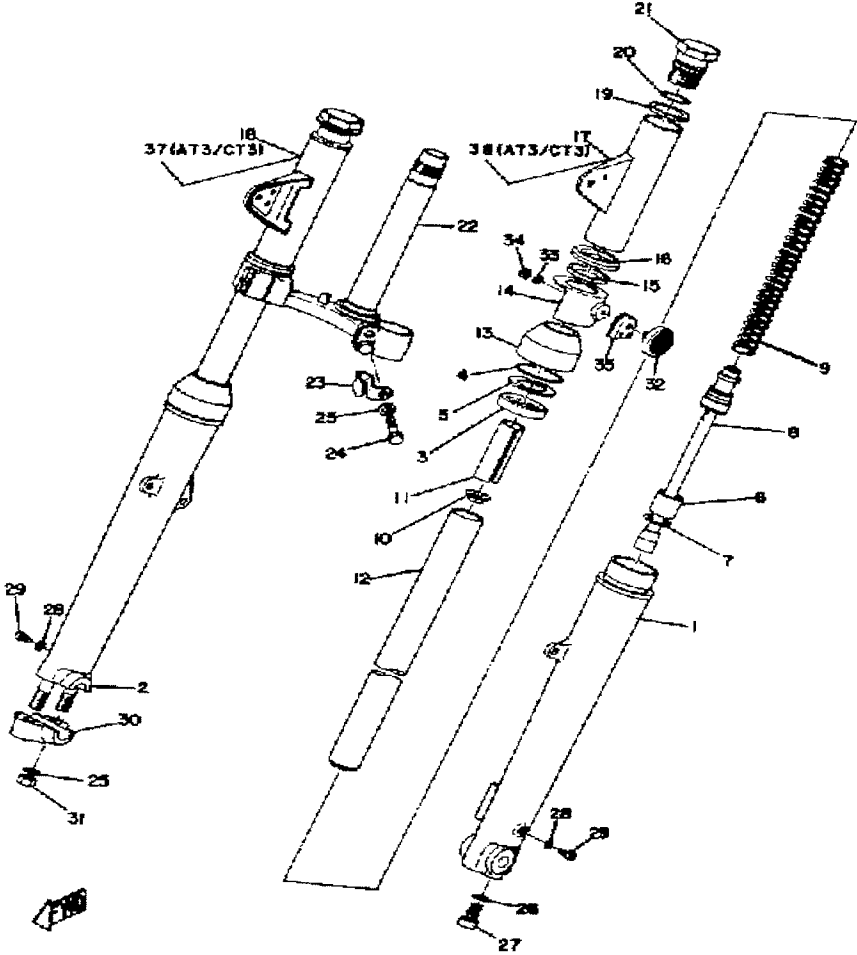

Ref. No.	Part Number	Description	Qty	Remarks
27	91311-08020-00	. BOLT, SOCKET HEAD	2	
28	122-23129-00-00	. GASKET, DRAIN PLUG	2	
29	98580-04008-00	. SCREW, PAN HEAD	2	
30	315-23167-51-00	. HOLDER, AXLE	1	
31	95333-08600-00	. NUT	2	
32	341-85111-00-00	. REFLECTOR, FRONT 1	2	
33	92990-05100-00	. WASHER, SPRING	2	
34	95380-05600-00	. NUT	2	
35	(256-23162-60-00)	COVER, RFLCTR STAY	2	
36	(248-23121-01-F3)	COVER, UPPER 1	1	
	(291-23121-60-52)	COVER, UPPER 1	1	
37	(248-23131-01-F3)	COVER, UPPER 2	1	
	(291-23131-60-52)	COVER, UPPER 2	1	
-1	(314-23101-20-00)	FRONT FORK ASSEMBLY	1	
	(316-23100-60-71)	FRONT FORK ASSEMBLY	1	
	(316-23101-20-00)	FRONT FORK ASSEMBLY	1	

STEERING

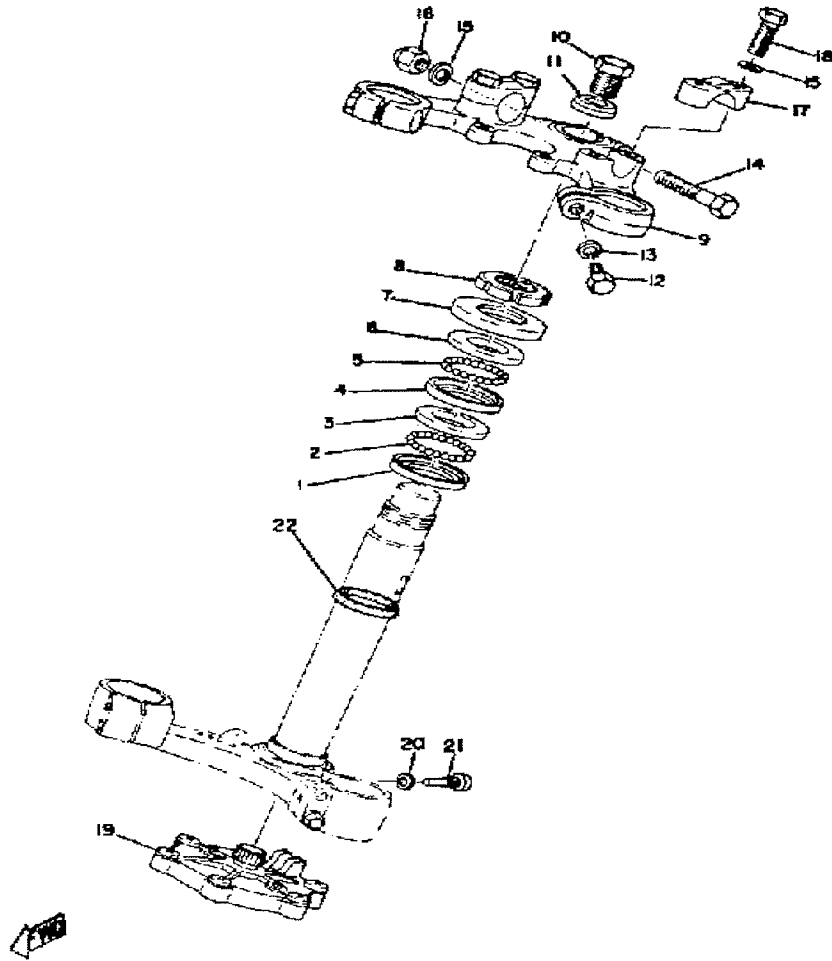

Ref. No.	Part Number	Description	Qty	Remarks
1	156-23411-00-00	RACE, BALL 1	1	
2	93501-04011-00	BALL	19	
3	156-23412-00-00	RACE, BALL 2	1	
4	22F-23412-01-00	RACE, BALL 2	1	
5	93503-16010-00	BALL	22	
6	22F-23411-01-00	RACE, BALL 1	1	
7	122-23416-00-00	COVER, BALL RACE 2	1	
8	90179-25033-00	NUT	1	
9	(248-23435-03-33)	CROWN, HANDLE	1	
10	90101-14113-00	BOLT (214-23451-10)	1	
11	90209-14022-00	WASHER, SPEC'L SHAP (214-23443-00)	1	
12	97013-10030-00	BOLT (8J7) (97303-10030)	2	
13	92990-10100-00	WASHER, SPRING	2	
14	97313-08045-00	BOLT	1	
15	92990-08100-00	WASHER	5	
16	95303-08800-00	NUT (CROWN) (95301-08800) ..	1	
17	(315-23441-00-93)	HOLDER, HANDLE UPR	2	
	401-23441-00-98	HOLDER, HANDLE UPR	2	
18	97313-08030-00	BOLT, HEXAGON	4	
19	5G2-23490-00-00	HDLBR SMY DMPR ASSEMBLY	1	
20	92995-06100-00	WASHER, SPRING	1	
21	(214-23492-00-00)	BOLT	1	
22	164-23462-00-00	SEAL, STEERING	1	

OIL TANK

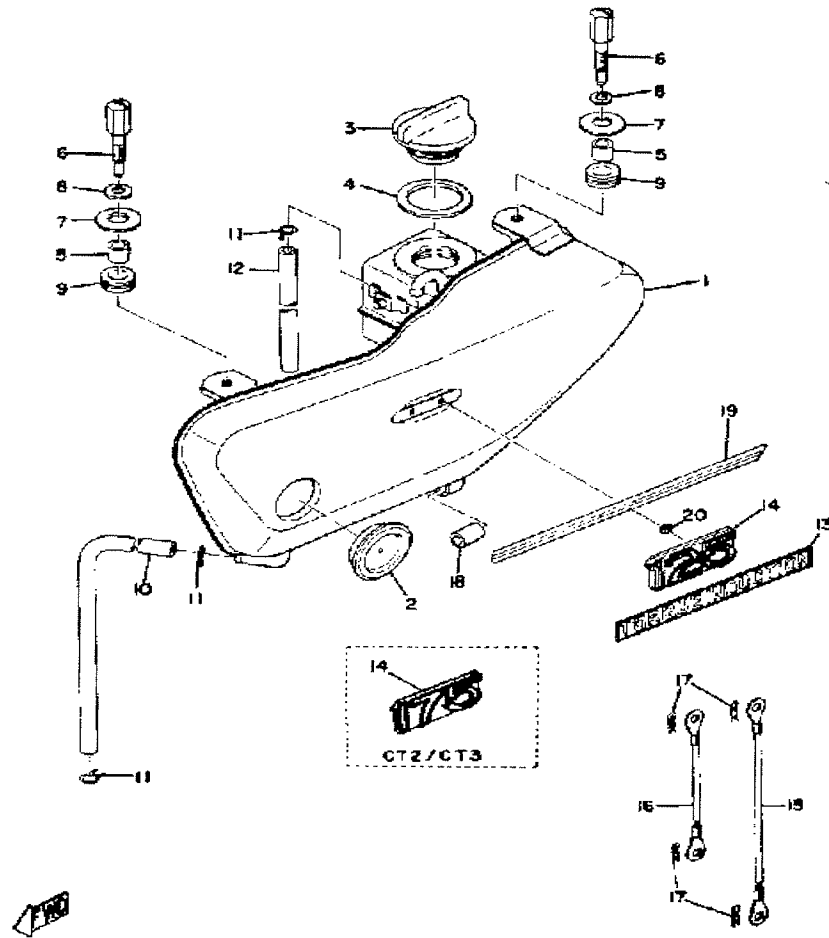

Ref. No.	Part Number	Description	Qty	Remarks
1	(315-21705-01-63)	OIL TANK ASSEMBLY	1	
	(315-21705-01-71)	OIL TANK ASSEMBLY	1	
	(315-21705-01-F3)	OIL TANK ASSEMBLY	1	
	(315-21705-01-M2)	OIL TANK ASSEMBLY	1	
2	214-21761-00-00	. GAUGE, LEVEL	1	
3	214-21771-00-00	BODY, CAP	1	
4	90430-29114-00	GASKET	1	
5	90387-065L7-00	COLLAR (51L) (214-21633-00)	2	
6	97011-06025-00	BOLT (97001-06025)	2	
	98511-06025-00	SCREW PAN HEAD (92501-06025)	2	
7	90201-06067-00	WASHER, PLATE	2	
8	92995-06100-00	WASHER, SPRING	2	
9	90480-14023-00	GROMMET	2	
10	90445-09111-00	HOSE	1	
11	90467-08003-00	CLIP	3	
12	90446-09232-00	HOSE	1	
13	(308-21787-00-00)	EMBLEM 7	1	
	(308-21787-01-00)	EMBLEM 7	1	
14	(314-21786-00-00)	EMBLEM 6	1	
	(315-21786-00-63)	EMBLEM 6	1	
	(315-21786-01-63)	EMBLEM 6 0 0	1	3215 BRILLIANT RED
	(316-21786-00-00)	EMBLEM 6	1	
	(317-21786-01-71)	EMBLEM 6	431	7015 MANDARIN ORNG
15	(248-21775-00-00)	BOLT, TANK FITTING	1	
16	(261-21775-00-00)	BOLT, TANK FITTING	1	
17	90468-10050-00	CLIP	4	
18	437-21779-00-00	DAMPER, LOCATING 2	1	

CONTINUED ON NEXT FRAME ►

OIL TANK

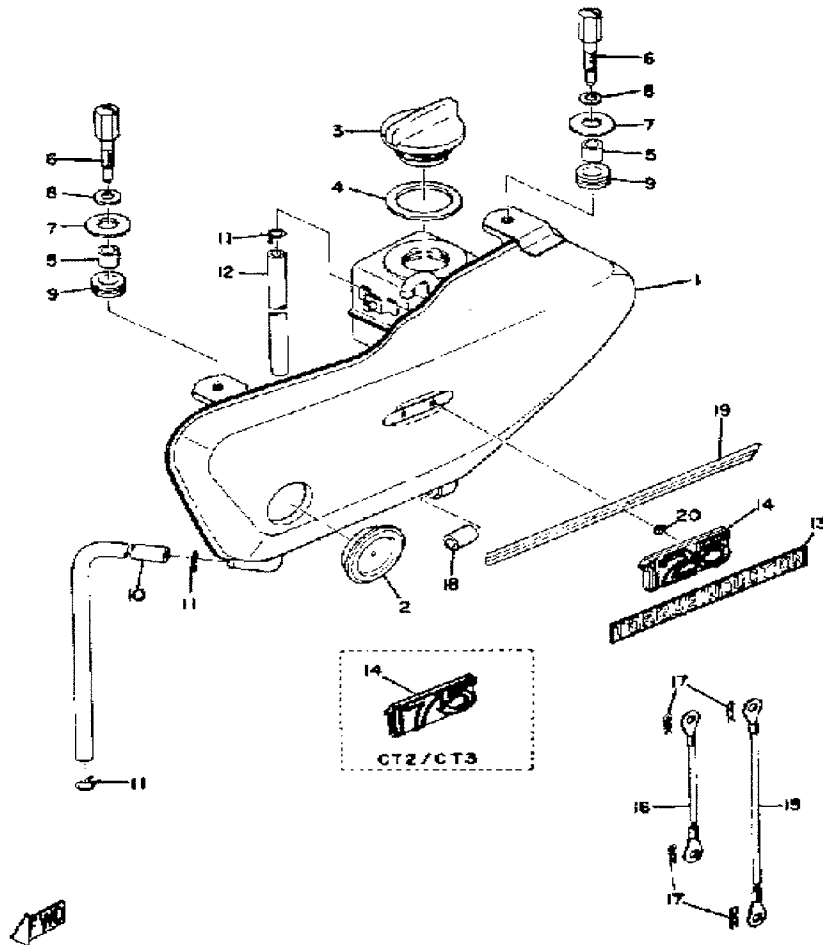

Ref. No.	Part Number	Description	Qty	Remarks
19	(315-21799-00-33)	GRAPHIC	1	YAMAHA BLK
	(315-21799-00-36)	GRAPHIC	1	WHITE
20	(304-21791-00-00)	NUT	2	

FUEL TANK

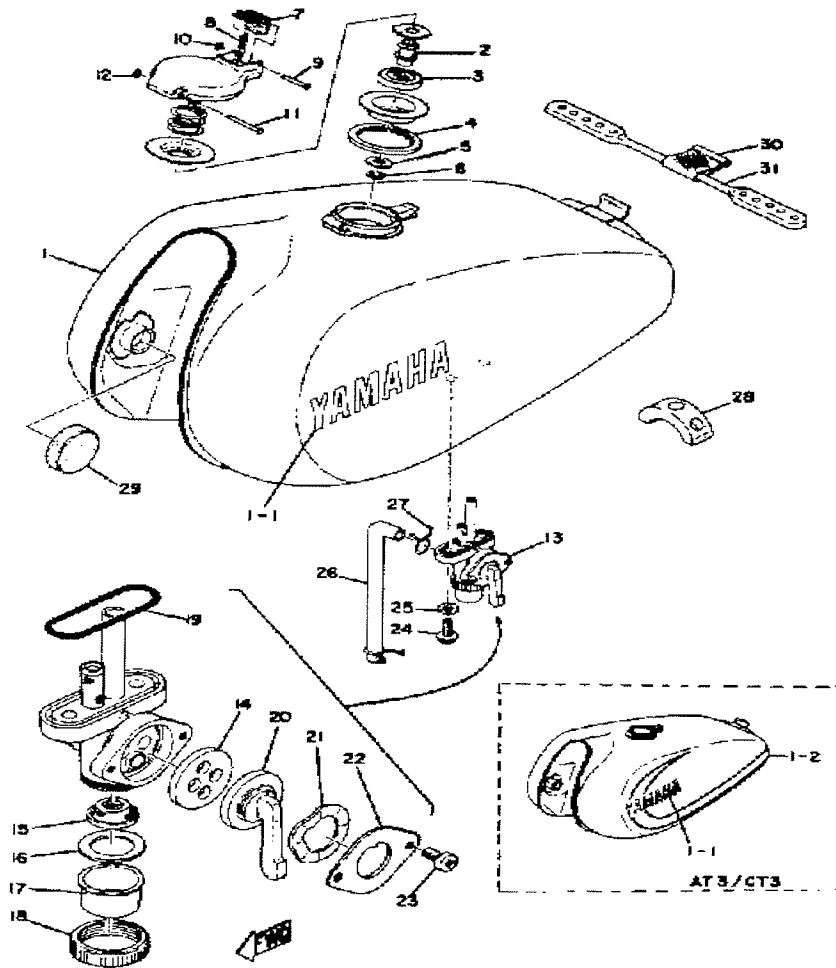

Ref. No.	Part Number	Description	Qty	Remarks
1	(315-24110-00-01)	FUEL TANK	1	
	(315-24110-00-02)	FUEL TANK	1	
	(315-24110-00-63)	FUEL TANK	1	
	(315-24110-00-71)	FUEL TANK	1	
2	(308-24642-00-00)	GASKET, CAP 2	1	
3	(308-24641-00-00)	GASKET, CAP 1	1	
4	308-24612-00-00	GASKET, CAP	1	
5	92990-08200-00	WASHER, PLAIN	1	
6	99009-06600-00	CIRCLIP	1	
7	308-24628-00-00	HOOK	1	
8	(90501-07301-00)	SPRING, COMPRESSION	1	
9	90249-03088-00	PIN, SPEC'L SHAPE (308-24624-00)	1	
10	93430-02001-00	CIRCLIP	1	
11	90249-03087-00	PIN, SPEC'L SHAPE (308-24623-00)	1	
12	93430-02001-00	CIRCLIP	1	
13	498-24500-01-00	FUEL COCK ASSEMBLY 1 (214-24500-02)	1	
14	214-24523-00-00	VALVE	1	
15	214-24515-00-00	NET, FILTER 2	1	
16	214-24522-00-00	GASKET	1	
17	214-24521-00-00	CUP, FILTER	1	
18	214-24531-00-00	NUT	1	
19	214-24512-00-00	GASKET	1	
20	(214-24524-01-00)	LEVER, COCK	1	
21	90206-18025-00	WASHER, WAVE	1	
22	(214-24525-00-00)	PLATE, LVR FITTING	1	
23	214-24535-00-00	SCREW, PAN HEAD	2	
24	90149-06011-00	SCREW	2	

CONTINUED ON NEXT FRAME ►

FUEL TANK

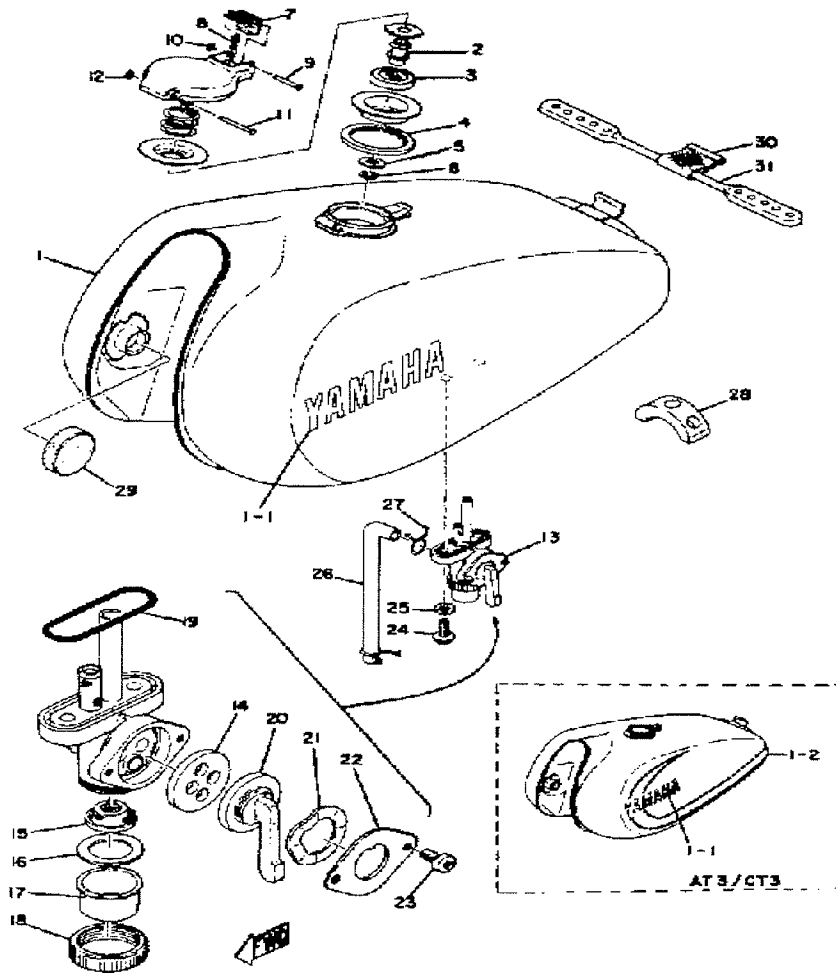

Ref. No.	Part Number	Description	Qty	Remarks
25	90202-05187-00	WASHER, PLATE	2	
26	214-24311-00-00	PIPE, FUEL 1 (7-190)	1	
27	90467-10008-00	CLIP	2	
28	(248-24183-00-00)	DAMPER, LOCATING 3	1	
29	278-24181-00-00	DAMPER, LOCATING 1	2	
30	214-24173-00-00	BAND, TNK FITTING 1	1	
31	248-24173-00-00	BAND, TNK FITTING 1	1	
-1	(308-24610-00-00)	CAP ASSEMBLY	1	
1-1	(304-24161-00-00)	EMBLEM 1	2	
	322-24161-00-00	. EMBLEM 1	2	
1-2	(314-24244-00-00)	GRAPHIC, FUEL TNK 1	1	
	(314-24245-00-00)	GRAPHIC, FUEL TNK 2	1	

SEAT - CARRIER

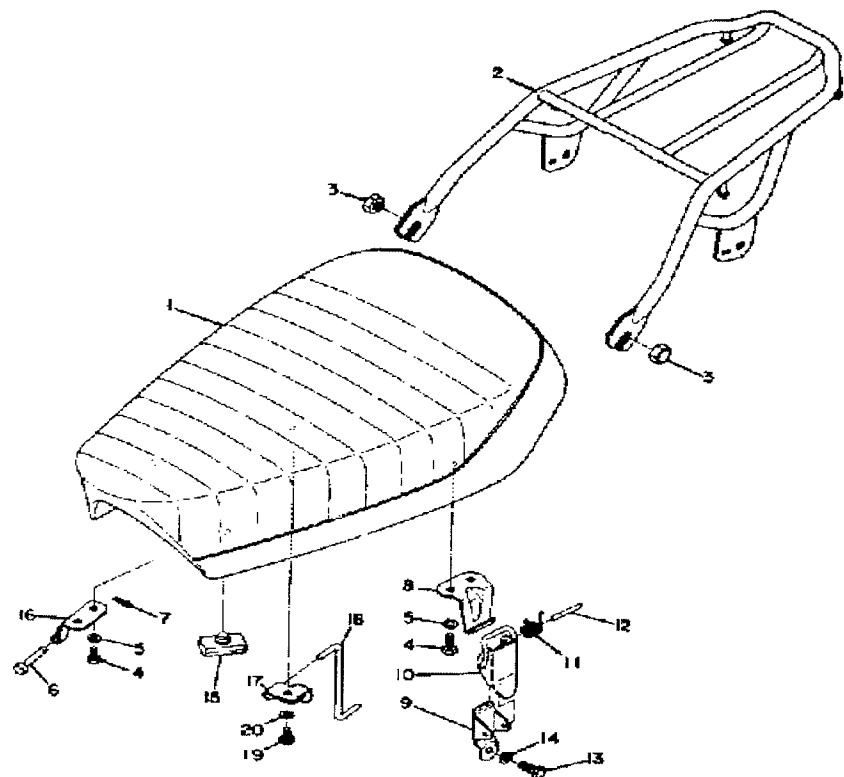

Ref. No.	Part Number	Description	Qty	Remarks
1	(314-24710-00-00)	SINGLE SEAT ASSEMBLY	1	
2	(444-24810-00-00)	CARRIER AT/CT	1	
3	95303-10800-00	NUT (CROWN) (92803-10700)	2	
4	97013-06012-00	BOLT	6	
5	92995-06100-00	WASHER, SPRING	6	
6	91701-05055-00	PIN, CLEVIS	2	
7	90468-10050-00	CLIP	2	
8	(214-24728-00-33)	BRACKET, SEAT	1	
9	214-24718-00-00	BRACKET, SEAT	1	
10	214-24776-00-33	LEVER, SEAT	1	
11	90508-10012-00	SPRING, TORSION	1	
12	90249-04068-00	PIN, SPECL SHAPE	1	
13	97011-06010-00	BOLT	1	
14	92990-06200-00	WASHER	1	
15	214-24724-00-00	DAMPER, SEAT	2	
	214-24724-00-00	DAMPER, SEAT	3	
16	(315-24726-00-00)	HINGE, SEAT	2	
17	(278-24748-00-00)	BRACKET, SEAT	1	
18	(276-24768-00-00)	STOPPER	1	
19	97013-06012-00	BOLT	1	
20	92995-06100-00	WASHER, SPRING	1	
1-1	(444-24711-00-00)	COVER, SINGLE SEAT	1	

FRONT WHEEL

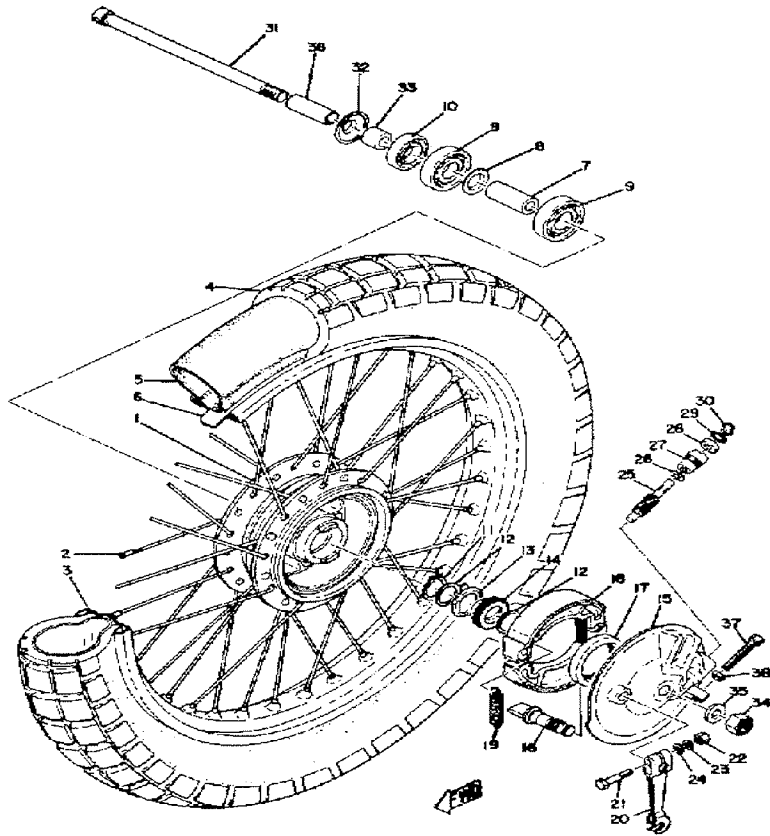

(AT2/3)

TIRE SIZE (FRONT) (TYPE TREAD)	3.00-18 4PR
(REAR) (TYPE TREAD)	3.25-18 4PR
TIRE PRESSURE (LBS.) (FRONT)	14
(REAR)	17

(CT2/3)

TIRE SIZE (FRONT) (TYPE TREAD)	3.25-18 4PR
(REAR) (TYPE TREAD)	3.50-18 4PR
TIRE PRESSURE (LBS.) (FRONT)	14
(REAR)	17

Ref. No.	Part Number	Description	Qty	Remarks
1	(248-25111-00-38)	HUB, FRONT	1	
2	(248-25104-00-00)	SPOKE SET, FRONT	1	
3	(94416-18018-00)	RIM 1.60X 8	1	
	94414-18007-00	RIM (1.40X18)	1	
4	(94130-18322-00)	300X18 YOKO Y6 0	1	
	(94132-18320-00)	325X18 YOKO Y6 0	1	
5	94230-18084-00	TUBE	1	
6	94325-18043-00	BAND, RIM	1	
7	90560-12261-00	SPACER	1	
8	109-25315-00-00	FLANGE, SPACER	1	
9	93306-30103-00	BEARING (B6301Z)	2	
10	93102-18008-00	OIL SEAL	1	
11	99009-20400-00	CIRCLIP	1	
12	90201-20269-00	WASHER, PLATE	2	
13	183-25149-00-00	CLUTCH, METER	1	
14	(248-25135-00-00)	GEAR, DRIVE	1	
	301-25135-00-00	GEAR, DRIVE	1	
15	(315-25121-00-00)	PLATE, BRAKE SHOE	1	
16	122-25351-02-00	CAMSHAFT	1	
17	93105-47007-00	OIL SEAL	1	
18	296-W2536-00-00	BRAKESHOE SET-2PCS	2	
19	90506-16150-00	SPRING, TENSION (102-25333-00)	2	
20	137-25155-00-00	LEVER, CAMSHAFT 1	1	
21	97313-06030-00	BOLT, HEXAGON	1	
22	95380-06600-00	NUT	1	
23	92995-06100-00	WASHER, SPRING	1	
24	92990-06200-00	WASHER	1	
25	214-25138-00-00	GEAR, METER	1	

CONTINUED ON NEXT FRAME ►

FRONT WHEEL

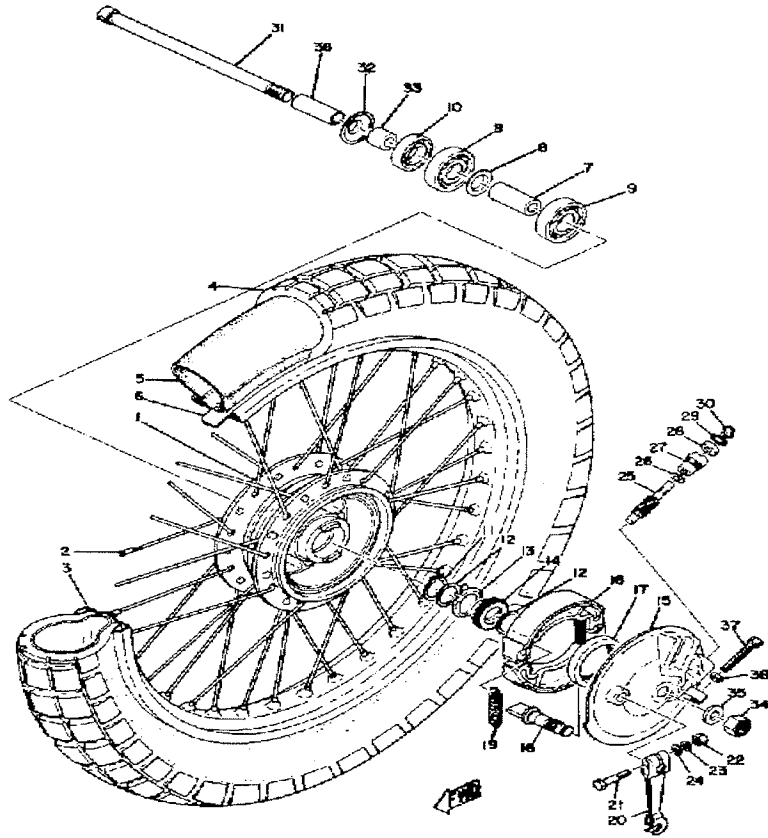

Ref. No.	Part Number	Description	Qty	Remarks
25	301-25138-00-00	GEAR, METER	1	
26	90201-07076-00	WASHER, PLATE	1	
27	109-25136-00-00	BUSH	1	
28	93104-07003-00	OIL SEAL	1	
29	93210-14104-00	O-RING	1	
30	102-25137-00-00	RING, STOP	1	
31	401-25181-01-00	AXLE, WHEEL	1	
32	2K5-25118-00-00	COVER, HUB DUST	1	
33	90387-12095-00	COLLAR	1	
34	95303-12600-00	NUT	1	
35	92990-12200-00	WASHER, PLAIN	1	
36	90387-12100-00	COLLAR	1	
37	90123-06011-00	BOLT	1	
38	90179-06143-00	NUT, SPEC'L SHAPE	1	
2-1	(248-25196-90-00)	SPOKE SET, INNER 1	1	
	(248-25197-90-00)	SPOKE SET, OUTER 1	1	

(AT2/3)

TIRE SIZE (FRONT) (TYPE TREAD)	3.00-18 4PR
(REAR) (TYPE TREAD)	3.25-18 4PR
TIRE PRESSURE (LBS.) (FRONT)	14
(REAR)	17

(CT2/3)

TIRE SIZE (FRONT) (TYPE TREAD)	3.25-18 4PR
(REAR) (TYPE TREAD)	3.50-18 4PR
TIRE PRESSURE (LBS.) (FRONT)	14
(REAR)	17

REAR WHEEL

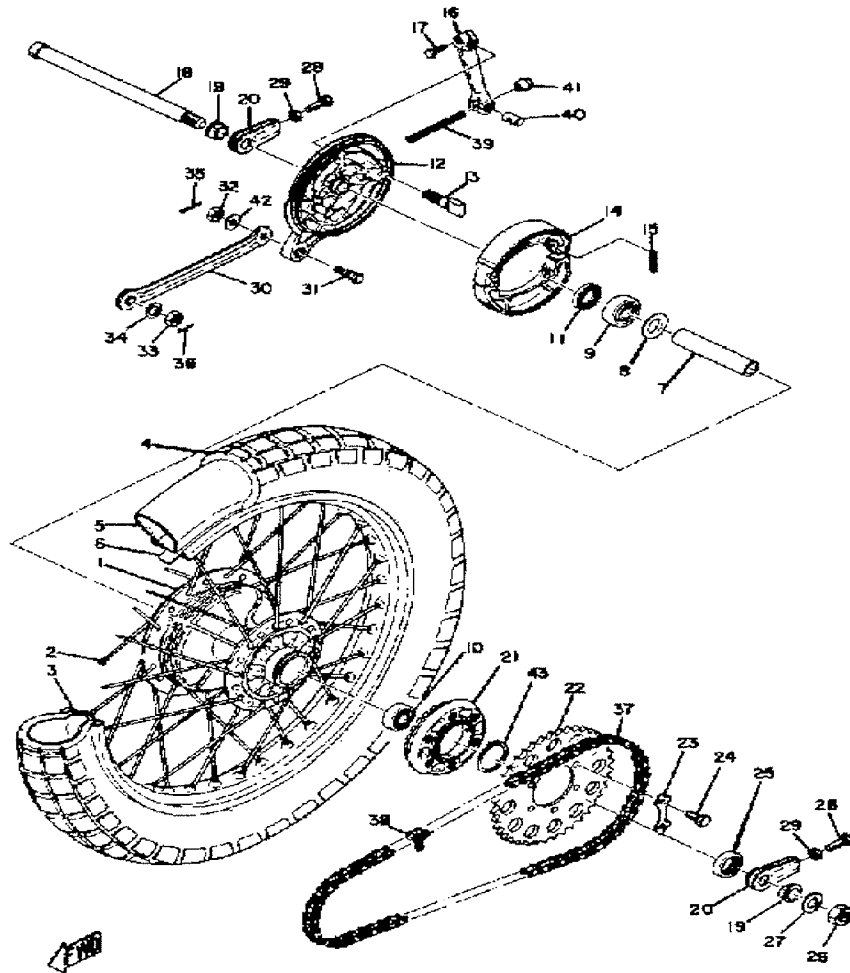

Ref. No.	Part Number	Description	Qty	Remarks
1	(443-25311-00-00)	HUB, REAR	1	
2	(248-25391-90-00)	SPOKE SET, INNER 1	1	
	(248-25396-90-00)	SPOKE SET, INNER 2	1	
	(248-25397-90-00)	SPOKE SET, OUTER 2	1	
	248-25304-00-00	SPOKE SET, REAR	1	
3	(94416-18040-00)	RIM 1.60X 8	1	
	94418-18171-00	RIM 1.85X 8	1	
4	(94132-18320-00)	325X18 YOKO Y6 0	1	
	(94135-18319-00)	350X18 YOKO Y6 0	1	
5	94230-18084-00	TUBE	1	
	94235-18085-00	TUBE	1	
6	94325-18043-00	BAND, RIM	1	
7	90560-15313-00	SPACER	1	
8	146-25115-00-00	FLANGE, SPACER 1	1	
9	93306-20211-00	BEARING (6202SH2-C3)	1	
10	93306-30202-00	BEARING	1	
11	93104-22018-00	OIL SEAL	1	
12	437-25026-10-35	BRAKE SHOE PLT ASSEMBLY ASSY (437-25320-10-38)	1	
13	2RH-25351-00-00	CAMSHAFT	1	
14	183-W2536-00-00	BRAKE SHOE SET	2	
15	90506-17328-00	SPRING, TENSION	2	
16	214-25355-00-00	LEVER, CAMSHAFT	1	
17	97011-06020-00	BOLT	1	
18	401-25381-00-00	AXLE, WHEEL (2R7-25381-00)	1	
19	90387-15115-00	COLLAR	2	
20	248-25388-00-00	PULLER, CHAIN 1	2	
21	248-25364-00-00	DAMPER	1	

CONTINUED ON NEXT FRAME ►

REAR WHEEL

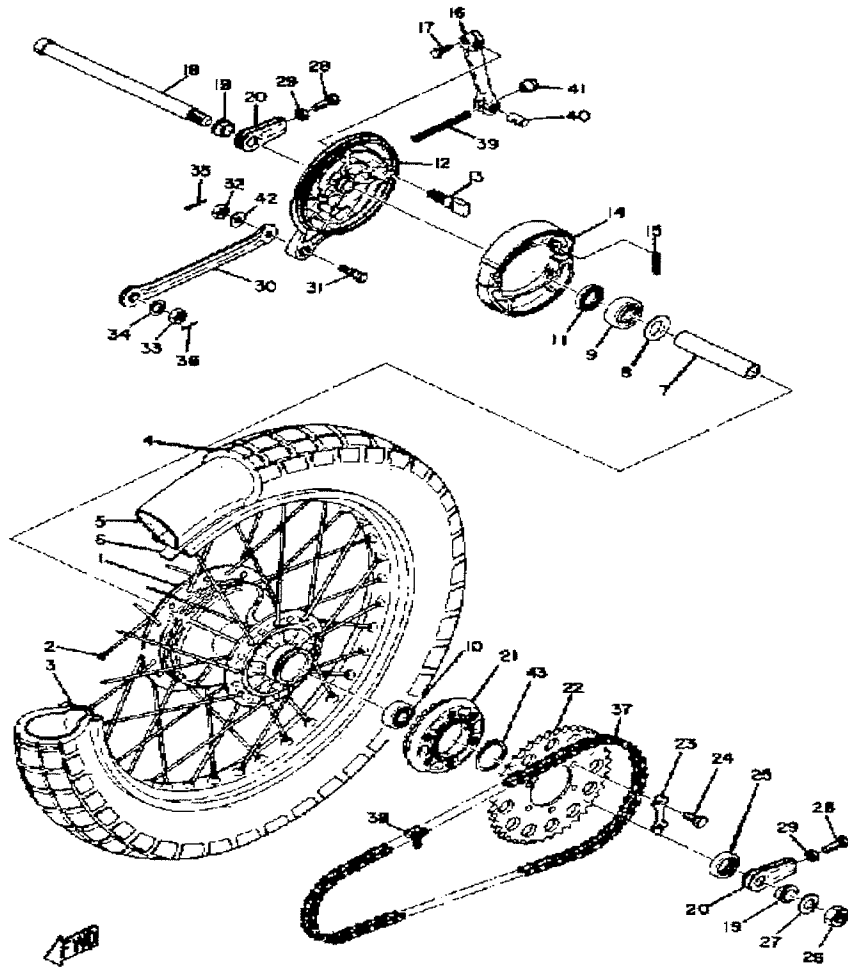

Ref. No.	Part Number	Description	Qty	Remarks
22	248-25445-11-00	SPROCKET, DRVN45T	1	U.R.
	4V1-25444-10-00	SPROCKET, DRVN 44T	1	U.R.
23	22W-25412-00-00	WASHER	3	
24	97313-08012-00	BOLT	6	
25	93106-26005-00	OIL SEAL	1	
26	95312-14600-00	NUT	1	CT2)
27	92901-14100-00	WASHER, SPRING	1	CT2)
28	90101-08699-00	BOLT	2	
29	95303-08700-00	NUT	2	
30	(248-25371-00-00)	BAR, TENSION	1	
31	90109-08063-00	BOLT	1	
32	95303-08700-00	NUT	1	
33	95303-10700-00	NUT	1	
34	92990-10200-00	WASHER, PLAIN	1	
35	91490-20020-00	PIN, COTTER	1	
36	91401-25020-00	PIN, COTTER	1	
37	94580-30114-00	428-110L (94524-28114)	1	
38	94680-30001-00	. CHAIN JOINT	1	
39	90501-10245-00	SPRING, COMPRESSION	1	
40	90249-12008-00	PIN	1	
41	90179-06411-00	NUT	1	
42	92990-08100-00	WASHER	1	
43	93410-52061-00	CIRCLIP	1	

HANDLE - WIRE

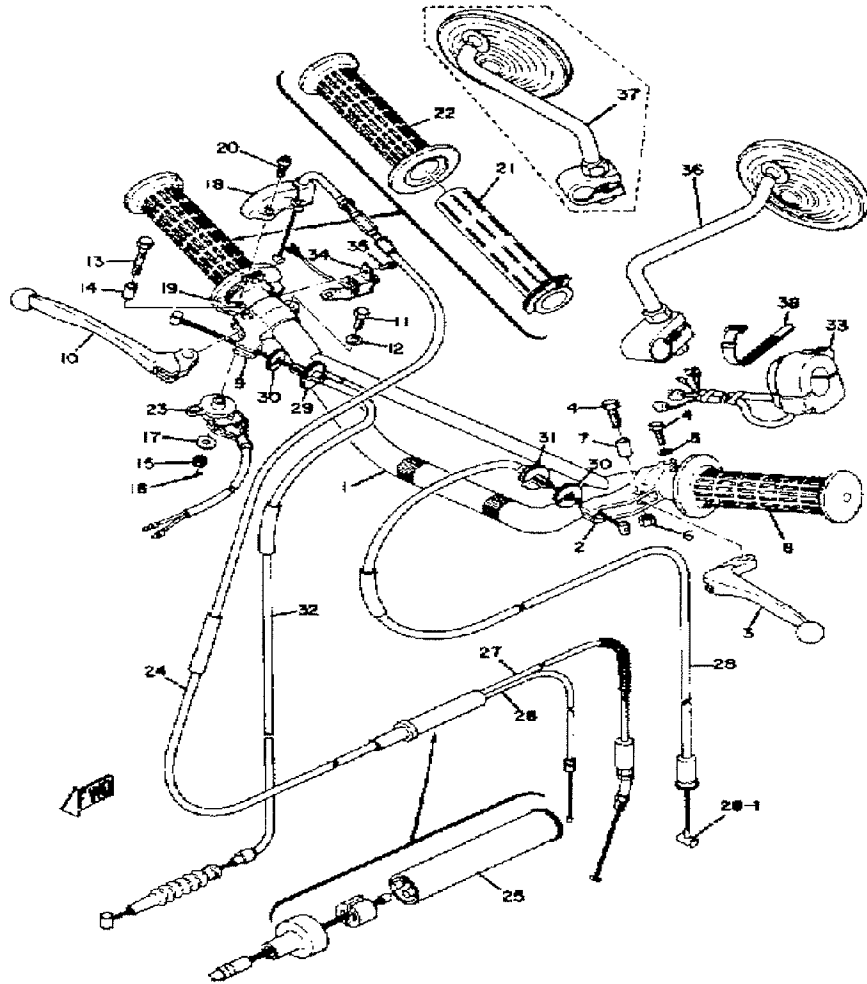

Ref. No.	Part Number	Description	Qty	Remarks
1	438-26111-00-00	HANDLEBAR	1	
2	214-82911-01-00	. HOLDER, LEVER 1	1	
3	214-83912-00-00	. LEVER 1	1	
4	97011-06020-00	. BOLT	2	
5	92995-06100-00	. WASHER, SPRING	1	
6	95380-06700-00	. NUT	1	
7	214-83913-00-00	. COLLAR, LEVER 1	1	
8	214-26241-00-00	GRIP LH	1	
9	233-82921-31-00	. HOLDER, LEVER 2	1	
10	233-83922-30-00	. LEVER R	1	
11	97011-06020-00	. BOLT	1	
12	92995-06100-00	. WASHER, SPRING	1	
13	90109-05197-00	. BOLT (233-81915-01)	1	
14	214-83913-00-00	. COLLAR, LEVER 1	1	
15	95301-05900-00	. NUT, SLOTTED	1	
16	91401-12018-00	. PIN, COTTER	1	
17	92990-05200-00	. WASHER, PLAIN	1	
18	214-26281-01-00	CAP, GRIP UPPER	1	
19	214-26282-01-00	CAP, GRIP LOWER	1	
	248-26282-00-00	CAP, GRIP LOWER	1	
20	98501-05018-00	SCREW, PAN HEAD	2	
21	214-26243-00-00	TUBE, THRTL GUIDE	1	
22	1A0-26242-01-00	GRIP (RIGHT)	1	
	214-26242-00-00	GRIP RH	1	
23	232-83980-30-00	STOP SWITCH ASSEMBLY	1	
24	248-26311-01-00	CABLE, THROTTLE 1	1	
25	214-26261-00-00	CONNECTOR, CABLE	1	
26	248-26312-00-00	CABLE, THROTTLE 2	1	
27	248-26321-00-00	CABLE, PUMP	1	

CONTINUED ON NEXT FRAME ►

HANDLE - WIRE

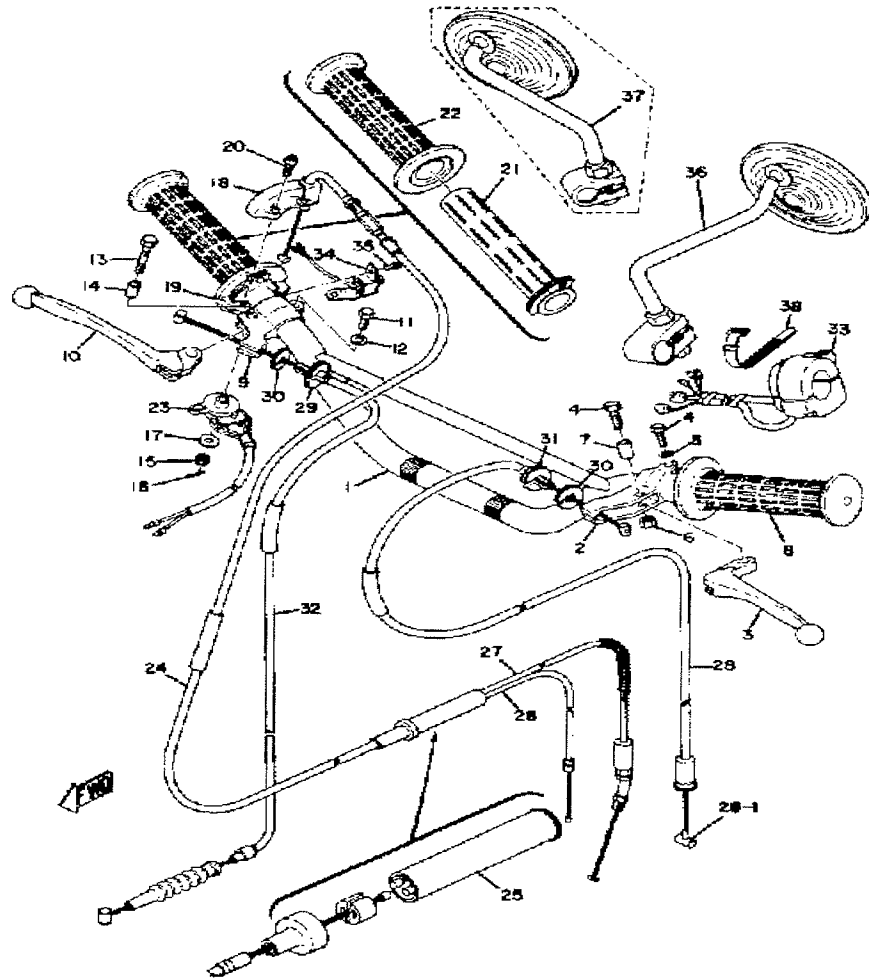

Ref. No.	Part Number	Description	Qty	Remarks
28	248-26335-00-00	CABLE, CLUTCH	1	
29	90123-08046-00	BOLT	1	
30	90179-08148-00	NUT	2	
31	90123-08046-00	BOLT	1	
32	248-26341-00-00	CABLE, BRAKE	1	
	315-26341-00-00	CABLE, BRAKE	1	
33	233-83973-00-94	SWITCH, HANDLE 3 (3)	1	
34	261-83976-00-00	SWITCH, HANDLE 1	1	
35	98580-03008-00	SCREW, PAN HEAD	2	
36	253-26290-10-00	MIRROR ASSEMBLY LH	1	
37	253-26290-00-00	MIRROR ASSEMBLY	1	
38	437-83936-01-00	BAND, SWITCH CORD	2	
-1	214-82910-07-00	LEVER HOLDER ASSEMBLY 1 (214-82910-05)	1	
-2	233-82920-32-00	LEVER HOLDER ASSEMBLY 2	1	
28-1	164-26363-00-00	END, CABLE	1	

STAND - FOOTREST - BRAKE PEDAL

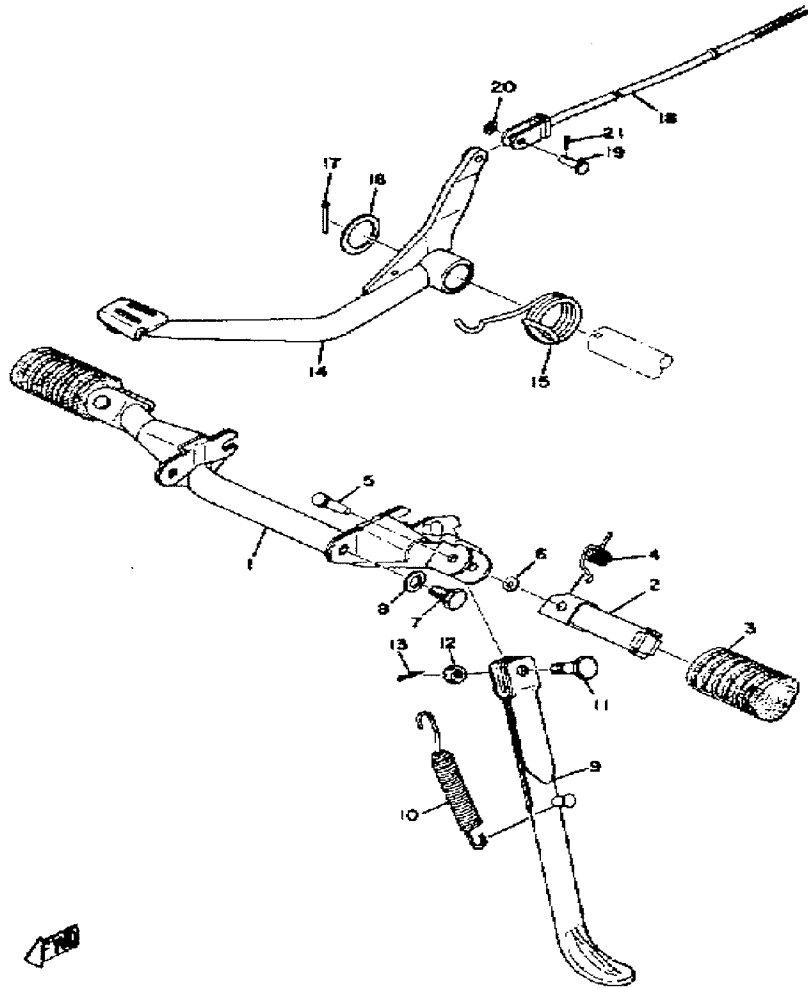

Ref. No.	Part Number	Description	Qty	Remarks
1	(261-27411-00-00)	FOOTREST 1	1	
	248-27411-00-00	FOOTREST 1	1	
2	214-27421-00-00	FOOTREST 2	2	
3	214-27413-00-00	COVER, FOOTREST	2	
4	90508-20023-00	SPRING, TORSION	2	
5	90243-08006-00	PIN	2	
6	90201-06042-00	WASHER, PLATE	2	
7	97021-10018-00	BOLT	2	
8	92990-10100-00	WASHER, SPRING	2	
9	248-27311-01-00	STAND, SIDE	1	
10	90507-29004-00	SPRING, TENSION (214-27316-00)	1	
11	90102-10006-00	BOLT, WITH HOLE (278-27317-00)	1	
12	95303-10900-00	NUT, SLOTTED	1	
13	91490-20025-00	PIN, SPLIT	1	
14	248-27211-00-33	PEDAL, BRAKE	1	
15	90508-35070-00	SPRING, TORSION (248-27216-00)	1	
16	90201-25289-00	WASHER, PLATE	1	
17	91401-40040-00	PIN, COTTER	1	
18	248-27231-00-00	ROD, BRAKE	1	
19	90240-06006-00	PIN, CLEVIS	1	
20	92990-06200-00	WASHER	1	
21	91401-25020-00	PIN, COTTER	1	

SPEEDOMETER - TACHOMETER (AT2 - /

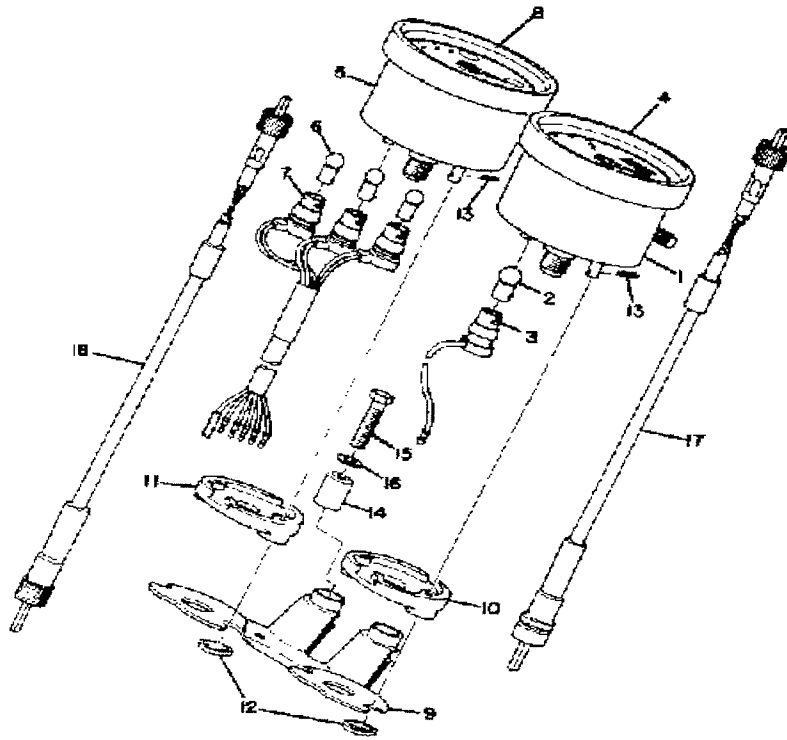

Ref. No.	Part Number	Description	Qty	Remarks
1	(316-83570-40-00)	SPEEDOMETER ASSEMBLY ..	1	
2	123-83516-21-00	. BULB (12V-3.4W)	1	
3	(235-83536-21-00)	SOCKET, METER	1	
4	336-83513-00-00	. DAMPER	1	
5	(316-83540-00-00)	TACHOMETER ASSEMBLY ...	1	
6	123-83516-21-00	. BULB (12V-3.4W)	3	
7	(316-83520-00-00)	SOCKET CORD ASSEMBLY ..	1	
8	336-83513-00-00	. DAMPER	1	
9	(275-83519-00-33)	BRACKET, METER	1	
10	214-83523-00-00	DAMPER	1	
11	237-83523-00-00	DAMPER	1	
12	90209-05029-00	WASHER, SPEC'L SHAP (214-83524-00)	4	
13	90468-10050-00	CLIP	4	
14	90385-06001-00	BUSH, SPEC'L RUBBER (214-83528-00)	2	
15	97313-06030-00	BOLT, HEXAGON	2	
16	92990-06200-00	WASHER	2	
17	3J0-83550-00-00	SPEEDOMETER CABLEASSEMBLY	1	
18	3T2-83560-00-00	TACHOMETER CABLE	1	

SPEEDOMETER - TACHOMETER (CT2 - C

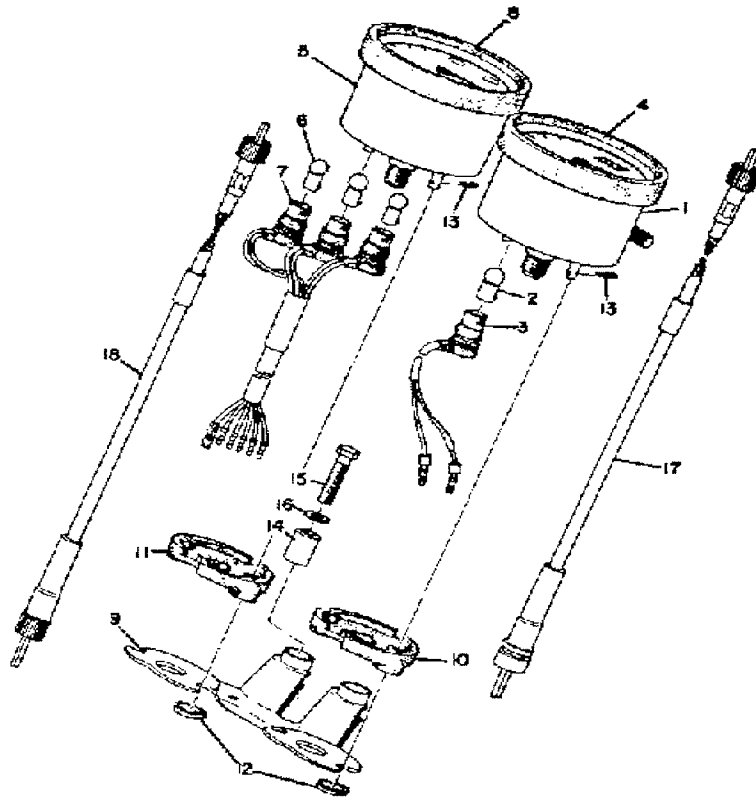

Ref. No.	Part Number	Description	Qty	Remarks
1	(308-83570-30-00)	SPEEDOMETER ASSEMBLY ..	1	
2	122-83516-10-00	. BULB (122-83516-10)	1	
3	(235-83536-21-00)	SOCKET, METER	1	
4	336-83513-00-00	. DAMPER	1	
5	(315-83540-00-00)	TACHOMETER ASSEMBLY	1	
6	122-83516-10-00	. BULB (122-83516-10)	3	
7	(315-83520-00-00)	SOCKET CORD ASSEMBLY ..	1	
8	336-83513-00-00	. DAMPER	1	
9	(275-83519-00-33)	BRACKET, METER	1	
10	214-83523-00-00	DAMPER	1	
11	237-83523-00-00	DAMPER	1	
12	90209-05029-00	WASHER, SPEC'L SHAP (214-83524-00)	4	
13	90468-10050-00	CLIP	4	
14	90385-06001-00	BUSH, SPEC'L RUBBER (214-83528-00)	2	
15	97313-06030-00	BOLT, HEXAGON	2	
16	92990-06200-00	WASHER	2	
17	3J0-83550-00-00	SPEEDOMETER CABLEASSEMBLY	1	
18	3T2-83560-00-00	TACHOMETER CABLE	1	

HEADLIGHT (AT2 - AT3)

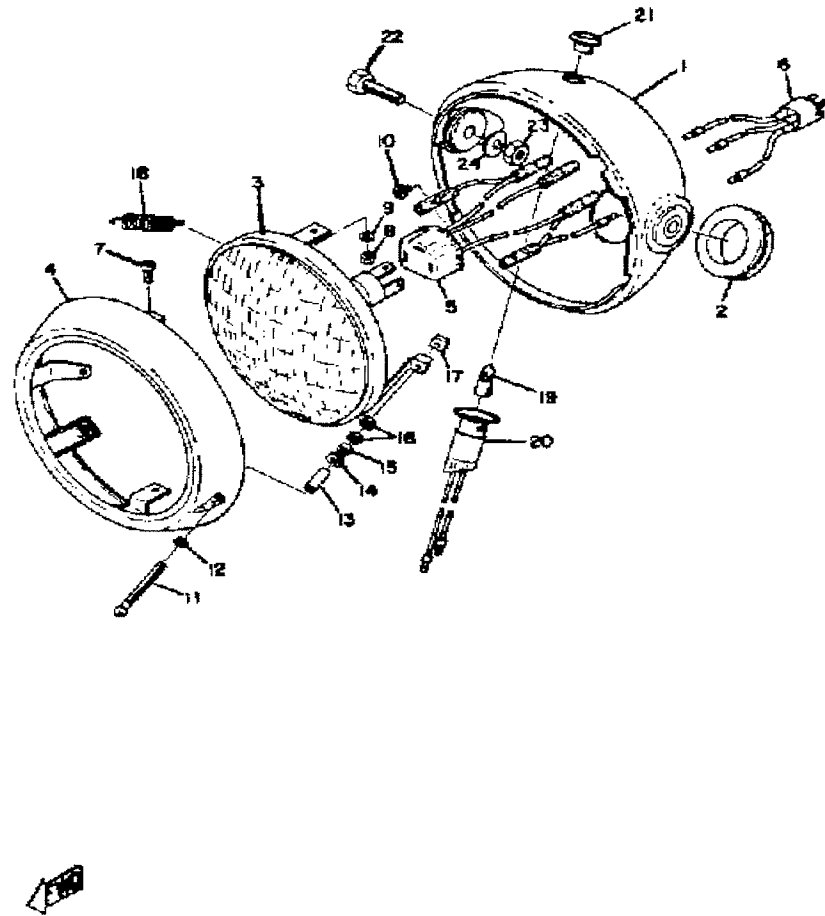

Ref. No.	Part Number	Description	Qty	Remarks
1	(261-84330-60-71)	BODY ASSEMBLY	1	MANDARIN ORANGE
	(261-84330-60-F3)	BODY ASSEMBLY	1	BRIGADE BLUE
2	214-84153-60-00	GROMMET, WIREHERNESS ..	1	
3	261-84320-61-00	LENS ASSEMBLY	1	
4	261-84315-61-00	RIM, HEADLIGHT	1	
5	261-84312-61-00	SOCKET	1	
6	(214-84159-61-00)	CORD, HEADLIGHT	1	
7	98580-04010-00	SCREW, PAN HEAD	2	
8	95301-04700-00	NUT (95302-04700)	2	
9	92901-04100-00	WASHER, SPRING	2	
10	90152-05005-00	SCREW, COUNTERSUNK	1	
11	(198-84331-60-00)	SCREW, RIM ADJUSTING	1	
12	233-84127-60-00	WASHER, SPECIAL	1	
13	233-84133-60-00	COLLAR, SCREW	1	
14	92990-04200-00	WASHER, PLAIN	1	
15	132-84328-60-00	SPACER	1	
16	95301-04700-00	NUT (95302-04700)	2	
17	198-84334-60-00	NUT, ADJUSTING	1	
18	(132-84335-60-00)	SPRING		
19	256-84347-00-00	BULB	1	
20	256-84301-61-00	PILOT LIGHT ASSEMBLY 1 ...	1	
21	256-84357-61-00	BODY, PILOT LIGHT	1	
22	97013-08025-00	BOLT	2	
23	95333-08600-00	NUT	2	
24	92990-08100-00	WASHER	2	
-2	256-84301-61-00	PILOT LIGHT ASSEMBLY 1 ...	1	

HEADLIGHT (CT2 - CT3)

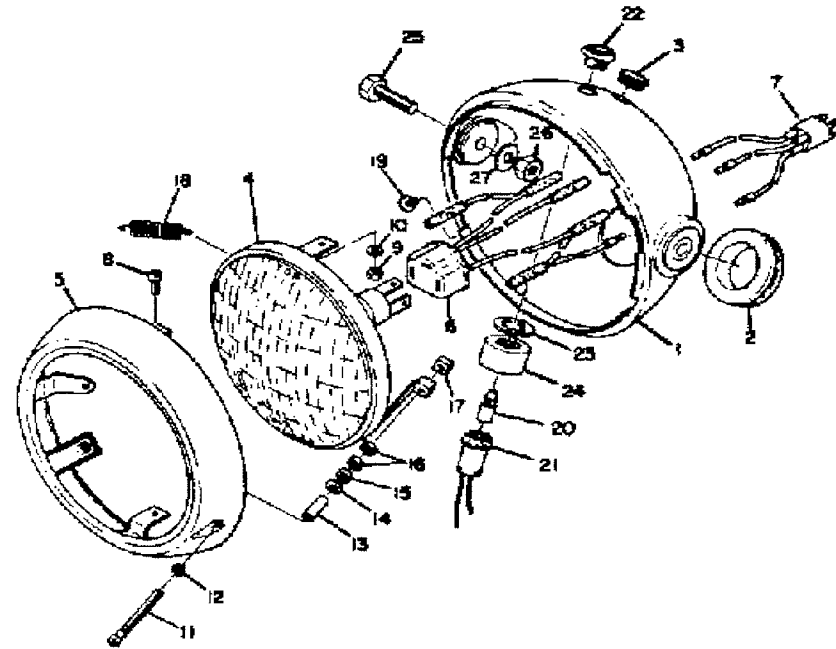

Ref. No.	Part Number	Description	Qty	Remarks
1	(214-84130-61-52)	BODY ASSEMBLY, HEADLIGHT	1	GOLD DUST
	(214-84130-61-63)	BODY ASSEMBLY, HEADLIGHT	1	BRILLIANT RED
2	214-84153-60-00	GROMMET, WIREHERNESS	1	
3	214-84154-60-00	GROMMET	1	
4	251-84120-61-00	LENS ASSEMBLY	1	
5	233-84115-60-00	RIM, HEADLIGHT	1	
6	261-84312-61-00	SOCKET	1	
7	(214-84159-61-00)	CORD, HEADLIGHT	1	
8	98580-05012-00	SCREW, PAN HEAD	2	
9	95380-05600-00	NUT	2	
10	92990-05100-00	WASHER, SPRING	2	
11	90157-04001-00	SCREW, PAN HEAD	1	
12	233-84127-60-00	WASHER, SPECIAL	1	
13	233-84133-60-00	COLLAR, SCREW	1	
14	92990-04200-00	WASHER, PLAIN	1	
15	132-84328-60-00	SPACER	1	
16	95301-04700-00	NUT (95302-04700)	2	
17	198-84334-60-00	NUT, ADJUSTING	1	
18	(132-84335-60-00)	SPRING	1	
19	90152-05005-00	SCREW, COUNTERSUNK	1	
20	104-83517-10-00	BULB (6V-1.5W)	1	
21	256-84301-61-00	PILOT LIGHT ASSEMBLY 1	1	
22	UNA-VAILA-BL-EI	0 0		
23	(92901-12300-00)	WASHER, IN.TOOTH	1	
24	UNA-VAILA-BL-EI	0 0		
25	97013-08025-00	BOLT	2	
26	95333-08600-00	NUT	2	
27	92990-08100-00	WASHER	2	
-2	214-84101-61-00	PILOT LIGHT ASSEMBLY	1	

TAILLIGHT

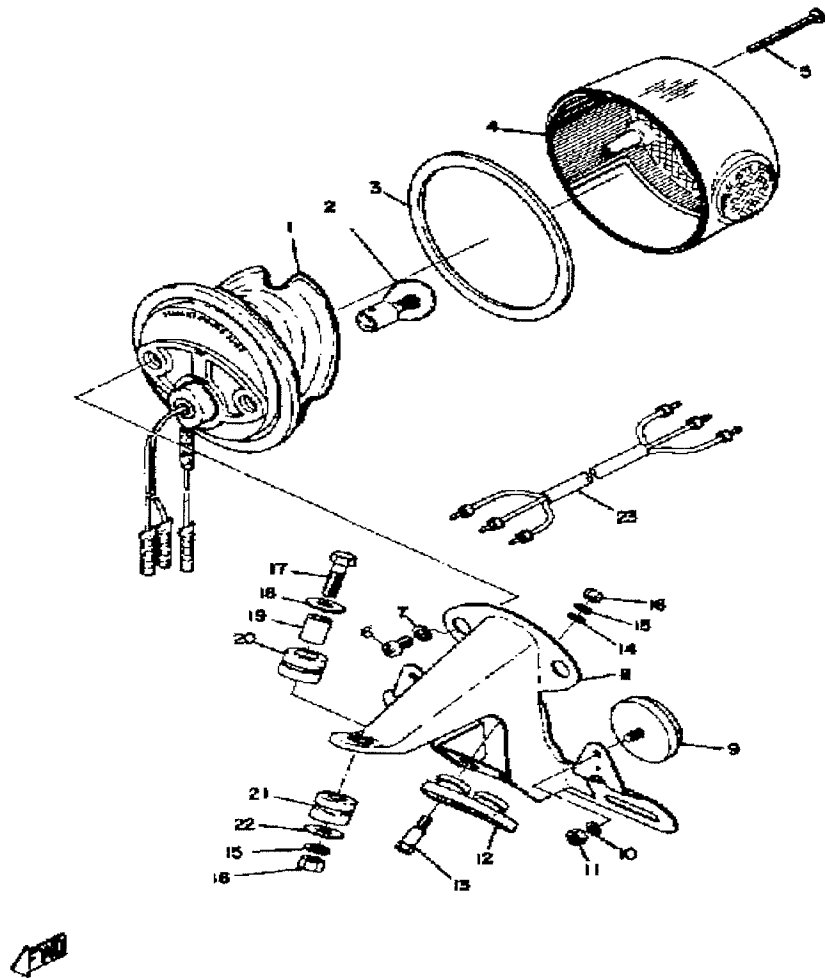

Ref. No.	Part Number	Description	Qty	Remarks
1	(275-84511-61-00)	BASE, TAILLIGHT	1	
2	122-84514-30-00	. BULB	1	
	256-84714-61-00	. BULB (12V-27/8W)	1	
3	275-84523-60-00	. GASKET, LENS	1	
4	(275-84521-60-00)	LENS, TAILLIGHT	1	
5	98501-04050-00	. SCREW, PAN HEAD	3	
6	98580-06010-00	SCREW, PAN HEAD (92503-06010)	2	
7	92995-06100-00	WASHER, SPRING	2	
8	(444-84751-60-20)	BRACKET, LICENSE	1	
9	(278-85111-00-00)	REFLECTOR, FRONT 1	2	
10	92990-05100-00	WASHER, SPRING	2	
11	95380-05600-00	NUT	2	
12	214-84553-01-00	DAMPER	1	
	308-84553-00-00	DAMPER	1	
13	90109-06017-00	BOLT	2	
	90109-06022-00	BOLT (338-84552-00)	2	
14	92990-06200-00	WASHER	2	
15	92995-06100-00	WASHER, SPRING	3	
16	95380-06600-00	NUT	3	
17	97013-06035-00	BOLT	1	
	97313-06040-00	BOLT, HEXAGON	1	
18	90209-06095-00	WASHER, SPEC'L SHAP (102-28323-00)	1	
19	90387-07039-00	COLLAR (275-84557-00)	1	
	90387-07393-00	COLLAR (308-84557-00)	1	
20	(90480-14106-00)	GROMMET	1	
	90480-14023-00	GROMMET	1	
21	90480-14104-00	GROMMET	1	

CONTINUED ON NEXT FRAME ►

TAILLIGHT

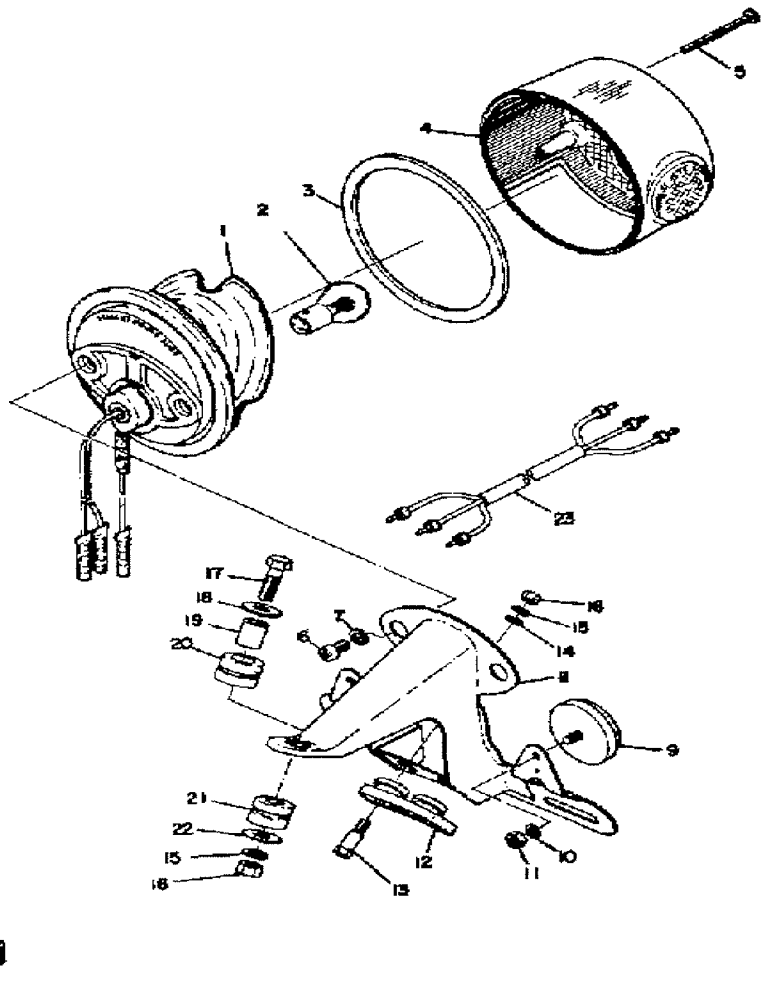

Ref. No.	Part Number	Description	Qty	Remarks
22	90201-06067-00	WASHER, PLATE	1	
23	251-84517-60-00	CORD, TAILLIGHT	1	
-1	(275-84510-61-00)	TAILLIGHT UNIT ASSEMBLY ..	1	
	256-84710-61-00	TAILLIGHT UNIT ASSEMBLY ..	1	

FLASHER LIGHT

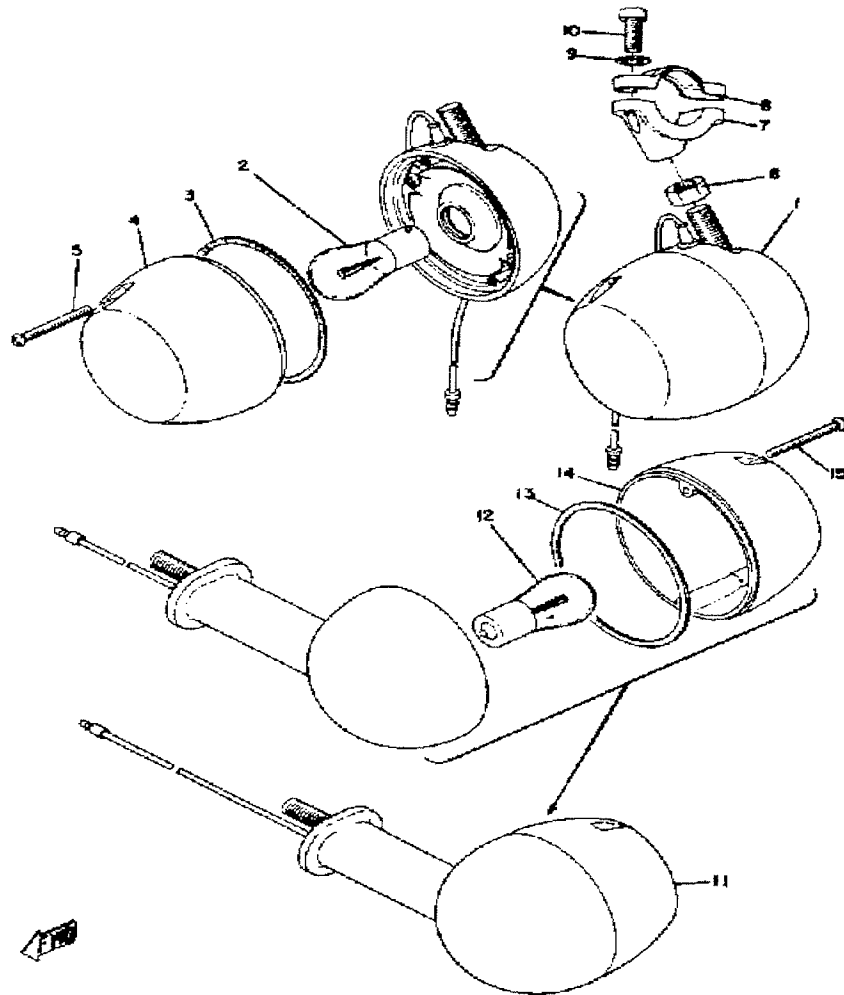

Ref. No.	Part Number	Description	Qty	Remarks
1	(261-83310-71-93)	FRT FLSHR LITE ASSEMBLY	1	AMBER
	275-83310-60-93	FRT FLSHR LITE ASSEMBLY (275-83320-60-93)	1	
2	115-83311-60-00	. BULB, FLASHER	2	
	256-83311-70-XX	. BULB, TS 12V27W	2	
3	183-83313-70-00	. GASKET, FLSHR LENS	2	
4	183-83312-70-00	. LENS, FLASHER	2	AMBER
5	183-83333-71-00	. SCREW, LENS FITTING	4	
6	95303-08700-00	NUT	2	
7	275-83318-00-00	STAY, FLASHER 1	2	
8	275-83328-00-00	STAY, FLASHER 2	2	
9	92901-06300-00	WASHER, IN.TOOTH	4	
10	98503-06014-00	SCREW, PAN HEAD (92502-06016)	4	
11	(251-83340-65-93)	R FLSHR LITE ASSEMBLY	1	
	(261-83340-76-93)	R FLSHR LITE ASSEMBLY	1	
12	115-83311-60-00	. BULB, FLASHER	2	
	256-83311-70-XX	. BULB, TS 12V27W	2	
13	183-83313-70-00	. GASKET, FLSHR LENS	2	
14	211-83332-75-00	. LENS, FLASHER	2	
15	183-83333-71-00	. SCREW, LENS FITTING	4	

ELECTRICAL (AT2 - AT3)

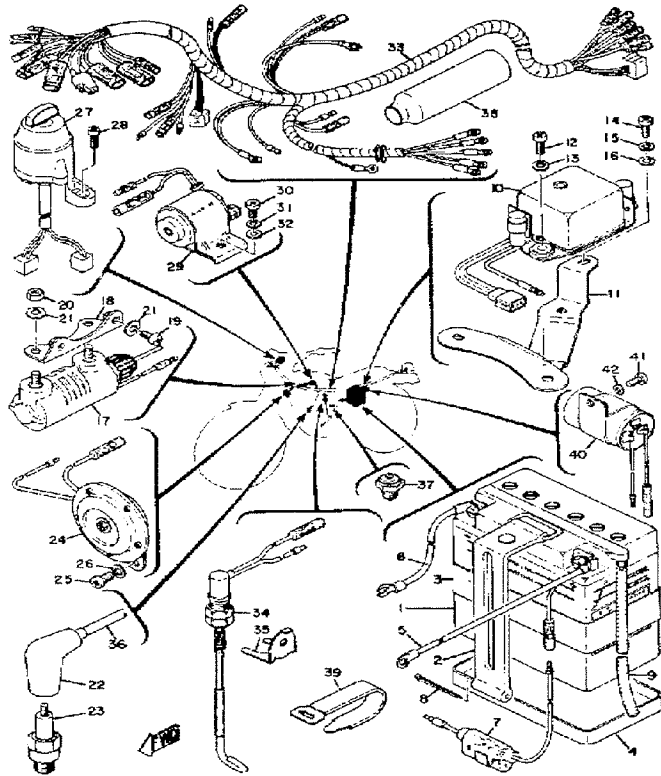

(AT3)

ELECTRICAL - CHARGING SYSTEM (MFR) (TYPE)	Hitachi Starter-Dynamo
NO LOAD VOLTAGE ADJUSTMENT	15.8-16.5/2500 RPM
MAXIMUM OUTPUT (W)	14V 7A @ 2300 RPM
FIELD COIL (and/or) CHARGING COIL RESISTANCE	4.8Ω @ 20°C
BATTERY (MFR) (MODEL) (RATING)	Furukawa 22N7-3B 12V /AH
HEADLIGHT/TAILLIGHT RATINGS	12V25/25W 12V7/27W
IGNITION COIL SPARK GAP (MIN)/PRI. RES./SEC. RES.	6mm 4.0Ω 11KΩ
CONDENSER CAPACITY	0.22μF
POINT GAP (NOMINAL)/SPARK PLUG (TYPE) (GAP)	.30-.40mm/NGK B-8ES 5-.6mm/.020"-.023"
TIMING	1.8 ± .15mm BTDC at full advance

Ref. No.	Part Number	Description	Qty	Remarks
1	BTY-12N73-B0-00	YUASA 12N7-3B	1	
2	261-82131-00-00	BAND, BATTERY	1	
3	1UA-82124-00-00	BAND, BATTERY	1	
4	(173-82122-00-00)	SEAT, BATTERY	1	
5	(261-82115-01-00)	WIRE, PLUS LEAD	1	
6	(261-82116-01-00)	WIRE, MINUS LEAD	1	
7	2UJ-82150-01-00	FUSE HOLDER ASSEMBLY (2UJ-82150-00-00)	1	
8	91401-40040-00	PIN, COTTER	1	
9	90445-08171-00	HOSE	1	
10	444-81910-10-00	VOLTAGE REG ASSEMBLY	1	
11	(261-81915-00-33)	PLATE, REG FITTING	1	
12	98503-06014-00	SCREW, PAN HEAD (92502-06016)	2	
13	92995-06100-00	WASHER, SPRING	2	
14	98580-05010-00	SCREW, PAN HEAD	1	
15	92990-05100-00	WASHER, SPRING	1	
16	92990-05200-00	WASHER, PLAIN	1	
17	254-82310-60-00	IGNITION COIL ASSEMBLY	1	
18	(248-82316-00-00)	BRACKET, IGN COIL	1	
19	98580-06012-00	SCREW, PAN HEAD	2	
20	95380-06600-00	NUT	2	
21	92995-06100-00	WASHER, SPRING	4	
22	56J-82370-00-00	PLUG CAP ASSEMBLY	1	
23	NGK-B8ES0-00-00	PLUG, SPARK (NGK B8ES)	1	
24	326-83371-21-00	HORN	1	
25	97013-06012-00	BOLT	2	
26	92995-06100-00	WASHER, SPRING	2	
27	(261-82508-11-00)	MAIN SWITCH ASSEMBLY	1	

CONTINUED ON NEXT FRAME ►

ELECTRICAL (AT2 - AT3)

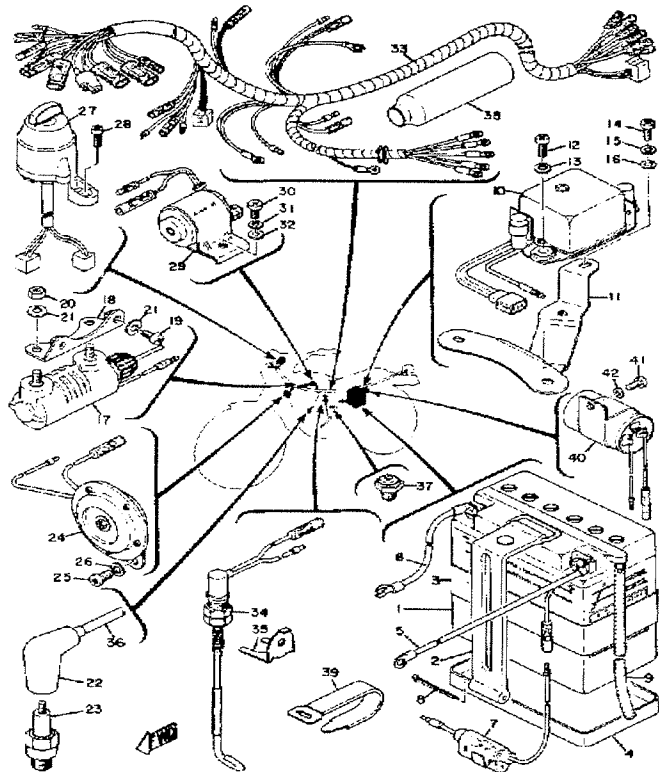

Ref. No.	Part Number	Description	Qty	Remarks
28	98701-05016-00	SCREW, FLAT HEAD	2	
29	261-81940-11-00	STARTER SWITCH ASSEMBLY	1	
30	98503-06014-00	SCREW, PAN HEAD (92502-06016)	1	
	98580-06012-00	SCREW, PAN HEAD	1	
31	92995-06100-00	WASHER, SPRING	1	
32	92990-06200-00	WASHER	1	
33	(316-82590-10-00)	WIRE HARNESS ASSEMBLY	1	
34	248-82530-02-00	STOP SWITCH ASSEMBLY	1	
35	(248-82539-00-00)	STAY, STOP SWITCH	1	
36	137-82341-01-00	CORD, HIGH TENSION 1 (3AD-82341-00-00)	1	
37	136-82540-00-00	NEUTRAL SWITCH ASSEMBLY	1	
38	(214-82599-00-00)	COVER, CONNECTER	1	
39	437-83936-01-00	BAND, SWITCH CORD	1	
40	278-83350-71-00	FLASHER RELAY ASSEMBLY	1	
41	97013-06012-00	BOLT	1	
42	92995-06100-00	WASHER, SPRING	1	
1-1	(104-82111-20-00)	CAP, BATTERY	6	
7-1	1A0-82161-00-00	. FUSE (20A) (148-82151-00-00)	2	

(AT3)

ELECTRICAL - CHARGING SYSTEM (MFR) (TYPE)	
NO LOAD VOLTAGE ADJUSTMENT	Hitachi Starter-Dynamo
MAXIMUM OUTPUT	15.8-16.5/2500 RPM
FIELD COIL (and/or) CHARGING COIL RESISTANCE	14V 7A @ 2300 RPM
BATTERY (MFR) (MODEL) (RATING)	4.80 ± 20 C
HEADLIGHT/TAILLIGHT RATINGS	Furukawa 22N7-3B 12V /4H
IGNITION COIL SPARK GAP (MIN)/PRI. RES./SEC. RES.	12V25/25W 12V7/27W
CONDENSER CAPACITY	6mm 4.0Ω 11KΩ
POINT GAP (NOMINAL) /SPARK PLUG (TYPE) (GAP)	0.22μF
TIMING	.30-.40mm/NGK B-8ES .5-.6mm/.020"-.023"
	1.8 ± .15mm BTDC at full advance

ELECTRICAL (CT2 - CT3)

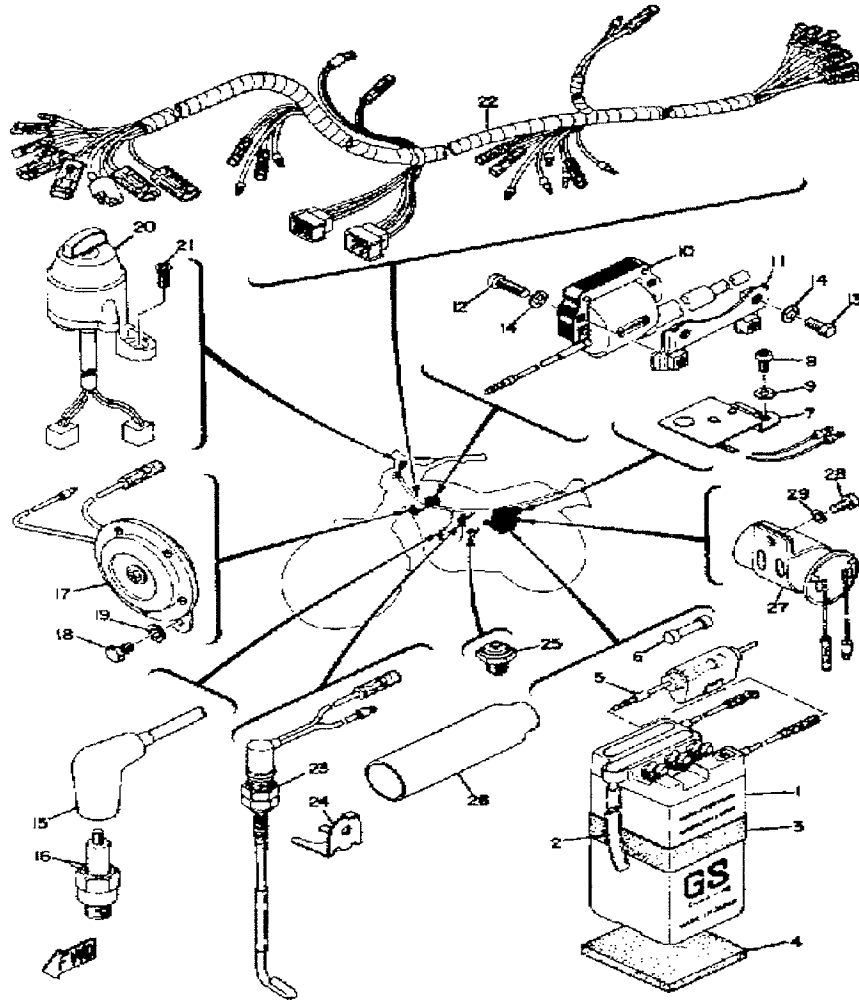

Ref. No.	Part Number	Description	Qty	Remarks
1	BTY-6N4A4-D0-00	YUASA 6N4A-4D (6N4A-4D) . . .	1	
2	(170-82112-00-00)	PIPE, BREATHER	1	
3	214-82124-00-00	BAND, BATTERY	1	
4	583-24182-00-00	DAMPER, LOCATING 2	1	
5	55K-82150-01-00	FUSE HOLDER ASS"Y (55K-82150-00-00)	1	
6	116-82151-00-00	. FUSE (10A)	2	
7	315-81970-61-00	RECTIFIER ASSEMBLY	1	
8	98580-05010-00	SCREW, PAN HEAD	1	
9	92990-05100-00	WASHER, SPRING	1	
10	304-82310-30-00	IGNITION COIL ASS"Y	1	
11	(315-82316-00-00)	BRACKET, IGN COIL	1	
12	98511-06025-00	SCREW PAN HEAD (92501-06025)	2	
13	97013-06012-00	BOLT	2	
14	92995-06100-00	WASHER, SPRING	4	
15	56J-82370-00-00	PLUG CAP ASSEMBLY	1	
16	NGK-B8ES0-00-00	PLUG, SPARK (NGK B8ES) . . .	1	
17	266-83371-12-00	HORN	1	
18	97013-06012-00	BOLT	2	
19	92995-06100-00	WASHER, SPRING	2	
20	251-82508-21-00	MAIN SWITCH ASSEMBLY . . .	1	
21	98701-05016-00	SCREW, FLAT HEAD	2	
22	(314-82590-20-00)	WIRE HARNESS ASSEMBLY . .	1	
23	248-82530-02-00	STOP SWITCH ASSEMBLY . . .	1	
24	(248-82539-00-00)	STAY, STOP SWITCH	1	
25	136-82540-00-00	NEUTRAL SWITCH ASSEMBLY	1	
26	(214-82599-00-00)	COVER, CONNECTER	1	
27	(115-83350-62-00)	FLASHER RELAY ASSEMBLY . .	1	

CONTINUED ON NEXT FRAME ►

ELECTRICAL (CT2 - CT3)

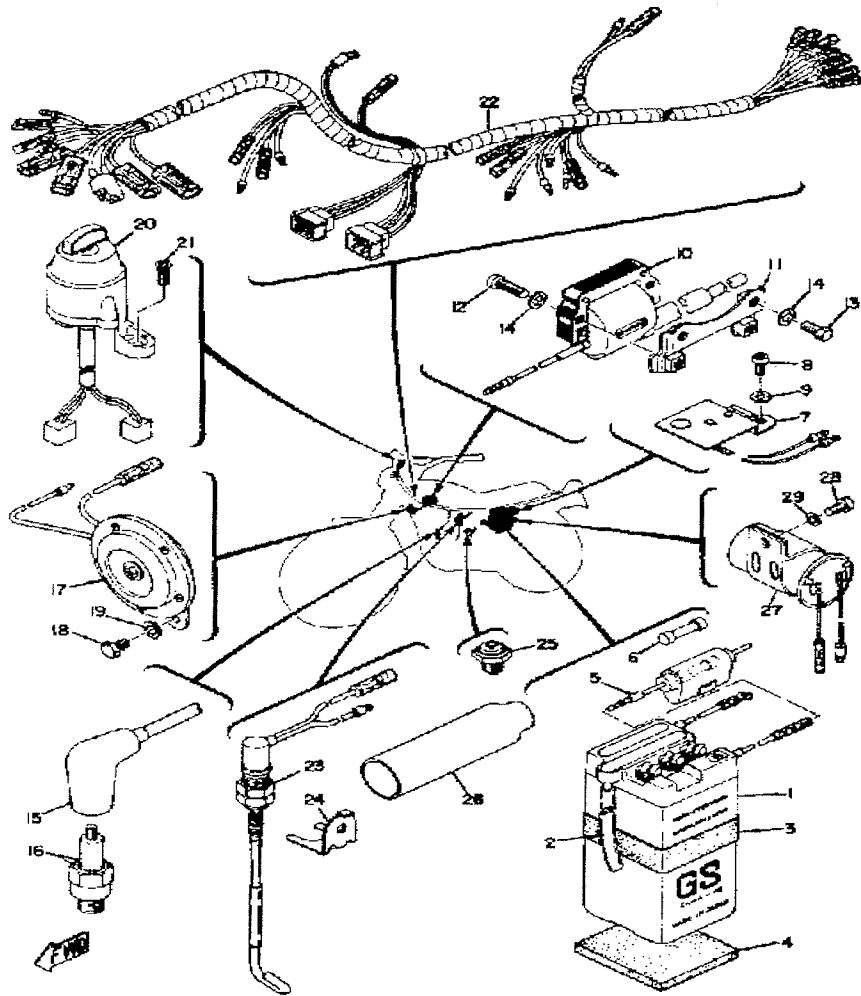

Ref. No.	Part Number	Description	Qty	Remarks
28	97013-06012-00	BOLT	1	
29	92995-06100-00	WASHER, SPRING	1	
1-1	(104-82111-10-00)	CAP, BATTERY	3	